

## REP-REP-RAE9051-5141000 REP-REP-RAE9051-5141000 - Removing and installing left or right front door trim panel - V.1, VIN: XXXXXXXX

---

ISTA system version	4.19.40.18949	Data version	R4.19.40	Programming data	-
VIN	XXXXXXXX	Vehicle	3'/E91/Sports Wagon/325i/N53/MANUAL/ECE/LL/2010/12		
Int.lev.works	-	Int.lev. (cur.)	-	Int.lev.(tar.)	-
Mileage	-				

---

51 41 000

Removing and installing  
left or right front door trim  
panel



### Special tools required:

- [00 9 317](#)



### Necessary preliminary tasks:

#### Driver's side only:

- Remove [decorative strip from door trim panel](#)

#### Passenger side only:

- Remove [cover on door handle](#)

#### Driver's side only:

Release screws (1).

Tightening torque [51 41 1AZ](#).

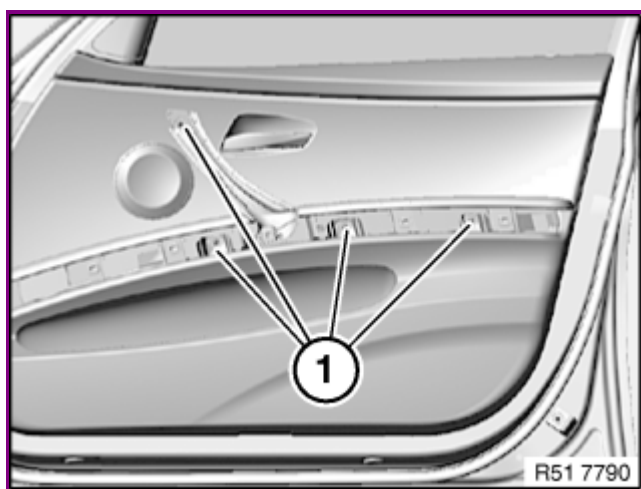
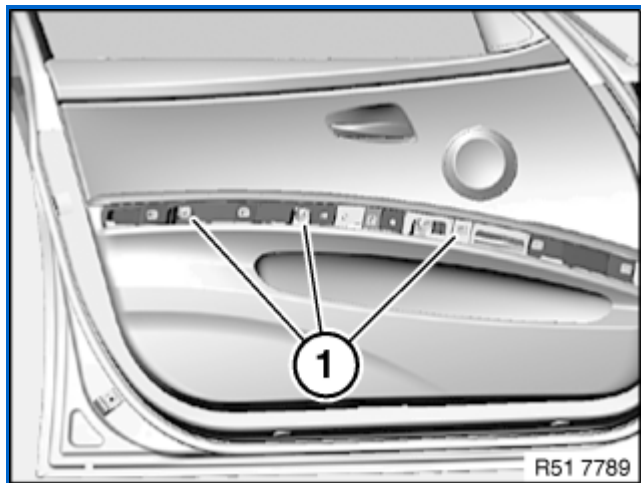

Passenger side only:

Release screws (1).

Tightening torque [51 41 1AZ](#).

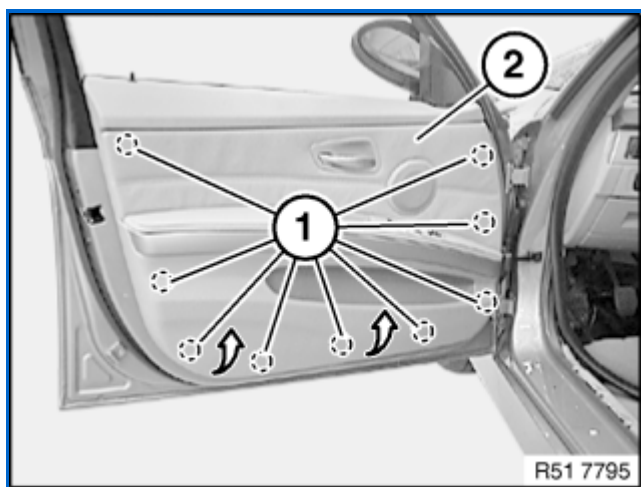

*Note:*

Start by unclipping door trim panel (2) at bottom.

Unclip clips (1) for door trim panel (2) with special tool [00 9 317](#).

Carefully unclip door trim panel (1) at top from retainers (2).

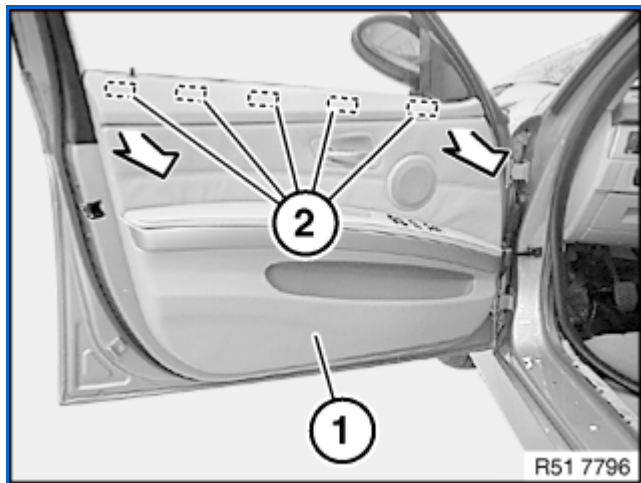

Unhook Bowden cable (1) from door lock (2).

Disconnect all plug connections and remove door trim panel.

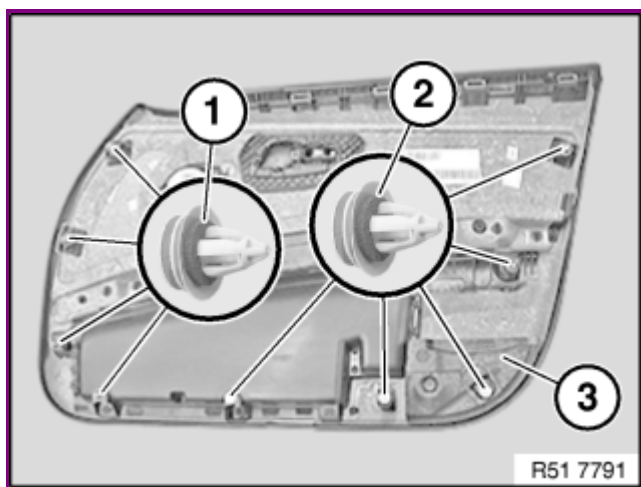
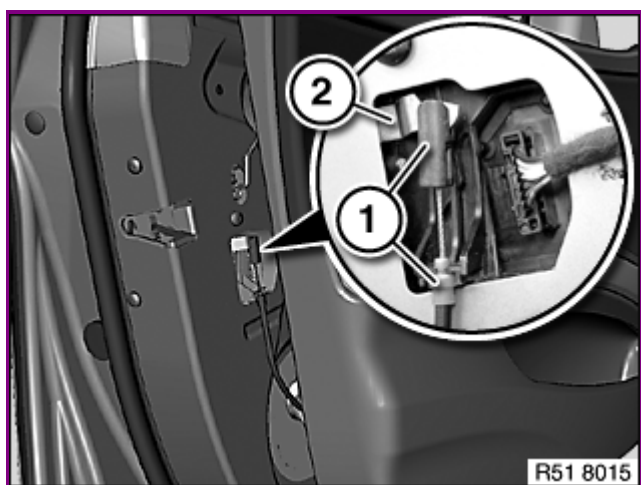

*Installation:*

If necessary, replace faulty clips.

Fit all clips with sealing ring.

Make sure clips are installed in correct position.

1 Grey clip

2 White clip

US/CND version:

Crashpad (3) must be correctly fitted.

[\(see Replacing door trim panel\)](#)



*Installation:*

After assembling the door trim panel proceed as follows:

- Open door window.
- Lock with vehicle key.
- Check for ease-of-movement on retaining button linkage
- If necessary, align linkages