

**Characteristics:**

High Power High Voltage DC Motors

**Specifications:**

Dimensions	: Ø 52.4 X 84.7 mm
Shaft Diameter	: Ø 6.351 mm
Input Voltage	: 120.0 V DC
Rectified	: Rectified
No Load Speed	: 10843 rpm
Maximum Efficiency	: 72%
Torque at Maximum Efficiency	: 183.20 mNm
Speed at Maximum Efficiency	: 8261 rpm
Weight	: 618 g
Operating Temperature Range	: -10 to 55 °C
Storage Temperature Range	: -20 to 80 °C
Electrcial Connection	: Terminal

**Performance Data:**

	No Load	Stall	Maximum Efficiency	Maximum Power
Current (A)	1.08	-	3.45	-
Efficiency (%)	-	-	72	-
Output Power (W)	-	-	157.81	-
Speed (rpm)	10843	-	8261	-
Torque (mNm)	-	-	183.20	-

**Application Examples:**

Grinders, Coffee Machines

Outline Drawing:

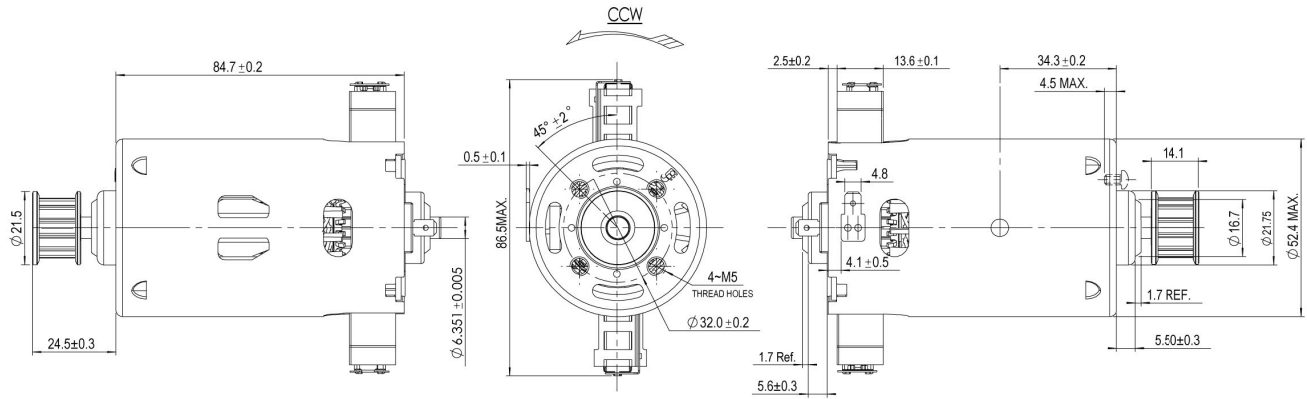

Performance Curves:

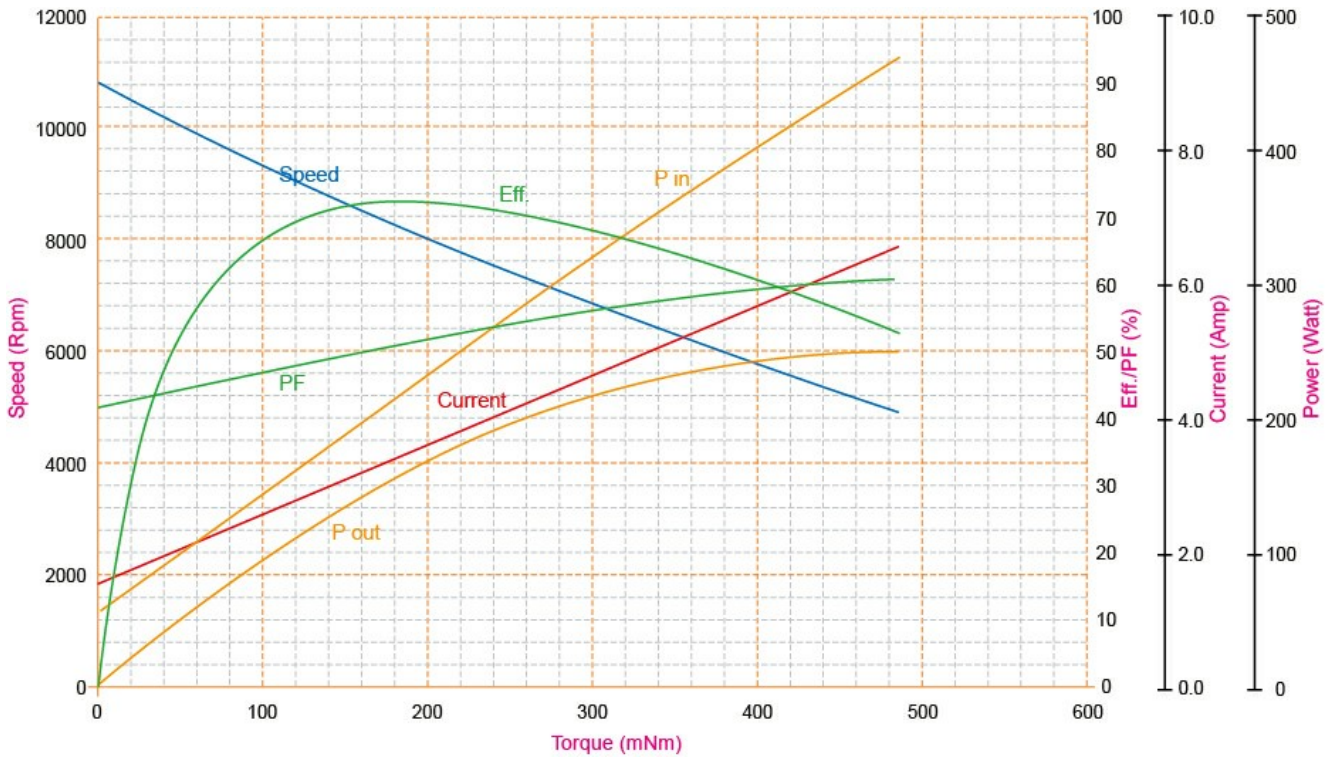

Units in Metric