

HOW McLAREN-HONDA
FAILED ON COMEBACK

THE SECRETS OF
FERRARI'S REVIVAL

LEWIS GETS YOUR
VOTE AT AWARDS



AUTOSPORT

F1 2015 Review



haymarket
9 770269 946265
50
Dec 10 2015
UK £3.70
CAN \$8.99

New look • More analysis • In-depth features



SCOTT SPEED
GRC

NELSON PIQUET
FORMULA E

PORSCHE
24HR LE MANS & WEC

TIM GAJSER
MX2

CLINTON MOORE
RED BULL X-FIGHTERS

MARC COMA
RALLY

ROMAIN FEBVRE
MXGP



TONI BOU
TRIALS

NASSER AL ATTIAH
DAKAR RALLY

DANNY KENT
MOTO3

JONATHAN REA
WORLD SUPERBIK

JOHN McGUINNESS
SENIOR TT & ZERO TT

KYLE BUSCH
NASCAR

JORGE LORENZO
MOTOGP



**ALPINESTARS PROTECTS
CHAMPIONS**
ALPINESTARS.COM

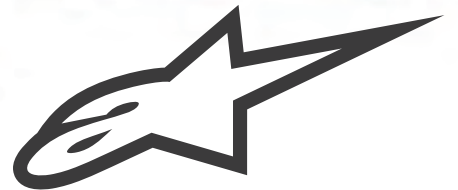

WE ARE ALL RACERS



THE HIGH PERFORMANCE TYRE FOR RACERS.

**MICHELIN PILOT SPORT CUP 2,
Approved for the PORSCHE Cayman GT4.**

When it comes to high performance, Porsche and Michelin share the same passion for perfection. So when the uncompromising Cayman GT4 needed a new level of contact with the ground, Porsche and Michelin worked shoulder

to shoulder to craft, test and finally codevelop a truly exceptional high performance tyre. It's simply the latest chapter in more than fifty years the pair have spent together pursuing excellence on the road and in motorsport. No wonder that Michelin has been selected by Porsche as its strategic partner for tyres.



MICHELIN Pilot Sport Cup 2 the track tyre suitable for everyday use. Thanks to MICHELIN Total Performance you can enjoy high performance and optimal safety together in total confidence.



Release your inner racer and discover the MICHELIN high performance tyre range at:
www.michelin.co.uk





Our readers make the Awards what they are

SUNDAY NIGHT'S AUTOSPORT AWARDS IS ALWAYS A great occasion, even if we do say so ourselves! It's made by the fact that so many great names of the past, present and future of this fantastic sport are there – and all the more special because the awards recognising achievement during the year are voted for by you, the readers of *Autosport*.

Inevitably, there were some gripes about the winners. We make no excuses that Lewis Hamilton won the International Racing Driver of the Year and British Competition Driver categories – not just because it was a result of your votes, but because winning a third world championship is a hell of an achievement no matter who you are. Inevitably, F1 drivers always do well in these awards because the interest level is so high, but it's important to note that across the three categories Hamilton and Mercedes won, plus the rookie of the year prize (won by Max Verstappen), only 46 per cent of the nominees came from grand prix racing.

One of the great appeals of motorsport is that it is such a broad church. It is frustrating that the overall interest levels in categories outside F1 is not as high as it should be, but the public voting reflects the fact that it remains the flagship for the sport for most.

That's one of the reasons why Nico Hulkenberg received a Gregor Grant Award for winning Le Mans. His desire to compete in the greatest race on the planet alongside his F1 commitments stirred up enormous interest in the race among those in the fanbase who previously ignored it, as well as encouraging some of his F1 rivals to look at racing there one day.



EDD STRAW EDITOR

edd.straw@haymarket.com

@eddstrawF1



COVER IMAGE

XPB Images; Coates, Dunbar, Etherington and Staley/LAT

F1 SEASON REVIEW

- 6** Hamilton's greatest year
- 16** Top 10 drivers of 2015
- 23** Team bosses' top 10
- 25** News review of the year
- 34** Team by team: Mercedes
- 36** Great car: Mercedes F1 W06 Hybrid
- 38** Team by team: Ferrari
- 40** Vettel's Ferrari breakthrough
- 44** Team by team: Williams, Red Bull
- 48** Renault's nightmare season
- 52** Team by team: Force India, Lotus, Toro Rosso, Sauber, McLaren
- 58** Honda's disastrous return
- 62** Team by team: Manor
- 67** Dieter Rencken's political review
- 70** The grands prix rated
- 72** Season statistics

PIT+PADDOCK

- 74** McLaren's F1 concept car

AUTOSPORT AWARDS

- 80** *Autosport* Williams Engineer of the Future
- 82** All the winners from our big bash

RACE CENTRE

- 104** V8 Supercars, Andros Trophy

CLUB AUTOSPORT

- 115** F4 drivers head to GT racing
- 116** Super Touring to Knockhill
- 121** Humble Pye







FINISHING STRAIGHT

- 122** What's on
- 124** From the archive
- 126** Top five Draco drivers

AUTOSPORT SUBSCRIPTION OFFER

- 120** Sign up and get a FREE Merc thermo mug

FIND US ON

-  autosport.com
-  twitter.com/autosport
-  facebook.com/autosport
-  instagram.com/autosportdotcom/
-  youtube.com/AUTOSPORTdotcom
-  at the Apple App Store
-  digitalmagazine.autosport.com
-  Apple News

THE YEAR LEWIS HAMILTON CAME OF AGE





ILTON E

Mercedes dominated, but don't let negativity about F1 overshadow your appreciation of just how good the now-triple world champion has been this year

By Ben Anderson, Grand Prix Editor

 @BenAndersonAuto



AS REMATCHES GO, THIS ONE WILL NOT GO DOWN AS A CLASSIC. THE

'Thrilla in Manila' it certainly was not... This latest instalment of the emerging rivalry between Mercedes team-mates Lewis Hamilton and Nico Rosberg had the potential to excite Formula 1 audiences, but sadly this was a rather tame affair for the most part. Hamilton won it comfortably, not quite by knockout, but certainly by a clear and definitive points decision, and by the time things really got spicy there was nothing really to play for except pride.

Mercedes has emphatically dominated F1 since the category replaced normally aspirated V8 engines with V6 hybrid-turbo power units in 2014, and that continued this year. The dominance of a single team and technical package over the rest is nothing new, but in circumstances where only one car has a realistic chance of winning the world championship you really need the two drivers of that car to engage in an epic struggle to maintain spectator interest, beyond the come-what-may hardcore.

Last year we got a real contest. One driver was generally quicker in qualifying, the other in the races, and both had to overcome technical misfortune and adversity at different points in the season. There was also plenty of personal needle and controversy as the battle built to a climax at the final round.

Unfortunately, this season's title fight never really sparked into life. Genuine outside opposition was unforthcoming, as Red Bull and Williams both slipped back, Ferrari improved substantially but not enough to become a genuine contender (yet), while the much-vaunted return of the McLaren-Honda partnership failed to live up to (unrealistic) expectations.

Therefore it was down to last season's vanquished contender Rosberg to step up and carry the fight to his double world champion team-mate again. Eventually Rosberg rose to the occasion, but by the time he did so the championship was out of reach. Hamilton sailed off to collect his third title quite comfortably in the end, while Rosberg missed the boat.

Rosberg headed into this season believing it would only take a few small adjustments to his craft to lift the crown, after leading the standings for a large part of last year. Having bested Hamilton comfortably in qualifying in 2014 (he outqualified Hamilton 12 times in 19 races and scored 11 pole positions), Rosberg naturally felt he had that part of the competitive equation covered.

But too often he'd found himself outfoxed by Hamilton in the races. Rosberg won only five times in 2014, and only four of those victories came from pole position. Yes, the car let him down twice, but there were also plenty of occasions when Hamilton was simply too fast, found a way past, or otherwise harried Rosberg into a costly mistake. Rosberg therefore sensibly chose to focus his winter energy on finding more consistency in

“ROSBERG ROSE TO THE OCCASION, BUT BY THEN THE TITLE WAS OUT OF REACH”





the races, to lessen the chances of relinquishing those winning positions he'd worked so hard to construct.

Rosberg was actually fairly successful in his quest. Only once was he truly trounced by Hamilton during a race where Sebastian Vettel hadn't forced his Ferrari between the two Mercedes early on. That came in Monaco, where Hamilton was almost 20 seconds up the road before Mercedes made an ill-advised call to pit for tyres under a late-race safety car, handing victory to Rosberg.

Otherwise, the races were usually settled by a handful of seconds. The trouble for Rosberg was repeatedly falling the wrong side of those margins over the first two thirds of the season, the result of habitually qualifying behind his team-mate.

Only once (in May's Spanish GP, which he won) over the first 13 events did Rosberg start ahead of Hamilton on the grid. His race pace was stronger than in 2014, but this was not enough to overturn the advantage Hamilton enjoyed from running first on the road. Hamilton beat Rosberg in nine of those first 12 grands prix, winning seven of them, and but for that unfortunate Monaco reversal he would have been even further ahead. >>

His 2015 ended well, but Rosberg spent a lot of it frustrated and angry at his team-mate. Hamilton, meanwhile, was pretty pleased most of the time, his third title being well deserved amid the dominance of his Mercedes



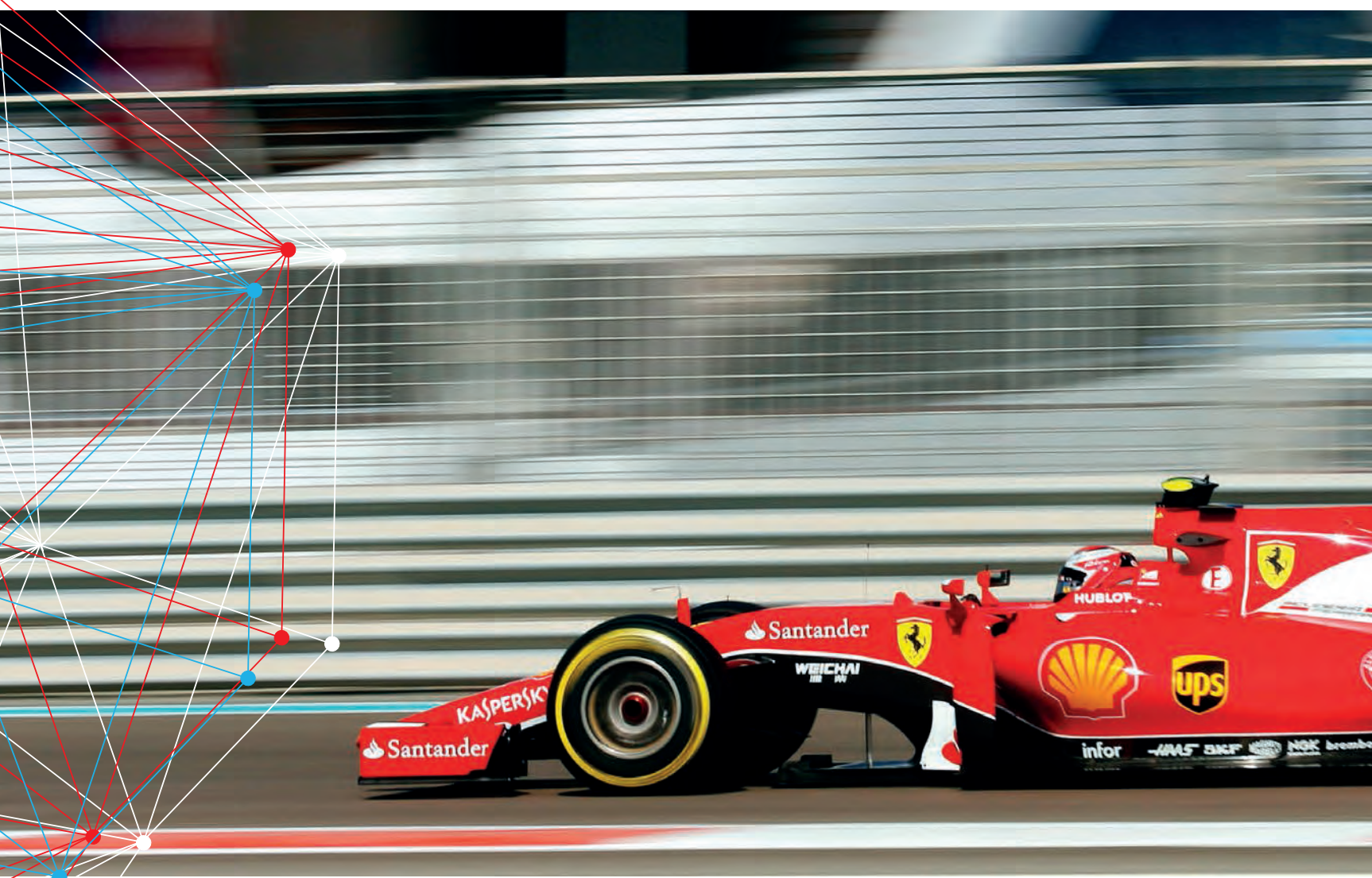

Parc ferme rules after qualifying mean F1 is always a compromise these days. Rosberg spoke of adjusting his approach to setting the car up this year, generally trying to dial the balance more towards understeer to protect the rear tyres over race distances, sacrificing single-lap pace but allowing him to be more consistent on Sundays.

But whatever tweaks he made came at too heavy a price on Saturdays. This was because Hamilton also got better this year, particularly in qualifying, which he admits was a weakness in 2014. Certainly most people would have expected the driver Jenson Button reckons is the fastest on the grid over a single lap to have started on pole more than seven times last year, in comfortably the best car in the field...

Hamilton made some adjustments of his own. Of course he wouldn't reveal what they were, but you get a sense that he drove much more within himself, building up speed more gradually and methodically through each race weekend, than he did last year. The fact that his car was generally more reliable undoubtedly helped, but the major errors that were costly in 2014 (going off twice in Austria; backing off on an improving track at Silverstone) were also eradicated – or at least the impact minimised. The result was a devastating return of 11 poles in 13 attempts.

Rosberg started on pole just once in that time, which was the key aspect of his early defeat in the title race. Rosberg likes to suggest that the difference between himself and Hamilton is all about small margins, but in actual fact that was only really the case at Shanghai, Silverstone and Singapore, where in each case Rosberg qualified within 0.130 per cent of Hamilton.

Otherwise, the deficit was substantially larger. The balance of power shifted after Singapore, Rosberg taking pole for the final six races in succession, but by then Hamilton had done so much

damage it was almost impossible for Rosberg to recover.

Of the seven pole positions Rosberg secured this year, only four (Spain, Russia, Mexico and Abu Dhabi) were secured by a margin of more than 0.2 per cent. The rest of the time Hamilton lapped within 0.11 per cent of his team-mate.

Rosberg was 0.157 per cent slower than Hamilton on average in qualifying this year, across 18 races (Monza is disregarded on account of the two drivers using different engine specifications after Rosberg's new unit was contaminated in practice). Last year, Rosberg was 0.164 per cent *faster* than Hamilton across the balance of the season (disregarding Germany and Hungary on account of technical problems for Hamilton).

That seems like a massive swing from one season to the next, but if you take out two massive outliers in the 2014 data – China (Rosberg spun on his final Q3 attempt, favouring Hamilton) and Silverstone (Hamilton bizarrely aborted his in the rain, favouring Rosberg) – the gap was only 0.019 per cent in favour of Rosberg.

So although Hamilton appeared to get trounced by Rosberg in qualifying across the balance of 2014, in actual fact he only needed to find a small amount of extra performance to put himself in the ascendant. This is probably why Hamilton was able to improve in qualifying this year *without* sacrificing too much race speed.

Shorn of the burden of expectation that weighed him down from his maiden championship success in 2008 until he finally made it a double in 2014, Hamilton was relentless as he stormed to title number three with three races to spare. He was superb, and Rosberg simply could not find an answer.

The competitive momentum shifted a little after Singapore, where Mercedes encountered a tyre-warm-up disaster with the W06 and both cars failed to qualify in the top four (the only time

“FERRARI HAD MADE MASSIVE GAINS OVER THE WINTER”



STALE/LAT



TEE/LAT

that happened all season). After this race, Rosberg rediscovered some of his old magic, taking pole for each of the last six races.

He was not able or prepared to fully explain this shift, but Hamilton suggested something had changed on the car after that race in Marina Bay that maybe favoured his team-mate. Certainly the car evolved after this race (as they always do), and it's true that aerodynamic and mechanical modifications were made to prevent a repeat of the tyre difficulties Mercedes suffered.

Perhaps these favoured Rosberg inherently, perhaps Rosberg was just better at exploiting the late-season iteration of the W06 than Hamilton. Whatever, Hamilton had already done the bulk of his >>

Vettel wasted no time settling in at Ferrari, and has been strong in his first year. Overjoyed Hamilton took his third title in America, and became the first Briton to claim back-to-back titles



TEE/LAT



Race by race

AUSTRALIA

1 Hamilton 2 Rosberg 3 Vettel

Hamilton begins world title defence with a commanding victory. Vettel starts life at Ferrari with a podium in third. Bottas does not make the start after being ruled out with a back injury sustained in qualifying. Neither Manor runs all weekend as the team fights to get back into F1.

MALAYSIA

1 Vettel 2 Hamilton 3 Rosberg

Vettel ends his and Ferrari's win droughts as he beats Hamilton to victory with a superior race strategy in hot conditions. Hamilton and Rosberg complete the podium. Raikkonen recovers from a first-lap puncture, which drops him to the back, to finish fourth. Bottas makes a brilliant pass on Massa for fifth.

CHINA

1 Hamilton 2 Rosberg 3 Vettel

Mercedes reasserts its authority on F1 as Hamilton takes a comfortable victory. Rosberg finishes second, not mounting a serious challenge. Vettel is third, holding off a late charge from team-mate Raikkonen. Massa and Bottas have a lonely race, finishing fifth and sixth.

BAHRAIN

1 Hamilton 2 Raikkonen 3 Rosberg

Hamilton makes it three wins from four races with another dominant drive. There's a thrilling battle for the trio of places behind him, with Raikkonen coming out on top for his first podium of the year. Vettel has a messy race, making three unforced errors, to finish fifth behind a strong Bottas.

SPAIN

1 Rosberg 2 Hamilton 3 Vettel

Rosberg turns the tables on Hamilton, dominating the race weekend and converting pole into victory. Hamilton loses second to Vettel at the start but regains the place at the final round of pitstops. Bottas holds off Raikkonen to take fourth, with Massa sixth. Sainz bangs wheels with Kvyat.

MONACO

1 Rosberg 2 Vettel 3 Hamilton

Hamilton is on course to take an easy victory before Mercedes makes a blunder by pitting him when the safety car is called into action with a handful of laps to go. He rejoins behind Rosberg and Vettel, who choose not to stop, and is unable to find a way back past.

CANADA

1 Hamilton 2 Rosberg 3 Bottas

Hamilton cuts Rosberg off at the start to retain the lead from pole. The battle fizzles out with Hamilton managing fuel and Rosberg brakes before Hamilton wins. Bottas takes his first podium of the season, inheriting third when Raikkonen spins at the hairpin. Vettel is fifth from 18th on the grid.

AUSTRIA

1 Rosberg 2 Hamilton 3 Massa

Rosberg dives down the inside of polesitter Hamilton at Turn 1 to take the lead and controls the race from the front to secure victory. Hamilton settles for second ahead of Massa, who scores his first podium of the season after Vettel is delayed in the pits.

BRITAIN

1 Hamilton 2 Rosberg 3 Vettel

Hamilton wins a thrilling rain-hit race, which is initially led by Williams. Polesitter Hamilton drops behind Massa and Bottas at the start, before clawing his way back and excelling in the wet conditions. Both Williams cars suffer in the rain and end up fourth and fifth behind a resurgent Vettel.

HUNGARY

1 Vettel 2 Kvyat 3 Ricciardo

Mercedes fails to finish on the podium for the first time in 29 races as Vettel wins a frantic race. Kvyat scores the first podium of his career with second while team-mate Ricciardo loses his chance of a win through clashes with Hamilton and Rosberg. Verstappen drives superbly to finish fourth.

BELGIUM

1 Hamilton 2 Rosberg 3 Grosjean

Hamilton gets back to winning ways with Rosberg second. Vettel is on his way to third until a spectacular tyre failure ends his race. Grosjean capitalises to score a Lotus shock podium. Renault woe for Ricciardo sees a podium chance disappear. Perez scores fifth for Force India.

ITALY

1 Hamilton 2 Vettel 3 Massa

Hamilton wins and extends his championship lead when Rosberg retires late on with engine failure. Hamilton told to push late on, as team fears penalty for tyre-pressure irregularity. Vettel finishes 25 seconds adrift in second. Raikkonen drops from second to last at the start but finishes fifth.

SINGAPORE

1 Vettel 2 Ricciardo 3 Raikkonen

Vettel wins from pole position as Hamilton retires for the first time this season with an engine problem. Rosberg fails to capitalise and finishes fourth, behind Ricciardo and Raikkonen. Safety car needed when a fan randomly wanders along the track.

JAPAN

1 Hamilton 2 Rosberg 3 Vettel

Normal service is resumed as Mercedes dominates to secure a one-two. Hamilton gives Rosberg the squeeze at the start and remains in control to take victory. Verstappen scores points, having started 17th, while Alonso likens his Honda power unit to a GP2 engine, crossing the line 11th.

RUSSIA

1 Hamilton 2 Vettel 3 Perez

Rosberg fends off Hamilton at the start but later retires with a throttle issue. Raikkonen and Bottas collide, with the Williams ending up in the barriers. Perez snatches impressive third after a long stint on the softs. Raikkonen is penalised and the points swing means Mercedes wins constructors' title.

USA

1 Hamilton 2 Rosberg 3 Vettel

Hamilton bullishly forces Rosberg wide at the start to retain the lead. Ricciardo briefly leads in damp conditions. Rosberg takes P1 after switch to slicks but is caught out by a gust of wind and runs off. That gifts the win and title to Hamilton. Verstappen takes impressive fourth.

MEXICO

1 Rosberg 2 Hamilton 3 Bottas

Rosberg takes his first win since June, dominating the race from pole position. Vettel has a shocker, colliding with Ricciardo, spinning and then crashing out. Raikkonen and Bottas clash for second time in three races, but this time Raikkonen comes off worse. Perez takes sixth in front of his home fans.

BRAZIL

1 Rosberg 2 Hamilton 3 Vettel

Rosberg comes across Hamilton at the start, defending boldly. Hamilton shadows him on a three-stopper and ultimately has to settle for second. Bottas's fourth secures third in the constructors for Williams. But Massa (fifth) excluded for a tyre-pressure irregularity.

ABU DHABI

1 Rosberg 2 Hamilton 3 Raikkonen

Rosberg ends the season by taking sixth successive pole position and converting it into his third straight win. Hamilton is allowed to choose his own strategy but it's not enough to seriously challenge Rosberg. Raikkonen takes third podium of the year while Vettel recovers from 15th on the grid to fourth.



“ONCE ROSBERG GOT ANGRY HE BEGAN TO DRIVE BRILLIANTLY”

work and, after clinching victory number eight of the season next time out in Japan, only needed podium finishes from each of the remaining races to guarantee the title.

When Rosberg lost a likely victory to a throttle-pedal-damper failure in Russia, Hamilton was almost completely off the hook and Rosberg actually slipped behind Vettel's Ferrari in the standings.

It was around this point that the personal battle between the Mercedes drivers finally got interesting. At the previous race at Suzuka Hamilton had qualified second to Rosberg, but felt he would have been on pole but for Daniil Kvyat crashing his Red Bull spectacularly and causing an early halt to the session.

Hamilton made a better start than Rosberg, and challenged for the lead on the inside as they plunged into Turn 1. Rosberg attempted to come back at Hamilton on the outside as the two Mercedes entered the uphill right of Turn 2, but Hamilton maintained momentum on the inside, completing his pass and also hanging Rosberg out to dry over the exit kerb.

Rosberg showed strong race pace thereafter, but had to fight his way back into second place after dropping down the order, by which time Hamilton was up the road and gone.

After his Sochi disaster, Rosberg headed to Austin's US GP with his title hopes hanging by a thin thread. He qualified on pole again, but made a slow start in slippery conditions. Hamilton surged alongside as they sped up the hill towards the first left-hander. Hamilton again pulled off a pass, but the two silver cars collided at the apex, which again forced Rosberg off the circuit and cost him several positions.

He recovered superbly (successfully sticking a passing move on Hamilton in the process) and led the race heading into the final few laps, only to make a mistake and run off track briefly. This error gifted victory to his team-mate, and with it enough points to clinch a historic third world title, allowing Hamilton to achieve his life's ambition of matching his hero Ayrton Senna's championship tally.

Rosberg was furious afterwards – that his mistake had gifted Hamilton victory, that he had lost any hope of denying his team-mate the championship, and that (in his mind) Hamilton had again got away with driving him off the road.

This tension had been bubbling under the surface for some time. It all began in Bahrain 2014, when Rosberg qualified on pole and was faster than Hamilton in the race, but simply could not make a move stick to get back into the lead.

Every time Rosberg tried, Hamilton found a way to strike straight back and reclaim the advantage. There was one moment in particular, where they came out of Turn 4 together and headed into the fast chicane of 5/6 side by side, in which Hamilton forced Rosberg to either back out or risk collision. Rosberg backed out, and from then on Hamilton has held the psychological edge in combat.

Spa 2014, where Mercedes severely reprimanded Rosberg for driving into Hamilton at Les Combes on the first lap, further deepened this distinction. Rosberg was desperate to prove he was no pushover in wheel-to-wheel battle, but ended up damaging two cars, and his own relationship with the team.

It is in this context we must place the incidents at Suzuka and Austin this season, where Rosberg and Hamilton again went wheel to wheel, and each time Hamilton aggressively forced his team-mate to back out or risk a collision. In America they had that collision, and it was psychologically important for Rosberg that they did, to prove that he can fight wheel to wheel with Hamilton.

But that will never sit easily with the corporate image of your employer... Mercedes held separate meetings with its two drivers ahead of the next race in Mexico, to reiterate the rules of engagement. Essentially, 'you are allowed to race each other hard, but not drive into each other'. By now, relations between the pair had plunged to sub-zero levels.

They each refused to reveal details of the discussions, but now began sniping at the other in public. Hamilton suggested Mercedes was pandering to Rosberg, and made a point of mocking the "gust of wind" that Rosberg claimed blew him off the track while leading at Austin; Rosberg made light of Hamilton's "excuses" for being off the pace in qualifying over the final leg of the season.

This was the sort of needle missing early on; the sort of psychological warfare that is sometimes necessary to win in top-line sport (and entertain the crowds!); the sort of warfare that was present in 2014 until Rosberg drove into Hamilton at Spa and received his reprimand.

This time Rosberg felt he was the aggrieved party, and once he got angry drove brilliantly, discovering a determination and resolve that appeared to be missing before. Meanwhile, Hamilton faded into the background a little – still fast in the races, but unable to overturn Rosberg's new-found advantage. He railed against the lack of overtaking opportunities in F1, against the Mercedes team's vice-like grip on strategy and engine settings (to maintain equality between its drivers), and began making reference to those post-Singapore set-up changes.

Most likely, Hamilton's late-season dip was down to a combination of his own intensity decreasing having sealed the championship (the energy required to sustain his early form would be enormous), and Rosberg maintaining a zealous quest to get back on terms as quickly as possible, after being smacked around so heavily during the first part of the season. Whatever the ins and outs, it was too little too late for Rosberg, only proving enough to haul him clear of Vettel's Ferrari to finish runner-up in the standings for the second season in a row.

The fact that Vettel remained in title contention himself >>



Best Force India result all year was this third for Perez in Russia. McLaren had a terrible season, the best result being a fifth for Alonso

until Hamilton's victory in America is indicative of how much better both Ferrari and its new four-time world champion driver were this year, after dispiriting campaigns in 2014. The Scuderia made massive gains over the winter, allowing it to win three times and leapfrog Red Bull and Williams with what proved to be the second best car on the grid at most races, while Vettel rediscovered the form that was missing for much of last year, after finally leaving the Red Bull fold.

Red Bull performed the opportunist-underdog role last year, and came into this campaign hoping winter improvements from engine supplier Renault would allow it to challenge for a fifth crown, but

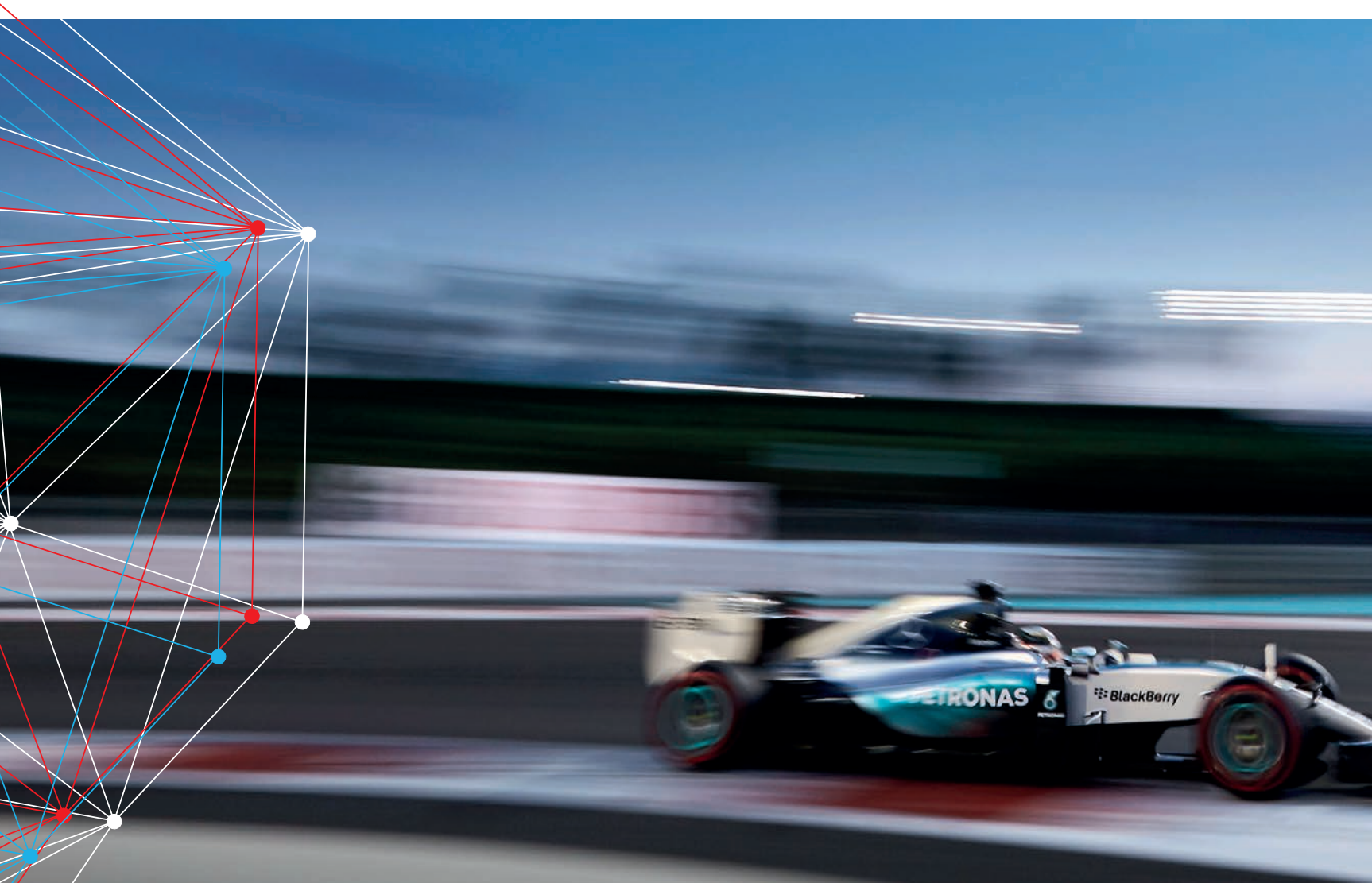

those gains did not materialise and led to a very public falling out between the manufacturer and its customer.

Progress was there but came too late, and Red Bull's poor season meant it slipped to fourth in the final reckoning, behind Williams, which challenged Mercedes several times last season on certain circuits but wasn't as relatively strong this year. Only once (for the first part of the British Grand Prix at Silverstone) did Sir Frank's team challenge for victory; the rest of the time it was fighting Ferrari (and latterly Red Bull) to be best of the rest, and only on occasion did it come out on top.

McLaren-Honda arguably should have been in this fight too, but a disastrous season meant it slipped to the back of the midfield, behind Force India, Lotus, Toro Rosso and Sauber. The woefully slow MP4-30 was a waste of the talents of world champions Fernando Alonso and Jenson Button, who put brave faces on a difficult season.

Once Force India finished introducing its major upgrade mid-year it was clearly the best of these teams, deservedly finishing fifth in the constructors' race. Toro Rosso will feel this was the season it should have topped that fight, producing a quick car that allowed rookie drivers Max Verstappen and Carlos Sainz Jr to really shine at times, but Renault unreliability proved too much to overcome in the end.

The Red Bull 'B-team' was the only one of these midfielders not to require a cash advance from Bernie Ecclestone in order to ready cars in time for the start of the campaign, again highlighting the precarious financial nature of F1's independent competitors since these V6 hybrid engines were introduced. Budgets have gone up, income rises have not matched them, and some continue to suffer.

Though none perished in the way Caterham and Marussia did at the back end of last year, there was still a concerted effort to adopt a cheaper alternative for 2017, in the face of intransigence from the current manufacturers over the price of supplying customers. Politically, this is arguably the first time the FIA and FOM have aligned since Jean Todt became president. He wants to reduce costs in F1, and Ecclestone wants to boost audiences that he feels have been driven away by Mercedes' dominance of the current engine formula.

Agreement (as ever in F1) still proves elusive, and Todt's former team Ferrari is at the centre of the storm, unwilling to bow to the power brokers' demands having invested heavily in trying to topple its manufacturer rival from the top of the tree. It didn't quite make it this year, but the red tide is coming, and all it would take for F1's title battle to become a tantalising prospect once more is for Rosberg to continue his late-season form under real pressure, and for Ferrari and Vettel to put their scarlet cat among the silver pigeons regularly.

The question is whether F1 can sustain the arms race it will take to get there, and what casualties it will suffer in the meantime. Technological marvels are all well and good, but efficiency on the track is no good if the price is financial destruction off it. Meanwhile, Formula 1 continues to lurch from one identity crisis to another, as debates rage over the future technical direction of the category.

This has (sadly) stripped some of the gloss from Mercedes' fine achievements, and Hamilton's coming of age as a driver, and champion. This was unquestionably his year, even though it wasn't a classic for Formula 1. ❄



**“THIS WAS CLEARLY
HAMILTON'S YEAR,
EVEN THOUGH IT
WASN'T A CLASSIC”**

Top F1 drivers of 2015

Lewis Hamilton won his third title in fine style, making the most of his Mercedes' performance edge, but which other drivers impressed this year?

By Ben Anderson, Grand Prix Editor

[@BenAndersonAuto](#)



10 FELIPE MASSA

Massa's career revival continues apace at Williams. The car was not as relatively competitive as last year's, but Massa still scored two podiums and came close to matching his 2014 points tally, despite the abolition of a double-score finale.

He made few mistakes and found greater consistency, particularly in qualifying, where he was better than prodigious team-mate Valtteri Bottas across the first eight races.

He also led Bottas and Ferrari's Kimi Raikkonen in a tight battle for fourth in the championship after finishing third in September's Italian Grand Prix.

Thereafter his season went off the boil a little. He scored no points in three of the next five races (through no fault of his own), but also suffered for the FW37 becoming less competitive amid a development freeze.

Nevertheless, this was still a good year for Massa, who has laid the ghosts of his latter Ferrari days firmly to rest.

9 SERGIO PEREZ

Perez came to Force India somewhat damaged by his 2013 season at McLaren. It's taken the Mexican a while to get over that disappointment, but this year he again started regularly producing the sort of performances that made him hot property in the first place.

There were flashes of brilliance early on, particularly in Monaco, as Force India made do with an updated version of last year's car, but Perez's season sprang to life at Spa, where he made

a set-up breakthrough with the 'B-spec' VJM08 introduced mid-season.

He qualified fourth in Belgium and briefly challenged for the lead, finishing fifth, before going on to be the highest-scoring driver outside the top five in the standings until the end of the season.

His unlikely podium in Russia showed maturity and discipline, but his improved qualifying form post-Hungary (6-3 versus highly rated team-mate Nico Hulkenberg) was also noticeable. Easily his best campaign since 2012.



8 ROMAIN GROSJEAN

The last two seasons have been difficult for Grosjean, who has not possessed a car good enough to underline the sublime form he showed in the latter half of 2013.

Last year's Lotus frustrated him, but he still drove well within its limitations. This year's E23 was better, so Grosjean scored more points, but the most impressive aspect of his campaign was the way he regularly qualified among the top 10, despite the team's lack of cash

and the car's lack of development.

The Franco-Swiss made Q3 12 times in 19 races this season (team-mate Pastor Maldonado only made it four times), despite skipping first practice for 13 of the 19 grands prix to make way for reserve driver Jolyon Palmer.

His surprise podium in August's Belgian Grand Prix was a stark reminder of what Grosjean's capable of when the car is right. Lotus will feel his loss keenly next year.

7 FERNANDO ALONSO

In spite of his protestations to the contrary, Alonso has driven well this season – it's just been difficult to notice, given the uncompetitiveness of McLaren-Honda.

Even in 'economy mode' Alonso almost stole into Q3 in Bahrain (in a slow car that also had a down-on-power engine), while at Silverstone he drove exceptionally well in the wet to nick a point from the faster Sauber of Marcus Ericsson.

His qualifying laps in Singapore and Japan were also mighty (they just didn't count for much), and his performances in Hungary and for much of the US GP showed the relentless consistency that make him such a formidable racer.

Honda paid good money to lure Alonso from Ferrari, and the double world champion remains one of the very best. Currently, that ability is going to waste, which is a shame for Alonso, and a shame for Formula 1 as well.



COATES/LAT



6 MAX VERSTAPPEN

Max Verstappen is not the first rookie to make a big impression in F1, but what the young Dutchman accomplished this year was seriously impressive by any standard.

As you might expect, there were some errors and a few immature moments, but he learned quickly and, by the end of the campaign, looked more like a veteran than a teenager who spent most of the year not legally old enough to drive on Europe's roads...

Verstappen's feisty racecraft was always evident, and made him exciting to watch, but as the season wore on he became formidable in qualifying too. Good rookies often show real flashes of potential, but it takes time to add the consistency and nous necessary to deliver every weekend.

Verstappen had completed one full season of single-seater racing before this one. You wouldn't have known it on this evidence.



DUNBAR/LAT

5 VALTTERI BOTTAS

Bottas was to Ferrari what Vettel was to Mercedes this season – a constant thorn in the side that simply refused to go away, however carefully it was tweezed.

He didn't always win the battles ultimately, but showed in races such as Bahrain, Spain, Canada, Japan, Russia and Mexico that he could carry the fight to the Scuderia and, if mistakes came, it was usually

the Bottas Williams that was ready and waiting to pounce.

His Saturday form across the first half of the season was unconvincing, though he refused to blame the back injury he suffered in qualifying in Melbourne that sidelined him from the first race.

This arguably cost him his chance of driving for Ferrari next year. But it was always close with team-mate Felipe Massa, and from Hungary onwards

Bottas raised his game and dominated the intra-team battle.

He almost beat the second Ferrari of fellow Finn Kimi Raikkonen (with whom he collided twice this year) to fourth in the points too, which would have been a better result than his car merited.

Raikkonen may be the most popular Finnish driver in F1 now but, for the second season running, Bottas looked the more convincing of the two. >>



4 DANIEL RICCIARDO

This was a frustrating season for Ricciardo, who came into the campaign expecting to challenge for the world championship after winning three races in 2014.

Renault's lack of progress in the power game, coupled with Red Bull's early difficulties in unlocking the full potential of the RB11, derailed that ambition, and Ricciardo's resulting frustration boiled over.

But when he got his head right, the Australian still produced some exceptional drives, most notably in Hungary, where Red Bull made

a breakthrough with the car and he fought for victory, and Singapore, where he chased winner Vettel all the way.

But there were some less-heralded performances, such as his charge from the back of the grid to eighth at Monza, and he also squeezed consistent results out of a difficult car early in the year.

The final points table doesn't reflect how well Ricciardo drove this year. Of all the drivers on the grid yet to fight for the world championship, the Australian looks the most ready. He just needs a fast enough car to prove to the world that he's made of the right stuff.

3 NICO ROSBERG

Rosberg came into 2015 ready to win the world championship after a near-miss last year, but got "blown off" (Niki Lauda's words) by Mercedes team-mate Lewis Hamilton for much of the season.

Except that's not strictly the case. Beaten too regularly, yes, but it was closer than Lauda suggests. Rosberg was stronger in race trim than he was last year, genuinely outpacing Hamilton to win in Spain and Austria, and pushing him hard everywhere else bar Monaco (where he was 19 seconds behind before Mercedes' strategic blunder snatched victory from Hamilton) in the first part of the season.

The trouble was Rosberg lost what was actually a very small advantage over Hamilton in qualifying last season in the process, starting on pole just once in the first 12 races of this year.

Then Mercedes endured a tyre warm-up disaster in Singapore. Thereafter Rosberg rediscovered his missing edge, scoring pole for all six of the remaining grands prix, and winning three of them.

In the US he finally showed his teeth in wheel-to-wheel battle, and was better than Hamilton over the last three grands prix of the year. If the season started in October, Rosberg could make a serious case to be top of this list. Unfortunately for him, it starts in March...



2 SEBASTIAN VETTEL

If there was ever any doubt that Sebastian Vettel is one of the top drivers on the current F1 grid, this season should go a long way to obliterating that uncertainty.

After an underwhelming 2014 campaign, a switch from Red Bull to Ferrari seemed to galvanise the four-time champion, allowing him to re-discover the determination, commitment and confidence that made him such an unstoppable force in the latter part of F1's V8-engined era.

Vettel felt more at home in Ferrari's V6 hybrid-engined SF15-T compared to last year's Red Bull-Renault RB10, as was apparent in the manner of his early

season qualifying performances (when he twice split the two Mercedes drivers) and in the fact that he filled his former team-mate Daniel Ricciardo's 2014 role as the opportunistic underdog, pouncing on Mercedes' mistakes to win three times in an inferior car.

Mistakes were also few and far between, with Bahrain (he went off), Mexico (he clashed with Ricciardo then crashed out) and Abu Dhabi (he messed up in qualifying) arguably the only races where his form dipped.

Otherwise Vettel was superb, putting his world champion team-mate Kimi Raikkonen firmly in the shade with consistently excellent performances.





STALEVILAT

1 LEWIS HAMILTON

Hamilton's run to a third world title was more emphatic and more convincing than his 2014 success, thanks to stronger reliability in his Mercedes car and fewer errors from Hamilton himself.

He drove with greater verve and consistency this year, unburdened by finally winning that long-awaited second championship, and boosted by a less-volatile team environment (for the most part) at Mercedes.

He has finally come of age, looking like a driver who understands himself and the sport much better, and is more comfortable with his place in the world. Such mental stability is crucial to

success in topline sport, and Hamilton's driving reflected that greater resolve.

Overtaking last year's qualifying deficit to team-mate Nico Rosberg proved crucial in the final reckoning, and taking pole for 11 of the first 12 races was Hamilton's most devastating accomplishment, allowing him to dictate terms from the front.

Last season Hamilton had to rely heavily on his racer's instincts to get out of trouble; this season he made life a lot easier for himself.

Rosberg often looked shell-shocked on Saturdays, as he watched Hamilton repeatedly pound him into dust, usually by large margins. Hamilton was two or

more tenths clear of Rosberg in nine of the first 12 qualifying sessions this year.

On the rare occasions he needed to race hard, such as in Hungary (where he uncharacteristically went off on lap one), Japan (where he bossed Rosberg at Turn 1) and the US (where he clinched the title in tricky conditions), Hamilton showed he remains one of the toughest competitors out there in wheel-to-wheel combat.

Hamilton was second best to Rosberg over the final three races, but the championship was already over by then, so that should not detract from the magnitude of his achievement, or the majesty of his earlier performances.

THE REST

Jenson Button spent most of his time near the back of the grid, but this was another season when he went up against a world champion team-mate with a fierce record and came out with his own reputation intact. McLaren reserve **Kevin Magnussen** stood in for Alonso in Australia and shaded Button until an engine problem in qualifying. His F1 career now looks over far too soon.

Daniil Kvyat made a shaky start to his Red Bull 'senior' career, crashing on his first out-lap in testing at Jerez, but he grew in stature, justifying the decision to promote him from Toro Rosso.

Rookie **Carlos Sainz Jr** rewarded Red Bull's faith in a campaign that was far better than results suggest. He was generally excellent in qualifying, and should have scored at least 20 points more than he actually did, but his Toro Rosso let him down too often.

This was a decent season from **Nico Hulkenberg**, but not as consistently good as we've come to expect. Victory in the Le Mans 24 Hours clearly boosted his confidence, but he can do better.

Felipe Nasr showed flashes of real potential in a car that mostly struggled to cling on to the midfield. When the Sauber worked well he impressed, but he needs to get on top of the brake problems that plagued him but not team-mate **Marcus Ericsson**, who scored far fewer points but gave Nasr a run for his money on occasion.

Kimi Raikkonen continued to underwhelm at Ferrari. He was unfortunate to suffer the brunt of the Scuderia's unreliability, but also made far too many mistakes.

Pastor Maldonado impressed occasionally, and also failed to finish many races through no fault of his own, but the silly errors were still too frequent, and Grosjean obliterated him in qualifying, despite usually practising less.

At Manor Marussia, **Will Stevens** impressively got the better of highly rated team-mate **Roberto Merhi** (who had a weight and height disadvantage) across the 13 races they did together, although GP2 interloper **Alexander Rossi** ran Stevens closer during a promising five-race cameo late in the year.



CALUM LOCKIE

DAVID MASON

MSA BRITISH DUNLOP ENDURANCE CHAMPIONS 2014 & 2015

Ferrari 458 Challenge GT





CONFERENCE CENTRE RACE DAY HOSPITALITY & PUBLIC TOURS

The Williams Conference Centre is home to the largest private collection of Formula One cars in the world. Housing more than 40 of the team's seminal race cars, the collection charts the team's 30+ years of motor racing history.

INFORMATION AND ONLINE BOOKING: WILLIAMSFI.COM



WILLIAMS
CONFERENCE CENTRE
DRIVE
108 FORDSHIRE
OX12 0DD

Team principals' top 10

We again asked all 10 team bosses for their top 10 drivers for our customary end-of-season poll and world champion Lewis Hamilton again topped the vote

By Ian Parkes, Chief F1 Correspondent

[@ianparkesf1](#)

THE PANEL



TOTO WOLFF
MERCEDES



MAURIZIO ARRIVABENE
FERRARI



SIR FRANK WILLIAMS
WILLIAMS



CHRISTIAN HORNER
RED BULL



VIJAY MALLYA
FORCE INDIA



FRANZ TOST
TORO ROSSO



FEDERICO GASTALDI
LOTUS



ERIC BOULLIER
MCLAREN



MONISHA KALTENBORN
SAUBER



JOHN BOOTH
MANOR

WORLD CHAMPION LEWIS HAMILTON EMERGED as the victor of *Autosport's* Formula 1 team bosses' top 10 drivers poll for 2015.

Autosport has conducted an exclusive poll of all 10 team principals, asking them for their top 10 drivers based on performances on track, over the past 19 races. The votes are kept secret, to ensure objectivity, with only the overall standings published based on F1's scoring system of 25 points for first place, down to one for 10th.

With Hamilton winning 10 grands prix this season, and claiming his third title with three races to spare, the 30-year-old collected a grand total of 229 points from a possible maximum of 250.

Hamilton was top with most team principals, ensuring he finished 49 points clear of runner-up Sebastian Vettel, whose three wins on his move to Ferrari also made him popular with the team bosses. Nico Rosberg ended up a distant third despite his strong finish to the season.



1 LEWIS HAMILTON
229PTS
▶ NO CHANGE



2 SEBASTIAN VETTEL
180 PTS
▲ UP 5



3 NICO ROSBERG
113 PTS
▲ UP 2

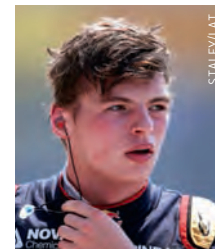

4 MAX VERSTAPPEN
77 PTS
NEW ENTRY



5 DANIIL KVIAT
69 PTS
▲ UP 5



6 FERNANDO ALONSO
57PTS
▼ DOWN 4



7 VALTTERI BOTTAS
52 PTS
▼ DOWN 3

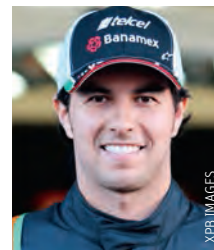

8 SERGIO PEREZ
48 PTS
RE-ENTRY



9 DANIEL RICCIARDO
47PTS
▼ DOWN 6



10 KIMI RAIKKONEN
37 PTS
RE-ENTRY

PREVIOUS SEASONS

2010

- 1 Fernando Alonso
- 2 Sebastian Vettel
- 3 Lewis Hamilton
- 4 Mark Webber
- 5 Robert Kubica
- 6 Jenson Button
- 7 Nico Rosberg
- 8 Nico Hulkenberg
- 9 Felipe Massa
- 10 Rubens Barrichello

2011

- 1 Sebastian Vettel
- 2 Jenson Button
- 3 Fernando Alonso
- 4 Lewis Hamilton
- 5 Nico Rosberg
- 6 Mark Webber
- 7 Paul di Resta
- 8 Adrian Sutil
- 9 Heikki Kovalainen
- 10 Michael Schumacher

2012

- 1 Fernando Alonso
- 2 Sebastian Vettel
- 3 Lewis Hamilton
- 4 Kimi Raikkonen
- 5 Jenson Button
- 6 Mark Webber
- 7 Nico Hulkenberg
- 8 Nico Rosberg
- 9 Sergio Perez
- 10 Felipe Massa

2013

- 1 Sebastian Vettel
- 2 Fernando Alonso
- 3 Kimi Raikkonen
- 4 Lewis Hamilton
- 5 Nico Rosberg
- 6 Romain Grosjean
- 7 Nico Hulkenberg
- 8 Mark Webber
- 9 Jenson Button
- 10 Felipe Massa

2014

- 1 Lewis Hamilton
- 2 Fernando Alonso
- 3 Daniel Ricciardo
- 4 Valtteri Bottas
- 5 Nico Rosberg
- 6 Felipe Massa
- 7 Sebastian Vettel
- 8 Jules Bianchi
- 9 Jenson Button
- 10 Daniil Kvyat



BUSINESS EXCELLENCE AWARDS 2015

IN ASSOCIATION WITH



RECOGNISING EXCELLENCE WITHIN THE MOTORSPORT INDUSTRY

Network with 500 key motorsport guests

The Awards Dinner will take place on Thursday 14th January 2016 at the NEC, Birmingham

- Networking Drinks Reception
- 3 course Dinner
- Awards Presentation
- Excellent After Dinner Entertainment from Peter Hancock

BOOK TODAY www.the-mia.com

+44 (0)2476 692 600
carly.latcham@the-mia.com



The largest stocked FHR range available anywhere!

MSA MANDATE

FHR DEVICES will be a mandatory part of safety equipment for 2016*

BE SAFE

Get your FHR Device today!
Call now for expert advice

ONLINE OFFER!
Please go online for details

*Please refer to latest MSA Mandate

www.demon-tweeks.co.uk 0844 375 2196

LOW CALL RATE CALLS MAY BE RECORDED FOR TRAINING PURPOSES MEDIA CODE: NZ252A

GRAND PRIX CHRISTMAS CARDS

Reproduced from original paintings by

Highlights of the 2015 Grand Prix season are captured in this set of five cards and envelopes, containing one each of the following subjects -

- Lewis Hamilton - Mercedes - British G.P.
- Sebastian Vettel - Ferrari - Hungarian G.P.
- Romain Grosjean - Lotus - Belgian G.P.
- Nico Hulkenberg - Force India - Austrian G.P.
- Daniel Ricciardo - Red Bull - Singapore G.P.

Card size 187 x 124mm

£6.50 per set (plus p&p) Product code **CMS-2015**

Available with or without Christmas Greeting

HOW TO ORDER

Order securely through our website, or by phone or post. We accept payment by Mastercard, Visa, Maestro/Switch or cheque (payable to Studio 88 Ltd.). Overseas payments by credit/debit card only.

POSTAL CHARGES

Orders under £15 - UK £2, Europe £5, Rest of the World £5.50
 Orders of £15 or over - UK £4.50, Europe £7.50, Rest of the World £9

Studio 88
LIMITED

P.O. Box 568, Aylesbury, Bucks. HP17 8ZX
 01296 338504

www.studio88.co.uk

Autosport.com news review of the year

If Formula 1 proves one thing, it's that a lot can happen in nine months. Here's a review of the big news stories of the season at a frantic pace

By Ian Parkes, Chief F1 Correspondent

 @ianparkesf1

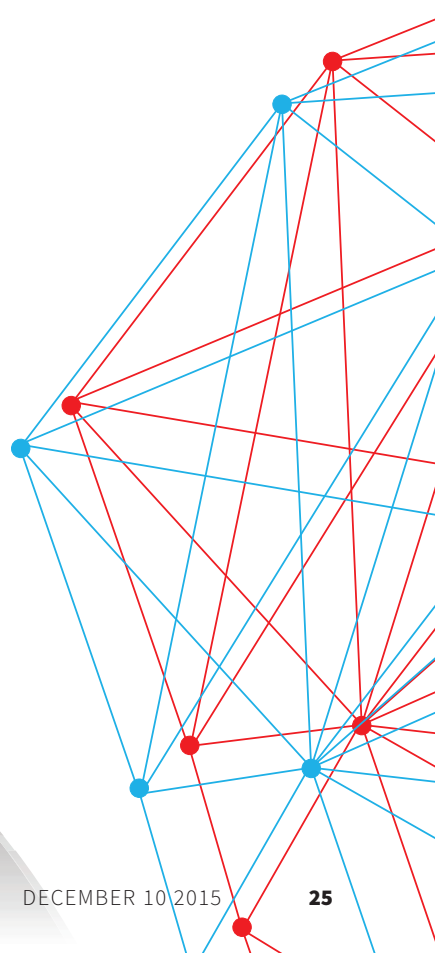
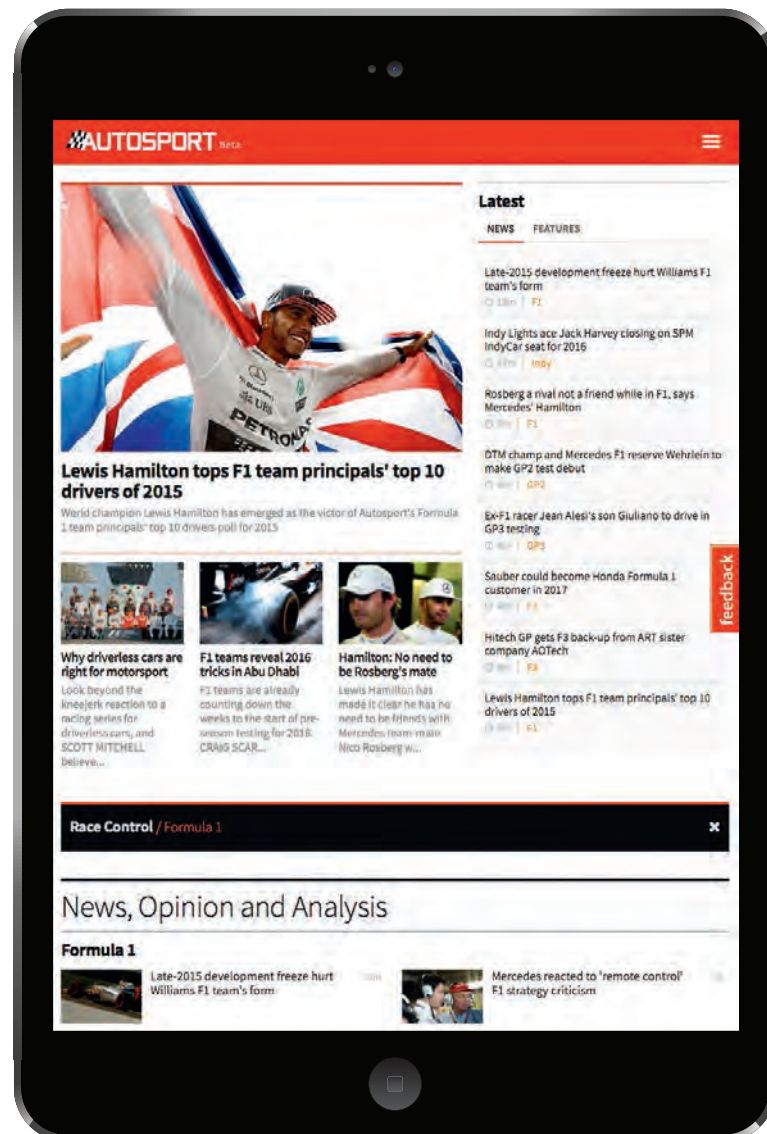

MARCH



Testing smash put Alonso out of Oz race



Horner unhappy with Renault from the start

March began in headline-grabbing fashion. A wheel had not even turned in anger when, three days in, it was confirmed that **Fernando Alonso would not race in the season-opening Australian Grand Prix.**

Alonso was advised by doctors not to race at Melbourne's Albert Park due to a concussion the double world champion had sustained in a testing accident in Barcelona in February. Although a McLaren statement declared Alonso to be "fit and well" and "ready to race", the Spaniard sat out the event "to minimise the chances of second-impact syndrome", at worst fatal should another concussion occur. The reaction in some quarters as to what unfolded with Alonso over this period of time was somewhat hysterical, with all sorts of rumours flying around.

Into Alonso's place stepped **Kevin Magnussen**, the young Dane demoted to reserve for 2015 after racing in 2014. Magnussen, however, never even made it to the startline as his Honda engine shut down, and neither did Red Bull's Daniil Kvyat. Only 15 cars started as Williams's **Valtteri Bottas was ruled out** with a back injury sustained during qualifying, while **Manor failed to take part** in any session and only narrowly avoided FIA sanctions.

In its favour, the team had only just been hauled out of administration in late February, with Ovo Energy founder Stephen Fitzpatrick emerging as saviour.

Just 11 cars finished, with Lewis Hamilton spearheading a Mercedes one-two, and Sebastian Vettel finishing third on his Ferrari

debut. Felipe Nasr also gave Sauber a boost with fifth at his debut race for a team whose race weekend was overshadowed by goings on in the **Supreme Court of Victoria involving Giedo van der Garde.** The Dutchman claimed he had legal rights to race, only to withdraw his dispute after coming to an arrangement with the team.

A fortnight later in Malaysia, Alonso and Bottas were back. Remarkably, the **race was won by Vettel**, giving Ferrari its first victory for almost two years.

Lurking in the background throughout the month were rumblings of **discontent from Red Bull** with engine supplier Renault. The calendar was confirmed at 19 races, with the FIA officially **cancelling the German GP** that was due to be held at the Nurburgring.



Fifth in his debut race, Nasr lifted Sauber team spirit

APRIL

Following two sobering performances in the season-opening races in Australia and Malaysia, Red Bull owner **Dietrich Mateschitz pulled no punches**, saying “we’ll only stay in Formula 1 if we have a competitive team, and we need a competitive power unit for that.”

It was another bodyblow for Renault, with Mateschitz going so far as to suggest the French manufacturer **should withdraw from F1** if it could no longer remain competitive.

Such remarks naturally prompted furious debate as to whether Mateschitz was serious or bluffing, albeit prompting remarks that if anyone knew the Austrian he was not someone who indulged in kidology. With Kvyat retiring with an engine problem early on in the next race in China – as did Toro Rosso’s Max Verstappen – and Daniel Ricciardo only ninth, team principal Christian Horner unusually opted to haul Renault managing director Cyril Abiteboul into his post-race media briefing.

An uncomfortable-looking Abiteboul conceded that **Renault was aware it had “reliability weaknesses”** with its first engine, but they would be addressed by the race in Monaco in late May.

Abiteboul said: “It is all about understanding each other’s philosophy and supporting each other rather than dragging each other down.”

Matters failed to improve in Bahrain, though, where Ricciardo retired with a last-gasp failure, resulting in him moving on to **his fourth and final allocated engine of the year** for the next race in Spain.

Honda’s problems were also acute, with **Button not starting in Bahrain** due to an energy-recovery-system failure, the culmination of a wretched weekend for the Briton as he also had problems in both Friday free practice sessions and early in qualifying.

The failings resulted in Alonso calling on the team to instigate a “very deep investigation” into the problems.

Further calendar news emerged, with **Australia announcing an April 3 date for 2016**, providing F1 with its latest start to a season since 1998. F1’s newcomer – the **European GP in Azerbaijan capital Baku** – was pencilled in for July.

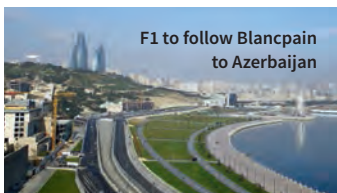

F1 to follow Blancpain to Azerbaijan

XPBIMAGES



Verstappen Monaco crash inadvertently cost Hamilton the win

MAY

At last, the often-maligned Strategy Group, which, according to Bernie Ecclestone, usually agrees on nothing but the date of the next meeting, emerged from a session at Biggin Hill with proposals for an F1 revamp in 2017.

Self-interest was, for once, put to one side as **measures were revealed to reduce lap times** by five to six seconds through aerodynamic changes, wider tyres and a reduction in car weight. Higher-revving engines and an increase in noise levels were also announced, as well as the return of refuelling, which had previously been banned from 2010.

Despite drivers supporting the **refuelling proposal** it was an idea that failed to burn brightly for long as not only were cost implications soon realised, but it became apparent there would be no major benefit to the show. By early June the idea was shelved, with one unnamed paddock observer noting: “It was so obvious it was a non-starter even a blind man could see it.”

Following a routine victory for Nico Rosberg in Spain, **Michelin threw its hat into the ring** for the next tyre supply contract to run from 2017-19. Ecclestone pretty much determined the result from the outset when he derided the French manufacturer, suggesting all they would do is “make a rock-hard tyre you could put on in January and take off in December because they don’t want to be in a position where they can be criticised”.

Ahead of the Monaco GP, Hamilton gave himself the ideal tonic when he and Mercedes **confirmed the signing of a new multi-**

million-pound contract through to the end of 2018. But after taking Monaco pole for the first time in his F1 career, the win that seemed certain to follow for 64 of the 78 laps, as Hamilton controlled the race, was undone by a **pitstop blunder**.

Following a **crash involving Verstappen**, Mercedes came in for fresh tyres, only for him to emerge behind Rosberg and Vettel. The look of bewilderment on Hamilton’s face come the finish was a picture, with his terse remarks providing added zest to another Monaco to primarily forget given the furore that unfolded between him and Rosberg in 2014.

Minnow **Manor** remembered Monaco in all the right ways, with each team member sporting a bright-red wristband bearing the words **‘MONACO 2014. P8. #JB17’**.

That was in recognition of former driver Jules Bianchi scoring what remain the team’s only points the previous year, and with the Frenchman hospitalised in a nearby facility in Nice following his horrific accident in Japan eight months previously.



Lewis knew Monaco win should have been his

TEE/LAT

XPBIMAGES

Hulkenberg's Porsche win certainly got everyone in F1 talking about Le Mans



JUNE

Arguably the biggest story of this month was what an F1 driver accomplished away from a grand prix weekend, with Force India's **Nico Hulkenberg** winning the Le Mans 24 Hours.

Sandwiched in between the races in Canada and Austria, Hulkenberg realised a long-held ambition by competing in one of motorsport's blue-riband events.

Driving for Porsche in the German manufacturer's additional entry, alongside Nick Tandy and Earl Bamber, Hulkenberg and his team-mates scored a surprise victory.

Come the following weekend at the Red Bull Ring, Hulkenberg was the talk of the paddock, with his success sparking a **flurry of interest from other drivers** about one day competing at Le Mans. Alonso confirmed he was "very close" to a seat with Porsche,

while Vettel, Raikkonen, Ricciardo, Maldonado, Grosjean and Sainz all said they hoped one day to race at Le Mans.

Given Alonso's remarks during a miserable race in Canada, the suggestion from the Spaniard at the time was that his chance could not come soon enough. After being initially told to save fuel, the double world champion replied: "I don't want! I don't want!", before adding he was **"looking like an amateur"**.

Given the litany of problems being experienced by McLaren-Honda, **Alonso then suggested the pairing should start to "concentrate on next year's performance"**, as earlier boasts as to the progress the team would make over the year by Honda motorsport boss Yasuhisa Arai were all sounding very hollow. Eric Boullier went so far



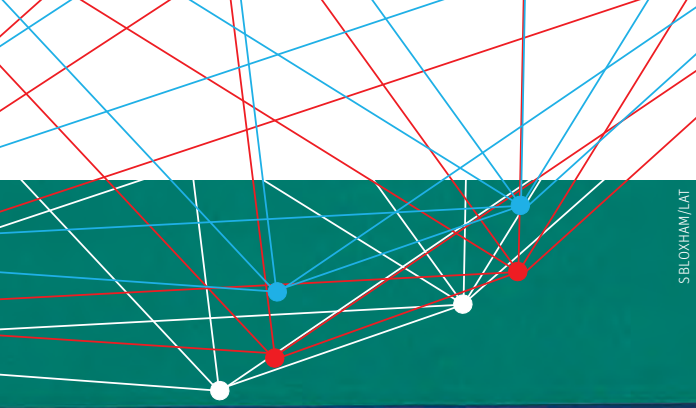

SBL0XHAM/LAT



as to suggest if the issues were not addressed soon, **McLaren's 2016 campaign would also be affected.**

To rub further salt into Alonso's wounds, he was involved in a **lap-one crash in Austria with Raikkonen** as the Finn lost control of his car, the McLaren ending up on top of the Ferrari.

It was also in Austria that **Mateschitz delivered another damning indictment of Renault**, suggesting its poor performance had "destroyed" his team's enjoyment of F1.

Away from the track, Michelin officially threw its hat into the ring for the tyre tender. Ecclestone, never shy in expressing an opinion, **found himself on the receiving end of some stern remarks** from FIA president Jean Todt, who told the 85-year-old to keep his critical comments on F1 to himself.



Farewell to Bianchi

AP

JULY

The **F1 world mourned the death of Jules Bianchi** at just 25, the Frenchman passing away on Friday July 17.

The tragic news brought to an end Bianchi's nine-month fight for survival in the wake of his horrific accident during the Japanese Grand Prix in September last year.

Bianchi had been in a coma since the accident, which involved him colliding with a recovery vehicle in the severe wet conditions at Suzuka while racing for Marussia.

Bianchi had been transferred from a hospital in Japan to a facility in his home city of Nice a month after the accident.

On Tuesday July 21, **Bianchi's funeral was held** at the Sainte Reparate Cathedral in Nice, with hundreds of mourners present to pay their last respects. F1 drivers Hamilton, Button, Vettel, Grosjean, Rosberg, Massa, Ricciardo, Kvyat, Maldonado, Ericsson and Merhi, along with FIA president Jean Todt, all attended. At the following race in Hungary, a minute's silence was held on the grid.

It was an emotional build-up that affected some more than others ahead of what proved to be a chaotic race at the Hungaroring as there were incidents galore. **Hamilton and Rosberg ended up sixth and eighth, way behind winner Vettel**, the first time neither of the Mercedes duo had finished on the podium since the 2013 Brazilian Grand Prix. With Vettel claiming his second win of the season – which he dedicated to Bianchi –



Seb's second win of the year in Hungary and no Merc in sight

STALEV/LAT

to leave him 42 points adrift of Hamilton going into the summer break, the four-time champion suggested it was 'game on' in the title race.

Force India introduced its long-awaited B-spec car, unveiled previously at Silverstone, but both Sergio Perez and Nico Hulkenberg suffered big crashes after suspension and front-wing failures respectively.

Elsewhere, **Sauber confirmed its driver line-up for 2016**, retaining Marcus Ericsson and Felipe Nasr.

The **FIA approved a record-breaking 21-race calendar** for 2016, starting on April 3 in Australia, but with no full three-week summer break as per recent seasons. Motorsport's governing body also revealed details on **new starting procedures**, placing the emphasis on race starts back in the hands of the drivers and away from the pitwall.



The reality of losing Bianchi hit home in Hungary

XPBIMAGES



SBLOXHAM/LAT

AUGUST

After months of speculation, where it was suggested his form was no longer good enough for Ferrari or Formula 1, **the Scuderia confirmed it had re-signed Kimi Raikkonen for 2016.** After finishing a miserable 12th on his return to Ferrari in 2014, albeit in a car far from his liking, Raikkonen's first half of 2015 in comparison to new teammate Vettel was hardly inspiring, aside from a runner-up finish in Bahrain.

It resulted in numerous names being placed in the frame to replace him, most notably fellow Finn Bottas, and to a lesser extent Hulkenberg, Ricciardo and Grosjean. But **the relationship between Vettel and Raikkonen proved a deciding factor**, according to team principal Maurizio Arrivabene, providing the team with "further stability".

Arrivabene made clear, though, that in placing "great confidence" in him, Ferrari expected to be "well rewarded", adding to the pressure on Raikkonen, then 35.

Returning to racing after F1's three-week summer break, the Belgian GP was **overshadowed by the latest tyre controversy.** Rosberg was the first to suffer when his **right-rear tyre exploded** on his Mercedes in second practice, with a Pirelli investigation concluding an external cut caused a high-speed spin.

On the penultimate lap of the race, **Vettel's right-rear tyre also blew** as he headed down the KEMMEL Straight with third place in his sights.

The German was furious post-race, slamming **Pirelli's performance as "unacceptable"** and forcing the Italian manufacturer into an in-depth investigation.

Lotus's financial situation was laid bare as the team's trucks and cars were impounded after the race by Belgian police thanks to **Charles Pic taking out a court order** on the basis his contract had not been honoured.

By the end of the month it emerged Lotus was in financial limbo as it was in talks with Renault with regard to the French manufacturer acquiring a majority stake and again becoming a full works team in 2016.

With a due-diligence process under way, this prevented Lotus from undertaking any deals with suppliers, and in turn restricting development on the car.

Solo track invasion during the actual race led to the arrest of this 27-year-old



SEPTEMBER

The saga between Red Bull and Renault took a new twist as it emerged the team had decided to **sever its ties** with the French manufacturer at the end of the campaign, a year ahead of the expiry of its contract.

Red Bull had become so disenchanted with Renault, less than two years after its engine supplier had helped the team clinch its fourth consecutive constructors' and drivers' titles. Renault CEO Carlos Ghosn said his company would honour its contracts, but spelt out its days as an engine supplier were over beyond 2016.

In terms of where to turn for Red Bull, one potential new supplier opted against stepping into the breach.

Mercedes motorsport boss Toto Wolff had earlier suggested the idea was not "off the table" as he could see the pros and cons, only for the Merc board to ultimately **veto the possibility of supplying a major rival.**

With Ferrari seemingly the only option, **Horner said it was up to him "to find a solution"** as Mateschitz was now "somewhat disillusioned", and Niki Lauda suggested his fellow Austrian had **"lost interest"**.

Renault did at least confirm one rumour: it had signed a letter of intent regarding **"the**

potential acquisition" of Lotus.

It followed two visits to the High Court for the team over **unpaid PAYE to HMRC, amounting to £2.7million**, albeit with the judge in the case offering adjournments as the two parties thrashed out a deal.

Lotus suffered the ignominy of being locked out of its hospitality unit over the weekend of the Japanese GP for not paying its bill.

Following the incidents at Spa, **Pirelli revealed its findings** in the build-up to the race in Italy, stating there had been "an exceptional number of cuts" in its tyres – 63 overall – due to "an anomalous amount of detritus on the track".

It was pressures and not cuts that caused Mercedes concern at Monza, an event that came and went with no resolution over the race's future, and with just one year now remaining on its contract.

The left-rears on the cars of Hamilton and Rosberg were found to be **under the required pressures specified by Pirelli**, but following an investigation no action was taken, allowing the Briton to keep his victory.

Numerous drivers re-signed for their teams this month, including Hulkenberg and Perez at Force India, Bottas and Massa for Williams, Maldonado with Lotus, but surprisingly **Grosjean joining Haas.**

In Singapore, a 27-year-old British national, **Yogvitam Pravin Dhokia, was arrested** and charged after walking from one side of the track to the other during the race.

This was also the month when **Force India and Sauber lodged an official complaint** to the European Union competitions commission regarding F1's governance and payment structure.

In a further tweak to the calendar, the **three-week summer break was reinstated**, but leading to an earlier start on March 20.



COATES/LAT

SBLOXHAM/LAT

Lewis Hamilton – the first Briton ever to retain the F1 crown



ETHERINGTON/LAT

OCTOBER

More than one bombshell was dropped as two of F1's heavyweights in Ecclestone and Todt displayed a rare show of unity.

At a very wet Austin, as **unrelenting rain cancelled FP2 on Friday and qualifying on Saturday**, Ecclestone revealed McLaren Group CEO Ron Dennis had blocked Honda from supplying an engine to Red Bull.

Ecclestone also disclosed why Red Bull had dropped Renault when it did, in the belief that it had a deal with Mercedes following discussions in July.

A week later, as **Mexico hosted a successful return to F1** after a 23-year absence, Todt revealed that **Ferrari had used its right of veto** to thwart plans to impose a price cap a manufacturer could charge a customer for a power-unit/gearbox package.

Todt expressed "disappointment" that Ferrari had elected to take such a route.

In response, Todt announced the FIA would be calling for expressions of interest with regard to the supply of an **independent engine from 2017**, with he and Ecclestone to force through the idea at the next Strategy Group meeting.

Unsurprisingly, Wolff voiced his opposition, claiming the manufacturers had built the current power unit



STALEV/LAT

Todt and Ecclestone, a rare show of unity

based on "what is happening on the roads", with an independent engine being "a completely different technological approach." The independent-engine concept was aired just weeks after Mercedes had **signed a supply deal for 2016 with Manor**, showing it was more than happy to support a back-of-the-grid team, just not a potential major rival such as Red Bull.

Manor had also announced a transmission supply contract with Williams for '16, suggesting it was on the

up after a difficult campaign.

But then in Mexico it emerged that team principal **John Booth and sporting director Graeme Lowdon** had tendered their resignations, along with technical consultant **Bob Bell** – who was slated to return to Lotus/Renault – and a handful of other senior members of staff.

The suggestion was the duo had **fallen out with Fitzpatrick** over the direction of the team.

Although the event at the Autodromo Hermanos Rodriguez was a showcase for

F1, with **over 300,000 fans in attendance** across the three days, the race fell flat.

That was certainly in contrast to what had unfolded seven days previously in Austin as the weather took its toll, but there was at least one hell of a race to savour from which Hamilton captured his third world title, becoming the first Briton in F1 history to retain the crown.

That followed Mercedes reclaiming the constructors' title a fortnight earlier in Russia, albeit somewhat unsatisfactorily as long after the race **Raikkonen was demoted from fifth to eighth** via a time penalty for a collision with Bottas.

The loss of the six points meant Ferrari could no longer catch Mercedes in the constructors' standings.

There was at least some good news for Hamilton's fellow Englishman Button as, following a period of speculation that he would be leaving, he and McLaren opted to **renew their partnership for '16**.

Ecclestone also let slip on the grid in Russia that **Pirelli had won the '17-'19 tyre supply contract**, while there were suggestions that Force India was on the brink of a deal that would see it **rebranded as Aston Martin Racing**.

THE ULTIMATE REVIEW OF 2015

Whilst rival F1 annuals come and go, **AUTOCOURSE** – The World's Leading Grand Prix Annual – is proud to have reached its 65th year of publication as the indisputable leader in its field.

The 19-race Formula 1 World Championship season is covered with its usual meticulous attention to detail. The vastly experienced and much-respected Tony Dodgins and Maurice Hamilton – both long-time paddock insiders – bring you all the drama and intrigue that is Formula 1. Supporting their race commentaries are detailed results spreads that include specially prepared lap charts and tyre strategies.

The 2015 season saw the continuing domination of Mercedes-Benz as a championship-winning force, and Lewis Hamilton took his third World Championship, to equal the tally of his boyhood hero Ayrton Senna.

As ever, politics cast a long shadow over the sport, and the many crises that erupted throughout the year are assessed, along with the implications for the future well-being of Formula 1.

Mark Hughes once more analyses the successes, frustrations and failures of each of the constructors in his Team-by-Team review, which includes key personnel, sponsors and technical specifications of the F1 cars, highlighted by the beautiful F1 car illustrations of Adrian Dean.

The sport's other leading categories are also given ample coverage, including the single-seat ladder from Formula 3 up to GP2, which showcases the pool of rising talent, all aiming to make their way into Formula 1.

Also described is Audi's battle with Porsche and Toyota for sports car racing's World Endurance Championship, and the typical door-banging combat that is Touring Cars, in all their respective categories. Veteran scribe Gordon Kirby gives his no-holds-barred assessment of the racing year in the United States.

AUTOCOURSE traditionally wraps up the year with the most complete record of results published anywhere in a single volume.

With a whopping 384 pages, this lavish yearbook – the largest ever – is essential reading for all fans of global motor-sport.



ONLY £43.50*
INCLUDING FREE UK secure post and packing
*RRP £49.95

To order visit: www.autocourse.com
or call our hotline: +44 (0)1753 689693

Includes **FREE** and **SECURE** pre-Christmas delivery!

Last UK order date: 17th December*

*Delivery times dependent upon order destination – see website for details



ONLY £25.00
plus secure post and packing

LIMITED EDITION GRAND PRIX CALENDAR

Icon Publishing Limited are delighted to team up with the world-renowned Cahier Archive, to produce the premium quality, large format, LIMITED EDITION, **AUTOCOURSE 2016 CLASSIC CALENDAR**.

Sized at 592mm x 420mm, in a landscape format, this sumptuous calendar is printed on 230gsm art board. It reflects Formula 1 through the ages, offering 24 images, all of which are suitable for framing.

The photographs, drawn from seven decades of Grand Prix racing, have been personally chosen by Paul-Henri Cahier, from his Cahier Archive.

To offer you incredible value for money, the calendar leaves are printed on both sides, to give you two images per month. Therefore you have the option to change them over to a personal favourite, or whenever it suits your mood.

THE GRAND PRIX COLLECTION CALENDAR IS ONLY AVAILABLE FROM www.autocourse.com

please visit our website to view all 24 images.

The calendar will be sent in early December, in a protective cardboard carton, via a tracked courier service, in time for Christmas 2015 – providing you make your order by December 17th*

“In these ten years of Formula 1, my greatest joys came from the fans.”

Ayrton Senna

WWW.AYRTONSENNASHOP.COM

Instituto **Ayrton Senna**
A portion of the revenue from Ayrton Senna brand goes to Ayrton Senna Institute.



Ayrton Senna

INTERNATIONAL SHOP

NOVEMBER

No sooner had the FIA announced its independent **engine plan than it was shot down** by the F1 Commission at a meeting in Paris.

As expected, Todt and Ecclestone joined forces at the Strategy Group, using the combined six votes apiece they hold at such meetings to push it through to the next level.

But, as was also expected, come the Commission (where all teams, stakeholders and F1 sponsors are involved) the vote went against, despite **four expressions of interest being declared from Ilmor, AER, Mecachrome and RML**.

There was, however, a caveat, with the F1 manufacturers agreeing to come up with **proposals by January 15 that would address a guaranteed supply of power units** to teams, lowering the cost to customers, simplifying the technical specification and improving noise.

Without such proposals, the FIA made clear the independent engine idea would be placed firmly back on the table.

At least the month ended with **Red Bull**



Finally a deal is made: Renault's Stoll with Red Bull's Horner and Mateschitz

COATES/LAT



Rosberg's not as good at beard-growing either

XPB IMAGES

confirming it would have an engine next year and would therefore be on the grid, although Horner refused to divulge details.

It was understood at the time Red Bull had **renegotiated the final year of its deal with Renault**, with the suggestion it would lose title sponsor Infiniti into the bargain, and the power unit rebranded as 'Nissan F1' given the alliance between the Japanese manufacturer and its French counterpart. Horner made clear the deal was not dependent on Renault's takeover of Lotus, which had yet to be completed come the end of the month.

Talks remained ongoing between **Renault and Ecclestone over constructors' bonus and historic payments**, with Renault seemingly indicating that it would leave F1 if its terms were not met.

And as the season wound down, there was some fun from Ron Dennis, who suggested he

had **"an open mind" to Alonso taking a sabbatical** in '16 should the next McLaren-Honda be as bad as this year's.

The news came as a surprise to Alonso, although when asked for his thoughts he did not rule out the proposition.

There was a minor car **crash for Hamilton in Monaco**, but at 3am and in hitting a parked car in his £2 million Pagani Zonda you can imagine the stir that created. By that stage Hamilton was arguably 'de-mob happy' given his earlier clinching of the title. Whether that played any part in **Rosberg winning the final three races from pole**, we will never know.

But when asked after finishing runner-up to Nico for the third consecutive race whether it was he or his team-mate the happiest going into the winter, Hamilton replied: "I think being **world champion sounds a lot better than race winner**". Ouch! Enough said.



Nice way to end the season for Rosberg: three poles, three wins

Mercedes

It didn't take long for last year's dominant team to prove it was also this year's supreme force. With 16 wins out of 19, the Brackley-based squad was unstoppable

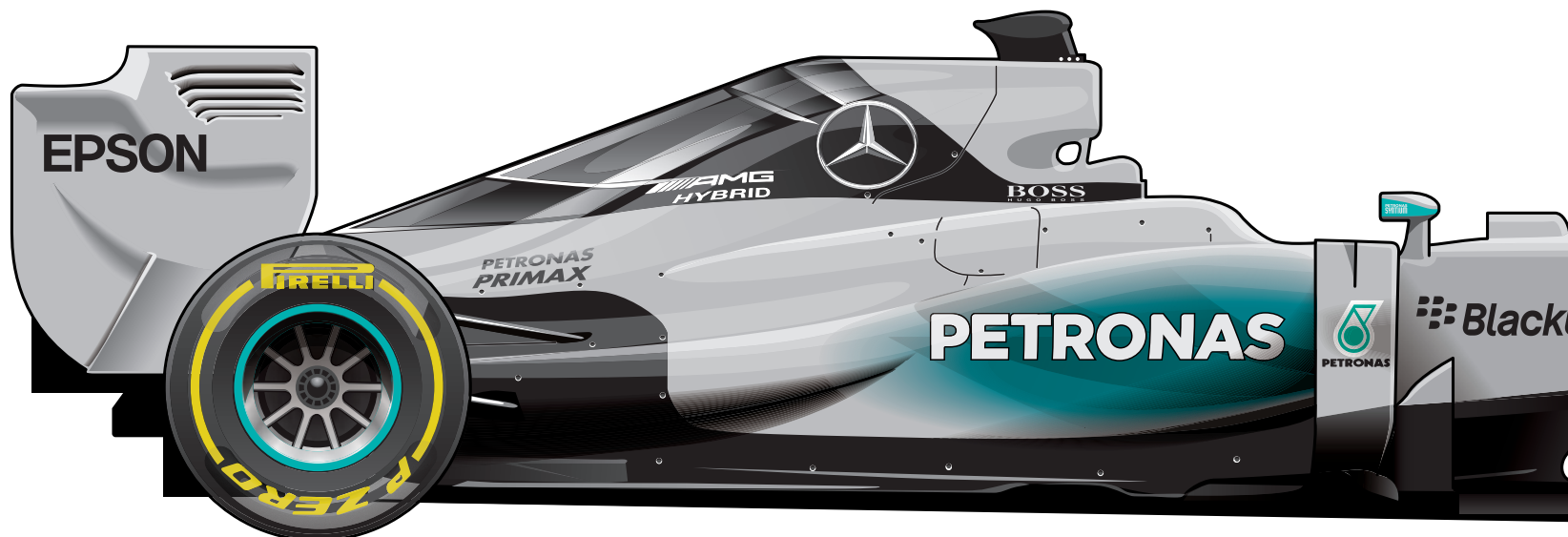

Mercedes F1 W06 Hybrid ... Championship position 1st ... Wins 16 ... Podiums 32 ... Poles

Mercedes picked up where it left off in 2014 by largely dominating F1 this season, again comfortably winning the drivers' and constructors' championships with Lewis Hamilton and Nico Rosberg at the wheel.

The W06 won 16 of 19 races, scored 12 one-two finishes (a single-season record), 18 pole positions, 32 podiums, and finished well clear of nearest rival Ferrari in the title race. This was at least as convincing a campaign as last year.

However much he might enjoy fishing, it surely must irk Ross Brawn slightly that the team he

rescued from the ashes of the aborted works Honda project, rebuilt into a title winner, then steered towards the V6 era as a Mercedes factory operation, is now cleaning up in F1 without him.

It was a nice touch from Hamilton to credit Brawn in the aftermath of Mercedes clinching its second straight constructors' title at the Russian Grand Prix, with four races to spare.

The fact that Mercedes was able to take victory on all but three circuits again in 2015 justified a development strategy that focused on maximum efficiency and producing a car that works across as broad a spectrum of tracks as

possible in these days of limited windtunnel testing time.

"You can't cover all bases," says Mercedes technical chief Paddy Lowe, whose team did not seem to follow the lead of some rivals, most notably Red Bull, in raising the rear ride height of the car aggressively relative to the front as the year wore on. "The sort of high-rake solutions would allow you higher absolute levels of downforce, at low speeds particularly, but you have to develop around it.

"When you have only so many aero runs per week, if you spend a week developing high downforce for a particular requirement you're not spending your week on

efficiency solutions globally."

Mercedes' continued advantage in the power stakes under these still-immature V6 hybrid-turbo rules was naturally a huge help, allowing the W06 to run more wing angle on conventional circuits compared to rivals, improving the car's cornering potential with less of a relative penalty in terms of drag on the straights.

The engine department at Brixworth again showed its relative mastery of the regulations by developing an engine (including what Lowe called a "substantial philosophical change of direction" in exhaust layout) that was still a step ahead of nearest rival Ferrari, and remained so throughout the season as tokens were spent on combustion upgrades to improve power and efficiency.

The W06 was also much more reliable than its predecessor, suggesting work to improve the package's cooling abilities had paid off. The unreliability that crept back later in the campaign (Rosberg's power-unit contamination at Monza, Hamilton's turbo-clamp failure in Singapore, and Rosberg's throttle-pedal problem in Russia) was in reality coincidental to its ongoing development push in the face of Ferrari's renewed threat.

The "evolutionary" W06 seemed



“Mercedes was the best package at every race except for Singapore”

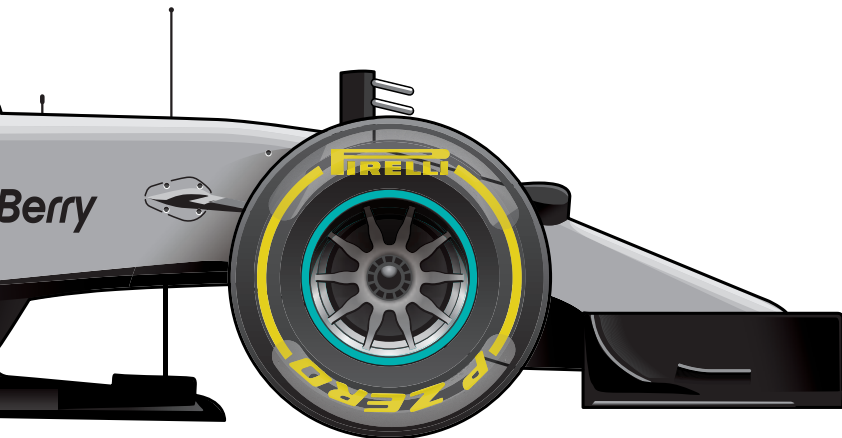

18 ... Fastest laps 13 ... Points 703



LEWIS HAMILTON



NICO ROSBERG

1st	Championship position	2nd	
Starts	19	Starts	19
Wins	10	Wins	6
Poles	11	Poles	7
Fastest laps	8	Fastest laps	5
Points	381	Points	322

The verdict

Mercedes was even more dominant than in 2014. The only serious slip was in Singapore, where Sebastian Vettel won on merit. In a way, it's worse for the rest that this happened because it will have made Mercedes have a good scratch of the head and learn about an area of weakness.

Both drivers proved the car was right on the money. It's easy to say Hamilton had the advantage over Rosberg; Nico won the last three races and might easily have won the last six – he was on pole for all of them. And you should turn pole position into a race win.

Lewis was a bit heavy-handed with



Nico at the first corner at Suzuka and Austin, but the bottom line is Rosberg has never turned as many of his poles into wins. In the final three races, he put that right. This could make things interesting at the start of next year.

GARY ANDERSON

Race by race car pace

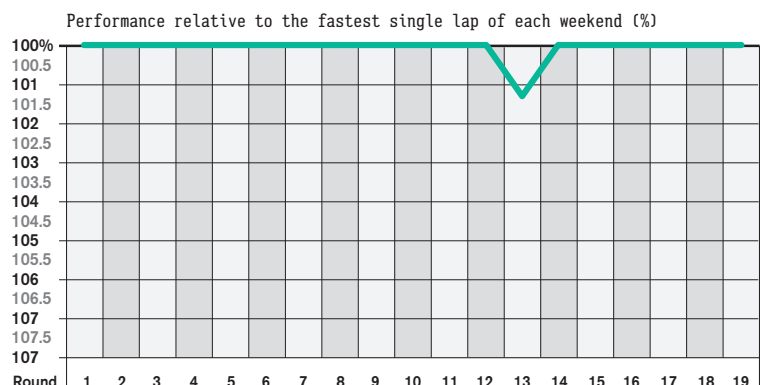

Starting as they went on: Hamilton won from Rosberg in Oz

to be especially comfortable in colder conditions, or on the hardest (medium and hard) of Pirelli's four tyre compounds. But in truth it was the most competitive package at every race apart from Singapore, where for reasons unclear it just could not get the softs and super-softs working correctly.

“We've gone round the loop and our understanding now is better than it was at the time,” says Lowe. “They [the problems] are mostly around set-up; some of it around the aerodynamics. A lot of things we could've done better...”

There were a couple of strategic

blunders, notably the call to pit under the safety car that cost Hamilton victory in Monaco, and the decision to pit both cars under safety-car conditions that handed victory to Ferrari in Malaysia. Starts were also a little shaky at Silverstone and the Hungaroring (before a mid-season rule change to ban pitwall-to-driver communication over procedures and clutch settings), but Mercedes was otherwise largely flawless.

The question is whether it has the might, money and knowhow to sustain its status in the face of a reinvigorated Ferrari. ❄

THE GREAT CAR

Mercedes F1 W06

This year, the other F1 teams were supposed to catch up with Mercedes. **Craig Scarborough** explains why its dominance wasn't threatened

Mercedes went into 2015 carrying over by far the best chassis and power unit from the previous season. Winter development therefore focused on reliability rather than any dramatic changes in concept. The W06 was immediately the fastest and most reliable car, with little visually to differentiate itself from its forebear, the W05.

Although rivals caught up in terms of power unit (Ferrari) and chassis (Red Bull) performance through the year, the W06 stayed a step ahead.

Reliability fears were largely

quashed, with just a few small issues surfacing around Nico Rosberg's throttle pedal in Russia, Lewis Hamilton's turbo-pipe clamps in Singapore, and a coolant leak that contaminated Rosberg's updated Monza power unit.

Overall, the W06 dominated F1 at least as convincingly as its predecessor, winning 16 of 19 races, starting on pole 18 times, and scoring 32 podium finishes (last year's W05 made the podium 31 times).

A double world championship victory was the just reward for a team that once again produced a truly great Formula 1 car. 🏆



Key areas

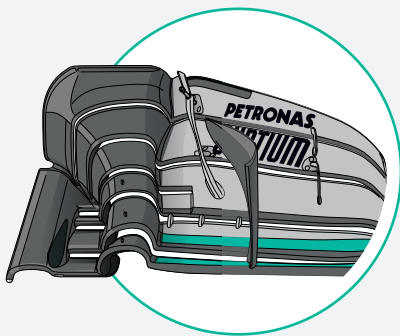

FRONT WING

Mercedes led the development trend when it came to front wings, starting with its outswept design that relied more on the wing's shape and less on aggressively twisted endplates to control the airflow around the front tyre. This created the outwash that pushed the front-tyre wake away from the bodywork of the car, making the rest of the car aerodynamically more effective. The outwash was further enhanced when the stepped leading-edge shape was adopted early in the season. By having a distinct step in the profile near the wing tips, a stronger vortex effect is created to push the airflow out around the car.

SIDEPODS

Although its power unit is one of the most efficient in terms of heat rejection, the Mercedes W06 benefited from smaller sidepods than even its customer teams. The turbocharger was cooled by a water-to-air intercooler in a recess in the back of the fuel-tank area. This came with a small weight penalty, but allowed more space in the sidepods. Having a large energy-recovery-system water cooler mounted above the gearbox, fed from an inlet in the rollhoop, reduced the size of the sidepods.

NOSE/TURNING VANES

Although following the short-nose concept to meet the new rules for 2015, Mercedes adopted a narrow rounded nose-tip shape, rather than the 'thumb-tip' design adopted by most cars. This slimmer shape fed more air to the turning vanes hanging under the front suspension. When allied to the unique 'bat-wing' vane sitting behind the turning vanes, this further aided the front wing's work in pushing the turbulent tyre airflow wake away from the car.

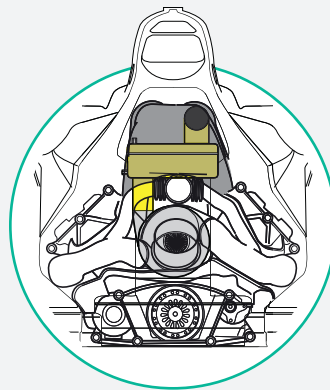
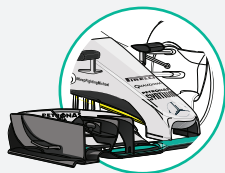

ENGINE

With a near-complete redesign over the winter to guarantee reliability, the Mercedes engine remained the most powerful and reliable unit on the grid. No major changes were made to its split-turbo format during the winter, merely a switch to a more conventional three-into-one exhaust system to feed the turbo. The Mercedes engine led the field in outright power, energy-recovery-system efficiency, driveability and fuel consumption all year. A major combustion update was introduced at Monza and, despite an initial reliability scare, the development-token spend benefited race performance for the end of 2015 and allowed Mercedes to test the basis of its 2016 power unit.

SUSPENSION

The team continued its work into hydraulically operated suspension. Even though FRIC (Front Rear Inter Connected) suspension is banned, the lessons learned with hydraulic elements supporting the suspension can still be applied, allowing supple ride over kerbs, but still providing a flat and stable attitude for the benefit of the car's aerodynamics. The W06 also continued to benefit from the flat shape of the conjoined front-lower-wishbone legs. Further optimised with the steering trackrod in line with the lower wishbone, this set-up flattened the airflow coming up off the front wing, and prevented it upsetting airflow over the top of the car to the rear wing.

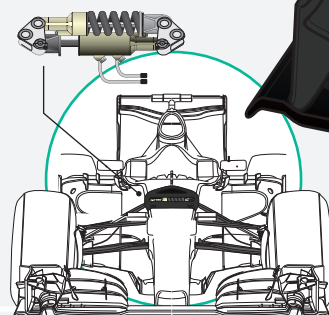

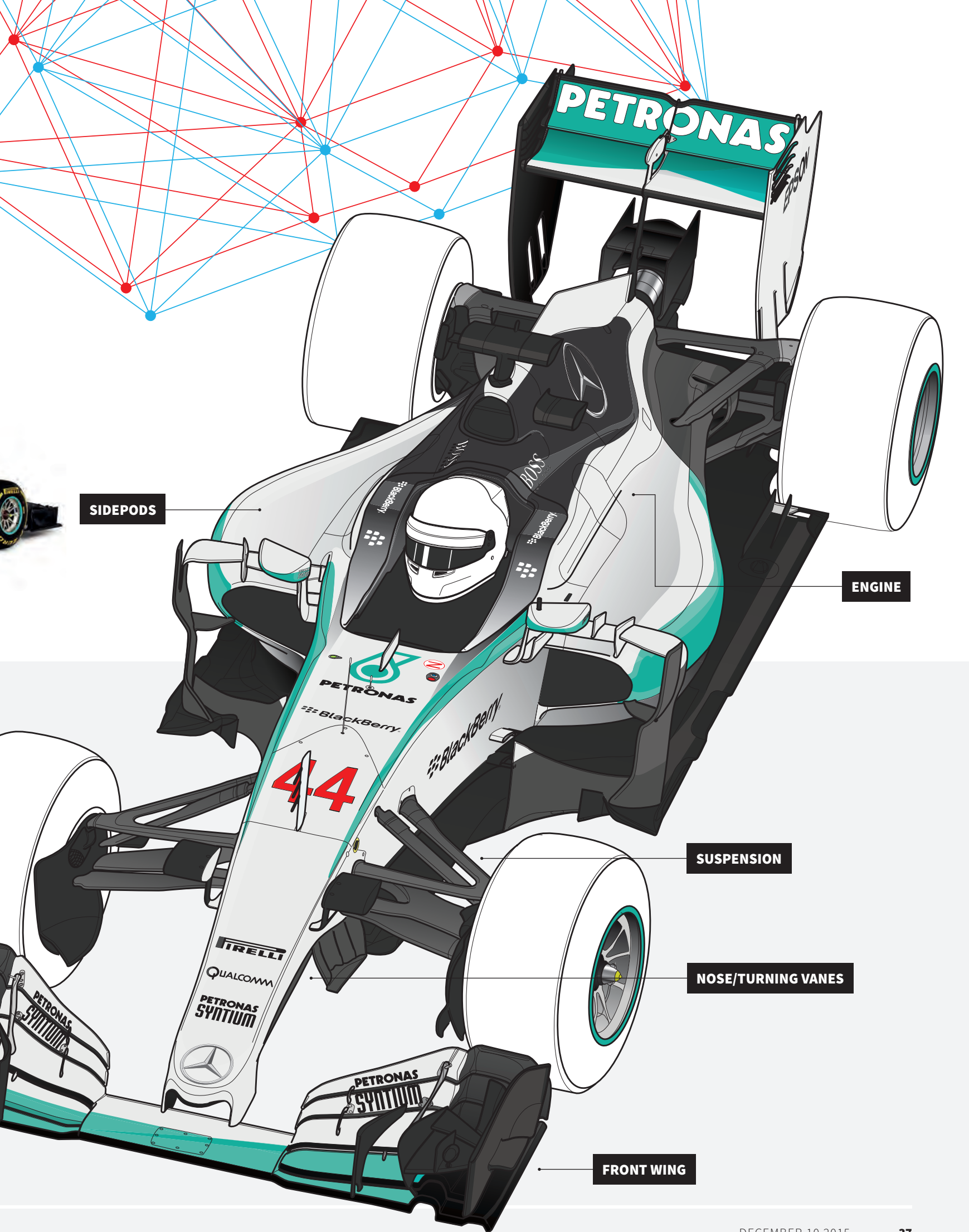

SIDEPODS

ENGINE

SUSPENSION

NOSE/TURNING VANES

FRONT WING

Ferrari

The Scuderia was snapping at the heels of Mercedes, winning three races as it completed a remarkable turnaround after last season's struggles

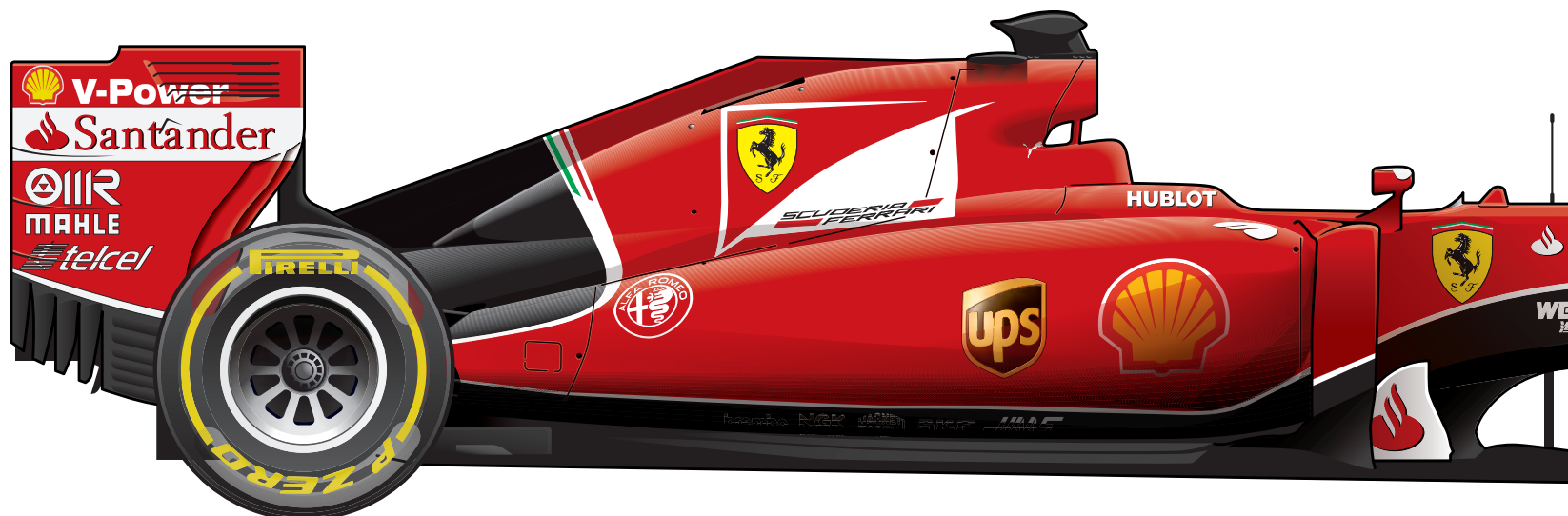

Ferrari SF15-T ... Championship position 2nd ... Wins 3 ... Podiums 16 ... Poles 1 ...

After the relative calamity of 2014, during which Ferrari failed to win a grand prix for the first time since 1993, a new broom swept through its Maranello operation, and suddenly the floors are sparkling with success again.

With the steady guidance of new team principal Maurizio Arrivabene, technical nous of James Allison, and driving brilliance of a rejuvenated Sebastian Vettel, Ferrari bounced back to record three grand prix victories and become the main threat to Mercedes.

The SF15-T was able to restore

pride to Maranello mainly thanks to huge gains made in the engine department, which was heavily restructured midway through last season, once Ferrari realised the scale of its initial failure in meeting the unique demands of the new V6 hybrid formula.

Ferrari made particular strides with its energy-recovery system, allowing it to better exploit exhaust gases for generating electrical energy and thus avoid running out of power so readily at the end of straights, which was a major weakness in 2014.

“The whole company had a much better run at 2015 than they had at 2014, so the result was a much

more competitive project,” says Allison. “Hats off to the power-unit department for recognising what needed to be done to fix it, and finding a way of doing that in a very short timescale – and where they were constrained to have to make their modifications on a platform that was largely settled already.”

Ferrari pressured Mercedes by updating the combustion engine through the season, including revised fuels that supplier Shell reckoned were worth half a second. Niki Lauda said the Ferrari power unit was a match for Mercedes’ by the end of the season, despite the Scuderia leaving four

development tokens unspent.

Pre-season, Arrivabene set Ferrari a target of winning at least two races in 2015, which means the SF15-T exceeded expectations thanks to Vettel’s trio of triumphs.

The first of those came in Malaysia, where Vettel was able to outfox Hamilton and Rosberg by completing the race on a single stop. Ferrari also reckons Mercedes was struggling with cooling the W06 in the heat of Sepang, which made the SF15-T much more competitive in the race.

Vettel’s other two wins came on the low-speed circuits of Hungary and Singapore, but in each case Mercedes could point to major errors on its part that suggest these victories were not based purely on underlying car performance.

The Ferrari generally looked very user-friendly, and both Vettel and team-mate Kimi Raikkonen consistently remarked how they felt more comfortable driving this season than they did in their respective teams last year.

At least part of this could be explained by the new, stiffer construction of Pirelli’s rear-tyre sidewall, and the rest by the “accumulation of lots and lots of little victories” achieved through car redesign.

“We had a much better run in



Vettel and Raikkonen worked well together as team-mates

“Ferrari exceeded Arrivabene’s target thanks to Vettel’s trio of triumphs”

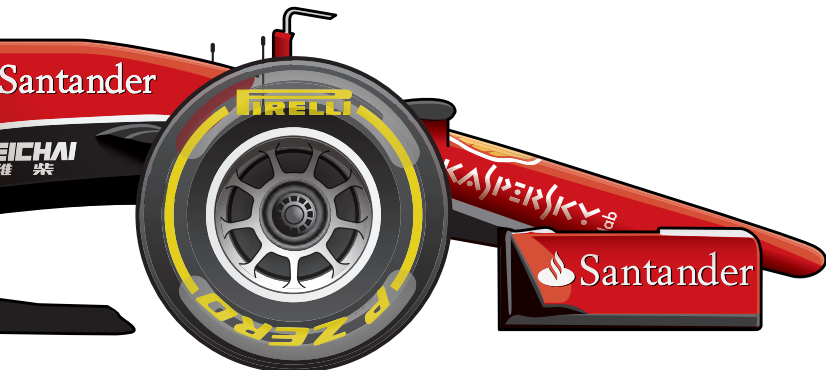

SEBASTIAN VETTEL

3rd

Starts	19
Wins	3
Poles	1
Fastest laps	1
Points	278



KIMI RAIKKONEN

4th

Starts	19
Best finish	2nd
Best grid position	2nd
Fastest laps	2
Points	150

————— Championship position —————

Fastest laps 3 ... Points 428

The verdict

The numbers show that Ferrari never really deviated far from its season-average deficit and actually ended the season very slightly further away from Mercedes than it started.

There does appear to be something lacking in the understanding of the airflow around the car’s front end. Since the major aerodynamic rule changes introduced in 2009, every team has shown that getting the nose detail correct is vitally important to the overall aerodynamic performance of the car.

The Ferrari ‘long’ nose doesn’t follow this trend and something must be leading the team in that direction.



I would not be surprised if it was the pullrod front suspension and how this affects the airflow coming out from underneath the front of the chassis.

But the power unit was a vast improvement on last year’s.
GARY ANDERSON

Race by race car pace

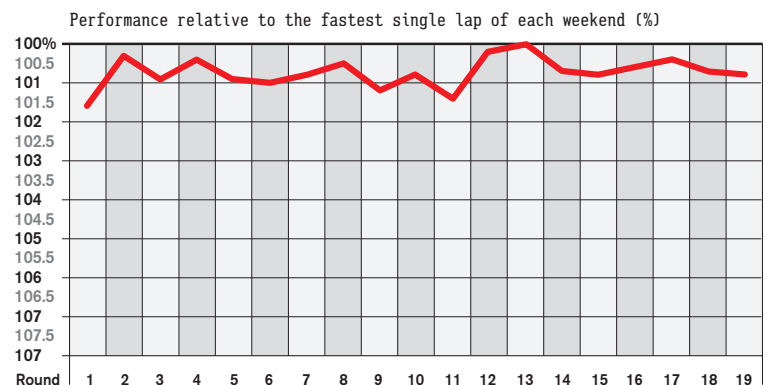

Ferrari was faster, sharper and stronger during the 2015 season

the windtunnel [this season],” says Allison. “We had a more mature windtunnel, a more mature aero department to work with, and as a result a lot more aerodynamic downforce than the previous year.”
The SF15-T was generally far stronger in race trim than in qualifying, which suggests Ferrari is still lagging behind a little in the aerodynamic and engine stakes, but Allison reckons there’s a little more to it than that.
“The normal, easy-peasy calculations of downforce, drag and power sensitivity are just not adding up to explain the shifts that

we see from track to track,” he argues. “So there’s another factor at play, and it’s who gets their tyres nicely working in what is quite a narrow window.
“I think whatever your car’s characteristics are – good or bad at a given circuit – gets amplified by that fact, and it makes it very difficult to predict exactly how well you’ll go in a given circumstance.”
Ultimately Ferrari still needs to find a little more from its aerodynamics and engine in order to fight Mercedes genuinely in 2016, rather than opportunistically, as it did this year. ✘



XPBIMAGES

‘I don’t consider myself the underdog’

Few gave Sebastian Vettel much chance of success in 2015 with Ferrari, but three wins later he’s gunning for Mercedes next season. **Ben Anderson** talks to the four-time world champion and the Ferrari technical chief James Allison



Vettel and Ferrari were back in the wins after poor 2014 seasons

It's almost as if Sebastian Vettel and Ferrari found each other in the 'lonely hearts' column of a newspaper, or carried on seeing each other after one of those terrible dating shows that Channel 4 is so fond of broadcasting.

While not exactly 'undateable', both were somewhat downtrodden in 2014, lacking some of the star quality that made each a household name in modern F1. But they got firmly back on track together this year, helping each other get over recent long-term relationships and 'back out there', as it were.

Last year was a disaster for Ferrari. The paucity of results

(including no race wins for the first time since 1993) led to wholesale changes at management level, and the departure of star driver Fernando Alonso, who lost patience with the Scuderia's inability to build a car good enough to win him a third world championship.

Jilted by its long-term lover (Alonso left after his fifth season at the team), Ferrari needed a new infatuation to rekindle the competitive fires inside Maranello.

Vettel also needed stoking. He looked out of sorts in 2014, as Red Bull went backwards after four consecutive seasons of domination. He didn't like the new V6 hybrid-turbo engines and he didn't like

what they did to the handling of his car. He got blown off by young team-mate Daniel Ricciardo and didn't look happy at all. Worst of all, he began to doubt himself...

But this year was much better. Vettel and Ferrari deleted the old numbers from their phones, and set out on a new path together that has allowed each to rediscover some of their old lustre.

A mid-2014 overhaul of the Ferrari engine department (instigated under the old regime, incidentally) bore serious fruit this year, as the SF15-T proved to be far more efficient and better at energy recovery. This was the main area of weakness last year, and solving

it delivered what technical director James Allison described as a "crap-load of horsepower" (along with further refinements to other parts of the engine, and the fuel as well).

The car was also much more benign to drive than last year's, combining well with Pirelli's stiffer rear-tyre construction to make the handling "a little bit less front-limited", according to Allison.

Vettel prefers a car with which he can lean heavily on the rear tyres, and he thrived in this new environment, revelling in a machine he enjoyed driving, while also setting out on a new career path that follows a similar trajectory to that of his hero, seven-time >>



Vettel and Ferrari seem the perfect match



Vettel won from pole in Singapore



The German appears more relaxed at Ferrari

champion Michael Schumacher.

Refreshed, revitalised, rejuvenated, Vettel showered his new lover with gifts: a podium finish first time out in Australia; a win on just his second start in Malaysia; a total of three victories and 13 podiums in their first 19 races together. Vettel finished off the podium in just four races, and only twice failed to bring the car home at all (when his rear tyre failed at Spa, and when he crashed uncharacteristically in Mexico).

Whenever the works Mercedes of Lewis Hamilton and Nico Rosberg slipped up, it was usually Vettel waiting to pounce. Witness his sublime pole position in Singapore (where Mercedes couldn't get the tyres working properly), or the two occasions across the first four races when he split the two silver cars in qualifying, thanks to Rosberg's early-season Saturday struggles.

Winning three races exceeded the expectations set for Ferrari by chairman Sergio Marchionne and new team principal Maurizio Arrivabene at the launch of the SF15-T in January. By any measure, this was a superb first season together for Vettel and Ferrari.

"I think in general this season surprised a lot of people, and surely exceeded our expectations as well," says Vettel. "So it has been all-in-all very positive.

"Obviously what people remember of last year is pretty bad, but it was not a disastrous year. I

don't think I was getting lazy, but it started more complicated, with not a lot of running and a new generation of cars. It was difficult to find the rhythm. It was not a good season overall, but it reminded me to keep going, make progress and want something new. Though changing teams has been a huge challenge, I am enjoying it a lot. Ferrari has helped me find that rhythm."

Back in the groove, Vettel has looked more like the driver who dominated Formula 1 from 2010-'13 – lightning fast at the crucial moments, relentless in the races, and almost mistake-free. It's important not to underestimate the galvanising effect a change of scenery can have on both team and driver, and Vettel has certainly impressed Ferrari with his attitude and work ethic, as well as his performances on-track.

"It's quite difficult to talk about this without sounding cliched, or without sounding boring, or even sycophantic to be honest, because it's very easy to slip into cliches like 'he's got a great work ethic'; 'he's a good team player';" says Allison of his new charge.

"I'll repeat something I wrote a while back, which is that the main thing a team wants from a driver is that they're quick. You can tolerate all manner of idiosyncrasies if the guy is quick. Quick, mistake-free and just a datum that you can trust; that you know if the car is

slow it's because the car is slow, it's not because your driver is having an off-day. I think all world champions have that, and Sebastian definitely has that.

"What you hope for in addition, which you absolutely have no guarantee of having, is someone who loves being part of the team, helps encourage the team to do better than it did before, who is forgiving of mistakes, who shows humility himself, who is fun to be with, and just lubricates what is a very difficult working environment with his personality.

"If you have the speed and the reliability [in a driver] you're already a lucky team; if you have this third thing, something which was very strong with Michael – he was tremendous in the team like that – then you really do have a special guy, and Sebastian has that. He is a very formidable weapon to have."

Vettel looks relaxed and happy in his new relationship, often taking opportunities in the post-qualifying and post-race press conferences to wind up the two Mercedes drivers (his questioning of Hamilton and Rosberg as to whether they would drive into each other at Turn 1 in Mexico

was particularly hilarious). But it's easy to laugh and joke around when things are going well and the pressure (to some extent) is off.

Ferrari and Vettel knew they wouldn't be in a position to challenge for the championship this season, the focus was simply on becoming competitive again, and Vettel seems to have enjoyed being the valiant underdog this year, shorn of the (unrealistic) expectation of defending his fourth

world title, which seemed to weigh him down during his final season with Red Bull.

"I don't consider myself the underdog," says Vettel, refuting the tag. "I know we're not the favourites, but I think we have shown since the beginning of the season that if we get our act together we have a reasonable chance of finishing on the podium and winning races.

"It has been a great experience so far, but we also know where we want to be in the future, so there is a lot of work still ahead of us, and certainly we will be a lot happier if people wouldn't call us the underdog, but favourite in the future."

However he feels about it, Vettel was the underdog this season. Ferrari made a massive leap technically, but not big enough to challenge Mercedes on merit. Those occasional successes over the Silver Arrows all required some form of slip-up or misfortune to strike first.

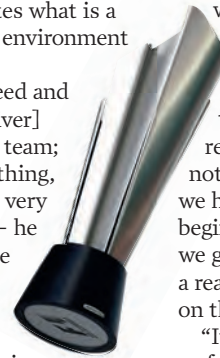

2015 Ferrari suited Vettel's driving style



Three wins exceeded expectations



A win in Sepang in Vettel's second race for Ferrari



Opportunistic wins made the most of rivals' misfortune

COATES/LAT

Raikkonen improves on his 2014 results, but the questions remain



STALEY/LAT

“All three of Vettel’s wins were the definition of underdog glory”

In Malaysia Mercedes gave up track position under an early safety-car period and couldn't recover; in Hungary Hamilton and Rosberg failed to get off the line properly and again handed track position to the red cars; and in Singapore they were not competitive in qualifying or the race owing to their difficulties in generating sufficient tyre temperature in the soft and super-soft Pirellis.

All three of Vettel's victories this year were opportunist, the very definition of underdog glory. This is something his predecessor Alonso became all too familiar with during his own stint at Maranello. True, Alonso came close to winning the world championship twice during that time, but ultimately he never did.

The Spaniard won races in every year he raced for Ferrari, except the last one, and three times finished runner-up to Vettel in the points. He was the living embodiment of the heroic underdog during his spell at Ferrari.

Triple world champion Jackie Stewart talks of how winning

races in a car that isn't the best is something that elevates a driver into the echelon of F1's greatest.

Among the current breed, Hamilton has done that, during his latter McLaren years, and Alonso too. Now it's fair to say that Vettel has clearly shown he's more than simply a one-trick bull.

But the status of heroic outsider, achieving against the odds, eventually wears thin on a driver who has been world champion before, and is driven to do nothing else except win again.

The warning of Alonso's time at Maranello is clear: spend too long as the underdog and cracks in the relationship will start to appear.

Winning occasional races in a car that isn't the best can offer an enormous amount of pleasure for a while, but that won't be enough in the long run...

So far, Vettel and Ferrari appear to be a match made in heaven. But they are both still very much in the honeymoon phase of their new union together.

It remains to be seen whether these two are simply a flash in the pan, or made for life. #

THE 2014 SEASON WAS A TRYING one for Kimi Raikkonen fans. The Finn remains an undoubted hero of the Formula 1 faithful, but last season was comfortably his worst since he arrived in F1 in 2001, as Formula Renault UK champion.

Purely based on results, this one has been substantially better. Raikkonen has finished on the podium three times (last year his best finish in a race was fourth) and scored more than double the number of points he amassed last year, improving from a lowly 12th in the 2014 standings to a much more respectable fourth.

But this season still represents another campaign of underachievement for the 2007 world champion, who was comprehensively outqualified, outraced and outscored by team-mate Sebastian Vettel.

Vettel won the intra-team qualifying battle 13-3, discounting June's Canadian Grand Prix, where Vettel suffered an MGU-H problem, and the Belgian and Mexican GPs, where Raikkonen's car broke down. That's a similar ratio to the one by which Fernando Alonso defeated Raikkonen last year. Vettel won three races and finished on the podium 13 times in 19 races; Raikkonen managed no wins and just two podiums...

By rights he should not have beaten Williams driver Valtteri Bottas (with whom he had two separate collisions this year) so narrowly in the drivers' championship, but at least he has improved his overall scoring ratio compared to his team-mate – up to 54 per cent of Vettel's points tally this year from 34 per cent of Alonso's in 2014. That ratio would be better still without a few technical problems, but Raikkonen also admits he has simply made too many mistakes this year.

When the constructors' fight is closer than it was this season, Raikkonen could prove expensive to Ferrari, but the Finn did enough to convince the Scuderia that he is worth keeping for another year, earning a contract extension for 2016 that was announced ahead of August's Belgian GP.

“I'd say from Spa onwards it's been a mighty close-run thing,” says technical chief James Allison of the internal battle between Raikkonen and Vettel. “I think we're very fortunate to have drivers that a) get on with one another, b) trust each other, c) are fast and d) are putting pressure on each other.”

All told, Raikkonen was better this season, but not much better. He needs to step up his game to really put the pressure on Vettel in 2016.



Vettel led from the start in Hungary



Vettel will be looking for bigger progress from Ferrari in 2016

Williams

For the second consecutive year, Williams was a podium threat and finished third in the championship – but it was again unable to claim its first win since 2012

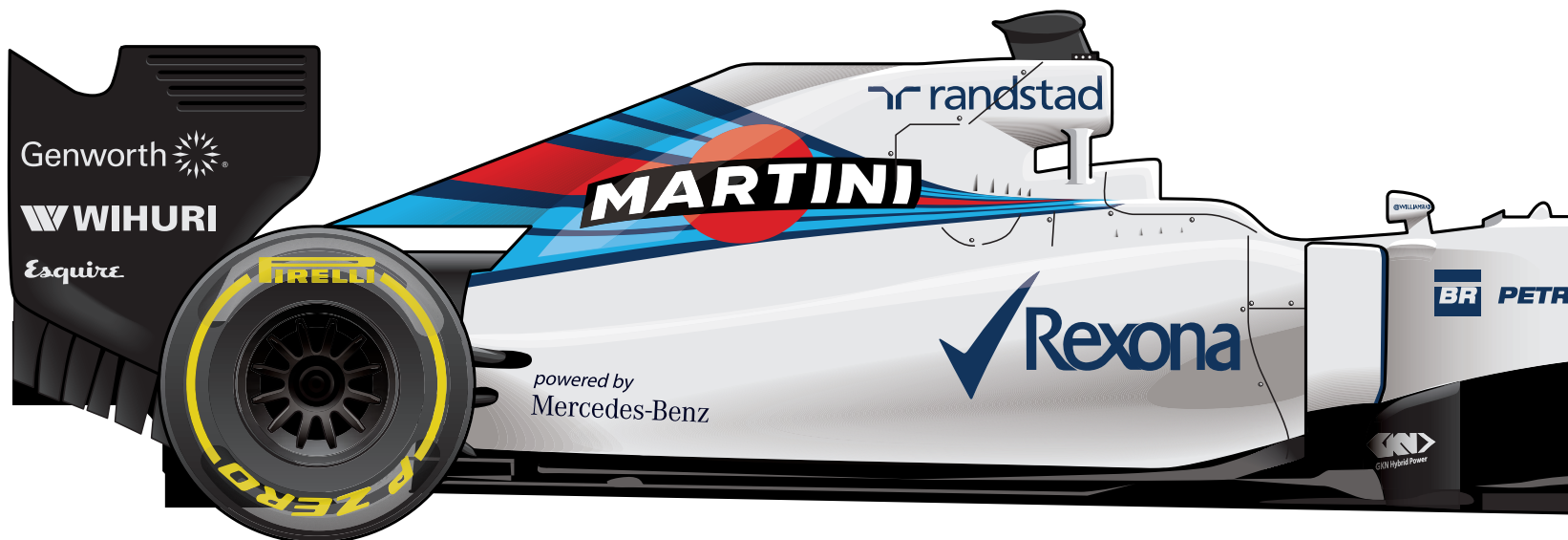

Williams-Mercedes FW37 ... Championship position 3rd ... Best finish 3rd ... Podiums 4 ...

Williams will probably look back on this season with mixed feelings.

On the one hand it comfortably finished third in the constructors' championship for the second year in a row, but there will no doubt be some frustration that it wasn't as relatively competitive compared to Mercedes as it was in 2014.

The team developed last year's FW36 impressively, and arguably finished the campaign with the second-fastest car on the grid, but was overtaken by a resurgent Ferrari in 2015. The struggles of Red Bull-Renault and McLaren-

Honda at least allowed Williams to maintain its overall standing, which represents an excellent return for a customer team of its modest resources.

Williams led the way in terms of redesigning the nose to meet the FIA's stringent new regulations. The FW37 was first to feature a short design that took the likes of Red Bull and McLaren much longer to crash-test successfully.

"I was proud we managed to get a short nose working from the start of the season," says technical chief Pat Symonds. "Williams is very good at predictive crash testing. We ended up with a nose 20-25mm longer than we actually wanted

from an aero point of view, but considerably shorter than most. It's very challenging to get the nose that short, but the gains are there if you can do it."

After the success of 2014, which featured a pole position and nine podiums, Williams understandably sought to evolve this year. The FW37 was particularly strong at high-speed circuits with long straights, but results were not quite as impressive, not helped by Ferrari's improved form.

Nevertheless, Williams produced a car that was arguably more consistently competitive across the balance of the season, and able to genuinely challenge

(and sometimes beat) Ferrari in Australia, Spain, Canada, Austria, Japan and Russia.

"They took the biggest step from last year," reckons Symonds. "That power unit now is really not far from Mercedes. We are probably still a little bit better on [ERS] deployment. They are better than us in low-speed corners – that's still a little bit the Achilles' heel.

"Our car comes out of the corners very well now, which was an area we had to work on hard last year, but mid-corner and entry to the low-speed we're still not where Ferrari or Mercedes are. I think we're still maybe a fraction ahead of Ferrari in the quick corners, where you're really exercising the downforce, but definitely not where Mercedes are."

Williams genuinely challenged Mercedes at July's British Grand Prix, but only by dint of getting both its cars ahead of Lewis Hamilton and Nico Rosberg at the start. Otherwise, the FW37 was generally the third-best car, except at the particularly slow-speed circuits in Monaco, Hungary and Singapore, and during the final leg of the season in Brazil and Abu Dhabi, where it slipped behind Red Bull and Force India. Part of this struggle was mysterious, but an early switch of focus to its 2016



Massa had his high points, but teammate Bottas prevailed

“The Williams was the third-best car, except at low-speed circuits like Monaco”

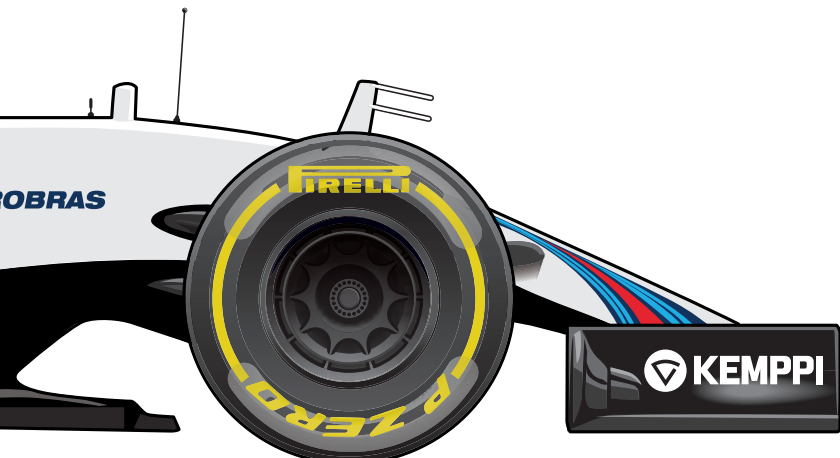

Best grid position **3rd** ... Fastest laps **0** ... Points **257**



VALTTERI BOTTAS

5th

Championship position

6th

Starts **18**
Best finish **3rd**
Best grid position **3rd**
Fastest laps **0**
Points **136**



FELIPE MASSA

Starts **19**
Best finish **3rd**
Best grid position **3rd**
Fastest laps **0**
Points **121**



Frank Williams oversees a team back on the up

challenger played a part.

Symonds and performance chief Rob Smedley talk often about the need for Williams to be sharper operationally if it wants to become a championship challenger again, and there were many times where it seemed pit work could have been much better, especially when a medium tyre was fitted alongside three softs to Valtteri Bottas's car at Spa. The sight of a Williams with a sticking wheel in the pits was also all too frequent.

“The team operationally is better, but we've probably made a few too many mistakes this

year,” laments Symonds. “We still need to improve. We've moved in the right direction and certainly strategically we're sharper now.”

There was some private unhappiness within Williams at not receiving the latest specification of Mercedes engine for the final five races, but the harsh reality of being a customer team means you sometimes have to simply make do. Williams certainly made a lot from the tools at its disposal this season, even though it couldn't yet take that next step to becoming a genuine title contender. ❄

The verdict

Williams was probably the team whose performance fluctuated most according to the circuit. The Williams-Mercedes FW37 has not been good in the low-speed corners – looking at Monaco, for example, it struggled badly there.

Williams has the best engine in the pitlane and is a strong team, but consistency is letting it down. This needs to be addressed over the winter or it could easily slip backwards in the constructors' championship after finishing third for the past two seasons.

Yes, Williams ended the year with a performance ‘loss’ according to our numbers, but this is heavily influenced



by the fact that the team stopped developing its 2015 car once it felt third place in the constructors' points was safe. All in all, third is a good return but there are still problems that must be ironed out for the team to win again.

GARY ANDERSON

Race by race car pace

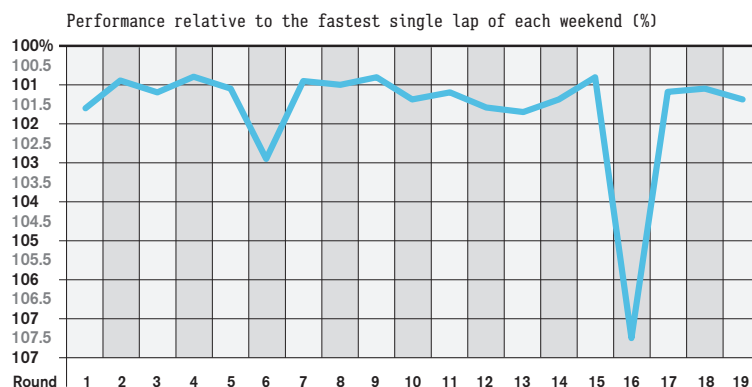

Red Bull

Last year was back to reality for the once-dominant team, but the 2015 season was a nightmare as it was overrun by engine politics and results were very patchy

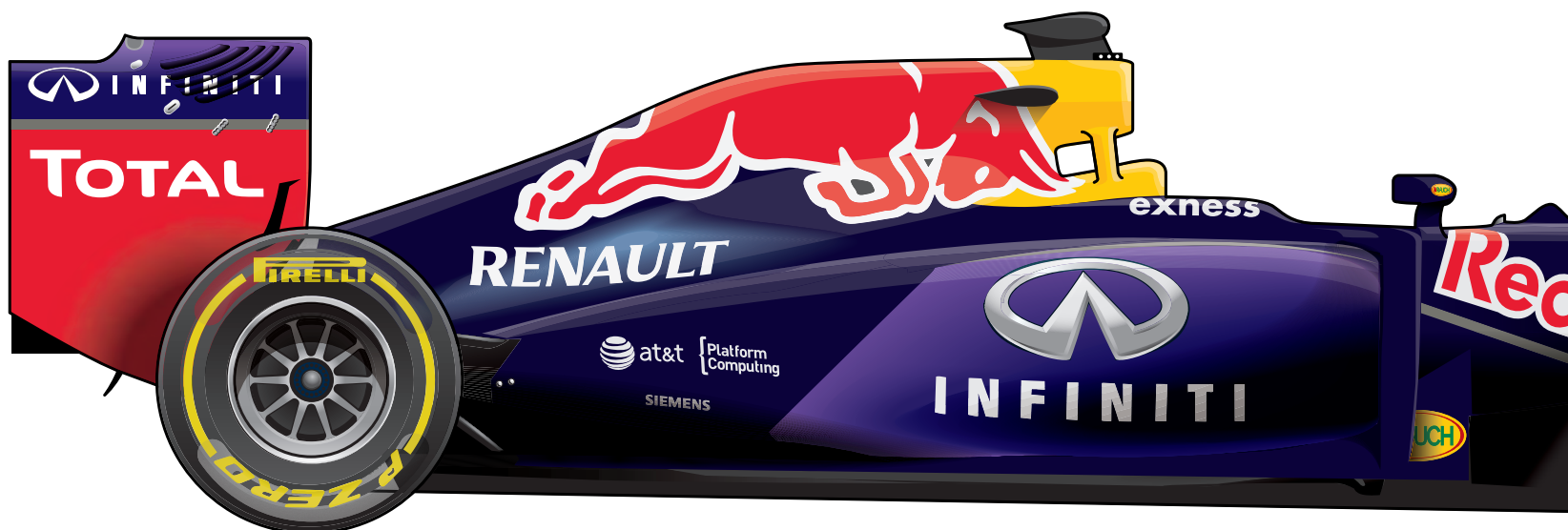

Red Bull-Renault RB11 ... Championship position 4th ... Best finish 2nd ... Podiums 3 ...

This was a trying season for the former world champion team, which lost ground competitively to Mercedes, Ferrari and Williams, fell out very publicly with its engine supplier Renault, and finished the campaign seeking reconciliation with the French manufacturer as alternative options failed to materialise.

Red Bull finished second to Mercedes in 2014, despite a power shortfall in Renault's V6 hybrid-turbo engine, and the expectation was that the Viry dynos would find enough extra power over the winter to allow aerodynamic

wizardry and a slick race team to make up the difference.

But things didn't work out nearly as well as hoped. Renault's development power unit was difficult to exploit during pre-season testing, and had to be detuned to allow Red Bull and sister squad Toro Rosso to rack up much-needed mileage.

Problems with exploding pistons in the race-spec engine readied for Melbourne and the other early-season flyaway races then put both teams on the back foot in terms of unscheduled changes and subsequent grid penalties.

The lack of reliable running early on hampered Toro Rosso graduate

Daniil Kvyat in his quest to adjust to a new environment, while three-time grand prix winner (and last year's standout driver) Daniel Ricciardo grew frustrated upon realising he would not be able to challenge for the championship, or even repeat his 2014 heroics.

But the RB11 was also a difficult chassis to unlock initially. July's British Grand Prix provided the breakthrough. Red Bull introduced an aerodynamic update that finally gave the drivers confidence in the platform under them. It had worked hard to recover downforce lost to the FIA's stringent new nose regulations, but the drivers struggled to make use of it. A

rethink following May's Spanish GP and post-race test allowed the design team to get back on track.

"There were a few areas we were fighting from the outset with the car," admits engineering chief Paul Monaghan. "We took some different parts to the Spanish GP and by the close of the weekend and subsequent test we'd learned an awful lot – some good, some bad. We changed tack a little bit, and it started to come together."

Renault was unable to catch up lost ground in the development race, failing to introduce an in-season performance upgrade until October's US GP, by which time Mercedes had spent all its tokens and updated its engine twice, Honda thrice, while Ferrari had also introduced two major combustion changes with tokens to spare.

Red Bull's best chances to shine therefore came on the low-speed circuits – Monaco, Hungary and Singapore – which the team also targeted in terms of car set-up and design. At each of these races the RB11 was fast enough to compete with Ferrari and latterly Mercedes too, the highlights being a double podium behind Sebastian Vettel in Hungary, and a superb second place for Ricciardo in Singapore.

But for a team that's used to winning races and titles, three



The sparks didn't fly for RBR in its worst season since 2008

“For a team used to winning, fourth in the constructors’ points was not satisfactory”

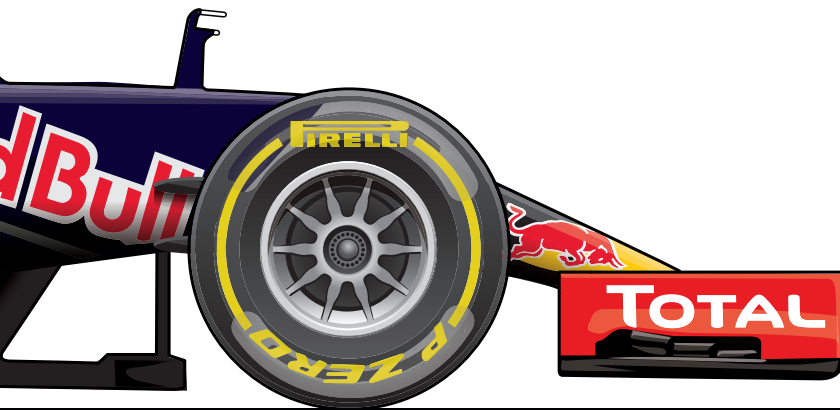

DANIL KVIAT

7th

Championship position

8th

Starts	18	Starts	19
Best finish	2nd	Best finish	2nd
Best grid position	4th	Best grid position	2nd
Fastest laps	0	Fastest laps	3
Points	95	Points	92



DANIEL RICCIARDO

Best grid position 2nd ... Fastest laps 3 ... Points 187



Renault engine struggles were the big story of the season

The verdict

This was a year of soul searching for Red Bull, which spent the first half of the season berating Renault and then seemed surprised Mercedes and Ferrari weren't queuing up to supply the team, forcing it to stick with Renault for 2016.

A portion of humble pie might be necessary before Red Bull can get a new works power-unit deal.

Renault deserved some criticism at the start of the season, but Red Bull's car was hardly perfect and the performance of Toro Rosso showed it up on several occasions. Red Bull blamed this on the engine characteristics not suiting its car well. More power, as long as it's



delivered correctly, will suit any car, but the key at any time is to optimise your package around what you have.

Yes, progress was made during the season. But the numbers show it was nothing remarkable.

GARY ANDERSON

podiums and a distant fourth place in the constructors' championship was nowhere near satisfactory.

The frustration felt by team owner Dietrich Mateschitz led to a concerted effort to secure a supply of customer Mercedes power units for 2016. When Mercedes' board rejected that, and Ferrari also said no, moves by Red Bull to terminate its Renault contract a year early looked somewhat hasty.

There was talk, of course, but no concrete attempts were made to become works partners in the mould of McLaren and Honda, despite suggestions early in the

season (from both sides) that this needed to happen to drive the Red Bull/Renault alliance back to the front of the grid.

Renault instead decided to reacquire Lotus and become a works entity again. In spite of all the public arguments, and attempts to part ways, it also looks like Red Bull will remain a Renault customer for another season, however the engines are officially badged.

This was a difficult year for both organisations, and not one that will be easily forgotten, but now is the time to knuckle down and come out swinging again in 2016. ❄

Race by race car pace

Performance relative to the fastest single lap of each weekend (%)

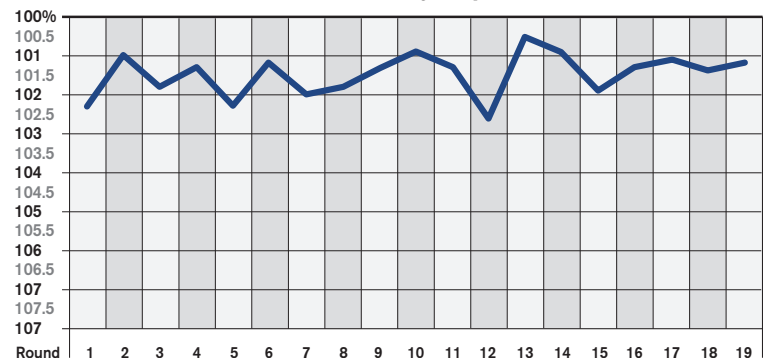



DUNBAR/LAT

The Renault slump

After last year's troubles, Renault was expected to do better in 2015. But it proved to be

It all started reasonably well. Renault completed this year's winter testing in a much better place than 12 months earlier, when poor reliability blighted its preparations.

The French manufacturer deliberately held back performance in the opening two pre-season tests in order to prove the reliability of its new power unit. With that target successfully hit, it ramped up performance for the final test. The early signs were that the new engine was more powerful.

But the upgrades had caused driveability problems and it was clear there was no quick fix.

Renault had aimed to slash the gap to Mercedes by half a second. The reality was it hadn't been closed at all. Worse still, Ferrari had had a strong winter and jumped ahead.

Renault had made fundamental changes over the winter, following a disappointing season by its standards that yielded just three wins with Red Bull. The internal-combustion engine (ICE) had a new combustion chamber, a new exhaust-system concept was introduced and the compressor's efficiency was improved.

But those changes created problems that Renault hadn't anticipated and, as would become a

theme, took too long to fix.

"We chose a way to run our engine with different hardware, which was not the best decision we ever made," admits Renault head of trackside operations Remi Taffin. "But we eventually made it work, which is a good thing because there was some performance out of it. We also had a piston problem from the beginning of the year, which we did not anticipate. This is quite a big part to change the design of, so I think that was the key."

But rather than curing the driveability problem in time for the first race, troubles persisted. It wasn't until the start of the

European season when Renault finally got on top of it.

In the interim, Red Bull found itself compromising its set-up. "It took too long to get it sorted," says Taffin. "It should have been done for race one but it was done for race five. We didn't pick up the problem with driveability around 8000-9000 revs. We thought we could work around that without much hardware modification but it proved to be more difficult than that. So maybe we have been a bit too optimistic in the resolution of this problem."

That admission is key to Renault's struggles. Its belief that

“We chose different hardware – not the best decision we ever made”

Renault engine problems were a familiar sight in 2015; podiums weren't

explained

a big step backwards. By Lawrence Barretto

it could solve a problem rather than admit it had made a mistake and choosing an alternative has really hurt. As the problems built, staff started to doubt themselves.

“When you do hit troubles, you become more reluctant to change things but you then learn from that and you put some more detailed processes in place and so on,” says Taffin. “That adds time.”

With reliability the focus, thoughts of improving power were put on the backburner. And the longer it took – and the more failures it had – not only did costs spiral, but Renault continued to lose ground to rivals. It was a spiral

from which it couldn't escape.

“With good reliability, you have fewer problems on track, you score more points, you have less problems on the dynos, you run your dynos more often and then you develop quicker,” says Taffin. “We used on average six or seven engines for each driver, compared to four normally. That cost us more money – money which should have been going into development.”

As Renault scrambled to find answers, its original token plan went out of the window. Planning to use them in two or three batches – as its rivals had done – Renault >>



Q&A

DANIEL RICCIARDO
RED BULL DRIVER



After three victories in 2014, Ricciardo managed just two podiums this year thanks to Renault's problems

How would you rate the progress of Renault with its engine during this season?

We have had some races that surprised us by being able to keep the Williams and Ferrari behind us for so long. There are races where you can say the car and the package has come a long way but then you get to Austin, and when it dried up we were wide open down the back straight. We were bleeding a lot. It has been up and down and with the engine; it has been hard to quantify what we have gained.

What was the driveability like early on and how has it improved?

I would say the first five or six races, it was quite a big problem for us. It has got a lot better, but I think you also get used to something, you get used to dealing with a few things. So maybe if this is a step forward in driveability, it will feel like two steps. Hopefully that's an area we can gain on.

How much did you have to compromise your set-up mid-season to counter the lack of power from the engine?

A lot of the stuff came back to compromising for loss of power. In a debrief, we'd complain the car was sliding and we couldn't get it to turn in here or there, and we were just not able to run as much downforce with the loss of power. When you have these issues it hurts your feeling on traction and it's easier to break into wheelspin, so you have to look at setting up the car differently to mask these problems.

What do you make of Renault's latest update?

Whatever they've done they need to steer in the other direction from that and try something, because it obviously hasn't worked. It's not like this is the first year anymore. It's pretty much two years of development and understanding and it's not much different to what we had last year.



Both Red Bull drivers made the podium in Hungary... a rare high

ended up waiting to use them in one go. Only there was another delay. Having applied to use 11 of its 12 tokens, it only used seven – all focused on the ICE, which it introduced two races late in Brazil, and only on Ricciardo's car. Ricciardo was particularly scathing of the update, suggesting the engine was no better than the old one. That was a little harsh as there was some improvement, perhaps a tenth, but it was hardly what Red Bull had hoped for. The rest of the upgrade, using four tokens on the turbocharger, was delayed. Once again Renault had missed its targets, possibly because it was so keen to get everything right rather than risk more failure on the track.

The once-so-successful relationship between Red Bull and Renault gradually disintegrated over the course of the season, with Red Bull publicly criticising its engine supplier, and Renault in turn growing more annoyed. It started focusing on its own plans, which involved it either pulling out of F1, staying on as a supplier or making Lotus its works team. Red Bull, meanwhile, told Renault it wished to terminate its contract, before reopening talks about a deal for next year when it became clear it couldn't find power elsewhere. "Sometimes you wonder if they only read what's in the media," admits Taffin of the impact of the fractious relationship on staff. "Maybe it is eating a bit into morale, but we are all professional and want to be the best so it should not affect our work."

The two parties gradually drew further apart rather than getting closer, but Taffin doesn't see it that way. "I don't know if we could have worked any closer; I think we're already close," he says. "It's fair



Early on, Toro Rosso got more out of the Renault than Red Bull

to say when you are a chassis plus engine team rather than in a customer relationship, sometimes you don't look at the overall situation in the same way. So maybe you could have done it differently. But to be fair, with the rules we had in place, I think we made the best out of it."

In a bid to find a solution, Red Bull and Renault called on Mario Illien and his Ilmor company. Ilmor developed a solution while Renault simultaneously followed the path it felt was right. When the two plans were compared, while feeling that Illien provided some good ideas, Renault chose not to take that solution onboard. Its own development only offered one tenth's worth of improvement, around a fifth of what Illien felt Ilmor's iteration could deliver.

TECHNICAL ANALYSIS By Craig Scarborough

HOW RENAULT STARTED BEHIND... AND THEN FELL FURTHER BACK IN 2015

Renault struggled with power and poor reliability in the first year of the 1.6-litre V6 era, so it was a surprise it did not use more of its 32 winter development tokens on its 2015-spec engine. It used just 20 tokens on the launch spec and its layout differed little from the 2014 version.

The turbo was rear-mounted while the turbine and compressor both closely coupled and linked to the MGU-H, which sits ahead in the 'V' of the engine. The MGU-K was on the left flank of the engine

with the power electronics sat low down in the sidepods below the radiators.

The upgrades saw the return of driveability issues and unreliability from a piston-related problem, and it soon became clear Renault had not made a jump in power output over the winter. The reported deficit to Mercedes and Ferrari of 50bhp only increased as its rivals made progress. This deficit remained an issue as the season commenced and the team sought to resolve the problems.

Renault's power issues were ICE-related, not ERS. The ERS is able to deliver the full 160bhp of electric power for 33 seconds from ERS-K and through the rest of the lap from the ERS-H, which harvests energy from the turbo.

A sign of the power unit's problems is shown in the size of the cooling package, which is far larger than its rivals'. The turbo intercoolers are so large they are split into two, one in each sidepod. The power unit is also sensitive to

heat and this creates problems with knock in the combustion chamber, which limits engine power.

Progress has been made with fuel development from Total, which has helped increase power without resorting to penalties or token spend. Meanwhile, the update which made its debut with Ricciardo in Brazil featured Renault's combustion upgrade, which was aimed at increasing power, but more work is required to get the most out of it.



“I don’t know if we could have worked any closer with Red Bull”

“We have been working on a concept which has been run by Ilmor on other engines,” says Taffin. “We learned from that, but we did not take this in our engine at the minute. We now stop our activities with them, the project has delivered what it was supposed to in terms of results. We still have some projects internally where we look at their different concepts.”

But why turn down something that shows such potential? “The reasoning was performance,” says

Taffin. “We always looked at the performance, not only at race five or seven but what you would get later, in 2016.”

Renault admits it made mistakes and that it underestimated the ICE, with too much focus on the ERS. It also admits the token system hasn’t been its problem. “We had enough tokens last winter and we had enough through the season,” says Taffin. Renault simply didn’t take advantage. It now seems to be on top of the ICE

problems, albeit 12 months later.

To be fair to Renault, while it has barely closed the gap to its rivals, it hasn’t really lost ground either. “We know the gap,” says Taffin. “When you go to Monaco/Budapest, it’s more like four or five tenths and when you go to Monza it’s nine tenths or a second. If we hit our targets, we will have a competitive engine and be able to fight for wins again at every race.” Also, Red Bull’s problems haven’t just been about the engine. Ricciardo vented his frustration in Canada with the chassis, suggesting the developments the team were bringing weren’t working, and it wasn’t until Silverstone that Red

Bull was on top of it. Positively for Renault, it seems to

be on top of its reliability problems too. That’s had an impact on track, with Red Bull’s results improving towards the end of the season.

“With performance, we need to find our way,” says Taffin. “When you change the way you think, you have to go through a lot of things to make sure you have it right. If you really want to make it happen, you do it normally for a year, then progress for the next year.”

This has been a tough year for Renault. It has spent most of its time playing catch-up and been hurt by the criticism from its partner Red Bull. But there is a glimmer of hope. It believes it has identified the weak points. The challenge is now to rectify those and quickly, something that has proved to be its Achilles’ heel this term. ❧

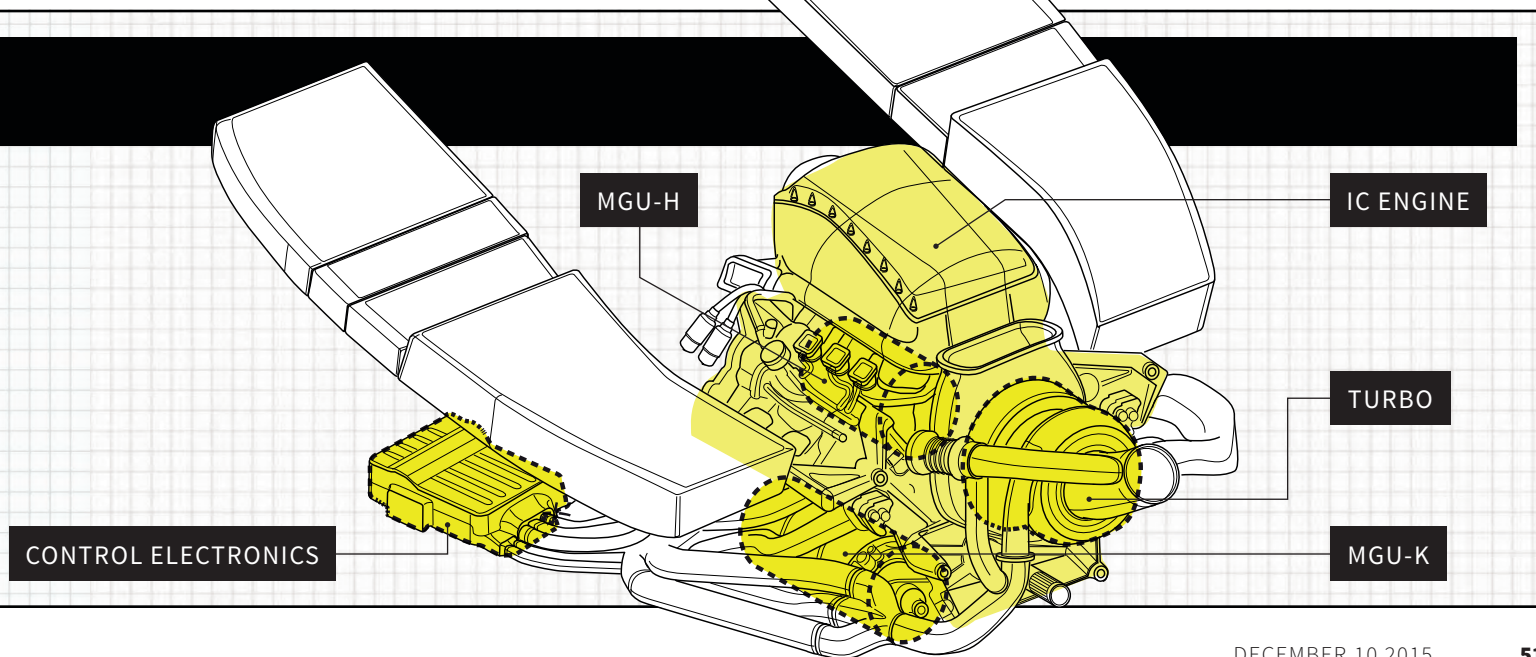

Force India

The ex-Jordan team climbed yet another place in the championship this year, a remarkable feat given how long it had to wait to introduce its B-spec machine

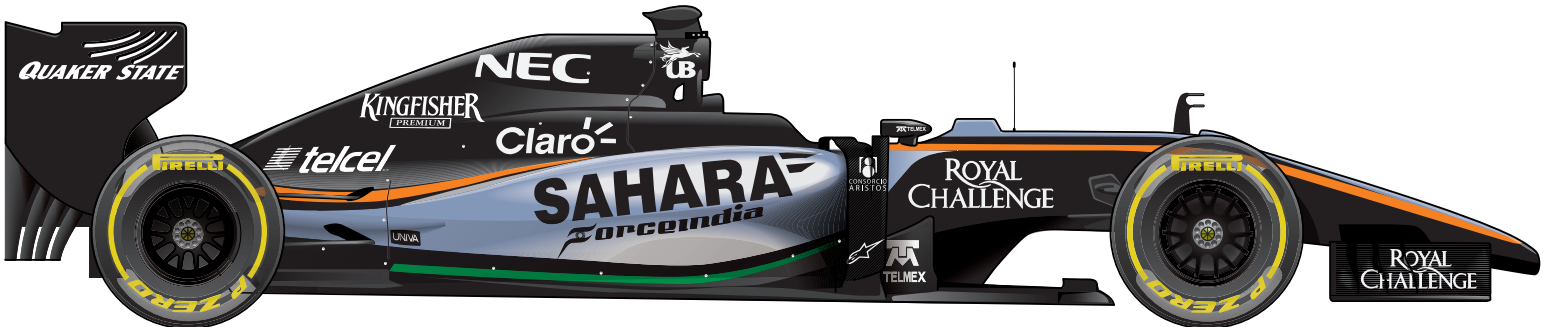

Force India-Mercedes VJM08 ... Championship position 5th ... Best finish 3rd ... Points 136

Force India began the season short of cash and unable to ready its new car in time for the start of pre-season testing, but remarkably ended the campaign with its best finish in the constructors' championship since Vijay Mallya took over the former Jordan operation in 2008.

Key to this transformation was the gradual introduction of a 'B-spec' update to the VJM08, including a unique 'nostril nose', which transformed it from marginal points contender to best of the midfield cars.

The performance of the team over the second part of the season justified the decision to abandon its outdated windtunnel for a sole programme in Toyota's facility in Cologne. The team knew it would take a hit in the early part of the year, but from Austria onwards the VJM08 was a stronger proposition.

"VJM08 was essentially VJM07 with the new nose and hydraulic

actuation for the suspension," says technical director Andrew Green, who reckoned the VJM08 was actually slower than its predecessor initially, thanks to the team getting caught out by the new nose regulations robbing downforce. "VJM08B was an all-new car developed in the Toyota windtunnel," he adds.

Suspension and wing failures in Hungary aside, the latter part of the campaign was superb, the highlights being an unlikely podium finish for Sergio Perez in Russia, and qualifying just over a tenth behind Ferrari in Abu Dhabi.

It's true that the struggles of McLaren (which won a close fight for fifth place in the title race last season) presented an open goal this year, but the Silverstone-based squad took its chance with aplomb.

"We set ourselves targets to beat teams we shouldn't beat and make them look a bit silly," says Green. "When you do, it sends a shiver down your back."

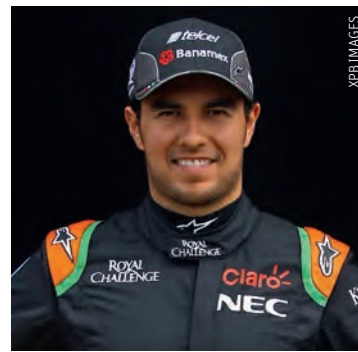

SERGIO PEREZ

9th

Starts	19
Best finish	3rd
Best grid position	4th
Fastest laps	0
Points	78



NICO HULKENBERG

10th

Starts	18
Best finish	6th
Best grid position	5th
Fastest laps	0
Points	58



Force India's B-spec car brought consistent results

Race by race car pace

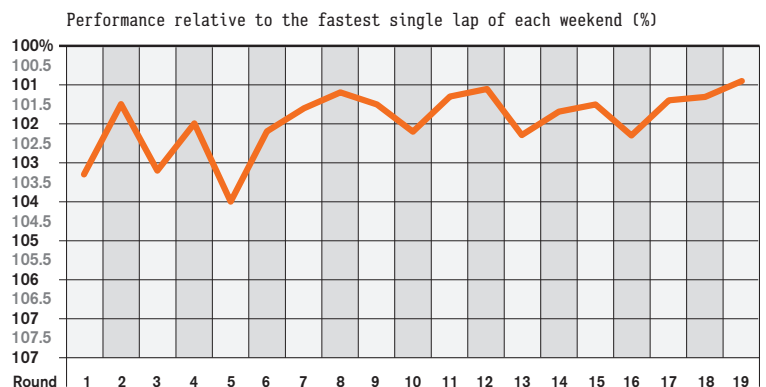

Lotus

Money troubles, a long-running saga about the Renault takeover and occasions when the team couldn't get to the track... yet somehow Enstone got good results

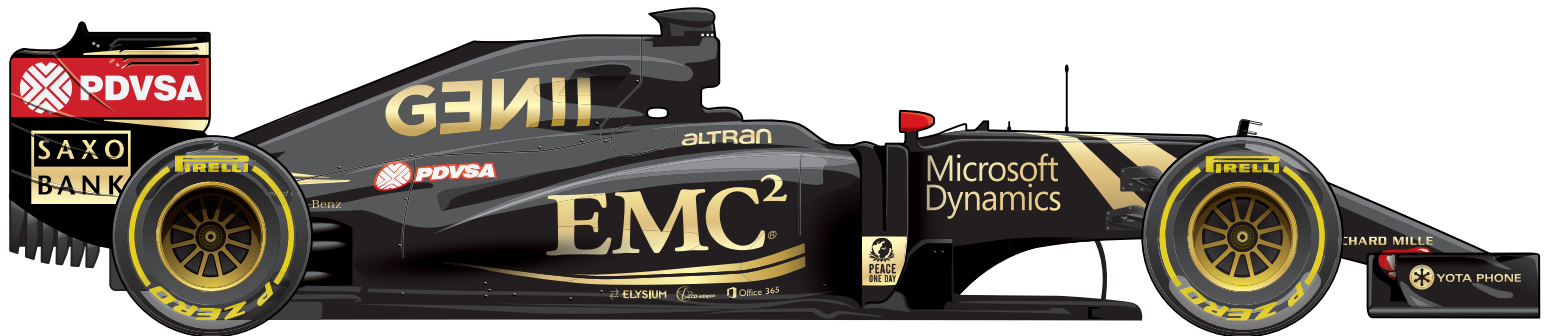

Lotus-Renault E23 ... Championship position 6th ... Best finish 3rd ... Points 78

Lotus bounced back from the disastrous campaign of 2014 to produce a tidy car that, with Mercedes customer power in the back, was a regular lower-points contender.

Another of the midfield teams to be badly affected by cashflow and supplier problems (partly a legacy of the disasters that befell Caterham and Marussia last year, which meant reduced credit with jittery sub-contractors), Lotus arrived late to pre-season testing, and lacked the budget to do any meaningful development.

This meant the E23 lacked downforce, and was weak on slow-speed circuits such as those in Monaco, Hungary and Singapore.

Nevertheless it regularly qualified inside the top 10 in the hands of Romain Grosjean, who – better engine aside – also delighted in the fact that Enstone at least delivered him a more stable platform from which to express his

gifts this year. This was mainly due to ditching the asymmetrical ‘twin-tusk’ nose of the 2014 car, which stalled the diffuser in yaw.

Pre-season expectations of challenging Williams proved far fetched, but that aim would have been much more realistic had the management funded a proper development programme instead of holding out for a sale of the team back to former owner Renault.

Lotus reckoned it would have beaten Force India to fifth without that freeze, estimating its rival's upgrade made the VJM08 0.15s faster than the E23, while Lotus sat on 0.4s of unused potential.

With the Renault takeover as good as done at the time of writing, the team should be able to move forward in 2016.

This has proved time and again that it's a tidy race team that just lacks money. But even with fresh investment from Renault, next season will be tough without the advantage of Mercedes engines. ❄

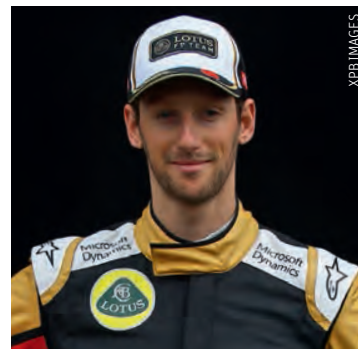

ROMAIN GROSJEAN

11th

Championship position

Starts	19
Best finish	3rd
Best grid position	5th
Fastest laps	0
Points	51

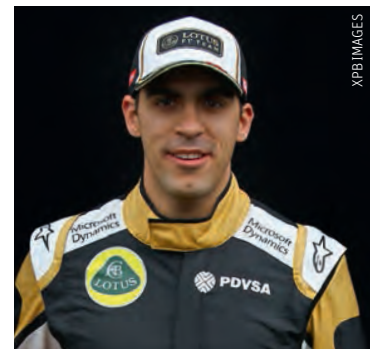

PASTOR MALDONADO

14th

Starts	19
Best finish	7th
Best grid position	6th
Fastest laps	0
Points	27



Maldonado finished in the points six times, but there were errors

Race by race car pace

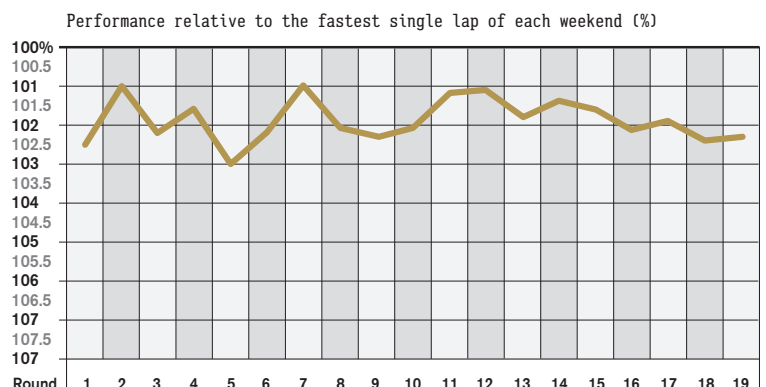

Toro Rosso

There were moments early in the season when Red Bull's B-team showed up the main squad, and its dynamic driver line-up was one of the stories of the year



Toro Rosso-Renault STR10 ... Championship position 7th ... Best finish 4th ... Points 67

A pre-season target of finishing fifth in the constructors' championship seemed far-fetched when Red Bull's junior team unveiled its 2015 challenger ahead of the first test at Jerez. But team principal Franz Tost was convinced this was the best F1 car his team had ever produced and, although the ultimate result fell some way short, performance-wise it's difficult to disagree with that sentiment.

Technical director James Key and his crew did an excellent job, and Max Verstappen reckoned the STR10 was second only to Mercedes in terms of chassis performance at high speed. Rivals thought the car was one of the four best in terms of aerodynamics.

The letdown for Toro Rosso was the performance and reliability of the Renault engine, which it spent less time complaining about than its 'parent' team, but arguably suffered more for. Still, overtures

to Ferrari for year-old engines from next season tell their own story...

The rookie drivers performed very well, but were too often let down by poor reliability. There were naturally some mistakes too – Verstappen clattered spectacularly into Romain Grosjean in Monaco and went off on his own at Silverstone, and Sainz crashed heavily at Sochi and Austin, while both cars should have beaten the Lotus in Japan but finished behind after scruffy weekends.

It was a similar story in Mexico, though with the added headache of managing brake and engine temperatures. Braking efficiency in particular is an area where Toro Rosso still needs to improve.

Encouragingly, the operational errors that cost the team so dearly in 2014 were largely eradicated, but the end result is basically the same – seventh in the standings. A missed opportunity certainly, given it finished just 11 points behind Lotus. ❄️



CARLOS SAINZ JR

15th

Championship position

Starts	19	Starts	19
Best finish	7th	Best finish	4th
Best grid position	5th	Best grid position	6th
Fastest laps	0	Fastest laps	0
Points	18	Points	49



MAX VERSTAPPEN

12th

Race by race car pace

Performance relative to the fastest single lap of each weekend (%)

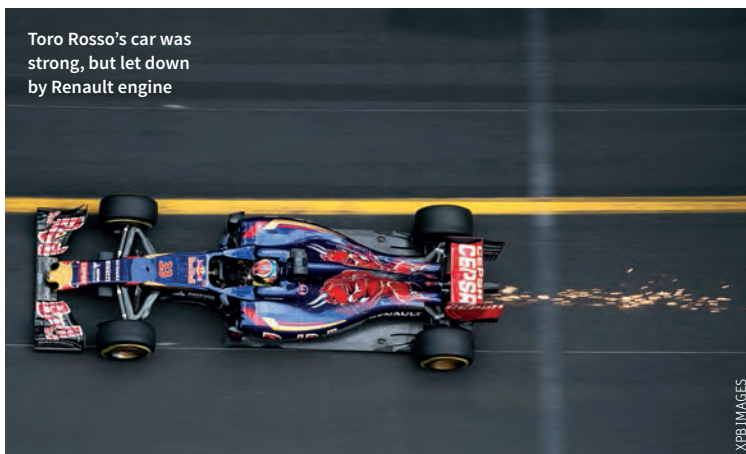
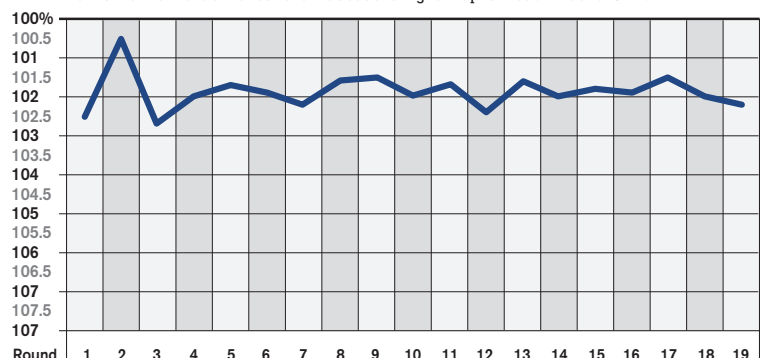

Sauber

The Swiss team recovered from last season's pointless campaign with a solid year, scoring regularly despite struggling to match the development pace



Sauber-Ferrari C34 ... Championship position 8th ... Best finish 5th ... Points 36

After a diabolical 2014, which ended with zero points scored for the first time since the team entered the world championship in 1993, surely the only way was up for Sauber.

That's exactly how it turned out, as it amassed 36 points and climbed to eighth in the championship.

It got the monkey off its back straight away, at least once the contractual dispute with ex-reserve driver Giedo van der Garde (which grounded its cars temporarily in Australia) was out of the way.

Brazilian rookie Felipe Nasr recorded a sensational fifth-place finish on his F1 debut to ensure there would be no statistical repeat of Sauber's annus horribilis.

The main driving force behind this improvement came from the engine department in Maranello. As a Ferrari customer, Sauber benefited from the substantial steps made for 2015 in terms of power, efficiency, driveability,

energy recovery and deployment.

But the C34 was also a much better chassis than its predecessor, largely addressing the braking and corner-entry instability that made the C33 such an evil car for Adrian Sutil and Esteban Gutierrez in 2014. This was partly down to improvements in aerodynamics, aided by Pirelli beefing up the construction of its rear tyres.

Traction and ride remain key weaknesses, though, exposed on bumpy circuits with aggressive kerbs. The team reckons this is inherent to the design of the car, rather than something correctable through set-up adjustments.

In-season development also remained limited, and the C34 slipped to the tail of the midfield as the season progressed.

Sauber's strategy relied largely on having better reliability than its nearest rivals. And it worked, allowing the team to score enough points to put the disaster of last year well and truly behind it. ❧



FELIPE NASR

13th

Starts **18**
Best finish **5th**
Best grid position **8th**
Fastest laps **0**
Points **27**

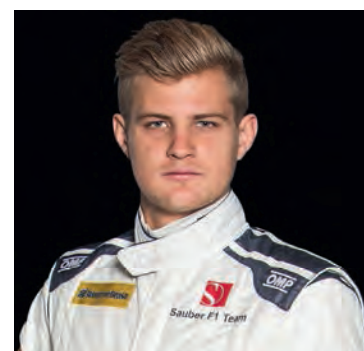

MARCUS ERICSSON

18th

Starts **19**
Best finish **8th**
Best grid position **9th**
Fastest laps **0**
Points **9**

13th ————— Championship position ————— 18th

Race by race car pace

Performance relative to the fastest single lap of each weekend (%)

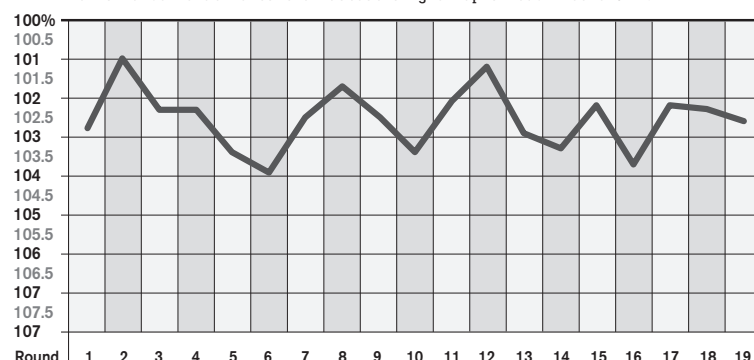

Nasr delivered Sauber's best results: a fifth and a sixth

McLaren

Expectations were sky-high, but results were terrible as the renewed McLaren-Honda partnership struggled badly in its first season since 1992

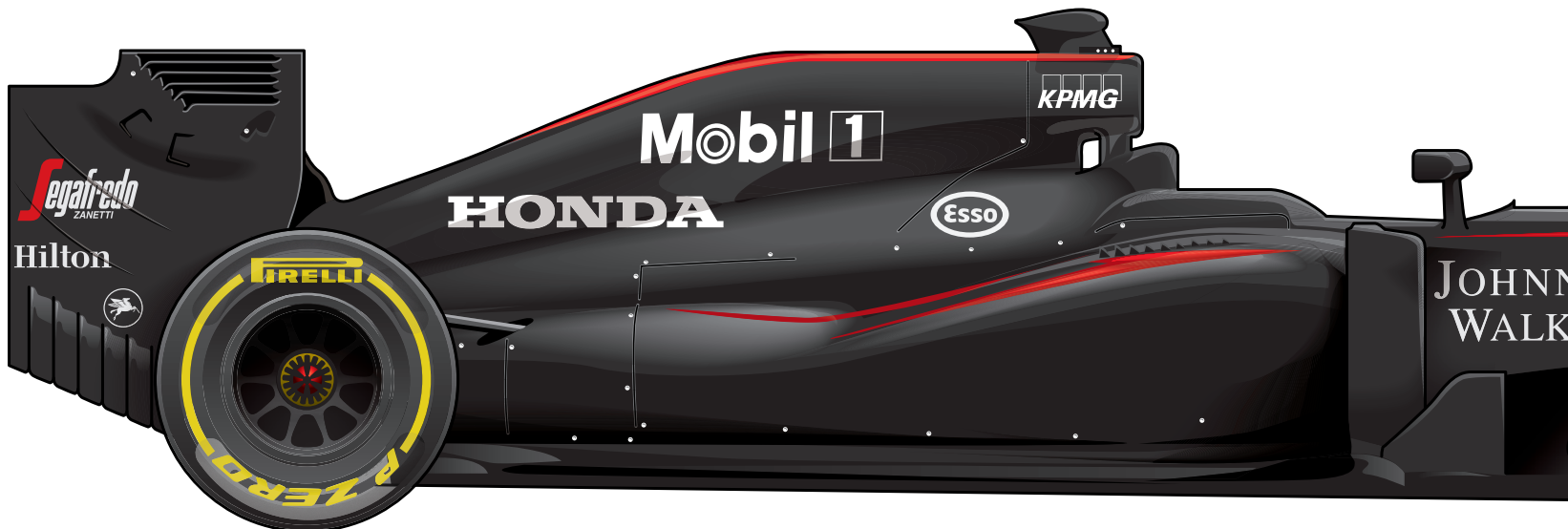

McLaren-Honda MP4-30 ... Championship position 9th ... Best finish 5th ... Podiums 0 ...

Oh where to begin with McLaren-Honda? Expectations were always going to be unrealistically high when this famous alliance reformed, thanks to a shared history that helped make Ayrton Senna a household name, and which dominated Formula 1 briefly in the late 1980s and early '90s. Results were never likely to be outstanding, given Honda's late arrival to the V6 hybrid-turbo party in comparison to rivals Mercedes, Ferrari and Renault, but were still diabolical for a team of this stature and resource. A McLaren never made the top 10 in

qualifying, and only scored points in five of the 19 grands prix held. Ultimately, McLaren-Honda should not be judged by its achievements (or lack of them) this season. The move to ditch a customer supply of currently the best engine in Formula 1 came from a firm belief that it would be impossible for McLaren to win the world championship again without becoming a works team once more, and Honda provides that status. This is about taking several steps back to make one giant leap. But on current evidence it's not clear whether Honda has the wherewithal to power that leap. Its first year back in F1 was a

catalogue of woes concerning engine reliability, power output and the inefficiencies of its ERS. But there were also serious questions raised over its competency and speed of reaction. The ERS weakness of the Honda power unit, caused by a weedy and inefficient turbocharger, turbine, compressor and MGU-H, was brutally exposed on high-speed tracks, particularly Spa, Monza and Sochi, and also in the high altitude of Mexico City, where Jenson Button raced to a "painful" 14th, beating only the Manor Marussias. Mounting ERS components within the V-bank of the engine, in order to help McLaren realise its

'size-zero' aerodynamic packaging philosophy at the rear of the MP4-30, played a large role in this pain, but Honda was complicit in this path, so must work better within the space constraints by producing better and more efficient parts. "We are looking to change things – we'd be stupid not to," says McLaren technical director Tim Goss. "I don't think it's going to have a marked effect on tightness of the bodywork. We can intelligently move things around to achieve our aims without compromising aero and packaging." Energy-recovery problems aside, the good news is that Honda was able to make genuine gains with its internal-combustion engine, and there were encouraging signs coming from the chassis department too after several seasons of underperformance. The restructuring that has taken place under racing director Eric Boullier is apparently paying off, while Peter Prodromou's Red Bull-inspired influence is guiding McLaren along more fruitful aerodynamic development paths. "Peter is a great aerodynamicist," adds Goss. "We hired him for his knowledge, ideas and philosophy. Some of the things we were pursuing fitted very neatly with Peter's ideas. In other places he's



“We have no idea how good the car was because of the engine performance”

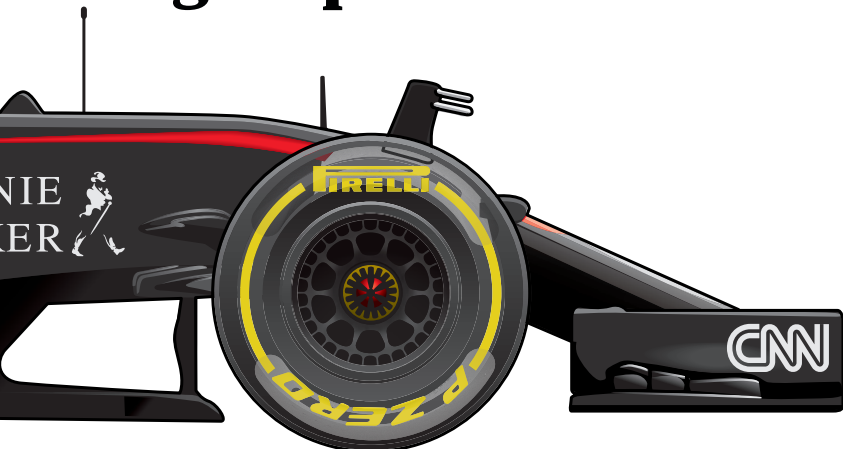

JENSON BUTTON



FERNANDO ALONSO



KEVIN MAGNUSSEN

Championship position



Starts	18	Starts	18	Starts	0
Best finish	6th	Best finish	5th	Best finish	N/A
Best grid	10th	Best grid	9th	Best grid	17th
Fastest laps	0	Fastest laps	0	Fastest laps	0
Points	16	Points	11	Points	0

Best grid position 9th ... Fastest Laps 0 ... Points 27

The verdict

For all the noise generated, the numbers show McLaren-Honda didn't make any meaningful progress during 2015. At the first race it was particularly abysmal, but when you compare the race two-to-four average with the end of the season, there's little difference.

Yes, a lot of the blame lies with Honda and as we have heard many times it's a long-term partnership, but sometimes alliances turn very short-term if they don't get successful quickly.

At the start of the season I don't think the McLaren was as good a car as it should have been. It also tied Honda's hands by designing a car that was



totally committed to a very compact 'size-zero' cooling package.

This didn't allow Honda to explore the avenues it might have wanted to try, but it never really showed it knew which direction it wanted to go in.

GARY ANDERSON

Race by race car pace

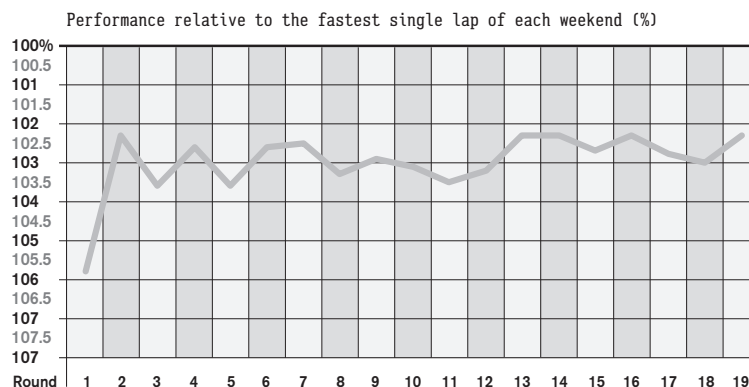

Button bagged McLaren's first points of the year in Monaco

brought new things. It wasn't necessarily a radical shift in emphasis. He's blended very nicely with the team."

But we have no idea how good the MP4-30 really was, because its high-speed performance was so compromised by its engine's lack of power. McLaren was arguably better than Williams and Ferrari aerodynamically by the end of the season, but deficient in ride quality, and way behind all bar the Manor Marussias in terms of engine performance...

Overall, this was comfortably the ninth-best package over the year,

highlights being an opportunist fifth place for Fernando Alonso in Hungary and a strong drive by Button to sixth in the US GP.

Although it improved through the season, this car was not ultimately worthy of the talents of two world champion drivers with more race starts, wins, podiums and points amassed between them than any other pairing on the grid.

If McLaren-Honda is ever to deliver on its aim of being world champion again, next season must be much, much better. This year was simply not good enough for a team of this might and repute. ❄️



Lack of reliability had a knock-on effect on chassis development



XPB IMAGES

Honda's failure

What was always going to be a hard year turned into a shocker. **Ben Anderson** explains what went wrong at McLaren

Unquestionably, 2015 was a terrible season for McLaren. For a team of its status, resources and technical might – and given the fact that it was running two world champion drivers – finishing only ninth in the world championship was not good enough.

Everyone at McLaren knew that the first year of its renewed works-engine partnership with Honda would be tough, but improvements were expected to come fast enough at least for it to match its fifth place in the 2014 constructors' championship.

As it was, McLaren-Honda fell well short of that. No wins, no podiums, just 27 points between both drivers; and not once did one of the cars qualify inside the top 10 for a grand prix. McLaren's worst season ever? Arguably, yes. It finished ninth in 1980 too, but that year at least tied on points with the two teams above it...

But however much F1 fans might have hoped for a glorious comeback, Honda's return to F1 was never really about 2015. This is about 'playing the long game'; taking some serious pain

in the short term in order to reap the long-term benefit of world championship success.

Objectively speaking, McLaren ditched a customer supply of the best engine in F1 (the Mercedes) in order to use comfortably the worst on an exclusive basis. But the team had grown frustrated by customer status, particularly with regard to the fact that it has a technical tie-up with fuel company Mobil, while the Mercedes V6 is optimised around Petronas lubricants.

McLaren felt it couldn't compete with the might of the works Mercedes team as a customer, so decided it had to become a works team to fulfil its aspirations of fighting for more world titles.

That's where Honda came in. Trouble is, Honda faced the dual challenge of a late start with the new technology in F1 compared to its rivals, and the need to build up an F1 operation from scratch and relearn how the game works. All this having been out of the category completely since it pulled the plug on its last full works team in 2008, and all the while attempting to innovate in order to outwit the opposition.

The scale of the mountain >>>



Alonso has had to be patient in 2015, but how long will he wait?

Alonso and McLaren reunited

When Fernando Alonso fell out with McLaren at the end of 2007 and left to rejoin Renault, most people thought he would never return.

But return he did, lured away from Ferrari by Honda's millions and the promise that McLaren is putting in place plans to topple the mighty Mercedes juggernaut, which would give Alonso the chance to win the third world title he so desperately craves before he retires.

Things started badly, with Alonso suffering concussion during the second pre-season test at Barcelona, where he crashed exiting Turn 3 in circumstances that are still not fully understood.

This caused him to skip the first race in Australia, but he returned for round two in Malaysia showing no ill effects, and continued to show no real ill will towards his 'new' team, despite the lack of results.

True, there were occasional radio outbursts about Honda's "GP2 engine" and rumours he may take a sabbatical in 2016 while McLaren-Honda sorts itself out, and Alonso admitted he drove in "economy mode" this year because of the lack of competitiveness of the package.

But, in terms of working with the McLaren team again, things

couldn't have gone much better.

"The team is much more open now and much more international," he says. "In 2007 it had been the same people for many years. It was a little bit different. The team now is very happy and relaxed. Despite the results we are very united, and the team is very positive."

According to McLaren racing director Eric Boullier, some of the intrinsic difficulties of 2007 that led to a breakdown in relations between team and driver have now dissipated.

"I think the problem was mainly a product of the house - Lewis was naturally the favourite of the home, because he is British, he grew up in McLaren, and you can't do anything against this," Boullier explains. "The entourage of Fernando should have warned him about this."

"The difference [now] is that he's eight years older, and I think McLaren is maybe listening to him a little bit more. But I don't want to go into this, because it would not be fair to criticise the past."

Things may well be very different now, but chances are the end result will be similar if McLaren-Honda cannot get its competitive act together quickly. Alonso is 34 now, so time is of the essence.

Honda had to climb was apparent from the first test of its V6 hybrid turbo in Abu Dhabi last November. McLaren junior Stoffel Vandoorne completed just five laps in two days as the engine suffered persistent electrical problems while running in the back of a McLaren test hack.

There was some improvement in pre-season testing this year, but the 'size-zero' MP4-30 (so-called in reference to the particularly tight aerodynamic packaging at the rear of the car) was still woefully unreliable and off the pace...

Here Honda began learning the difficulties of getting the complicated hybrid systems to work correctly. A shaft within the MGU-K component of the Energy Recovery System repeatedly failed, and eventually McLaren had to step in (calling on its experience with KERS under previous rules) to help Honda create a fix.

Honda also struggled to keep the engine cool enough within such tight bodywork. The engines were detuned for the first race in Australia, where Jenson Button finished a twice-lapped 11th and team-mate Kevin Magnussen (standing in for the concussed Fernando Alonso) failed to even start after his engine shut down on the way to the grid.

There were further heat-related retirements in Malaysia (where Alonso returned after his mysterious testing crash), and Button suffered a sequence of electrical-component failures that prevented him participating in qualifying for round four in Bahrain, plus ERS woe that kept him off the grid for the race.

The lack of consistent running in the early portion of the campaign meant the MP4-30 chassis couldn't be developed or set up as quickly as hoped, but by mid-season there was at least significant progress in reliability terms. Some operational errors remained (such as the failure to correctly attach a pipe to Button's engine during practice in Monza), but - the higher-altitude races in Mexico and Brazil aside - the power units stopped going bang or shutting down unexpectedly with such regularity.

Attention therefore turned to the persistent underlying lack of performance. This was exposed brutally at Spa in August, where Honda introduced its 'phase-three' combustion-engine upgrade, but both cars struggled to outpace any rivals except the Manor Marussias.

Honda's chief weakness was a lack of efficiency in some aspects of the ERS, particularly the turbine,

"We expected tension. That's fine as long as it's constructive tension"

Engine failures dogged the team until mid-season





Honda engines were detuned for comeback race in Melbourne

compressor and MGU-H, which together convert waste elements of the combustion process into electrical energy, which can then be used to support the MGU-K in giving a 120kW (160bhp) power boost to the engine via a battery.

This inefficiency was partly due to weaknesses in Honda's components, and partly due to the requirement to reduce the size and capacity of these components for the benefit of the 'size-zero' aerodynamic philosophy. The problems were especially apparent on the long straights of Spa and Monza, where both drivers felt as though they were "sitting ducks", as Button put it, at the end of them.

Honda knows what it needs to do to fix the problem, but questions remain as to whether it has the capability to make those changes in time for the

start of the 2016 campaign. This has caused tensions between the two organisations at times, as McLaren's race team naturally demands faster progress than Honda is able to deliver.

McLaren has also suffered commercial damage from these ongoing poor results believed to be worth roughly £20 million, both in terms of losing prize money for finishing lower in the constructors' table than expected and also sponsorship.

"It was a wake-up call; the toughest ever, I guess," is McLaren racing director Eric Boullier's assessment of 2015. "McLaren was also restructuring itself: a new process, new people, new way of working, new philosophy, huge changes, Honda joining.

"You expect some reliability issues and not to perform as well

as you should, but we were definitely not expecting to be that far off. You always draft a realistic plan and a less-realistic plan, and unfortunately we stuck to the realistic one..."

Nevertheless, there were "bright spots" (Boullier's words) after the 'phase-four' internal combustion engine was introduced during practice for October's Russian GP, then fitted for its race debut in the following event, Austin's US GP.

Having been spun to the back of the field by a touch from Felipe Massa's Williams at the first corner, Alonso raced into the top five (with no small amount of help from some well-timed safety cars, admittedly) and McLaren almost scored a double points finish. More significantly, it raced competitively against other midfield cars, even with a lower specification of engine in the back of Button's car.

The high altitude of the next two races in Mexico and Brazil again exposed McLaren-Honda's deficit in terms of MGU-H and turbo performance (the turbo has to work harder for the engine to produce equivalent power in thinner air), but rivals began to notice how good the MP4-30 looked on the twistier bits of the late-season circuits.

In fact, decent and continuous chassis development was arguably the biggest success of an otherwise terrible season for McLaren-Honda. The restructuring of the aerodynamic department, undertaken since Boullier joined the team at the end of 2013, has got McLaren back on track in terms of conceiving a car that can be improved properly throughout a campaign, which could not be said of the overly-aggressive design of '13 or the overly-conservative effort of last season.

Under the influence of engineering chief Peter Prodromou,

who returned to Woking last September after a stint at Red Bull, McLaren is now pursuing usable and consistent downforce, rather than peak figures. This is making its car more driveable. Both drivers were quite complimentary of the chassis performance and its development come the closing stages of the season.

But McLaren's aim is to build the best car on the grid, not arguably the fourth best (McLaren's own estimate, eliminating the engine from the equation), so the team admits there is still work to do on the chassis side. But the big question remains whether Honda can dig the alliance out of the big ERS-shaped black hole that sucked the life out of McLaren's competitiveness during their first season back together since 1992.

"In the situation we are in now we expected some tensions, but it's fine as long as it was constructive tension," says Boullier. "They [Honda] are quite mature about this. It's true there were differences between both companies, and also there were different approaches. Now we know how it works on both sides.

"We definitely know what we need to do and where we have to be. The path is very clear. Maybe it's a bad for a good. It [the performance] was very, very bad, so hopefully it'll be very, very good in future."

It will need to be much, much better if Alonso and Button are to re-join the big boys at the front of the grid, in which case McLaren's decision to ditch Mercedes customer status for works Honda power will look like a masterstroke.

If not, it could turn out to be the biggest mistake in the team's long and illustrious history. The year 2016 could turn out to be a pivotal one in the timeline of the house that Bruce McLaren built... ❄



Manor

Rising like a phoenix from the ashes, Manor made no impact on the timesheets in 2015. But for it even to have made the grid was one of the great wins of the season

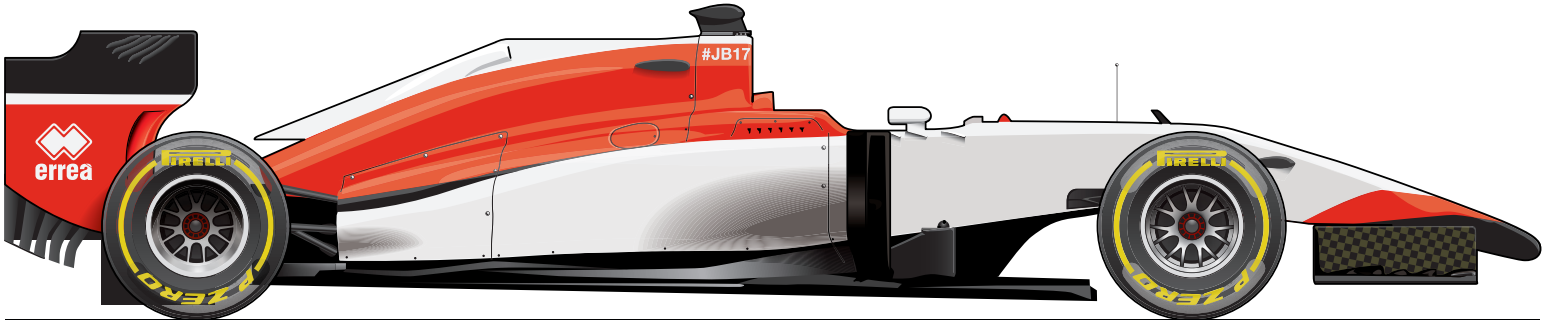

Marussia-Ferrari MR03B ... Championship position 10th ... Best finish 12th ... Points 0

The plucky Marussia team seemed dead and buried at the end of last season, having failed to participate in the last three grands prix. But it rose from the dead to reclaim its place on the grid, which was a monumental feat in itself.

It was saved from administration by a group of investors and relaunched as 'Manor Marussia' on the eve of the new season. Without time to test, or even prepare its 'B-spec' 2014 cars, powered by last year's Ferrari engines, the cars couldn't even run in Australia.

The hastily reassembled squad spent the opening race rebooting wiped software. But by the second round in Malaysia the cars were not only able to turn wheels, but also qualified, even though Will Stevens wasn't able to start.

The car was unsurprisingly difficult to drive and woefully off the pace all year, meaning its drivers were only ever racing each

other while getting lapped. As one rival team boss said, Manor was simply participating in Formula 1 this season, rather than competing.

But that participation was crucial, because Manor/Marussia has now finished inside the top 10 in the constructors' championship for three consecutive campaigns, meaning it qualifies for a greater share of F1's commercial revenues.

Things were looking up when it signed technical partnerships with Mercedes and Williams for 2016. Then came the shock resignations of team principal John Booth, sporting director Graeme Lowdon and new technical director Bob Bell before the close of the campaign.

The true impact of that (and the arrival of ex-McLaren man Dave Ryan as racing director) remains to be seen, but Manor's real fight as an F1 team begins now, as it faces up to the reality of Gene Haas's big-money operation joining the grid, putting its championship position under serious threat. ❄

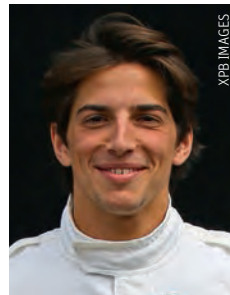

ROBERTO MERHI

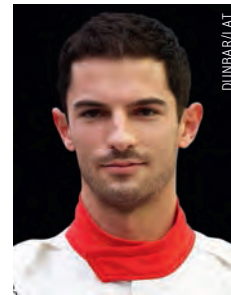

ALEXANDER ROSSI

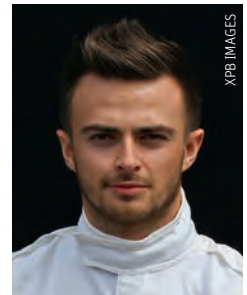

WILL STEVENS

Championship position



Driver	Starts	Best finish	Best grid	Fastest laps	Points
Roberto Merhi	13	12th	14th	0	0
Alexander Rossi	5	12th	16th	0	0
Will Stevens	17	13th	13th	0	0



Merhi tries his best with uncompetitive Marussia at Silverstone

FERRARI/LAT

Race by race car pace

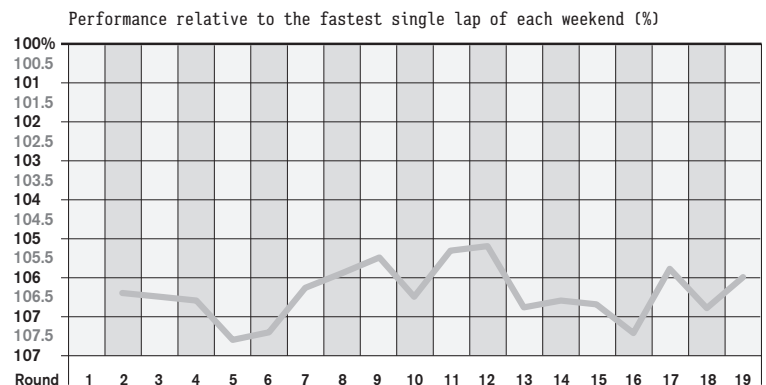



Stocking fillers!



With Christmas just around the corner, treat your car to the ultimate present! Keep re-builds and your fuel system happy this winter by filling your car's stocking with motorsport products from Anglo American Oil Company Ltd.



Sunoco Optima storage fuel is an unleaded fuel blended from highly-refined hydrocarbon blendstocks. As Optima does not contain ethanol or MTBE, and is free of oxygen, it has excellent storage characteristics, making it ideal for storing vehicles and petrol powered-equipment, especially those requiring an exceptionally stable unleaded fuel. It is specially formulated to be easy on gaskets, o rings and other fuel system components, and remains storage stable for up to 5 years.



Driven BR mineral break-in oil is a unique petroleum oil that provides optimum levels of Zinc and Phosphorus for flat tappet and aggressive valve trains and an additive package that promotes ring seal. It provides the maximum protection available for cams and lifters during initial break-in, and does not require additional ZDDP additives.

Recommended by multiple cam manufacturers, this is ideal for full power pulls on the dyno or for a night of racing. Available in SAE 10W-30, 10W-40 and 15W-50.



Driven Assembly Grease is a unique extreme pressure lube that dissolves completely in oil without clogging passageways or plugging filters. It is proven to cling to and protect surfaces during initial start-up, Driven Engine Assembly Grease delivers protection you can count on. Apply to cams and lifters for break-in protection, or use on distributor gears, rocker shafts, rocker tips, pushrod tips, wrist pins and valve guides.

Distributor of:



RACE FUELS

BORN FROM JOE GIBBS RACING

DRIVEN
DRIVEN TO WIN RACING OIL™



Anglo American Oil Company

+44 (0)1929 551557 info@aaoil.co.uk www.aaoil.co.uk

At home on road and off.

Model based design, system integration and prototype development
at the forefront of hybrid and electric powertrain concepts.



 rational
motion



ALWAYS A STEP AHEAD. From lightweight, high performance motorsport to daily use, cost-efficient and norm compliant on and off road applications - mastering the unique demands of electric and hybrid traction concepts for highly diverse scenarios is what we call daily business.

“That’s What Champions Do”

The Official Review of the 2015 FIA Formula One World Championship™

Order the superb Formula 1® Review on Blu-ray or DVD now

BLU-RAY:

Five hours 7mins - Order Now **£16.99** (SRP £24.99)

DVD:

Four hours 43mins - Order Now **£14.99** (SRP £19.99)

NTSC* DVD:

Four hours 43mins - Order Now **£14.99** (SRP £19.99)

POST FREE to UK, Eire, Germany, *N.America

DVD expected Monday 21st December.

Blu-ray due for delivery late December.

visit: **DukeVideo.com/F1-2015**

Many more Formula 1® Reviews available online at **DukeVideo.com**



© 2015 Formula One World Championship Limited. All rights reserved.
The F1 FORMULA 1 logo, F1 logo, F1 FIA FORMULA 1 WORLD CHAMPIONSHIP logo, FORMULA 1, FORMULA ONE, F1, FIA FORMULA ONE WORLD CHAMPIONSHIP, GRAND PRIX and related marks are trade marks of Formula One Licensing BV, a Formula One group company.
Licensed by Formula One World Championship Limited. All rights reserved.



DUKEVIDEO.COM - YOUR FIRST CHOICE FOR MOTORSPORT HOME ENTERTAINMENT ON THE WEB
NEW TITLES IN STOCK AND COMING SOON - 100s MORE TO CHOSE FROM ONLINE



World Rally Championship 2015
OUT NOW 2 DVD £16.99

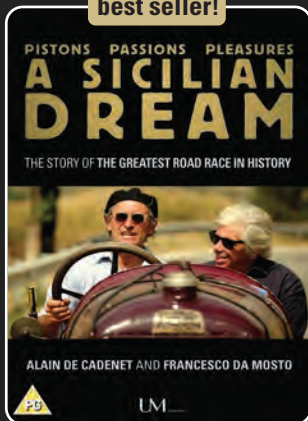

A Sicilian Dream **OUT NOW**
DVD and Blu-ray £16.99 - £19.99

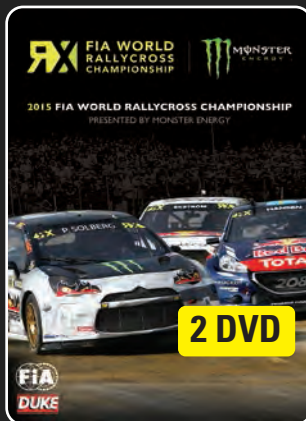

World Rallycross 2015
COMING SOON
2-DVD £16.99 Due Dec 21st

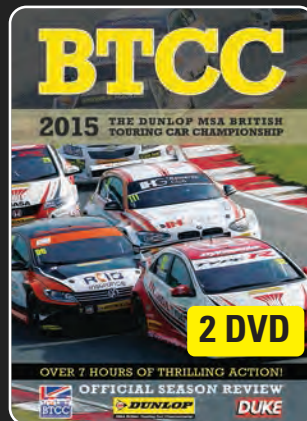

BTCC 2015 **OUT NOW**
2 DVD £16.99

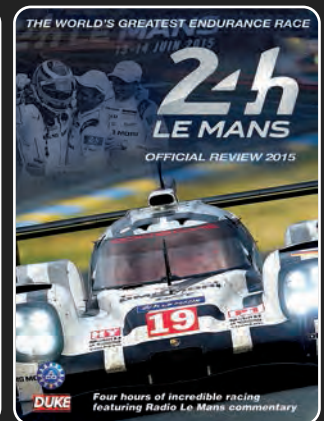

Le Mans 2015 **OUT NOW**
DVD and Blu-ray £16.99 - £19.99

Order before 21st December for UK delivery before Christmas
FREE POST ON ALL DVDS, BLU-RAYS AND CDS



visit: **DukeVideo.com**
call: **01624 640 000**

World Rally Championship 2000-09
COMING SOON
10 DVD
27+ Hours!
introductory offer £69.99





Political review

The growing power of Ferrari and Mercedes has driven new alliances to form as the sport's stakeholders eye a post-Ecclestone era

By Dieter Rencken, Special Contributor

[@RacingLines](#)

THE SEEDS FOR FORMULA 1'S 2015 SEASON WERE sown a good two months before 2014 gave way to the new year, when Fiat CEO Sergio Marchionne replaced long-time Ferrari president Luca di Montezemolo with his good self as part of an overall management restructure.

It was at this point that, for Ferrari, F1 mutated from a marginally profitable global-marketing pedestal for the company's road cars to a full-on profit centre within Gruppo Fiat. It was also the point at which Marchionne started playing an active role in F1 by attending Strategy Group and F1 Commission meetings – convened by the Italo-Canadian's former subordinate, Jean Todt.

Observers maintain Marchionne lost no time in making his former superiority over the bafflingly laissez-faire Todt clear. In addition, they claim, he flaunted his status as the sole holder of a regulatory veto (which he triggered within a year) more often than all his predecessors combined. The effects of this power historically vested in Ferrari – but previously seldom used – will roll into next year and extend through to 2020, when the current veto expires.

The crux of that matter lays in Marchionne's determination to milk Ferrari for the good of the Gruppo by spinning the company off from Fiat and listing Ferrari on New York's stock exchange. The successful IPO occurred in late October and directly and indirectly fed \$4 billion into the Fiat-Chrysler Alliance.

With that in mind, is it any wonder that every move made against Ferrari's political power and commercial dominance of F1 is met

with stony resistance? Never was this clearer than when Todt attempted to introduce cost caps on engines and operations, and Ferrari vetoed every such move.

Where Todt announced his intention to reduce the price for two-car annual supplies to around €12 million (£8m), Ferrari simply vetoed the plan, then mobilised its troops among sponsors and circuit promoters to vote against the alternate engine Todt wanted to introduce from 2018 onwards as a foil for the cost of the current hybrids.

True, the parties eventually struck a compromise: a Powertrain Working Group was formed with the specific mandate to reduce prices, increase supplies to other teams where possible, and increase noise. But cynics recall the results >>

“F1 has mutated from a marketing pedestal to a profit centre”

Fiat CEO Sergio Marchionne wields great power



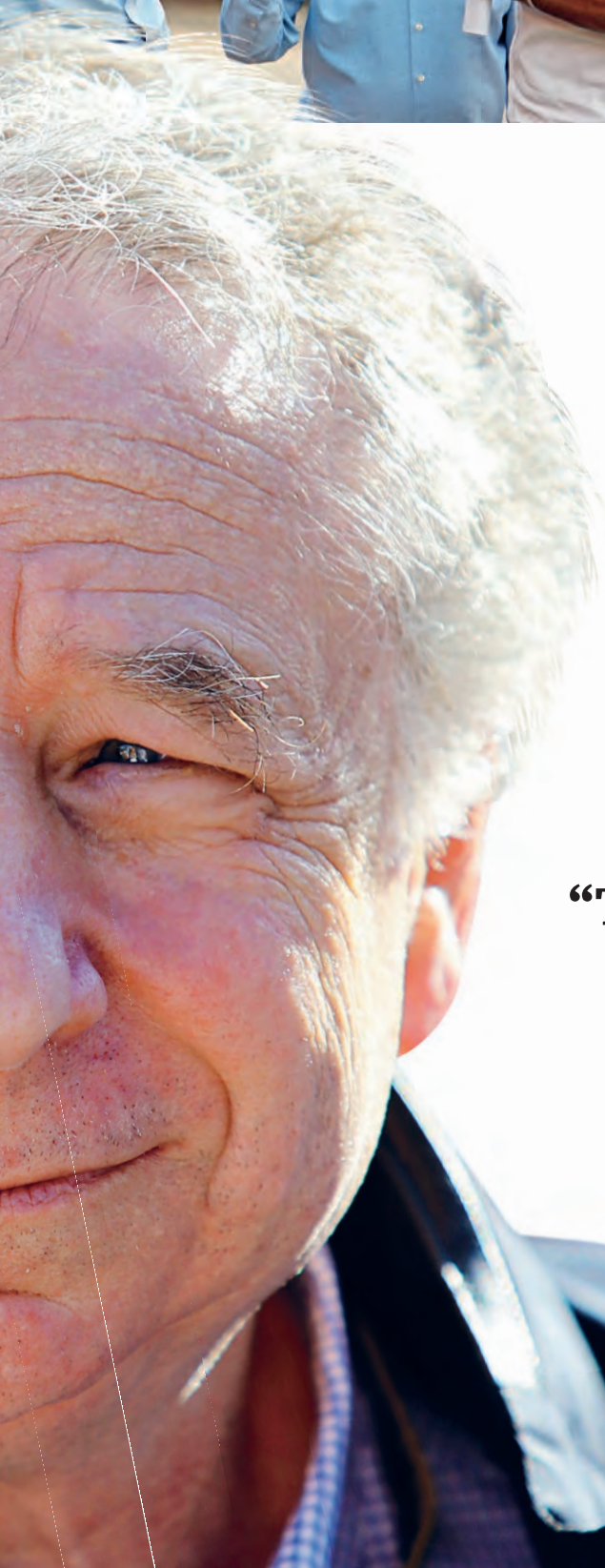

“The Mercedes-Ferrari axis forced Todt and Ecclestone together”

FIA president Todt has aligned with FOM

of the similarly constituted Overtaking Working Group, which delivered uglier cars and not much more overtaking.

Whatever, engine politics became the defining issue of 2015. But here Ferrari worked hand in glove with Mercedes. Seldom, if ever before, has there been so much public accord and agreement between two major competitors; so much so, in fact, that Mercedes motorsport director Toto Wolff regularly refers to Ferrari as “our frenemy” while smilingly embracing Maurizio Arrivabene, his Italian opposite number. In virtually every Friday FIA press conference there was total agreement between them on otherwise contentious points.

Take the latest political storm as an example. The Mercedes-Ferrari axis forced Todt and Formula One Management CEO Bernie Ecclestone into an uncomfortable double act, both championing the budget engine proposal.

Mercedes also played a leading – albeit far from primary – role in the ongoing Red Bull/Renault farrago. Having spoken of a deal to supply engines, Mercedes decided against it when pen hovered above paper. The full ins and outs remain known only to the players directly involved, but paddock chatter has it that Mercedes non-executive chair Niki Lauda agreed the deal, whereafter Wolff torpedoed it.

This caused fallout on two fronts: first, a rift is believed to have developed between the two Mercedes executives; second,

Red Bull Racing, together with sister squad Toro Rosso, was left engineless, having served notice on Renault after a winless season in which the partnership broke down irretrievably in a storm of mutual recriminations.

Red Bull’s management had been less than complimentary about the engine partner with which it won its last of four straight titles just two years ago. Yet when it became apparent that no engines would be making the 50-odd-mile journey from Mercedes’ Brixworth facility to Red Bull Towers, they rushed to reopen diplomatic channels once again, having already found doors closed at Ferrari and Honda.

That was not the only saga Renault found itself embroiled in: earlier in the year, as it became clear developments had not yielded much more power or reliability, and Red Bull’s criticism became increasingly trenchant, the

French company suggested that a return to full team ownership could cure its ills.

Four teams were candidates, including Lotus, which Renault



had sold to Genii Capital in 2010 for knockdown money in the wake of the Singapore Grand Prix crash controversy.

Beleaguered Lotus initially claimed ignorance of any such intentions until July, when a string of pending creditor actions became public knowledge. Then, suddenly, Renault was hailed as a potential saviour, and the motor company even issued a letter of intent to stave off urgent actions, which postponed by 10 weeks Lotus's date in the High Court to face Her Majesty's Revenue & Customs over unpaid PAYE contributions.

In the interim, the chances of any deal reaching completion wavered from 'full-on' to 'totally off' almost on a weekly basis, and the increasingly cash-strapped Lotus suffered embarrassments such as being locked out of hospitality units until circuit bills were paid. Its freight was variously delivered at the last minute, giving the crew on the ground additional challenges in getting ready for on-track action.

That a business turning over billions in any currency is unable to ensure the survival of one its longest-standing operations (Lotus joined F1 in 1981 as Toleman) absolutely beggars belief. The situation is as much a reflection on the team management's ability to bring in additional funds via sponsorship as it is of venture fund CVC Capital Partners, which controls the sport's commercial rights and relentlessly squeezes every penny.

This delay does not reflect well on Renault either, and is understood to be rooted in demands put to FOM – majority controlled by CVC – for the financial benefits that flow from the team's status as a double championship winner in 2005-06. These have been (re)negotiated from pillar to post and back since July, and the matter has been complicated further by the official European Commission complaint filed by two teams.

Sauber and Force India – who consider themselves disadvantaged through their omission from the Strategy Group, and the sport's opaque revenue structures – have sought outside help in resolving their claims. The figures are large: Ferrari earns double the share of Williams, despite the Italian squad ending behind the British team in the 2014 classification.

There has been no news at the time of writing whether the action has legs, nor any prognosis of outcome should it even go the distance, but the move has certainly caused prospective buyers of the sport, the number of which seemingly grows with each passing month, to place such plans on hold.

Unlike last year no teams went under – indeed, nascent Haas, by all reports, made excellent progress – and no outright war erupted, yet the uneasy feeling lingers that full or partial meltdown is on the horizon, and that the major players are biding their time for a power grab. After all, Ecclestone celebrated his 85th birthday in October, yet still no clear succession plan has been instituted by CVC... ❄

Lotus: the art of brinkmanship

Renault's acquisition of Lotus is arguably the longest on-off saga in F1 history, having first surfaced during the Australian Grand Prix. Negotiations between the parties stretched across the full season.

Four factors complicated matters: Lotus's precarious financial situation; hard-nosed Renault CEO Carlos Ghosn's reluctance to go back into F1 as a constructor; the fact that failure to do a deal could result in the exit of three teams, namely Lotus and the two Red Bull squads; and Ghosn's love of a hard bargain. His push for equal status with other double champions stretched F1's commercial and governance structures to the max.

In Singapore, an insider suggested the deal's chances were less than fifty-fifty, and as late as Abu Dhabi Saturday he put the odds at no better. So it came down to a Sunday meeting between Renault



Ecclestone faced loss of three teams

marketing/motorsport boss Jerome Stoll and Bernie Ecclestone, whose CVC Capital Partners boss Donald Mackenzie, also present, holds the final say. A compromise was agreed as the cars lined up on the grid.

All that remained was for Stoll to persuade Ghosn no better deal could be cut, and for Ghosn to give the nod to completion.



Jolyon Palmer will drive for Renault next year

ALL PICS: XPB IMAGES

The best and worst

Whenever an F1 car raced this year, *Autosport* was there in numbers.

Lawrence Barretto ranks the 19 races

Season ratings

The rankings show how the races fared in order of entertainment, and how they compared to 2014:

- █ 2015 RATING UP
- █ NO CHANGE
- █ 2015 RATING DOWN
- █ NEW ENTRY

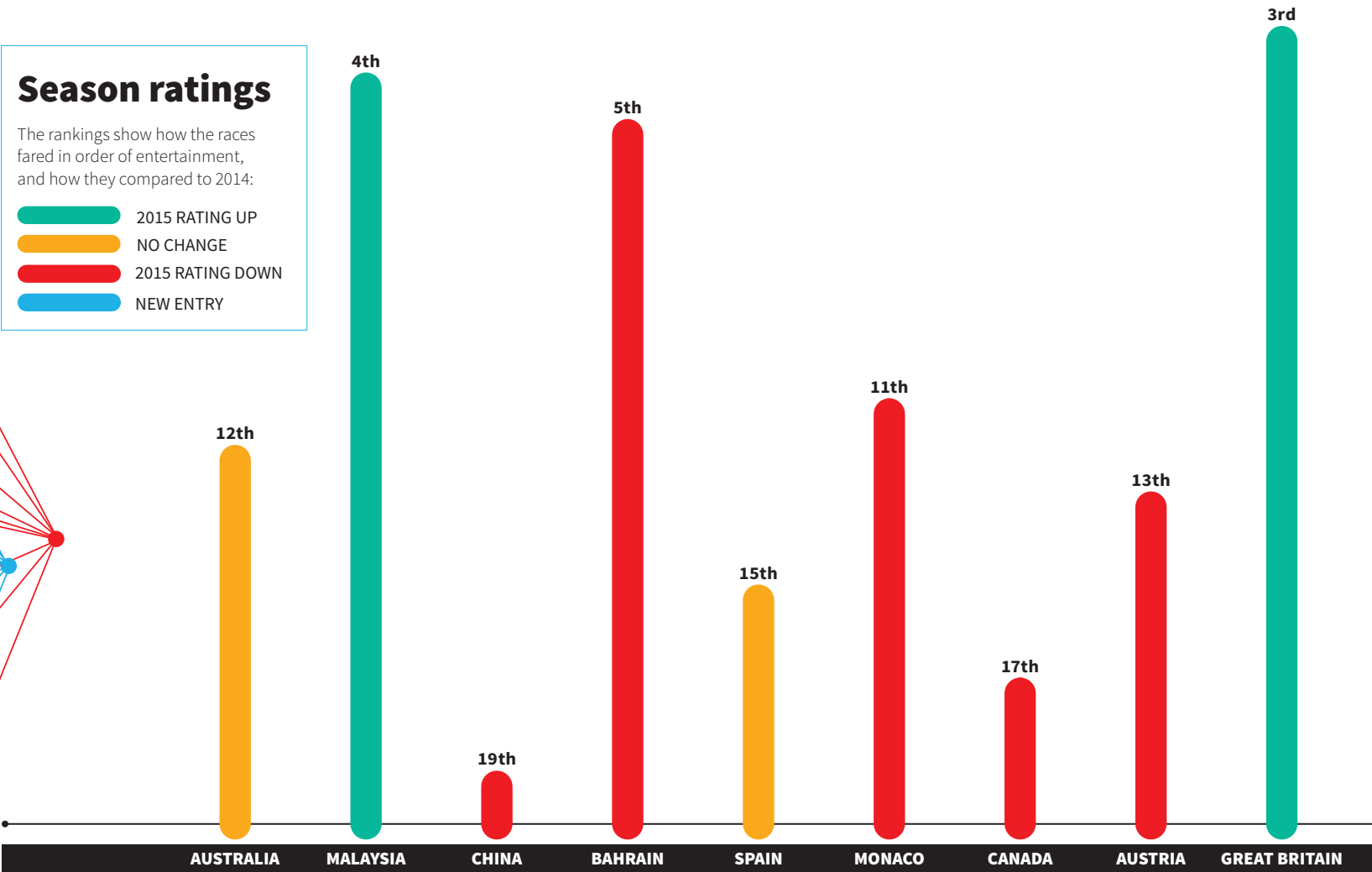

1 UNITED STATES ▲ UP 6
When bad weather prevents teams from painstakingly eliminating variables, it usually delivers a cracking grand prix. Take this year's race at Austin. Faced with having to run qualifying and the race on the same day, having completed limited running in practice, talent and instinct shone through. Drivers who could read the changing conditions excelled, while those who struggled to do so, well... struggled. The race had everything from lead changes – even a Red Bull found itself at the front – to wheel-to-wheel battles and the emergence of a star in Max Verstappen who finished a brilliant fourth. That it was a 'gust of wind' that blew Rosberg off track and gifted Hamilton the title was disappointing. But it was fitting he won it in one of the most thrilling races in living memory.

2 HUNGARY ▼ DOWN 1
Just edged out by the USA this year, the Hungarian Grand Prix delivered a second successive thriller. The form book was ripped up as Mercedes had a shocker, Vettel nailed it, and even McLaren had reason to be celebrate as Alonso scored a rare points finish with fifth. The Hungaroring did good.

3 GREAT BRITAIN ▲ UP 8
Silverstone delivered a race that rewarded a full house. An electric start from Williams lit up the grand prix as Massa and Bottas ran one-two. The weather then intervened, with rain coming to Mercedes' rescue. That prompted battles throughout the field and some standout performances from the youngsters.

4 MALAYSIA ▲ UP 13
After Mercedes dominated Australia, Vettel provided just the tonic. The sweaty conditions suited Ferrari and, together with smart tactics and impressive pace from Vettel, the Scuderia took victory. Raikkonen's fightback through the field was a nice sideshow, while Bottas and Verstappen nailed brilliant passes on team-mates.

5 SAUDI ARABIA ▼ DOWN 2
This race was not quite the thriller of 2014, as Hamilton took an easy win. But the vigorous battle for the trio of places behind him ensured that there was race-long entertainment under the lights. The desert race at Sakhir, which made its debut in 2004, is starting to earn its place on the calendar.

6 RUSSIA ▲ UP 12
Russia redeemed itself after last year's snoozefest with an action-packed race, aided in part by the slippery surface of the Sochi circuit. Hamilton cruised at the front, but Raikkonen v Bottas Part I spiced up the finale, allowing Perez to snatch a shock podium in the Force India after a super-long stint on the softs.

7 SINGAPORE ▲ UP 6
This one will be remembered as the race where that bloke took a stroll on the track before thinking better of it. Vettel was mighty under the lights, taking his 42nd victory, with Ricciardo claiming second ahead of Raikkonen as Mercedes struggled. Two safety cars ensured it remained nip and tuck.

races of 2015

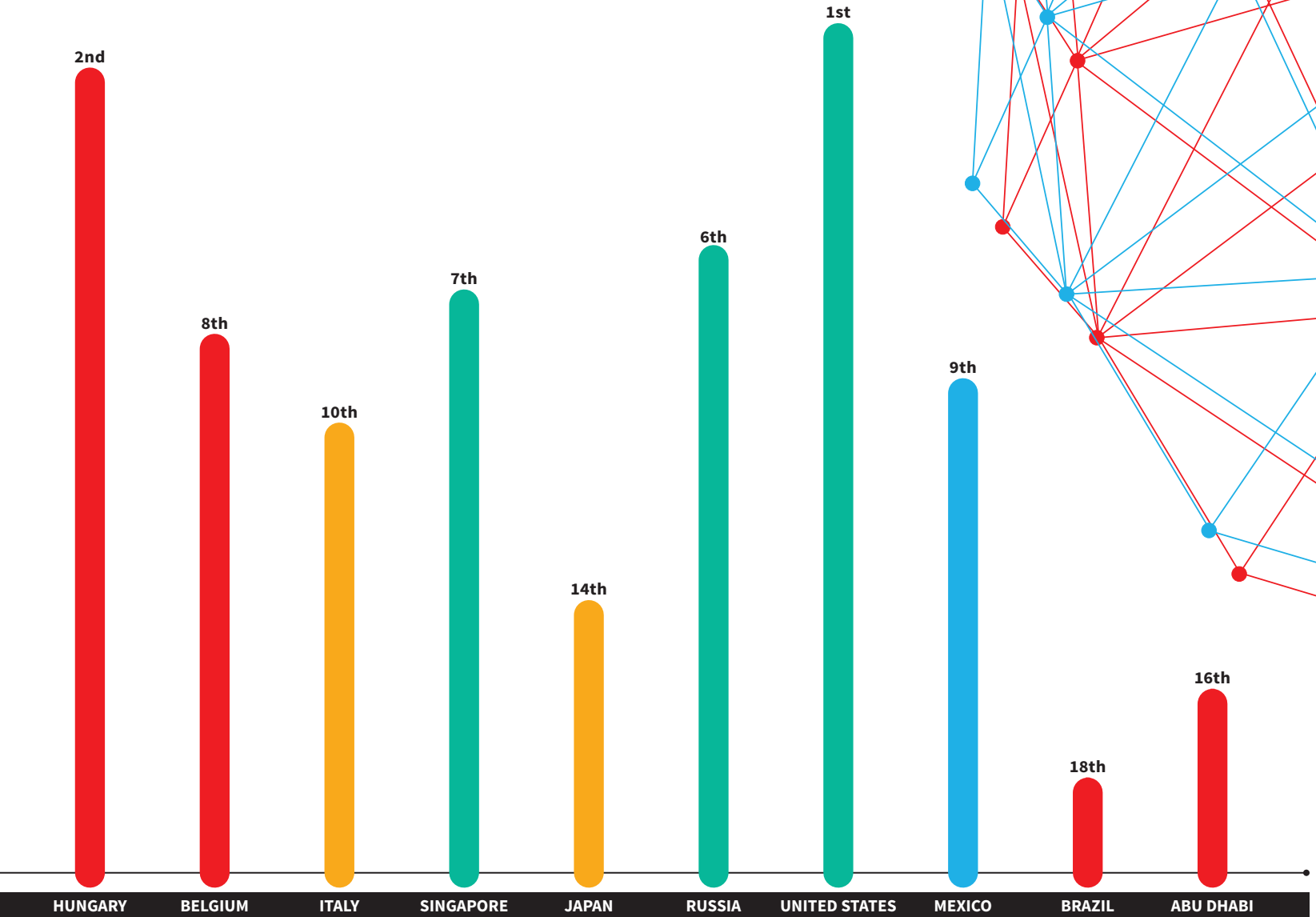

8 BELGIUM
▼ DOWN 4
There was an exploding tyre, a Lotus podium and an aborted start in the first race since new clutch rules. And Hamilton won again.

9 MEXICO
▶ NEW ENTRY
Raikkonen and Bottas were at it again, this time the former coming off worse. It was no thriller but the packed house still cheered the show from lights to flag.

10 ITALY
▶ NO CHANGE
Monza failed to conjure up a storming race, with only a smidgen of drama when Rosberg's engine expired. But the track remains an incredible venue and the Tifosi again delivered a fantastic atmosphere.

11 MONACO
▼ DOWN 5
A Mercedes strategic blunder, caused by calling in leader Lewis Hamilton under the safety car and handing victory to team-mate Nico Rosberg, ensured a controversial end to what was an otherwise processional race. Oh, and Monaco remains a great place to host an F1 race.

12 AUSTRALIA
▶ NO CHANGE
It says something when the most interesting thing that happened on a race weekend took place off it with Giedo van der Garde taking Sauber to court. There were, however, notable debuts from Felipe Nasr and Max Verstappen, both scoring points behind a Mercedes cruise in the park.

13 AUSTRIA
▼ DOWN 8
Rosberg beat Hamilton in a largely unexciting race. The festival atmosphere of 2014 was toned down, but the thumping electro-music wake-up call remained.

14 JAPAN
▼ DOWN 5
The Japanese fans in their home-made F1 hats turned out in force and once more made this event, as Hamilton and Rosberg gave Mercedes kittens running each other close at the start.

15 SPAIN
▶ NO CHANGE
As has become the case in recent years, the Barcelona race did not serve up a classic – there was very little drama.

16 ABU DHABI
▼ DOWN 7
Similar to Spain, but the warmth and the spectacle made it a nice way to end the season.

17 CANADA
▼ DOWN 15
It was all too easy for Mercedes, while Vettel raced from 18th to fifth. Won't live long in the memory.

18 BRAZIL
▼ DOWN 4
Like Canada but less exciting. Hamilton snappy over strategy in a forgettable race.

19 CHINA
▼ DOWN 3
Merc cakewalk and nearly empty grandstands.

2015 STATISTICS

Average car performance

Based on an average of each car's fastest single lap of each race weekend, converted into a percentage and calculated as an average

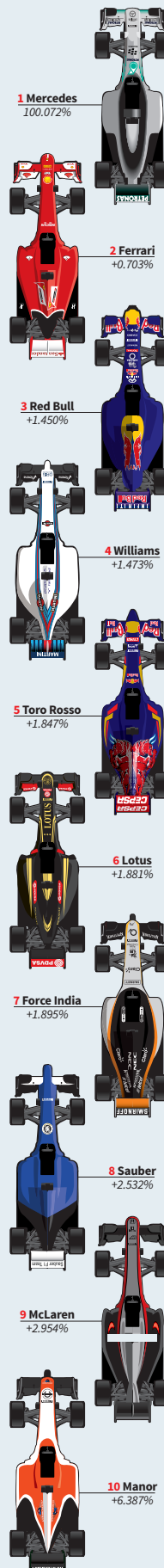

Drivers' standings

POS	DRIVER	AUS	MAL	PRC	BRN	E	MC	CDN	A	GB	H	B	I	SGP	J	RUS	USA	MEX	BR	UAE	PTS
1	Hamilton	1st	2nd	1st	1st	2nd	3rd	1st	2nd	1st	6th	1st	1st	ret	1st	1st	1st	2nd	2nd	2nd	381
2	Rosberg	2nd	3rd	2nd	3rd	1st	1st	2nd	1st	2nd	8th	2nd	17th	4th	2nd	ret	2nd	1st	1st	1st	322
3	Vettel	3rd	1st	3rd	5th	3rd	2nd	5th	4th	3rd	1st	12th	2nd	1st	3rd	2nd	3rd	ret	3rd	4th	278
4	Raikkonen	ret	4th	4th	2nd	5th	6th	4th	ret	8th	ret	7th	5th	3rd	4th	8th	ret	ret	4th	3rd	150
5	Bottas	DNS	5th	6th	4th	4th	14th	3rd	5th	5th	13th	9th	4th	5th	5th	12th	ret	3rd	5th	13th	136
6	Massa	4th	6th	5th	10th	6th	15th	6th	3rd	4th	12th	6th	3rd	ret	17th	4th	ret	6th	ex	8th	121
7	Kvyat	DNS	9th	ret	9th	10th	4th	9th	12th	6th	2nd	4th	10th	6th	13th	5th	ret	4th	7th	10th	95
8	Ricciardo	6th	10th	9th	6th	7th	5th	13th	10th	ret	3rd	ret	8th	2nd	15th	15th	10th	5th	11th	6th	92
9	Perez	10th	13th	11th	8th	13th	7th	11th	9th	9th	ret	5th	6th	7th	12th	3rd	5th	8th	12th	5th	78
10	Hulkenberg	7th	14th	ret	13th	15th	11th	8th	6th	7th	ret	DNS	7th	ret	6th	ret	ret	7th	6th	7th	58
11	Grosjean	ret	11th	7th	7th	8th	12th	10th	ret	ret	7th	3rd	ret	13th	7th	ret	ret	10th	8th	9th	51
12	Verstappen	ret	7th	17th	ret	11th	ret	15th	8th	ret	4th	8th	12th	8th	9th	10th	4th	9th	9th	16th	49
13	Nasr	5th	12th	8th	12th	12th	9th	16th	11th	DNS	11th	11th	13th	10th	20th	6th	9th	ret	13th	15th	27
14	Maldonado	ret	ret	ret	15th	ret	ret	7th	7th	ret	14th	ret	ret	12th	8th	7th	8th	11th	10th	ret	27
15	Sainz	9th	8th	13th	ret	9th	10th	12th	ret	ret	ret	ret	11th	9th	10th	ret	7th	13th	ret	11th	18
16	Button	11th	ret	14th	DNS	16th	8th	ret	ret	ret	9th	14th	14th	ret	16th	9th	6th	14th	14th	12th	16
17	Alonso	-	ret	12th	11th	ret	ret	ret	ret	10th	5th	13th	18th	ret	11th	11th	11th	ret	15th	17th	11
18	Ericsson	8th	ret	10th	14th	14th	13th	14th	13th	11th	10th	10th	9th	11th	14th	ret	ret	12th	16th	14th	9
19	Merhi	DNQ	15th	16th	17th	18th	16th	ret	14th	12th	15th	15th	16th	-	-	13th	-	-	-	19th	0
20	Rossi	-	-	-	-	-	-	-	-	-	-	-	-	14th	18th	-	12th	15th	18th	-	0
21	Stevens	DNQ	DNS	15th	16th	17th	17th	17th	ret	13th	16th	16th	15th	15th	19th	14th	ret	16th	17th	18th	0
22	Magnussen	DNS	-	-	-	-	-	-	-	-	-	-	-	-	-	-	-	-	-	-	0

12

Number of one-tuos taken by Mercedes – a new record for a single grand prix season

5th

Position Sauber driver Felipe Nasr finished on his F1 debut in the Australian GP

43

Lewis Hamilton's victory at Austin was his 43rd, putting him third in the all-time list

387

Number of laps spent by Sebastian Vettel in third place during the 19 races of 2015

252

Fernando Alonso notched up his 250th GP start during the season

80

Kimi Raikkonen claimed his 80th F1 podium finish in Abu Dhabi – the first was in 2003

Constructors' standings

POS	DRIVER	AUS	MAL	PRC	BRN	E	MC	CDN	A	GB	H	B	I	SGP	J	RUS	USA	MEX	BR	UAE	PTS
1	Mercedes	43	33	43	40	43	40	43	43	43	12	43	25	12	43	25	43	43	43	43	703
2	Ferrari	15	37	27	28	25	26	22	12	19	25	6	28	40	27	22	15	0	27	27	428
3	Williams	12	18	18	13	20	0	23	25	22	0	10	27	10	10	12	0	23	10	4	257
4	Red Bull	8	3	2	10	7	22	2	1	8	33	12	5	26	0	10	1	22	6	9	187
5	Force India	7	0	0	4	0	6	4	10	8	0	10	14	6	8	15	10	10	8	16	136
6	Lotus	0	0	6	6	4	0	7	6	0	6	15	0	0	10	6	4	1	5	2	78
7	Toro Rosso	2	10	0	0	2	1	0	4	0	12	4	0	6	3	1	18	2	2	0	67
8	Sauber	14	0	5	0	0	2	0	0	0	1	1	2	1	0	8	2	0	0	0	36
9	McLaren	0	0	0	0	0	4	0	0	1	12	0	0	0	0	2	8	0	0	0	27
10	Marussia	0	0	0	0	0	0	0	0	0	0	0	0	0	0	0	0	0	0	0	0

221.9 mph

Highest speed of 2015, achieved by Williams driver Felipe Massa at Mexico City

5th

Force India's fifth place in the championship was its best finish since 2001 (as Jordan)

57

Number of days of on-track action during race weekends, with three days at each race

1127

The most laps completed by any driver in races during 2015 – by Sebastian Vettel

16

The Mercedes team matched its 2014 record for total wins in a grand prix season

23

Mercedes fell one short of matching the Williams record for consecutive poles

Wins

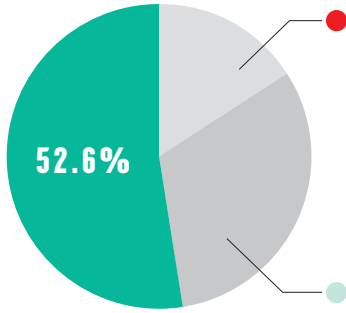

● Hamilton 10 ● Rosberg 6 ● Vettel 3

Poles

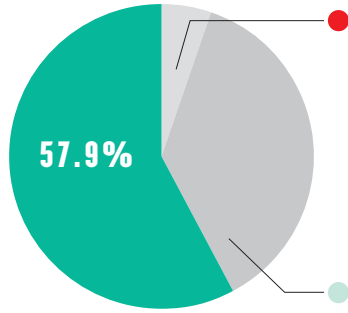

● Hamilton 11 ● Rosberg 7 ● Vettel 1

Fastest laps

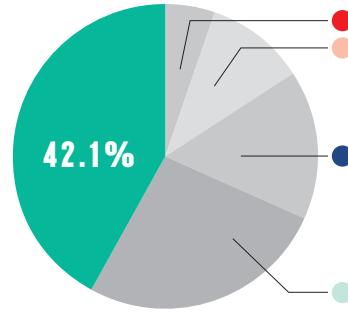

● Hamilton 8 ● Rosberg 5 ● Ricciardo 3 ● Raikkonen 2 ● Vettel 1

First-lap heroes and villains

Which drivers gained or lost the most positions over the season from starting position to the end of the first lap

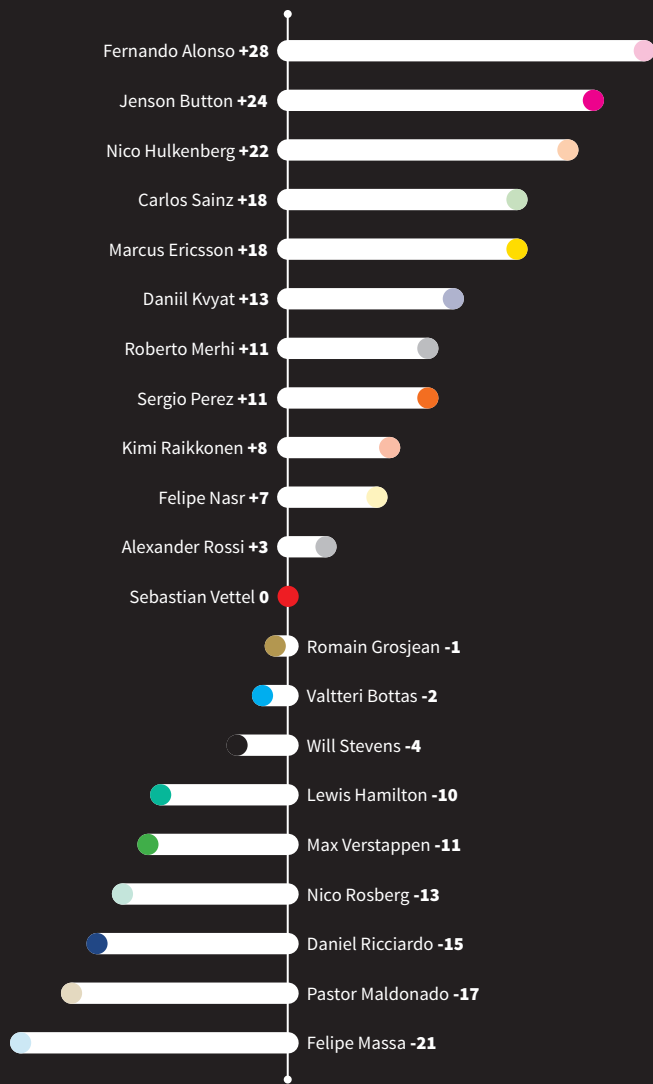

Percentage of season's points scored

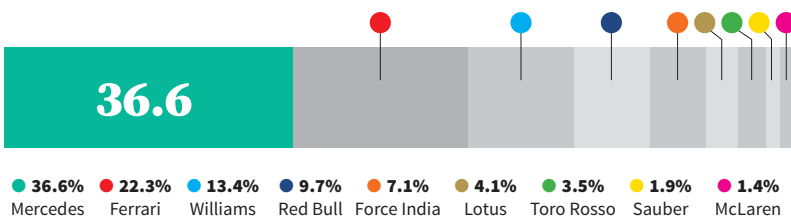

Total number of points on offer in 2015 season 1919

Laps led

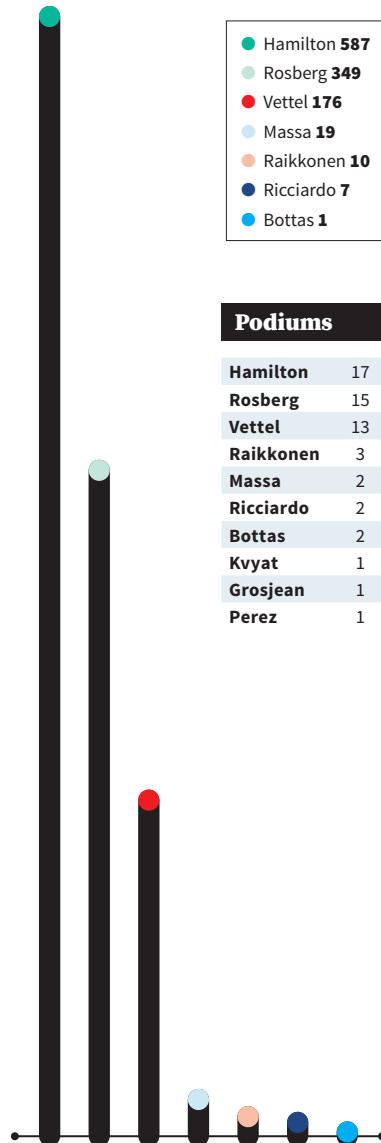

Podiums

Hamilton	17
Rosberg	15
Vettel	13
Raikkonen	3
Massa	2
Ricciardo	2
Bottas	2
Kvyat	1
Grosjean	1
Perez	1

Super-race

This is generated by taking the average race position, based not just on finishing position but on the place held on each lap



Qualifying head to head

Rosberg	7	12	Hamilton
Ricciardo	12	7	Kvyat
Massa	8	11	Bottas
Alonso/Magnussen	9	9	Button
Perez	8	10	Hulkenberg
Sainz	10	9	Verstappen
Grosjean	17	2	Maldonado
Ericsson	10	9	Nasr
Stevens	11	6	Merhi/Rossi

Excludes sessions when one driver couldn't run



FORMULA 1

McLaren MP4-X concept

McLAREN HAS RELEASED ITS VISION OF what the future of Formula 1 could be with its MP4-X concept car.

The resulting vehicle is a mix of the plausible and several far wackier ideas. This goes to show the MP4-X is not just a styling or PR exercise, but a serious stab at creating a new concept.

Incorporating ideas from its technological arm McLaren Applied Technologies and its race team, McLaren has “combined a number of F1’s key ingredients – speed, excitement and performance – with the sport’s emerging narratives, such as enclosed cockpits to enhance driver safety, and hybrid power technologies”.

The result is a car that is clearly F1-related, with a long, slim chassis, wings and wide-spaced wheels. It’s clear McLaren is challenging the preconceptions of what many think make up an F1 car, so the MP4-X concept has an enclosed cockpit, closed wheels and an increased amount of electrical drive.

For many followers of F1, discarding open cockpits and open wheels seems sacrilegious, but there are good reasons for doing so.

As F1 strives to be a relevant and sustainable

sport in a changing world, burning fossil fuels to gain performance isn’t going to be tolerated.

Already F1 is ERS-focused, but the new concept uses even more energy recovery to power an electric drive, adopting ideas such as batteries integrated into the structures and solar panels. These are then mated to a super-efficient downsized internal-combustion engine.

A boost in electrical energy could be provided by a ‘charging lane’ in the track, transferring energy to the batteries via induction as the driver passes over it.

Much of an F1 car’s drag comes from its open wheels – along the straights, a large proportion of its power is used to fight air resistance. So enclosed wheels make a lot of sense, with wheel fairings, last seen in F1 in 2009, reducing drag.

“It suggests materials that regain shape after damage”

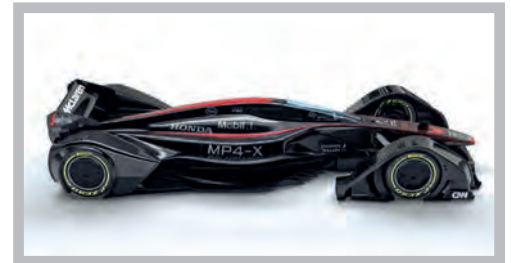
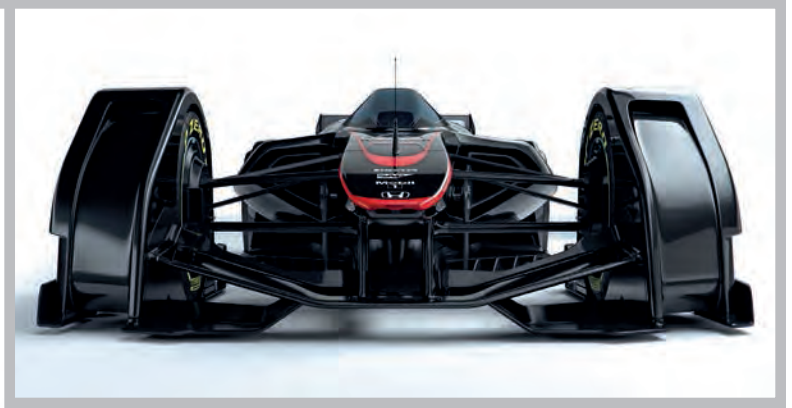

McLaren's F1 concept car is more than just a pipedream, as Craig Scarborough explains

offers glimpse of Formula 1 future

Downforce would be created largely by ground effect, with the car featuring large underbody tunnels, using space freed up by the reconfigured drivetrain. The external wings, which appear to be made into smaller, simpler conceptualised shapes, will feature moveable technology – from physical movement to morphing panels and the use of electrical plasma – to turn the air.

With such a plethora of aero aids, the car would be weighted with downforce, making it fast around turns. The closed design and adaptive aero would make it equally potent on straights.

A closed cockpit has aero advantages, but most importantly the safety benefits are obvious, and McLaren has given thought to the driver exiting the cockpit in its design.

The cockpit itself features some far-fetched ideas, with no manual controls, but neural links to the driver's brain to control the car, intelligent race suits, holographic dash displays and driver telemetry. But equally, the closed cockpit allows some clever in-car cameras to provide a driver's point of view on TV, which would enhance the experience for those tuning in to the race by putting them at the heart of the action.

With a very different design outlook, the actual make-up of the materials could be equally advanced. McLaren suggests materials that have the ability to regain their shape after accident damage, as well as the aforementioned batteries being incorporated into the car's structure.

What may seem far-fetched is the suggestion that the chassis could have self-diagnosing damage systems, but this is already adopted in aircraft airframes with acoustic detection.

Enclosing the chassis, the bodywork would not have sponsor stickers attached, but digital panels enabling the sponsor logos to change while the car is in motion. The pods enclosing the wheels allow for better placement of tyre sensors, perhaps not only reading temperatures but also wear and tyre integrity, to help predict ideal pitstop points and warn of imminent tyre failure.

This is the third futuristic F1 concept to come via a team, since Red Bull and Ferrari have released ideas taking similar visual approaches. But it could be argued that McLaren's is the most thoroughly conceptualised idea and, in some areas, the most plausible.

Certainly the base aero, drivetrain and structure concepts are realistic approaches, albeit with major changes required in the rules and preconceptions of what an F1 car should be. And some of the advanced technologies – which seem science-fiction at first – are realistic and could be incorporated as the technology matures.

Beyond those ideas, the wilder technologies aren't likely to be in any sort of F1 roadmap in the near future, so perhaps the purpose of including those is solely to provoke some deeper thought and grab some attention.

But the MP4-X shows how far road and racecar technology will go in the coming decades. Even the basic paradigm of how a car is driven, if driven manually at all, could be challenged with the advanced rate of technological development.

Currently, F1 doesn't have this sort of medium or long-term technological roadmap, and even the rules being planned for the short term are simple iterations of the current regulations.

Perhaps Formula 1 needs this sort of thinking to set itself in a direction that would keep pace with a rapidly changing world.

CRAIG SCARBOROUGH

HOW AERO LIMITS SHOULD FORCE LMP1 COSTS DOWN

LMP1 MANUFACTURERS will be allowed to race only three distinct aerodynamic configurations in next year's World Endurance Championship as part of a wide-ranging cost-cutting drive.

The introduction of the limit, which will then be reduced to two for the 2017 season, follows the escalation of aero development by Porsche and Audi through 2015. They each raced at least three different bodywork specifications over the course of the season.

The new rule came out of the budget-reduction working group on which the P1 manufacturers sit and was agreed at last week's FIA World Motor Sport Council. The final wording of the regulation is due to be worked out shortly.

Toyota Motorsport technical director Pascal Vasselon said: "In 2014, Audi and us were using two packages, but this year Porsche maybe even had four. The idea is to cut back to return to the situation we were in before progressively."

The rule will cover major body items, such as wheelarches and engine covers, but there will be freedom in terms of what Vasselon called "cheaper items" such as vanes and diveplanes.

Porsche LMP1 technical boss Alex Hitzinger said that it was

also important to "allow freedoms in order to balance the cars for different tracks".

Hitzinger added the rule would not result in significant savings next year, but would when the lower limit comes into force in 2017.

"The rule has really been devised to avoid real excesses in terms of aero development," he explained.

The new rule will go hand in hand with restrictions on the hours each manufacturer can spend in the windtunnel over the course of a year. This will be set at 1200 hours next year and then reduced to 800 hours for 2017.

The WEC rulemakers and the manufacturers have opted against limitations on the use of computational fluid dynamics (CFD).

"It is not really possible to police and it is less relevant to cost reduction," said Vasselon.

Hitzinger said Porsche was happy to accept the limitations: "All we want is a level playing field. Then it's up to us to do a better job."

Audi is known to have opposed limits on windtunnel time for 2015 and is understood to have maintained the same position.

The limit of 50 car days of testing, introduced this year, will be reduced to 43 next season, then 40 in 2017.

GARY WATKINS

Renault works team returns

The takeover of Enstone is as good as complete, but what can we expect of it in the coming years?

A

AFTER MONTHS OF NEGOTIATIONS AND deliberation, Renault CEO Carlos Ghosn finally took the decision last week that the French manufacturer would return to Formula 1 as a works team in 2016.

It is a call that has been a long time in coming, not least due to the talks that unfolded between Renault and F1 supremo Bernie Ecclestone regarding the constructors' championship bonus and historical payments.

Renault has committed itself to F1 for the next nine years, through to the end of 2024. Significantly, that's four years beyond the 2020 agreements in place between Ecclestone and the remaining teams on the grid.

It is a serious signal of intent from Renault in its bid to return to the forefront of F1 after believing itself to be unappreciated by former partner Red Bull in

powering the team to four consecutive years of success from 2010-13.

Since the introduction of the 1.6-litre V6 turbocharged hybrid power units at the start of 2014, Renault has found itself constantly slated by Red Bull triumvirate Dietrich Mateschitz, Christian Horner and Helmut Marko.

The criticism reached such a crescendo, one of Renault's options was to quit F1 altogether, and this was no empty threat. It cannot hide from the fact that its engines have been found wanting, both in terms of reliability and performance, and lagging behind Mercedes and Ferrari.

So what can we expect for 2016? In many respects, it will be a transitional year. Inroads into reliability have at least been made as the number and variety of faults have declined over time, and the team should feel far more secure about that side of things.

Red Bull's 'trial' of Renault's upgraded power unit in Brazil did not appear to yield the expected results on the performance side, with Daniel Ricciardo suggesting the manufacturer "should go back to the drawing board". Renault countered by claiming there was additional speed, and it now has a platform on which to work over the winter going into '16.

Crucially, now Renault is working primarily for itself – despite the fact that it has a renewed contract deal with Red Bull for next year that means the team will run TAG Heuer-badged engines – it has the budget for development. It is believed that Renault will be operating on a package worth around \$250 million (£165m) per annum, from a variety of different sources, including advanced payments, sponsorships and driver deals.

But while it is returning to Enstone, and knows the facilities well, do not expect it to be a force in 2016. That would be too much too soon. Instead, judge Renault on how it fares in '17, when it will have had a year to gain a foothold and had a raft of new regulations to work on.

IAN PARKES



STALEY/LAT





Meeke could remain with Citroen in 2016... but Toyota wants him

WORLD RALLY CHAMPIONSHIP

One week for Meeke

KRIS MEEKE HAS JUST OVER A WEEK to decide on his World Rally Championship career, with offers on the table from both Toyota and his current employer Citroen.

For the first time, he's in control of his own destiny, not sitting by the phone and waiting. Meeke's not saying a word – not even 'no comment' – but Citroen chief Yves Matton and Toyota boss Tommi Makinen have made their positions quite clear: they both want him to lead their team into 2017.

The question for Meeke is which road to take: with the world's biggest car maker or world rallying's most successful marque?

Citroen's C3 WRC is not far from being ready to test, whereas Makinen's Yaris WRC is still at least four months away. And then there's the chance for Meeke to keep his hand in with a limited programme in a 'private' DS 3 WRC next season.

But when a four-time world champion says: "We would be completely happy to see Kris in our team," that's hard to ignore too.

Next Friday's deadline for Monte Carlo entries will bring this speculation to an end. If Citroen wants Meeke, it'll have to be a done deal by then.

DAVID EVANS

TOP 3

Formula 1 engine badges

Red Bull's Renault engines will be badged as 'TAG Heuer' next season. Here are F1's best 'dishonest' engine identities



#1 TAG

The TAG Group badged the Porsche V6 turbo used by McLaren from late 1983 to '87. It powered the team to 25 wins and a combined total of five drivers' and constructors' titles.



#2 PETRONAS

For eight seasons from 1997 to 2004, Sauber used customer Ferrari V10s. Malaysian oil and gas giant Petronas became an 'engine maker', thanks to its sponsorship deal.



#3 MEGATRON

After BMW pulled out of F1 at the end of the 1986 season, its engines lived on as Megatrons. Run by Arrows for two more years, and Ligier in '87, it was a podium finisher in its last year.

INTERNATIONAL ROUND-UP



RED BULL SPLITS FROM INFINITI

Red Bull has confirmed it is to split from long-time F1 commercial partner Infiniti at the end of the year. The move comes in the wake of Red Bull announcing its engine-branding tie-up with new sponsor TAG Heuer. Red Bull will not promote the Renault-Nissan alliance.

TORO ROSSO FERRARI DEAL CONFIRMED

Ferrari will supply Toro Rosso with year-old customer engines next year, the team has confirmed. This follows the FIA rubberstamping the rules allowing old-specification engines to be supplied from next year after permitting Manor's Ferrari deal in 2015.

SAUBER COULD LAND HONDA ENGINES

Sauber is in the running to become the second team to be powered by Honda in Formula 1 alongside McLaren, but not until 2017 at the earliest. It is understood that any such deal would be a customer one, with the Swiss team having to pay for its engine supply.

RIVOLA TO RUN FERRARI ACADEMY

Massimo Rivola will take over the Ferrari Driver Academy as part of a restructure of the team's Formula 1 young-driver programme. He will replace Luca Baldisserrri in a move set to be confirmed this month.

ROWLAND TO SUB FOR HEIDFELD

Formula Renault 3.5 champion Oliver Rowland will substitute for the injured Nick Heidfeld at Mahindra Racing in the forthcoming Formula E round in Punta del Este. Heidfeld is recovering from minor hand surgery.

FF CORSE FERRARI TO NEW GT3 LM CUP

The FF Corse Ferrari squad will graduate to the new Michelin GT3 Le Mans Cup next year. It is the first team to commit to the series with a car led by Johnny Mowlem.

HITECH SIGNS ENGINEERING DEAL

New Formula 3 team Hitech Grand Prix has struck an engineering deal with AOTech, a sister company to single-seater powerhouse ART Grand Prix, to assist with its three-car European F3 campaign in 2016.

FORMULA E COULD RACE AT NORISRING

Formula E's Berlin Tempelhof round of the series, set to be cancelled because two of the airport's hangars are being used to house refugees, could be replaced by a race at the Norisring (below).



FEEDBACK

Readers' verdicts on our new look



I have been reading *Autosport* since I was seven, 58 years ago. And, quite frankly, if you slap a few pages of *Hare & Hounds*, a sheet of mouldy cardboard and half a smoked haddock between the covers, I would probably still buy it.

That said, four cheers for the return of Pit+Paddock, especially in its new mini-feature format. It was my favourite section and has been sorely missed.

Chris Hockley
Walton on Thames, Surrey

Like the new format very much. I've thought for a while that the news section was looking very sparse and could have done with more detail. I also like how the sections are arranged.

Andy Slater
Maltby, South Yorkshire

I wanted to say that I really like what you have done with regards to the new look. As someone who appreciates photography I feel the new layout allows the photos to stand out more, especially

the stunning photo of Sebastien Ogier at the start of the WRC review.

Chris Peck
By email

Autosport has really become much more reader friendly, much more logical in its layout and much more enjoyable as a result. The typeface is better for the headers too. Spot on!

Stuart Dow
By email

Well you've certainly done a Renault on the magazine – new spec, updated, and a lot worse than before. If it isn't broken, don't fix it.

Maurice Spencer
By email

The new-look magazine is a bit of a mess. The old layout was a much better look. The magazine should be more of a results archive with proper race reports where the results are with the report and not stuck on their own. Again there

F1 fans' voices are not being listened to regarding tyres, says reader John Fox

need to be clearly defined sections, rather than a jumbled mess. F1 reports shouldn't be at the front, they should be with the other races in the middle.

Simon Topham
By email

I don't like the new format. I particularly liked the short, sharp news items, not the longer versions now being used.

Ian Dunbobb
Billericay

Listen to the fans

I see Pirelli are working on an ultra-soft tyre, wanting tyres that "fall off a cliff". In the 2015 fans survey, 63.3 per cent were in favour of more-durable tyres and 52.3 per cent thought the rule requiring two specifications of tyre to be used in each race should be dropped. Clearly, no one is listening to the fans.

John Fox
East Bridgford, Notts

Correction

Ref the LAT photo on pages 88-89. I think you will find there is a bit of a hiccup with both the place and the image. I am pretty sure the car is not an MG but in fact a Gordini Type 21S.

It is the number 32 car of Maurice Trintignant/Robert Manzon which had a head gasket go on lap 34 of the 1950 Le Mans 24 hours. The MG was car 39, not 32. Please tell LAT they are wrong.

Roy Smith
By email

HAVE YOUR SAY, GET IN TOUCH

Autosport editorial
Bridge House
69 London Road
Twickenham
TW1 3SP

@
By email
autosport@
haymarket.com

Twitter
twitter.com/
autosport

f
Facebook
facebook.com/
autosport



Saving the monster

Formula 1 might be a cantankerous behemoth with a voracious appetite, but its custodians owe it a duty of care

By Ben Anderson, Grand Prix Editor

[@BenAndersonAuto](#)

MANY PEOPLE DON'T BELIEVE IN MONSTERS, BUT they should, because roughly every two weeks for most of the year one rears its ugly head in front of millions of people.

This monster is out of control in many ways. It is bloated, introspective, muddled, frustrated. And you should see its teeth! It's a frightening thing to behold at times, and there's no doubt it has scared many people away, possibly for good.

Rather like Frankenstein's monster, this one could thrive in ordinary society if treated well, but it is sorely misunderstood by large sections of the general public, who shun it rather than seek to get to know it. In the meantime, many of the familiar vices of humanity – greed, self-interest, vanity and ego – prevent those who created the monster from properly safeguarding its welfare. It was once genteel, but now the monster has grown ugly and vicious.

Some blame the zookeeper, who has ultimate responsibility for everyone's safety and wellbeing, but long ago sold rights to ownership of the animal, so perhaps feels less inclined to act. In any case they are often distracted by other projects.

Others blame the ringmaster, who saw the potential of this monster to become a global entertainment attraction, and negotiated a deal with the zookeeper to take it out on an expanded travelling circus, but in so doing created a runaway train of financial greed.

As the monster grew bigger, so the ringmaster spent larger sums of money on trainers and handlers, who wished to showcase their skills and compete to be the main act. As competition between their acts became more intense, they employed ever-greater numbers of smart thinkers to develop outlandish tricks to keep themselves in the spotlight.

To stay one step ahead of the opposition, the handlers and trainers had to source and spend ludicrous sums of their own, and hire great numbers of people. Those acts that couldn't keep up were chewed up and spat out by the monster. Well, it is a monster after all, so you must handle with care...

The zookeeper realised things were getting dangerously out of hand, so built new cages to contain the monster, but the intelligent people employed by the trainers and handlers found clever ways to open them back up.

Eventually, the public began to grow weary of the circus act and stopped watching. They felt it had become too predictable, and more about the handlers and trainers (and their clever tricksters) than the monster and the circus act itself.

The zookeeper and ringleader met with the trainers and handlers to discuss what to do, but the handlers and trainers decided it would be best if their inventors simply conjured smarter tricks to make the act more entertaining.

But some people saw through this and grew wearier. Others found alternative occupations for their time and money, so they stopped watching. Now the zookeeper, ringmaster, trainers and handlers are in a panic about what to do.

Some think the zookeeper should do away with the cage altogether and let the monster roam free again, like it used to in more innocent times, but the zookeeper is concerned about public safety. Others think the ringmaster should redistribute the massive income the monster still brings in, to allow the lesser acts to spend money on becoming more entertaining, and add greater variety to the circus. But the ringmaster answers to shareholders, who aren't so keen.

Some of the acts are so unhappy with this injustice they have asked the government to investigate. They've lost limbs to the monster over the years and want equal recompense to the other performers.

One of the main acts has repeatedly threatened to quit altogether, because it believes some of the other trainers and handlers are hogging the limelight, and turning it into a bit-part performer.

But people are generally unsympathetic, because they feel this is exactly how that act used to behave in the past...

There are two particular ways of treating the monster that made it more spectacular for a while, but have arguably combined to ruin it. One is a special suit that allows the monster to perform with greater dexterity and speed, but renders the act predictable, while the other is a more recent and expensive form of feed, which allows the monster to perform more efficiently but has arguably dulled a significant part of its raw, animalistic appeal.

Entire industries have grown up around these innovations, so no one wants to risk the massive job losses that would occur by disrupting the status quo.

Meanwhile, the monster grows more furious. Confused, angry, afraid, mistreated. Be warned, if things go on as they are, more people will be eaten.

Eventually, the monster will run out of sustenance altogether. It will slowly wilt and die, or it will be shot and killed by poachers, and those still in charge of its care will be left to feast on nothing but a corpse. ❄

“Those acts that couldn't keep up were chewed up and spat out”



Finding the next F1

Elizabeth Thompson became the first winner of the new *Autosport* Engineer of the

The drivers are the stars of motorsport, but it takes hundreds of dedicated people to produce a successful grand prix car. That's why the *Autosport* Williams Engineer of the Future Award, presented for the first time at Sunday Night's *Autosport* Awards, was created.

Elizabeth Thompson, an Oxford University student currently studying for a Masters in engineering science, is the inaugural winner and will take up her prize of a two-year placement at Williams F1 next year. Having emerged as a worthy winner

from an intensive process that culminated in a five-candidate final, fought out over two days at Williams, Thompson was delighted not just to have earned a career-making opportunity but also to have played her part in highlighting the contribution those outside the car make to motorsport.

"It's great that this is recognised at an event like this," said Thompson. "In the past, the drivers have been the focus. The subject of engineers of the future is very close to my heart and winning this is a chance to advertise F1 engineering as something that is attainable. In the engineering world, same as

in driving, it can almost be seen as an unattainable dream so it's important to show you can do it."

The candidates were drawn from the top universities for engineering in the country, and whittled down to five. Callum Frith, Andrew Lightbody, James Nurse and Oisín Scolarid were the other finalists, all facing an intensive evaluation involving both individual and group tasks. To add to the pressure, the judges – Williams chief technical officer Pat Symonds, former Jaguar F1 team boss Tony Purnell, Williams HR director Nicola Slater and this writer – were watching every step of the way.

"I really enjoyed each stage," said Thompson. "Writing the essay was really interesting and involved quite a bit of research and the two days at Williams were great. I particularly loved the exercise where we looked at broken parts."

That test involved all five, under the direction of Symonds, attempting to diagnose the cause of various parts failures. No easy task, but it allowed not only for the candidates to show their individual abilities but also how they operated in a group dynamic. This was particularly important given that, in Symonds's words, Williams is looking for someone who will



The finalists (left to right): Oisín Scolard, Andrew Lightbody, Elizabeth Thompson, James Nurse, and Callum Frith

engineers

Future award on Sunday night. By Edd Straw

“one day be able to take my job.” Symonds will mentor the winner during her two years at Williams. Even during the evaluations it was possible for Thompson to get a feel for the kind of environment the team creates to enable people to produce their best work. “It just felt very welcoming,” she said. “It felt like they were encouraging you to do the best you possibly could do rather than challenging people to get something wrong. It’s about fostering people’s skills and getting the most out of them. I got a feel for the atmosphere of Williams, and that was key.”

Thompson also paid tribute to the standard of the opposition she was up against. The judges unanimously saw all five candidates as having very bright futures in engineering, and prevailing against such strong competition was all the more rewarding for Thompson. “It’s a huge shock,” she said. “It’s such an honour to win in this company. The four other candidates are so talented, and to win amongst those four people in particular makes it mean even more.” There’s no doubt this is the start of something big, for Thompson (remember the name) and also for this new award. ✽





GRIFTHS/LAT



WARNER/LAT



GRIFTHS/LAT

AUTOSPORT *Awards 2015*

When you gather a constellation of motorsport's shining lights in one London hotel to recognise the stars of the season, you realise how vibrant this great sport really is.

At every table there might be a world champion like Jackie Stewart, Damon Hill or John Surtees, a current Formula 1 driver like Max Verstappen, Carlos Sainz or Nico Hulkenberg, or an illustrious team boss like Eric Boullier or Claire Williams. Throughout the room, the leaders of the industry assemble to honour the cars and drivers of 2015 – as voted for by readers of *Autosport*.

Alan Jones, world champion in 1980, stole the show

when he accepted his Gregor Grant Award for lifetime achievement. After being presented with his award by compatriot Mark Webber, Jones drew laughter and applause by describing today's F1 drivers as "a bit precious", raising a smile from current Williams driver Felipe Massa, who was seated at the same table!

But it wasn't just about F1, for Porsche's return to winning ways at Le Mans was honoured by Hulkenberg also receiving a Gregor Grant for his crossover win, with the Porsche 919 also receiving an award.

As always, the McLaren Autosport BRDC Award provided the evening's climax, with Will Palmer the latest name to be added to the illustrious roll of honour.



MAUGER/LAT

PRESENTED BY 



In association with Mercedes-Benz

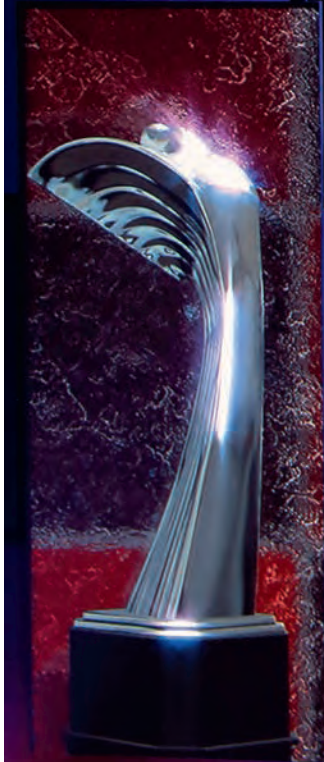

LEWIS HAMILTON

INTERNATIONAL RACING DRIVER ROLL OF HONOUR

- 1982 Keke Rosberg
- 1983 Nelson Piquet
- 1984 Niki Lauda
- 1985 Alain Prost
- 1986 Nigel Mansell
- 1987 Nigel Mansell
- 1988 Ayrton Senna
- 1989 Jean Alesi
- 1990 Ayrton Senna
- 1991 Ayrton Senna
- 1992 Nigel Mansell
- 1993 Nigel Mansell
- 1994 Damon Hill
- 1995 Michael Schumacher
- 1996 Damon Hill
- 1997 Jacques Villeneuve
- 1998 Mika Hakkinen
- 1999 Mika Hakkinen
- 2000 Michael Schumacher
- 2001 Michael Schumacher
- 2002 Michael Schumacher
- 2003 Juan Pablo Montoya
- 2004 Jenson Button
- 2005 Kimi Raikkonen
- 2006 Fernando Alonso
- 2007 Lewis Hamilton
- 2008 Lewis Hamilton
- 2009 Jenson Button
- 2010 Sebastian Vettel
- 2011 Sebastian Vettel
- 2012 Sebastian Vettel
- 2013 Sebastian Vettel
- 2014 Lewis Hamilton
- 2015 Lewis Hamilton

INTERNATIONAL RACING DRIVER OF THE YEAR

Lewis Hamilton

LEWIS HAMILTON MOVES IN RAREFIED CIRCLES these days, having become a global celebrity figure as well as a triple world champion of Formula 1.

We've learned this season that Hamilton enjoys a good party with his celebrity mates when he's not tearing it up on the race track, but the British ace decided to forego the booze and banter of this year's *Autosport* Awards.

Hamilton saw off competition from F1 rivals Nico Rosberg and Sebastian Vettel, IndyCar champion Scott Dixon, Indy 500 winner Juan Pablo Montoya and GP2 dominator Stoffel Vandoorne to win our readers' poll, but Mercedes F1 team boss Toto Wolff came to the stage to collect the gong on his driver's behalf.

"Lewis would have loved to be here, but we understand

he has a long-standing engagement in Washington DC," said compere Steve Ryder. "Do you know anything about this?" "Yeah, I think he's meeting Obama," replied Wolff. "At least that's what he told us..."

It wasn't possible to arrange a live video link to the presidential suite in the White House, so we had to make do with a pre-recorded message of gratitude instead.

"It's a great thing when it's the public [voting] and not just a panel of judges," said Hamilton of his fourth career victory in this category. "There are a lot of readers of *Autosport*, including myself, so to think I was on the back pages at one stage, in karting, and now on the front pages, and that people admire or at least appreciate the work I do is a great, great feeling. I'm very grateful."





Official government fuel consumption figures in mpg (l/100km) for the new Mercedes-AMG C 63 Coupé:
Official EU-regulated test data are provided for comparison purposes and actual performance will depend on driving style, road conditions and other non-technical factors.

It's never too late to not grow up.

The new Mercedes-AMG C 63 Coupé.





urban 24.8 (11.4), extra urban 40.9 (6.9), combined 32.8 (8.6). CO₂ emissions: 209-200 g/km.





ENGINEERED TO EXCITE

P ZERO™



POWER IS NOTHING WITHOUT CONTROL

TECHNOLOGY
DESIGNED WITH
THE BEST CAR
MAKERS TO
ENHANCE THE
PERFORMANCE
OF YOUR CAR.



ROOKIE OF THE YEAR

Max Verstappen

MAX VERSTAPPEN MADE IT FOUR TROPHIES IN three days as he added the Rookie of the Year title bestowed on him by *Autosport* readers to his three trophies from the FIA's prizegiving gala.

Red Bull pounced on the teenager last year and fast-tracked him into F1 after just one car-racing season. He has been consistently impressive, scoring points on only his second start in Malaysia and taking other opportunities whenever they presented themselves, including fourth places in Hungary and the United States. He didn't get frustrated by the poor reliability that hampered the early part of his campaign, and he finished the year as top rookie in 12th in the drivers' standings.

"I couldn't have imagined I'd have four trophies at the end of my first season, so it's definitely a surprise," said Verstappen. "I want to win trophies for championships, of course, but this is a good start."

Racer-turned-commentator Martin Brundle gave Verstappen his award and said: "He has really lit up the Formula 1 tracks this year, and given us so much to talk about. I think I said he'll be in the world-championship winning car by the time he's 20... I might have to revise that age downwards."

It's been Verstappen's racecraft and innovative overtaking manoeuvres that have made him stand out. "It's very difficult to explain how you do it – you see the gap and you go for it," he said.

"Definitely if you look at the one from Spa, it was very risky, but with the top speed we had this year, I had to try to overtake in the corners."



GRIFFITHS/LAT

BRITISH COMPETITION DRIVER OF THE YEAR

Lewis Hamilton

HAMILTON'S SUBLIME CHARGE TO HIS THIRD Formula 1 world title made him the outstanding candidate to win your vote in this category.

Britain's only other three-time title winner, Sir Jackie Stewart, was among the guests at the prize-giving, listening intently as Hamilton spoke (in a pre-recorded message of thanks) about what comes next in his career.

"I feel like I'm at a discovery point," said Hamilton. "I've just signed a three-year deal, and I'm trying to set myself some goals now."

"Naturally I'm going to get in the car next year and want to win, but how I do it, and how I continue to grow and mould and shape the way I am as a driver, and as a human being, that's unknown."



WARNER/LAT

Hamilton talked of setting new goals





How can we win three in a row?

What do we have to change?
Can we stay focused as a team?

Congratulations to Lewis Hamilton and all of the MERCEDES AMG PETRONAS Formula One™ Team.

**For some of life's questions, you're not alone.
Together we can find an answer.**



© UBS 2015. The key symbol and UBS are among the registered and unregistered trademarks of UBS.
The F1 FORMULA 1 logo, F1, FORMULA 1, FIA FORMULA ONE WORLD CHAMPIONSHIP, GRAND PRIX and related marks are trade marks of Formula One Licensing BV, a Formula One group company. All rights reserved.



NATIONAL DRIVER OF THE YEAR

Gordon Shedden

“THIS IS MEGA, BECAUSE AUTOSPORT IS THE bible!” That was Gordon Shedden’s reaction immediately after his second win in this category, which, like his first, was earned in the wake of a British Touring Car Championship title. “The enthusiasts probably know more about my racing than I do!” he continued, “so to get that public vote’s just incredible. It was great to win a second championship – it puts me the same as John Cleland, and he was the reason I got into touring cars [as an inspiration].”

This is the seventh consecutive year in which this Award has been won by the BTCC champion. “It shows that it’s popular, doesn’t it?” said Shedden. “The BTCC is on the crest of a wave, and the competition’s coming thick and fast.”

While the Jason Plato–Matt Neal rivalry is the most infamous in the BTCC, Shedden feels that the public spreads its love throughout the field: “Now there are more groups of fans who are supporting different drivers and different teams. It’s great. And for me in a race at Knockhill... it’s like that 12th man on a football field. The buzz and the energy it gives is great.”

Talking of buzz and energy, that finale at Brands Hatch really boosted the BTCC’s appeal: “Thirty races in a season, and four laps from home it’s still not ultimately decided – that’s pretty cool. The amount of letters and emails we got afterwards was like, wow – how amazing is touring cars? And it was a great advert for the sport. It got everyone on the edge of their seats and that’s what motorsport is about, isn’t it?”



GRIFFITHS/LAT

BRITISH CLUB DRIVER OF THE YEAR

Will Palmer

THIRTY-TWO YEARS SINCE HIS FATHER JONATHAN received an Autosport Awards gong as British Competition Driver of the Year, after earning the public’s approval for his dominant 1983 European Formula 2 Championship season with the Ralt-Honda, Will Palmer similarly gained the public vote for his BRDC Formula 4 success.

Perhaps significantly, it showed that his defeat of Harrison Newey captured the imagination more than F4’s rival MSA Formula series and the other TOCA supports.

“It’s amazing,” said Palmer. “I’ve been coming to the Autosport Awards for years now, and to finally be up on that stage... it’s incredible. It’s been an amazing season, I’ve had a huge amount of success, and it’s fantastic to be recognised at such a prestigious event as this.”



GRIFFITHS/LAT



WARNER/LAT

“It’s fantastic to be recognised at such a prestigious event as this”
Will Palmer



BOSE[®]

**OUR PASSION FOR BETTER
DOESN'T STOP AT
A FINISH LINE**

**BOSE and the MERCEDES AMG
PETRONAS Formula One™ Team:
What a great first year together!**

Driven by a shared passion for better, we will never stop imagining how to outperform what has come before. And we will not settle for less than our best.

From the innovators in sound to the innovators in speed, we send our congratulations – for the breathtaking finishes, and the roaring sound of success.

OFFICIAL TEAM PARTNER



AMG
PETRONAS
FORMULA ONE™ TEAM



JOHN BOLSTER AWARD

Eddie Jordan

EDDIE JORDAN WAS IN TOP FORM AS HE RECEIVED an award for his F1 team's achievements as a privateer.

First he jibed "God bless David Coulthard" for taking out Michael Schumacher and opening the way for Jordan to take its first win, seven years after its debut, in the 1998 Belgian Grand Prix. He then joked that Damon Hill, who presented the trophy and secured that win, joined the team "to increase his pension fund" before adding: "He was a revelation... Spa 1998 was fantastic."

So what does he think of modern F1? "I don't like what is going on," he said. "With due respect to Ferrari and Mercedes, they have far too much control. Give the control back to the people, who love the independent teams as they are the lifeblood of our sport."



GRIFFITHS/LAT

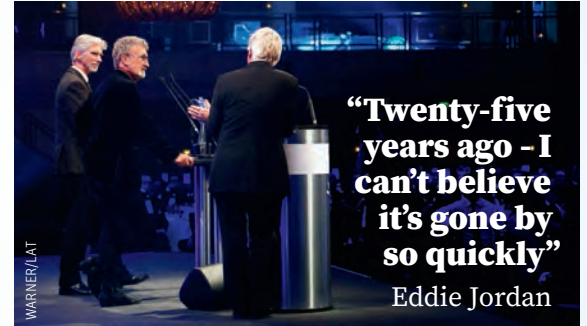

JOHN BOLSTER AWARD

Porsche Motorsport

PORSCHE ADDED TO ITS BULGING COLLECTION of silverware from the 2015 season on Sunday night. A historic Le Mans 24 Hours victory, the World Endurance Championship manufacturers' title and the drivers' crown for Mark Webber, Timo Bernhard and Brendon Hartley were recognised with the John Bolster Award.

"I don't think anyone predicted that we would be that successful in our second season back, even though we are Porsche and expectations are always high," said LMP1 technical director Alex Hitzinger, who led the Porsche 919 Hybrid design team.

"Le Mans was always the target in 2015, but to come away with two championships was unbelievable.

"We knew what was coming with the high-downforce car for the second half of the season, and I said to the team after Le Mans that there was no reason why we couldn't win every race over the rest of the year. It was a bold statement."

The second iteration of the 919 Hybrid did win each of the last five races, bringing its season's tally to six. It also maintained an unprecedented monopoly in qualifying in all eight WEC races in 2015.

"This prize is more recognition for everyone involved in the project," said Hitzinger, who was presented with the award by the 1991 Le Mans winner Johnny Herbert.

It is fitting that the achievements of the 919 Hybrid should be recognised with the John Bolster Award. Autosport's technical editor for more than 30 years would have been intrigued by the technology behind this phenomenally successful racing car.



GRIFFITHS/LAT



OUR STRONGEST OIL IS NOW TITANIUM STRONG



BOOSTED WITH
TITANIUM FST™

Castrol EDGE now boosted with **TITANIUM FST™** is our strongest and most advanced range of engine oils yet. **TITANIUM FST™** doubles its film strength, preventing oil film breakdown and reducing friction. So you can be sure your engine will respond how you want, when you want.

Castrol EDGE with **TITANIUM FST™**: strength for maximum performance.



IT'S MORE THAN JUST OIL. IT'S LIQUID ENGINEERING.



www.castroledge.com



GREGOR GRANT AWARD

Nico Hulkenberg

IT WAS TOUGH BEING REMINDED THAT HE HAD not won a race for six years before this year's Le Mans triumph, but Nico Hulkenberg took it in his stride as he collected a Gregor Grant award.

Hulkenberg became the first active Formula 1 driver to win the 24-hour classic for 24 years when he took the honours with Earl Bamber and Nick Tandy for Porsche in June. Speaking about his achievement, the Force India driver said: "Winning Le Mans is the biggest achievement of my career so far.

"That whole weekend was incredible. To come in there, not really expecting much, and to win with Porsche was phenomenal."

For a driver to claim a win at any level is a memorable achievement for them, but for Hulkenberg, to win such an iconic event is unforgettable, and something he can learn from.

"It's more about Le Mans and what it really means to so many people on this planet. It's such a special and unique race," he said.

"To be there for the first time, to feel and breathe in the atmosphere, to be part of it, and to win it, to be able to drive the start and to take the car to the start was all very special. They're memories I'll carry for the rest of my life."

And as for the level of interest it sparked from his fellow F1 drivers, he said: "There was a very positive echo from winning Le Mans.

"A lot of drivers were curious and asking me about it, even beforehand. But after winning it everybody was asking me more. They're keeping an eye on it."



GRIFFITHS/LAT

AUTOSPORT WILLIAMS ENGINEER OF THE FUTURE

Elizabeth Thompson

THE AUTOSPORT WILLIAMS ENGINEER OF THE Future Award was presented for the first time, with Elizabeth Thompson winning the career-making chance to work for one of the most respected grand prix teams in history for two years.

Thompson, who will complete her Masters in Engineering Science at Oxford University before joining Williams, prevailed against tough competition to convince the judges – Williams chief technical officer Pat Symonds, former Jaguar F1 team principal Tony Purnell, Williams HR director Nicola Slater and Autosport's Edd Straw – that she was the best candidate.



GRIFFITHS/LAT



"Elizabeth will learn so much"
Claire Williams

S BLOXHAM/LAT

P80 WILLIAMS ENGINEERING AWARD



- Formula One
- Le Mans 24hr
- WEC - SPA - Nurburgring - Sakhir

TOUR PACKAGES

DESTINATIONS



FORMULA ONE WINTER TESTING	BARCELONA	Pit Lane Hospitality Team Packages
FORMULA ONE 2016	ALL GRAND PRIX	UK Tour Travel Team Escorted Tours By-Air with Holiday options
FORMULA ONE COACH TOURS	SPAIN, MONACO, AUSTRIA, GREAT BRITAIN, HUNGARY, GERMANY, BELGIUM, ITALY	Escorted Holiday Tours Executive Coach Travel
LE MANS / WEC-6HR	LE MANS 24HR, SPA & NURBURGRING 6HR SAKHIR, Bahrain	By-Air, Coach Tours Self Drive By Air Packages
HISTORIC EVENTS	MONACO HISTORIC MILLE MIGLIA GOODWOOD FESTIVAL LE MANS CLASSIC GOODWOOD REVIVAL	Escorted Tour Package By-Air Coach Tours Self Drive

- Mille Miglia
- Le Mans Classic
- Monaco Historic
- Goodwood



SPONSORSHIP OPPORTUNITIES

SUPPORT MATT PARRY
GP3 DRIVER

CONTACT MATT AND JOIN
HIM TRACKSIDE

WWW.MATTPARRYRACING.CO.UK



UK TRAVEL TEAM: +44 (0) 1451 833 721
BOOK ONLINE: enquiry@selectmotorracing.com





GREGOR GRANT AWARD

Alan Jones

THIRTY-FIVE YEARS AFTER ALAN JONES GAVE Williams its first world championship, the Australian made his debut appearance at the *Autosport Awards* and was presented with the Gregor Grant Award by fellow countryman Mark Webber.

Jones was renowned for his no-nonsense style of racing. "In my day, if somebody did something wrong you'd rub wheels with them and get even," he joked.

After spells with Graham Hill's and John Surtees's teams, he joined Shadow and clinched a shock maiden win in the 1977 Austrian GP.

He joined Williams the following year, forming a highly successful alliance with Sir Frank Williams and Patrick Head that yielded 11 wins, the 1980 title and third-place finishes in '79 and '81.

"I was very fortunate to join Williams, the best team I've ever driven for," Jones said. "They gave me a car that enabled me to do the job. Frank is the best guy I ever drove for and Patrick was the best engineer of his day.

"I had some great races, some of which I didn't necessarily win. I was proud of the way I raced. That was really important to me. You don't have to win, but if you've done a really good race, that's so important."

"I'm extremely honoured to be here to receive this, because I know there have been some very famous people who have won this award"

Alan Jones



GRIFFITHS/LAT

AUDIENCE

Stars of racing shine at *Autosport Awards*

The *Autosport Awards* isn't just about those who appear on stage to receive the prizes. During the evening, Henry Hope-Frost and his roving microphone picked out some of the other stars of motorsport.

Among those who were interviewed in The Great Room were Le Mans 24 Hours victor Nick Tandy, GP2 champion Stoffel Vandoorne and Formula Renault 3.5 title winner Oliver Rowland. Jackie Stewart and World Endurance Champion

Mark Webber played their parts too. Among those presenting awards were Felipe Massa, Martin Brundle, Derek Warwick, Jonathan Neale, Toto Wolff, Johnny Herbert and Webber.

Just as remarkable were those there was no time to interview: Jolyon Palmer, Carlos Sainz (both junior and senior), Stirling Moss, John Surtees, Jose Maria Lopez, Timo Bernhard, Brendon Hartley and Eric Boullier were some of the big names also attending.



Moss, Stewart and Chandhok among famous attendees

WARNER/LAT



Come see us at
Autosport 14-17 January,
Stand 8230, NEC

DELIVERING PRECISION ENGINEERING

WITH EXCEPTIONAL SERVICE



Our innovative design and precision engineering makes us your perfect Motorsport partner.

Our engineers are committed to high quality manufacture and assembly, delivered to exacting standards with world class service.

Contact us to see how we can engineer your competitive advantage.

T. +44 (0) 1480 474402
sales@titan.uk.net

www.titan.uk.net



Dynamic Engineering



RACING CAR OF THE YEAR

Mercedes F1 W06 Hybrid

PRESENTED BY

IT IS HARD TO IMPROVE ON SOMETHING MANY perceive as flawless, but Mercedes managed to achieve exactly that in 2015 with the F1 W06 Hybrid.

Mercedes again scored 18 poles and 16 wins in '15, as the team did in '14, en route to winning the drivers' and constructors' double.

This season, however, the team claimed a new Formula 1 record of 12 one-two finishes, and, with 703 points, finished two better off than in '14.

The level of dominance has been staggering, to which engineering director Aldo Costa said: "We wanted to demonstrate we were able to win a second time, and win multiple championships.

"All the people within the team set a very difficult target of achieving in all areas.

"We achieved almost everything we wanted to achieve, putting together a car that was a good enough step to win the championship."

With Ferrari coming on strong in '15, Costa knows it will likely pose an even stronger threat in '16, ensuring Mercedes will need to raise its game again.

"They [Ferrari] made quite a bit of progress compared to last year," added Costa, who collected the award along with performance director Mark Ellis, head of aerodynamics Mike Elliott and chief designer John Owen, plus head of performance engineering Owen Jones and engineering director Hywel Thomas from engine arm Mercedes High Performance Powertrains

"We know we have a strong competitor, so we have again set a very good target for next year, and for sure we will fight up until the last race."



GRIFFITHS/LAT

PIONEERING AND INNOVATION

McLaren Applied Technologies

DID YOU KNOW THAT PRODUCTS OF McLAREN Applied Technology feature on every single Formula 1 car, IndyCar and NASCAR? The work of MAT (formed in 1991) also covers sectors as diverse as healthcare, financial services, air traffic control and designing Lizzie Yarnold's Olympics gold medal-winning skeleton bob.

"We are really lucky to have so many good engineers in F1," said technical director Caroline Hargrove (right). "To be able to apply that in healthcare, rail, financial services shows we can give something back.

"We are doing some really interesting work in surgical simulations and telemetry, which we have done on racing cars for years, on people. We've been able to have an impact on people's lives."



GRIFFITHS/LAT



Lizzie Yarnold won Olympic gold with help of MAT

WANG SONG/REX SHUTTERSTOCK



PROGRESS. From the base up.

We sweat the small stuff
so you don't have to.

NASA approved temperature regulation reacts quickly to reduce perspiration by up to 30% when the heat is on, and delivers warmth when it's not. Antimicrobial technology keeps you fresh and superior tailoring helps you maintain concentration.

Introducing Walero. Race ready advanced base layers.

Get The Edge

www.walero.uk

FIA 8856-2000 & SFI 3.3 approved





RALLY DRIVER OF THE YEAR

Sebastien Ogier

Family commitments kept Sebastien Ogier away from the Awards for the first time in three years on Sunday evening – but he was still a very grateful recipient of the Rally Driver of the Year Award.

Readers recognised another outstanding season for the Frenchman, who won eight of the 13 rounds and secured the title with three rallies to spare.

“I’m really sorry to miss the *Autosport* Awards,” Ogier said. “It’s always a really special and cool night with some incredible names from all around the sport. It’s an honour to win this award from the readers of *Autosport* – I was a little worried this year that I might lose it to Kris [Meeke]! I really want to say thank you again for this. It’s special.”



RALLY CAR OF THE YEAR

Volkswagen Polo R WRC

TWELVE WINS FROM 13 STARTS for the second season in succession marked Volkswagen’s Polo R WRC out as the car to beat in world rallying in 2015. It was also good enough to secure *Autosport*’s Rally Car of the Year Award.

No manufacturer in the history of the World Rally Championship has managed the level of dominance the Hannover team has attained. The most astonishing aspect (not to mention most worrying for its rivals) is that this is only Volkswagen’s third year running a World Rally Car at the sport’s highest level.

Had it not been for the faulty batch of fuel injectors that halted Sebastien Ogier and Jari-Matti Latvala in Argentina, the Polo would more than likely have been celebrating the perfect season.

Team principal Jost Capito admitted his season had brought both delight and relief.

Capito said: “In the face of some incredible competition and across some of world’s toughest roads, to manage success like this is a fantastic achievement for everybody in the whole of the Volkswagen Motorsport team.

“Every year you set out with the championship as your target, but another target was to make everything right with Rally Germany. In the first year, things didn’t go well at home. At the start of last year, we promised we would put it right – but it went wrong again. Finally, it was a relief to get it right.

“And to come here tonight to accept this award is a really proud moment. Everybody knows how important *Autosport* magazine is in our industry, so this is a big one for us!”





Congratulations **Will Palmer**

McLAREN AUTOSPORT BRDC AWARD WINNER 2015

Thank you

McLaren, Autosport and the BRDC gratefully acknowledge the support of the following:
Arai, Base Performance Simulators, Grand Prix Racewear, McLaren Automotive, McLaren GT, Mercedes-Benz, MotorSport Vision, Porsche Human Performance Centre, Pirelli, Silverstone Circuit, Sparco, Timing Solutions Ltd

The McLaren Autosport BRDC Award judging panel:
Andrew Kirkaldy, Scott Mitchell, Jason Plato, Ian Titchmarsh, Kevin Turner, Mark Williams
Chairman of the judges:
Derek Warwick





McLAREN AUTOSPORT BRDC AWARD WINNER 2015

Will Palmer

SON OF JONATHAN. BROTHER OF JOLYON. IT'S NOT been easy for Will Palmer to overcome family affiliation. But the 18-year-old deserves to be viewed as a genuinely talented young driver with the intelligence and the ability to make a career in motorsport.

Sunday night will not be the last time that Jonathan Palmer receives his son's gratitude. But emerging from the shadow of a famous family name is a great personal burden for any young driver.

"My family has a long history in motorsport and, with my brother being in Formula 1 next year, it's easy for me to maybe look like just the brother of Jolyon Palmer," says Will. "Instead, this Award is huge in making it clear I'm a driver in my own right. I'm trying as hard as I can to get to F1 as well. Hopefully this is a big step in getting there one day."

Palmer's a rarity among modern young drivers: he's not done any serious amount of karting. Ginetta Juniors were his first real foray into motor racing, and he's been on a steep learning curve since. It would have been truly harsh had people written him off in 2012 after a first full season that yielded 12th in the points.

In his second full campaign Palmer took his first win,



and wound up third in the points. A switch to single-seaters beckoned, and he took two victories in the BRDC Formula 4 Winter Series before graduating to the full series for 2014, in which he won twice again and finished sixth in the points.

Palmer, by this stage, had proven capable of searing pace. But racecraft, arguably the single greatest skill learned in karting, was lacking. There were too many incidents and a large slice of bad luck. So it was back to the Winter Series, which he won, and then a return to the main championship for 2015 for a crack at the title.

He didn't disappoint, crushing his opposition with 12 wins from 24 races and clinching the crown a round early. That was complemented by a competitive showing on his two-litre Formula Renault debut in the Eurocup at Silverstone, and since the end of the campaign he has tested Formula 3 and GP3 machinery.

Where Palmer goes next, he's not sure. But he knows where he wants to be, and what becoming the 27th McLaren Autosport BRDC Award winner could mean.



CV

WILL PALMER

2015 BRDC F4 champion (HHC Motorsport)
12 wins, 15 podiums, 10 poles

2014 6th BRDC F4 (HHC)
2 wins, 7 podiums, 1 pole
BRDC F4 Winter Series champion (HHC)
4 wins, 7 podiums

2013 3rd Ginetta Junior (HHC)
1 win, 10 podiums, 4 poles
5th BRDC F4 Winter Series (HHC)
1 win, 1 pole

2012 12th Ginetta Junior (HHC)

McLAREN AUTOSPORT BRDC AWARD

ROLL OF HONOUR

- 1989 David Coulthard
- 1990 Gareth Rees
- 1991 Oliver Gavin
- 1992 Dario Franchitti
- 1993 Ralph Firman Jr
- 1994 Jamie Davies
- 1995 Jonny Kane
- 1996 Darren Turner
- 1997 Andrew Kirkaldy
- 1998 Jenson Button
- 1999 Gary Paffett
- 2000 Anthony Davidson
- 2001 Steven Kane
- 2002 Jamie Green
- 2003 Alex Lloyd
- 2004 Paul di Resta
- 2005 Oliver Jarvis
- 2006 Oliver Turvey
- 2007 Stefan Wilson
- 2008 Alexander Sims
- 2009 Dean Smith
- 2010 Lewis Williamson
- 2011 Oliver Rowland
- 2012 Jake Dennis
- 2013 Matt Parry
- 2014 George Russell
- 2015 Will Palmer

THE OTHER FINALISTS



JACK AITKEN

The Formula Renault Eurocup and ALPS champion has tested in GP3 and Formula 3.5 V8 as he assesses which championship he should step into next season.

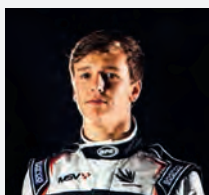

BEN BARNICOAT

Racing Steps Foundation-backed Barnicoat will move out of two-litre Renault and into Formula 3, with an announcement already about joining the crack Prema Powerteam.



RICKY COLLARD

After finishing runner-up in MSA Formula, the son of BTCC racer Rob hopes to move to continental European competition in 2016, and has tested in Formula Renault.

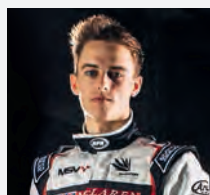

JAKE HUGHES

A car problem hobbled Hughes's Eurocup and ALPS campaign, but the Brummie has shrugged off that disappointment and performed strongly in FR3.5 and GP3 testing.

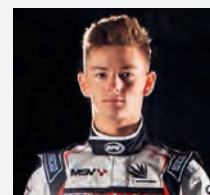

TOBY SOWERY

The future's unclear for the talented MSA Formula driver. Moving from Britain is the aim, but budget restraints may force him to look closer to home, perhaps in BRDC F4.



Thank you



British Racing Drivers' Club, Christian Marryat, Grosvenor House Hotel, Highland Spring, Mercedes-Benz, LAT Photographic, McLaren Group Ltd, Kevin Chapman, Ben Foakes, RSM, Silverstone Circuit, Steve Rider, SEAT UK, Murray Walker, Williams

Award Sponsors

Title sponsor:
Mercedes-Benz

Bahrain International Circuit, Bose UK, Castrol Edge, Pirelli, UBS

Video material kindly supplied by

ACO, BBC, Bernie Ecclestone/FOM, Brunswick Films, Daytona, Eurosport, FIA, Granada, Greenlight, Hay Fisher, IMSA, IMG, IndyCar, ISC, ITV Sport, Le Mans Series, McLaren, MotorSport Vision, MS Productions, NASCAR, Pit Lane Productions, Renault, Sky Sports, SRO, TOCA, V8 Supercars

McLaren, Autosport and the BRDC gratefully acknowledge the support of the following

Arai, Base Performance Simulators, Grand Prix Racewear, McLaren Automotive, McLaren GT, Mercedes-Benz, MotorSport Vision, Porsche Human Performance Centre, Pirelli, Silverstone Circuit, Sparco, Timing Solutions Ltd

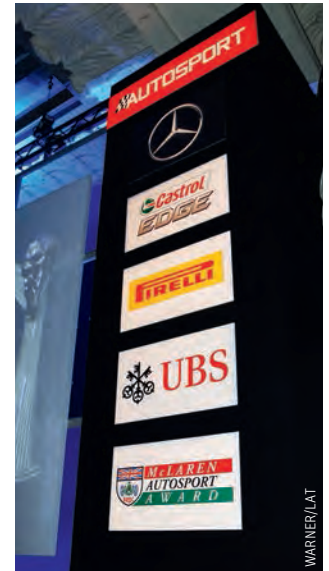



The McLaren Autosport BRDC Award judging panel
Andrew Kirkaldy, Scott Mitchell, Jason Plato, Ian Titchmarsh, Kevin Turner, Mark Williams
Chairman of the judges:
Derek Warwick

Williams and Autosport would like to thank
Unilever & the Williams Conference Centre

The Autosport Williams Engineer of the Future judging panel
Tony Purnell, Nicola Salter, Edd Straw
Chairman of the judges:
Pat Symonds

On behalf of Tommy's, the baby charity and Grand Prix Trust we would like to thank
Lewis Hamilton, Nico Rosberg & Niki Lauda for signing the limited-edition table centres and Mercedes-Benz for supplying the Mercedes-Benz CLA Shooting Brake

Autosport would like to thank
Mirage Parties for the production of the 2015 Autosport Awards. For further information on Mirage Parties, log on to www.mirageparties.co.uk

Autosport would also like to thank
Make Television for filming the McLaren Autosport BRDC Award test: www.maketelevision.co.uk





Winterbottom leads from van Gisbergen and Courtney

Winterbottom claims maiden title

V8 SUPERCARS
HOME BUSH (AUS)
DECEMBER 5-6
ROUND 14/14

AT THE END OF A LONG V8 Supercar season, Mark Winterbottom's private championship battle with Craig Lowndes ended with an actual bang, then something of a whimper at Sydney's Olympic precinct.

Winterbottom shrugged off a Friday practice crash by taking pole in his Prodrive Ford for the first of the three races but, when Lowndes hit a wall in the same qualifying

session, forcing him to start from 25th and last, the task became that much easier. While Lowndes charged his Triple Eight-run Red Bull Holden up to 15th in the race, Winterbottom cruised around to fifth, and backed that up with third (from grid four) in the second race to seal his first title. It was also Prodrive's maiden title, after more than a decade of toil.

Both races were won by Lowndes's outgoing champion team-mate Jamie Whincup, who stretched his remarkable record at the tight street circuit to five wins in seven races.

On Sunday no one could touch the Tekno Holden of Shane van Gisbergen — except James Courtney. His Holden was nudged out of the lead by 'The Giz', who then streaked away. Even when a late-race safety car set up a four-lap dash to the flag, van Gisbergen held on to win from Whincup, who lost the position to Rick Kelly when he went up an escape road before regaining it in the pits. Kelly gave Nissan a strong third place ahead of Winterbottom and Reynolds. The weekend's Holden sweep guaranteed it the makes' title ahead of Ford.

PHIL BRANAGAN

RESULTS

Race 1 1 Jamie Whincup (Holden Commodore VFII), 37 laps in 56m13.3631s; 2 Shane van Gisbergen (Holden), +1.0856s; 3 Jason Bright (Holden); 4 James Courtney (Holden); 5 Mark Winterbottom (Ford Falcon FGX); 6 Tim Slade (Holden).

Race 2 1 Whincup, 37 laps in 58m11.3197s; 2 David Reynolds (Ford), +1.8208s; 3 Winterbottom; 4 Courtney; 5 Scott McLaughlin (Volvo S60); 6 van Gisbergen.

Race 3 1 van Gisbergen, 74 laps in 1h59m24.7481s; 2 Whincup, +0.4058s; 3 Rick Kelly (Nissan Altima); 4 Winterbottom; 5 Reynolds; 6 Craig Lowndes (Holden).

Points 1 Winterbottom, 3246; 2 Lowndes, 3008; 3 Reynolds, 2910; 4 van Gisbergen, 2712; 5 Whincup, 2647; 6 Garth Tander, 2584.

Riviere ices up to top first round

ANDROS TROPHY
VAL THORENS (F)
DECEMBER 5-6
ROUND 1/7

WHEN BENJAMIN RIVIERE muscled his Citroen past the Renault of Jean-Baptiste Dubourg on the opening lap of the first final, that proved the decisive moment on who would lead the points after the 2015-16 series curtain raiser.

Dubourg won the qualifying heats and, although Riviere's race win wasn't enough to overhaul Dubourg in the overall Saturday classification, this made the difference in the standings by the end of the weekend. They were glued together again in Sunday's final, Dubourg winning the fight for fourth.

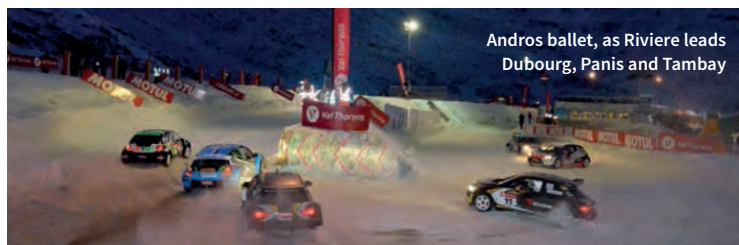

Andros ballet, as Riviere leads Dubourg, Panis and Tambay

Franck Lagorce non-started the Saturday final with engine problems on his Dacia, but bounced back to win convincingly on Sunday from Dubourg's brother Andrea. As he had on Saturday, Olivier Panis took third overall and in the final with the new WRT-run Audi A1.

Jean-Philippe Dayraut had a disaster, engine problems on his Mazda ruling him out of both finals.

RESULTS

Final 1 1 Benjamin Riviere (Citroen DS3), 8 laps in 6m36.104s; 2 Jean-Baptiste Dubourg (Renault Clio 3); 3 Olivier Panis (Audi A1 Quattro); 4 Adrien Tambay (Audi); 5 Olivier Pernaut (Citroen); 6 Andrea Dubourg (Renault). **Final 2 1 Franck Lagorce (Dacia Lodgy)**, 8 laps in 6m25.153s; 2 A Dubourg, +3.306s; 3 Panis; 4 J-B Dubourg; 5 Riviere; 6 Pernaut. **Points 1 Riviere, 107**; 2 J-B Dubourg, 106; 3 A Dubourg, 104; 4 Panis, 103; 5 Lagorce, 97; 6 Pernaut, 94.

IN BRIEF

DUNLOP V8 SUPERCARS

Cameron Waters mirrored Prodrive Ford team-mate Mark Winterbottom to win the title at the final round in Sydney. Paul Dumbrell won both races in his Holden but eighth and second places sealed the deal for Waters. Todd Hazelwood (Ford) was third overall.

AUSTRALIAN F4

Tom Randle swept all three races at the Sydney finale. The first was cut short after multiple crashes, while the second featured a charge for Randle from sixth on the grid. Jordan Lloyd, already confirmed as champion, was second overall from Will Brown.

WEB DIRECTORY

AWNINGS



No1 for Inflatable Structures.
With you from the Paddock to the Podium.
www.aireshelta.com

EXHAUSTS

Inconel & Stainless Steel Specialists
SIMPSON
Race Exhausts
Tel: 01753 532222
www.simpsonraceexhausts.com

HELMET GRAPHICS

Mike Fairholme Designs
Sole approved painter of Arai helmets.
Silver Birches, Corby Birkholme, Nr Grantham, Lincs NG33 4LE.
Tel: 01476 550630. Fax: 01476 550029.
email: fairholmedesigns@btconnect.com
www.fairholmedesigns.co.uk

RACE PARTS

ARE DRY SUMP SYSTEMS
ARMSTRONG RACE ENGINEERING INC.
WWW.DRYSUMP.COM (916) 652-5282

ENGINES

Precision machining and engineering
Leading brand replacement & performance engine parts
www.gosnays.co.uk
Tel: 01708 748320

GEARBOXES

Gearboxman.com
COMPETITION TRANSMISSION SERVICES
Gearboxes & Axles for Road, Race, Rally and more
Telephone: 01582 840008 Fax: 01582 840007

MOTOR RACING LEGAL ADVICE

Motor Sport Legal Advice
Tudor Alexander, LI.B Solicitor
tudor@fletcherday.co.uk
07887 713512

RACE RADIO

Pit to Car Autotel
Radio solutions **Digital Race Radio**
0044(0)1508 528837
www.raceradio.co.uk

EQUIPMENT

JJC race and rally
PASSIONATE ABOUT MOTORSPORT
www.jjcraceandrally.com

HELMET GRAPHICS

Visit: www.liquidcolourdesign.com
Studio: +44 028 93378525
Mob: +44 0770 9442894
liquidcolourdesign
Helmet Print | Design | Airbrush | Custom Paint

RACE PARTS

PORSCHE SHOP
10% off with website
voucher code **AUTOTEN**
Or Call: 0121 585 6088

RACING

MARDI GRAS MOTORSPORT
www.mardigras.co.uk

RACING

AUTHORISED DISTRIBUTOR
OMP **YBRACING**
MOTORSPORT & PERFORMANCE
WWW.YBRACING.COM

CARTEK
MOTORSPORT ELECTRONICS
023 80 467747
WWW.CARTEKMOTORSPORT.COM

FINAL LAP
For Everything Formula One
www.finallap.net **WE BUY AND SELL**
+44 (0) 1245 287588 / 07771 920345

RACING

demon tweeks
MOTORSPORT
www.demon-tweeks.co.uk

MANUFACTURERS OF SPORTS PROTOTYPE RACING CARS
NEW & SECOND HAND MCR'S FOR SALE
ARRIVE & DRIVE PACKAGES
MCR RACE CARS

TRAILERS & TRANSPORTERS

Signature Motorhomes Ltd
RV SALES & SERVICE 01902 725394
www.signaturerv.co.uk
www.signaturemotorhomes.com

TRAILERS & TRANSPORTERS

itchy feet
european & american motorhomes
0345 504 5550

BRIAN JAMES TRAILERS
» Connected to you
www.brianjames.co.uk

WHEELS & TYRES

Image Manufacturers of bespoke split rim alloy wheels
www.imagewheels.co.uk
IMAGE WHEELS INTERNATIONAL LTD.



TO ADVERTISE IN THE WEB DIRECTORY
PLEASE CALL **020 8267 5271**
OR EMAIL autosport.ads@haymarket.com



www.woodfordtrailers.com

HIGH QUALITY TRAILERS FOR CLUB, PRIVATE AND PRO MOTORSPORTS



Email: sales@woodfordtrailers.com

01327 263 384

BRIAN JAMES TRAILERS

» Connected to you



www.brianjames.co.uk

Enduring passion for excellence

Almost four decades since Brian James first imagined a better way to make car transporter trailers the passion for excellence runs strong.

A Brian James Trailer has always stood out from the crowd, illustrating in metal, plastic and rubber our passion for producing the finest quality, always exceeding customer expectation.

The latest Race Transporter models are testimony to the innovation and designs our dedicated engineers continue to develop.

Photographed (above), Race Transporter 5

Race Transporter range start from £ 6,750 (excl. VAT).

To find your nearest dealer visit:
www.brianjames.co.uk/dealer



T +44 (0)1327 308 833

For more information and details on the Brian James Trailers range, please contact our head office.

RACE TRANSPORTER

TRAILERS AND TRANSPORTERS

AUTOSPORT

**IF YOU'D LIKE TO ADVERTISE
YOUR PRODUCTS AND
SERVICES PLEASE CALL**

0208 267 5992

PRG TRAILERS

Finest Built British Trailers.



PRG Trailers | Cheshire | UK | Tel: +44 (0) 1270812402
Web: www.prgtrailers.co.uk | Email: info@prgtrailers.co.uk

Signature
RV.co.uk

The UK's only supplier of new 2016 Thor luxury motorhomes with full factory support

Serving the motorsport industry for over 25 years
Large selection of used vehicles • Export and USA pick up
SALES • SERVICE • PARTS • MOT

Vegas European size American features 3.6t towing capacity

Ace the UK's only A Class Rv under 7.5T full wall and double slide out floor plans

Palazzo Luxury Diesel pusher double bathrooms 340Hp cummins Diesel

Signature motorhomes Ltd
01902 725394
www.signaturerv.co.uk
www.signaturemotorhomes.com
Cannock Road, Westcroft, Wolverhampton, WV10 8QU



Ex F1 Transporter, totally refurbished, carries TWO cars or loads of bikes/karts + Awning

- ◆ Totally self sufficient
- ◆ Full length GH Awning nearly new.
- ◆ On-board diesel generator
- ◆ Large leisure area with Air Con, full cooking, large TV, seats 8 people, etc.
- ◆ 2 bunks.
- ◆ Full size shower & toilet
- ◆ Masses of locker space.
- ◆ New MOT

Ready to go!

£89,950 or sensible offers.

Tractor unit also negotiable.

David 07860 912461



CARS FOR SALE / DRIVES AVAILABLE



IF YOU'D LIKE TO ADVERTISE
YOUR PRODUCTS AND
SERVICES PLEASE CALL

0208 267 5992



FOR SALE:

2 MYGALE 2010 FORMULA 3



- 2012 aerokit
- Mercedes engine kit installation (Fiat available)
- No electronics
- Excellent condition
- Price: negotiable

For more information
+33 3 86 21 86 21
decoaster@mygale.fr



DRIVES AVAILABLE IN THE 2016 EUROPEAN LE MANS SERIES

NEW LIGIER JSP3 / LMP3 RACE WINNING TEAM IN 2015

CONTACT **NICK REYNOLDS**
TEL 0044 (0)1204 903344
MOBILE 0044 (0)7711 888901
EMAIL nick@rlmsportltd.com



www.rlmsportltd.com facebook.com/teamrlr twitter.com/TeamRLR



FOR SALE

ALAN MANN RACING MUSTANG

PAINSTAKINGLY BUILT BY ORIGINAL AMR LEAD MECHANIC, BRIAN LEWIS - THIS IS
YOUR CHANCE TO OWN A PROPERLY PREPARED AND PROVEN FIA RACE WINNER

FULL SPARES AVAILABLE • PRICE ON APPLICATION



IMAGE © JEFF BLOXHAM

CONTACT HENRY MANN FOR MORE DETAILS
+44 (0)7712 764 629 • HENRY@ALANMANN.CO.UK

ALAN MANN RACING
ESTABLISHED 1964

WWW.ALANMANN.CO.UK @ALANMANNRACING

CARS FOR SALE / DRIVES AVAILABLE

MARKETPLACE

FLOORING

Kiwi Tiles

Interlocking Plastic Floor Tiles, as used by leading race teams throughout Europe.

- Easy installation & removal
- Many colours
- Lightweight
- Strong and durable
- Compact & easy to store
- Top quality
- Value for money

Stock Colours:
Red, Blue, Green,
Yellow, Silver, Orange,
Grey, Black, White,
Dayglo Red

Ralt Engineering

Tel: 01865 883354 Fax: 01865 883789
Email: enquiries@kiwitiles.com
www.kiwitiles.com

RACE PRODUCTS

FREE



2016 CATALOGUE

516 pages of the best motorsport parts, accessories and innovative new products. Available to order now.

demon tweeks
MOTORSPORT

Online at www.demon-tweeks.co.uk Call 0906 250 1516

Calls to 0906 numbers cost 50p per minute at all times. (Calls should last no longer than 11/2 minutes).

RACE PRODUCTS

Elite Carbon Fibre

Carbon fibre race car component manufacturer

EliteCarbonFibre Ltd.
Units 20-22 Norwich Road Ind. Est.
Watton, Thetford, Norfolk IP25 6DR

Contact – Dave Greenwood 07809390316
Email – davecarbonelite@googlemail.com
Website – elitecarbonfibre.co.uk

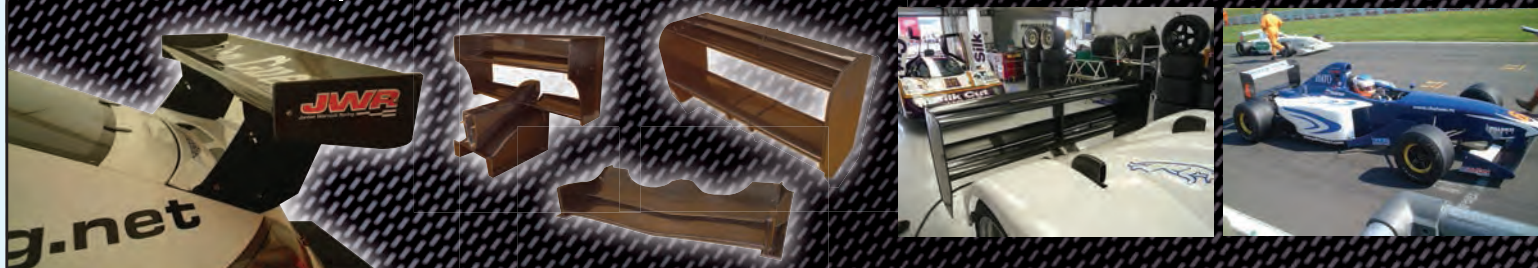

Carbon Composite Wings, Bodywork & Repairs

RACE PRODUCTS



PUMPS

High quality, reliable, quiet
Used by professionals

2 YEAR WARRANTY

OTP 017 £55.00
(P3017.1)
Replaces: Bosch 0580 464 070

OTP 018 £58.00
(P3018.1)
Replaces: Bosch 0580 254 911

OTP 019 £64.00
(P3019.1)
Replaces: Bosch 0580 254 910/941/942

'IN-TANK' FUEL PUMPS

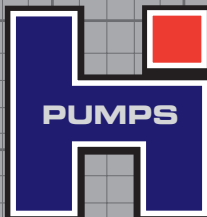

ALL PRICES EXCLUDE VAT @ 20%



MOTORSPORT

OTP 020 £65.00
(P3020.1)
Replaces: Bosch 0580 254 909



MOTORSPORT

OTP 979 £75.00
(P3979.1)
Replaces: Bosch 0580 254 979



MOTORSPORT

OTP 044 £84.00
(P3044.1)
Replaces: Bosch 0580 254 044



Tel: 01784 493 555 www.glencoeltd.co.uk Email: sales@glencoeltd.co.uk

MARKETPLACE

RACE PRODUCTS

CARTEK MOTORSPORT ELECTRONICS



Battery Isolators



Coolant Level Alarms



NEW Power Control Panels



Shift Lights



Wireless Steering Wheel Controls



FiA Rain Lights



Power Distribution Modules



Suppliers to:

- Porsche
- HWA AMG
- Ford
- KTM X-Bow
- Mini Challenge (UK)
- Kamaz
- V8 Super Cars
- Rage Motorsport

www.CARTEKMOTORSPORT.com
 CARTEK AUTOMOTIVE ELECTRONICS Ltd
 +44 (0)2380 457747 New number
 info@cartekmotorsport.com

EXPERT ADVICE • MASSIVE STOCK • RAPID DELIVERY

demon tweeks
MOTORSPORT

sparco
KIRKEY RACING FABRICATION
RECARO
RACING SEATS
TILLETT
COBRA
REVERIE
OMP

0844 375 2196
www.demon-tweeks.co.uk

MEDIA CODE: LZ252A
 LOW CALL RATE CALLS MAY BE RECORDED FOR TRAINING PURPOSES

MEMORABILIA

F1 COLLECTORS .COM

#1 FOR F1 MEMORABILIA & AUTOGRAPHS

We buy and sell F1 items
AYRTON SENNA specialists
 Call CHRIS GRINT
01763 274448
 email:- sales@f1collectors.com

TYRES

FOR ALL YOUR

AVON
TYRES
MOTORSPORT

RACING TYRES
 Inc. ACB 10 Formula Ford
 Contact

BMTR LTD

Tel: 0121 331 1122
 Fax: 0121 331 1144
 email: sales@bmtr.co.uk
 see our new website at www.bmtr.co.uk

STORAGE



SYSTEM STORE SOLUTIONS LTD

SETTING THE STANDARD IN MOTORSPORT WORKSHOP DESIGN & STORAGE



Working with teams and companies in classic/historic racing right through to Formula One.

We provide everything from single cabinets to a total design, layout and installation service, including project management, consultation, technical advice and no obligation site surveys.



- ✓ Race bays
- ✓ Machine shops
- ✓ Stand-alone workstations
- ✓ Transporters
- ✓ Mobile storage units



01622 859522 | SALES@SYSTEMSTORESOLUTIONS.COM | SYSTEM-STORE.COM

REVOLUTION

COMPETITION ▲ WHEELS



GR14 RALLY
15 X 6.0 TO 15 X 7.0



MILLENNIUM RALLY
15 X 7.0 TO 15 X 8.0 / 16 X 5.5 TO 16 X 8.0
17 X 7.5 TO 17 X 8.0 / 18 X 8.0 TO 18 X 9.0



MILLENNIUM II RALLY
FLOW-FORMED
18 X 8.0



4 SPOKE RACE
13 X 5.5 TO 13 X 10.0



4 SPOKE RALLY
13 X 5.5 TO 13 X 10.0



5 SPOKE RALLY
15 X 5.5 TO 15 X 9.0



RFX RALLY
13 X 5.5 TO 13 X 6.0 / 14 X 5.5 TO 14 X 6.0



8 SPOKE RALLY
13 X 6.0 TO 13 X 9.0 / 15 X 5.0 TO 15 X 10.0

For more information contact:

TEL +44 (0) 1623 860000 • **FAX** +44 (0) 1623 860165 • **MOB** +44 (0) 7702 845264

www.revolutionwheels.com • **info@rwil.org.uk**

MOTORSPORT JOBS

AUTOSPORT

Want to advertise a motorsport job?
If you are recruiting in motorsport and wish to advertise with Autosport in print and online please contact Jamie.brooker@haymarket.com by email or call **020 8267 5271**.

For all current vacancies advertised please visit our website www.autosport.com



Manor F1™ Team are seeking smart, creative team players for the following roles:

AERODYNAMICIST - Ensuring best use is made of CFD, Wind Tunnel and other resources available.

AERODYNAMICS SOFTWARE DEVELOPER - Providing engineering software applications generally within the Aerodynamics department.

AERODYNAMICS SURFACER - Creating parametric surface models for use throughout the Design Department to support the CFD program.

CHIEF ENGINEER - Directly responsible for all performance related aspects of the car's operation at race meetings.

COMPOSITES DESIGNER - Designing composite components and associated tooling.

GARAGE TECHNICIAN - Providing technician support to all members of the Race Team at all times.

IT SUPPORT TECHNICIAN - Supporting personnel at the factory and to the race team at all events.

MODEL DESIGNER - Designing parts for the aerodynamic wind tunnel model testing program.

NO.1 MECHANIC - Dealing with all aspects of the preparation of the car including, front end, rear suspension and engine kitting.

PERFORMANCE ENGINEER - Supporting the Race Engineer to get the best possible performance out of the car.

TECHNICAL PLANNER/BUYER - Purchasing and scheduling production/assembly of car parts.

For detailed job descriptions and to apply for these opportunities please visit the careers page of our website: www.manorf1team.com/jobs



CUSTOMER SUPPORT ENGINEER: CHASSIS

You will work under the supervision of the project manager to provide the technical interface with our Formula 4 customers. The job requires attendance at race meetings and tests around the world.

The candidate must have a good knowledge of track data acquisition systems, vehicle electronics, paddle shift systems, track simulation and performance software. Ability to use Catia V5 for occasional design office developments is also required.

The candidate should demonstrate a high degree of autonomy, working for at least 5 years in similar environment. Fluent English and French is required for this job located in Magny-Cours France. The post is available immediately for permanent contract.

*To apply, please send your CV to jobs@mygale.fr
For further information please visit www.mygale.fr*



PASSIONATE ABOUT PR?

GOOD, BECAUSE POLE LTD IS RECRUITING!

WHO WE NEED: PROFESSIONAL MOTORSPORT COPYWRITER AND THE SKILLS/EXPERIENCE REQUIRED:

- IMPECCABLE COPYWRITING
- KNOWLEDGE OF AND PASSION FOR ALL FORMS OF GLOBAL MOTORSPORT
- SOME KNOWLEDGE OF ADOBE CREATIVE SUITE SOFTWARE IS DESIRABLE
- COMFORTABLE WORKING WITH AND MANAGING A BROAD RANGE OF CLIENTS
- HARD WORKING, RELIABLE AND AN EYE FOR DETAIL

THIS IS A LONDON OFFICE-BASED ROLE REQUIRING SOME WEEKEND WORK AND OCCASIONAL LONG HOURS. THERE MIGHT ALSO BE OPPORTUNITIES TO ATTEND RACES. SALARY DEPENDANT UPON EXPERIENCE AND QUALIFICATIONS.

SEND EXAMPLES OF YOUR WORK AND CV TO CONTACT@POLE.UK.COM

MOTORSPORT JOBS

RIGHT TEAM.
RIGHT TIME.



AMG
PETRONAS
FORMULA ONE TEAM

Mercedes-Benz has been setting the standard in racing for over 100 years, and the MERCEDES AMG PETRONAS Formula One™ Team continues the proud history of the legendary Silver Arrows. We have some exciting opportunities at our Championship winning team within our Design Office and Purchasing teams.

SENIOR TEST AND DEVELOPMENT DESIGN ENGINEER SW1146

Reporting to the Head of Test & Development (T&D) Design, the successful candidate will take full ownership and responsibility for a variety of design and development tasks including car projects, T&D projects and rig & fixture design. The Senior T&D Design Engineer will see projects and designs through from concept to assembly, overseeing tests and developing improvements where possible.

STRUCTURAL ANALYSIS ENGINEER SW1198B

Reporting to the Head of Structural Analysis, the successful candidate will be involved in the design and development of a large variety of mechanical parts with an emphasis on transmission related components including gearbox case, gear change systems, gears and shafts. The Structural Analysis Engineer will need to demonstrate an in-depth understanding of transmission systems with an emphasis on gearbox internals.

SENIOR MECHANICAL DESIGN ENGINEER SW1246

Reporting to the Head of Mechanical Design, the successful candidate will take full ownership and responsibility for a variety of complex suspension projects & designs. You will deliver designs through from concept to assembly, managing planning, testing, development and troubleshooting whilst working closely with other departments to achieve the highest level of system integration.

LEAD TECHNICAL BUYER COMPOSITES CH1223

The successful candidate will be responsible for leading the Purchasing of on-car composite components and services from the external supply chain. Team focused with a strong working knowledge of ERP/MRP software (ideally SAP) and relevant logistical tools, you will be able to understand and interpret engineering drawings and composite laminate manuals. A proven competence in composite manufacturing processes and machining is required.

We are looking for team players that can think of an idea today and see it race tomorrow. You will be highly motivated and resilient and know how to work in a planful and organised way. You will be decisive yet adaptable to ensure that we achieve the highest levels of quality, reliability and performance. You will be able to communicate effectively at all levels and meet strict deadlines with minimal supervision.

In return for your hard work and commitment, we will offer a competitive package.

To find out more and join our Team:
careers.mercedesamgf1.com

Closing Date: 24 December 2015



HONDA (FORMULA 1) IS SEEKING TO FILL A NUMBER OF POSITIONS IN MILTON KEYNES BOTH IMMEDIATELY AND FOR 2016.

Honda is seeking an ERS (Energy Recovery System) Engineer to join the business on a permanent basis based in Milton Keynes to support F1 power unit development (factory and track side).

Knowledge, Skills & Experience Required:

- Strong Energy Recovery System (ERS) exposure
- Advanced user of data logging systems and analysis packages
- Advanced ERS / Battery analysis, monitor and development experience
- ERS testing methodologies
- Fault finding and diagnostic abilities
- Excellent document presentational skills

Honda is seeking an ERS (Energy Recovery System) Technician to join the business on a permanent basis based in Milton Keynes to support F1 power unit development (factory and track side).

Knowledge, Skills & Experience Required:

- Energy Recovery System (ERS) exposure
- Track side experience

- Strong skill set to manage high voltage battery system
- ERS testing methodologies
- Fault finding and diagnostic abilities
- Factory & Track side experience

It is a prerequisite that overseas travel will be required.

Honda (Formula 1) require candidates to have the following personal competencies: Engineering Enthusiasm, Analytical, Self-Motivated and Competitive, Excellent Communication Skills, High Integrity, Problem Solving and Decision Making Skills.

All applicants must have the right to work in UK on applying.

To apply please send your CV to

Nick Gerrell - nickg@gahl.co.uk

HONDA
The Power of Dreams

CLUB AUTOSPORT

NATIONAL RACING • HISTORICS • RALLYCROSS • HILLCLIMB • TRACK TESTS



Beechdean snaps up F4 duo

REIGNING BRITISH GT CHAMPION BEECHDEAN Motorsport has announced BRDC Formula 4 graduates Jordan Albert and Jack Bartholomew as its pairing to attempt to take its third consecutive British GT4 crown in 2016.

Albert and Bartholomew, sixth and seventh respectively in this year's F4 campaign, will drive an updated Aston Martin Vantage GT4 for Beechdean, which won GT3 and GT4 honours in 2015. They tested the car for the first time in October.

"I'm extremely happy to be joining the Beechdean AMR team and racing in the British GT championship in 2016," said 19-year-old Albert, who picked up two F4 victories. "They're proven championship winners and with their support I'm aiming to be competitive right from the first round.

"I have tested the Aston Martin V8 Vantage GT4 car and immediately felt comfortable. As it's my first season in a GT car it's going to be a challenging year ahead but I'm fully focused on the task.

"I am also very happy to be racing alongside Jack Bartholomew; we raced against each other this year in the BRDC F4 Championship and get on very well. I think we will make a very competitive partnership."

That sentiment was echoed by former karting

champion Bartholomew. The 17-year-old, who scored two podiums in F4, decided a switch from single-seaters was in the best interests of his career.

"It's a great team to be a part of," he said. "I get on really well with Jordan, so we should make a good pair. They're very different driving styles [F4 and GT]. F4 was great, but with the new car coming in and new teams the budgets have gone through the roof. I don't have a large backer and, to be honest, I know the F1 dream isn't going to happen, so I think I've taken a relatively mature decision to move to British GT."

Albert and Bartholomew will attempt to follow in the footsteps of 2014 champions Ross Wylie and Jake Giddings and '15 title winners Ross Gunn and Jamie Chadwick, all of whom landed the crown in their rookie seasons.

Team principal and GT3 champion Andrew Howard said: "I am extremely excited with signing both Jack and Jordan for our British GT4 campaign in 2016. It's great to see youngsters coming into sportscars and our aim is to give both drivers the platform to demonstrate their skills in British GT.

"We had a fantastic 2015 by winning the championship with a round to spare and our goal is to have more success with Jack and Jordan."

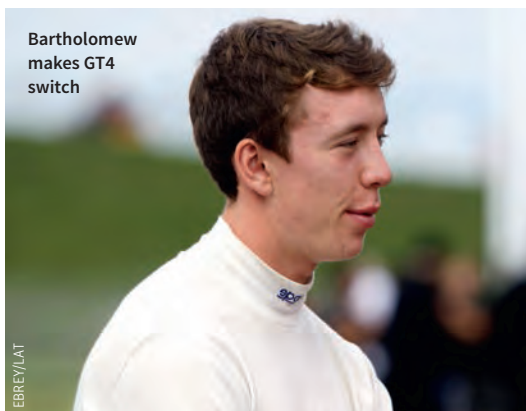

COMMENT

ROBERT LADBROOK
GROUP NATIONAL EDITOR



GT4. AS A CONCEPT, it's finally working.

It's taken a while, but SRO's constant banging of the drum for its second-tier

category is finally starting to pay off, and Beechdean's latest driver pairing is a perfect example of the reward.

GT4 has been a slow burner for years. In its infancy it was looked down upon as the poor man's British GT, the reserve of limited-run production 'Superlight' racers and dominated by Ginettas. Times really are changing.

SRO has worked hard to boost interest in the category and get manufacturers involved. It's worked. Aston Martin, Lotus, Porsche, Ginetta and Toyota have all wheeled out offerings in recent years. Having those car makers on board boosts the profile of the class no end. Manufacturers like it as GT4 cars are based on their road-going variants, so are relatively cheap to engineer compared to the more intricate GT3s.

That saving gets passed on to the drivers too, with a GT4 budget costing less than half that for a GT3 campaign. That's very timely, with GT3 costs rising dangerously every year.

That young drivers with single-seater and karting pedigrees are opting to jump into GT4 at an early stage of their careers shows the change in attitude towards the class from customers.

Many expect the GT4 grid to outnumber GT3 within the British championship in the next few years, and the early signs are enforcing that. And who can argue, when you're getting a real, branded GT car to race at top circuits in Britain's best sportscar championship, yet for less money? It sounds a winner to me.





EBREY

HSCC Super Touring to Knockhill

THE HSCC SUPER TOURING CAR CHALLENGE will make its first visit to Knockhill next season, with the prestigious David Leslie Trophy up for grabs.

Organisers of the championship, which caters for top-flight touring car machines produced up to 2000, have struck a deal to visit the Fife track for its season finale on September 10-11.

That event is traditionally held for the David Leslie Trophy Formula Ford 1600 contest, but the Scottish Motor Racing Club will present a second trophy to the Super Touring winner. The meeting will also celebrate 60 years of the SMRC.

Super Touring organiser Johnny Westbrook told *Autosport*: "This is really exciting because we've been talking to Knockhill for a few years now, but we needed to grow the championship to the point where we had the support to confidently run a round there.

"Over the last two years we've really gathered momentum. We started the season with 20 cars and had

35 at the Silverstone Classic. We're confident of getting numbers to Knockhill and the track will be epic. Just watch the 1999 race there on YouTube and it shows you how close the racing is there, as the track is tight and technical."

The deal does mean that the STCC will not support the British Touring Car Championship in 2015, after doing so for a round in each of the last two years. "It was great that we ran with the BTCC as it boosted our profile, but the chance didn't arise for 2016," added Westbrook. "Our future is with historic racing and the calendar features pretty much every major event."

Knockhill events director Stuart Gray said: "Super Touring has a great history with Knockhill. We had our largest crowd ever – in excess of 20,000 – here in the late '90s. To have them race here again will be like a return to the glory days, and it's only right we provide a second David Leslie Trophy to commemorate it.

"We want to make it like a touring car festival as it's a month after our BTCC round. The fans should love it."

MSA FORMULA

James Pull aiming for title with Carlin in 2016



EBREY/LAT

MSA FORMULA DRIVER

James Pull will switch to the championship-winning Carlin team for the 2016 season.

The 16-year-old finished 10th in the points this year, picking up four podiums, driving for both JTR and Fortec Motorsports.

Pull is now aiming for the title after a frustrating first season in the category.

"I'm really excited to be joining Carlin," he said. "They have a winning mentality

and a very strong car.

"This season was all about gaining experience. Now I know the tracks, I know the championship and I hope I can challenge for the title."

Pull has already tested with the team and impressed team boss Trevor Carlin.

"We expect to see James as a championship contender in 2016," he said. "Last year we could see a good turn of speed and lots of potential."

BRDC F4

LEIST STAYS AT DOUBLE R BUT SWITCHES TO BRDC F4

DOUBLE R RACING HAS announced Matheus Leist as the first of its three drivers when it enters BRDC Formula 4 next year.

The Brazilian raced with the team in MSA Formula this season and impressed by taking two wins on his way to fifth in the standings.

"The car is a big step on from the car I raced this year, it's very quick and has a lot of grip from the aero – I'm really impressed by it," said the 18-year-old. "Hopefully we can have some strong preparation over the winter and push for the championship. I know Double R will give me a great car."

Team principal Anthony Hieatt added: "We're absolutely thrilled Matheus is staying with us for the move into BRDC F4 and I'm confident he can be a realistic contender for the first championship.

"He has the experience of a couple of outings in Formula 3 with us last year, too, so that will be a big benefit."

Meanwhile, HHC Motorsport, which ran Will Palmer to the 2015 F4 title, has retained 17-year-old South African Sisa Ngebulana for his second season in the series. Ngebulana finished third in the recent Winter Series.



EBREY

MIGHTY MINIS

Mini series swap BRSCC for BARC

BOTH THE SUPER AND MIGHTY MINI championships will be organised by the British Automobile Racing Club from next season after ending their 20-year partnership with the BRSCC.

Series organiser Mighty Minis Racing has applied to the Motor Sports Association to make the switch for both the production-based Mighty and modified Super Mighty grids, which total around 40 cars.

Championship coordinator Rodger Tello,

who has also stepped down from his post as a director of the BRSCC as a result of the move, said: "We want to grow Mighty Minis Racing and we felt that a change of scenery was needed to do that.

"By joining the BARC we have access to different circuits, and have the option to get on to many more promoted events, such as truck racing meetings, which draw in great crowds. We're also working to reduce costs through savings on entry fees."



WALKER

MG METRO CUP

Metro Cup to run single class in 2016

THE MG METRO CUP WILL run as a single-class championship in 2016 after series organisers opted to merge the technical regulations.

From next year the series will equalise performance between the A Series and K Series-engined cars. The decision means that all the 1.4-litre Turbo, 100 and Metro cars will run under a single

set of rules, with performance modifications effectively banned.

In an attempt to reduce budgets and make the championship accessible, limited slip differentials, modified gearboxes and modified engine cylinder heads will be banned.

Metro Cup chairman James Dunkley said: "The changes have been made to simplify

the championship and to reduce the cost. We've had instances of people spending over £5000 just for engine preparation.

"The modified K Series runner will only lose about one second per lap with the changes."

Series organisers will use a balancing system of weight and ride height to equalise cars, which will be reviewed.



EBREY

FORMULA FORD

Byrne secures Irish scholarship

NORTHERN IRISH FORMULA FORD 1600 CHAMPION Jake Byrne has been chosen as the Motorsport Ireland Young Racing Driver of the Year.

The 21-year-old scored 10 wins this year driving a Ray GR13 and beat Jordan Dempsey and James Roe to win the Sexton Trophy.

Byrne's prize is a fully funded FF1600 season in the Motorsport Ireland Van Diemen that predecessor Jonny McMullan used to claim this year's National title.

"I am obviously delighted to win this amazing award," he said. "I'm already looking forward to next year and expect more wins and championships!"

IN BRIEF



CLELAND TO RESTORE HIS OPEL MONZA

Double British Touring Car champion John Cleland is planning to restore and race an Opel Monza he campaigned in the 1980s. Cleland raced the Production Saloon car before his BTCC career, contesting the RAC Tourist Trophy four times. The 1989 and 1995 BTCC champion now hopes to enter it in selected historic events. "The Monza has been in my father's garage for 25 years," he said. "I'm going to dig it out, prep it and get it back out there. She needs some love, care and money to get her running again."

TEAM TROPHY CHAMPIONSHIP STATUS

The MSVT Team Trophy series has been granted championship status and will be retitled the MSVT Trackday Championship from next year. The series will run five classes over seven rounds next season. The format will remain as a single 45-minute race with a mandatory pitstop to allow drivers to share the same car.

WILSON SWITCHES FIESTA TEAMS

Ford Fiesta Junior racer Elliot Wilson will return to the championship next year after joining the Race Car Consultants team of multiple Fiesta champion David Ellesley. "It is clear to me that he will be a championship contender," said Ellesley of the West Malling racer.

WOODER STAYS PUT IN JUNIORS

Ginetta Junior Championship racer Dave Wooder will remain with the Total Control Racing team of former BTCC racer Lee Brookes for a second season in 2016. The 16-year-old Wooder claimed a pole position on his way to 13th in the points this year.

GT RACER SIMPSON INJURES BACK

British GT driver Mike Simpson sustained back injuries during a karting crash at PF International last weekend, fracturing his L2 vertebrae. In a Facebook post, Simpson (below) said: "It was a proper call to run slicks on a damp track. The chain came off on the back straight, I pulled off line, hit the water on slicks and was then a passenger. It was a hard hit!"



EBREY/LAT

DAMON HILL TO STAR IN WILLIAMS SPECTACULAR

GET CLOSE TO THE
CARS, STARS & ACTION

14-17TH JANUARY 2016*
NEC BIRMINGHAM



WILLIAMS

 **AUTOSPORT**
INTERNATIONAL

**THE RACING
CAR SHOW**

BOOK NOW

AUTOSPORTINTERNATIONAL.COM
0844 581 1420

*14TH & 15TH TRADE DAYS ONLY

The world-famous Autosport International show is heading to Birmingham's NEC from 14-17 January, and motorsport fans have more reason than ever to be excited. See triple FIA world champion Petter Solberg drift his FIA World Rallycross machine in the Live Action Arena, get up close to some of Williams Martini Racing's most famous Formula One™ cars and listen in awe to the heroic stories of motorsport legends like Damon Hill OBE.

The centrepiece of Autosport International 2016 is a tie-up with Williams that brings all of the glamour of a Formula One race weekend to the Autosport stage. For the first time ever, the eight-metre-tall Williams Martini Racing motorhome will be constructed away from a race circuit to form part of the exciting new Autosport stage, which will be packed full of insightful interviews and features with famous faces from motorsport.

What's more, Williams will be bringing an incredible selection of its most famous Formula One cars to the NEC, from the very first Williams-Ford FW06 to this season's Williams-Mercedes FW37. Among them will be the team's greatest ever car, the Williams-Renault FW18, which won 12 of 16 races in the 1996 season. As well as interactive features focusing on Williams' F1 exploits, visitors will also get an insight into the world of Williams

Advanced Engineering, the division that transfers technology from Formula One to market sectors as diverse as defence and renewable energy.

Elsewhere at Autosport International, the 5,000-seater Live Action Arena gives showgoers the chance to experience all of the raw sights and sounds of pure racing machines. Triple FIA world champion, Petter Solberg, is just one of the highlights, drifting his 600bhp Citroen DS3 within centimetres of the track barriers. Fans will also be able to see incredible driving stunts and insightful interviews with legendary racing drivers across the weekend.

Autosport International features every form of motor racing from karting to Formula One, allowing showgoers unrivalled access to racing machines from across the world. The BTCC and Formula One grid features immerse fans in a gridwalk of current racing cars from each championship, while a new historic racing display entitled 'When We Were Kings' brings together some of the most iconic models from the golden eras of racing.

Tickets to Autosport International are on sale now, and can be purchased from www.autosportinternational.com or on **0844 581 1420**.



The Williams Martini Racing Motorhome



Damon Hill: 1996 Formula One World Champion

GREAT GIFT
IDEA FOR
F1 FANS



FREE

MERCEDES THERMO MUG

WHEN YOU SUBSCRIBE TO



SUBSCRIBE ONLINE AT

www.themagazineshop.com/taspo-dec15

QUOTE M1215P FOR PRINT OR M1215B FOR PRINT AND DIGITAL ACCESS

OR CALL US

08448 488 817

Calls cost 7 pence per minute plus your phone company's access charge.

PRINT SUBSCRIPTION ACCESS
+ FREE GIFT

UNLIMITED ACCESS FOR JUST AN EXTRA £6.25



- ✓ SPREAD THE COST PAY JUST £34.99 EVERY 13 ISSUES BY DIRECT DEBIT
- ✓ GREAT SAVING **27%** ON THE COVER PRICE
- ✓ **FREE** P&P EVERY ISSUE DELIVERY TO YOUR DOOR



- ✓ **HUGE SAVING 35%**
- ✓ ACCESS TO SUBSCRIBER-ONLY ANALYSIS AND CONTENTS

HURRY OFFER ENDS
JANUARY 8 2016

TERMS AND CONDITIONS This offer is open to UK residents only. Calls cost 7 pence per minute plus your phone company's access charge. If you require any assistance following the purchase of your subscription, then you can speak to a member of our customer service team on 01795 592 974, calls are charged at local rate. Overseas rates are available on +44 (0) 1795 592 974. Please allow 35 days for delivery of your gift and first issue. The gift will be sent under separate cover from the magazine. Should we run out of gifts, you may be offered an alternative gift – there is no cash alternative. To activate your Autosport online account visit <https://secure.autosport.com/subs/activate.php> and enter your activation code (your personal magazine subscriber number which will be included in your welcome email/letter) along with your email address to access exclusive autosport.com content, the digital page turner and interactive iPad edition content. Direct Debit rates are valid for one year after which they are subject to change – should prices change we will inform you in writing. We ask that you enter into a Direct Debit agreement with the intention that your subscription will continue for a minimum period of 12 months, even if the frequency of payment is for a shorter period, however, you will still have the right to cancel your Direct Debit in accordance with Direct Debit Guarantee. Should you wish to cancel your subscription it will be cancelled on expiry of the current term which will not be refundable, other than in exceptional circumstances. If a gift is included as part of the subscription offer we reserve the right to request the return of the gift. Details of the Direct Debit Guarantee are available on request. Savings are based on the standard UK print cover price of £3.70 and Autosport online £2.99. Offer ends January 8 2016. **HAYMARKET MEDIA GROUP LTD** uses a best-practice layered Privacy Policy to provide you with details about how we would like to use your personal information. To read the full privacy policy please visit our website www.haymarket.com/privacy or call us on 01795 592986. Please ask if you have any questions as submitting your personal information indicates your consent, for the time being, that we and our partners may contact you about products and services that will be of interest to you via post, phone, e-mail and SMS. You can opt-out at ANY time by emailing the datacontroller@haymarket.com or by calling 01795 592986.



Gould goes top of British hillclimb tree

By Marcus Pye, the voice of club racing

RUN ANNUALLY SINCE 1947, THE BRITISH HILLCLIMB Championship is one of national motorsport's greatest institutions, as much for its unique social flavour as intense competition among some of the bravest and most committed drivers in the land. Next year's title race will be the 70th, but the anniversary will be celebrated through 2017, when circuit racers will focus on Formula Ford's Golden Jubilee.

The shape of modern speed hillclimbing's 'premiership' is a far cry from its original calendar. Initially, it comprised five rounds – at Bo'ness (Linlithgow, Scotland, won by George Abecassis in a Bugatti T59), Shelsley Walsh (Worcester, first used in 1905), Bouley Bay (Jersey), Craigantlet (Belfast, Northern Ireland) and Prescott (Cheltenham) – each with a points-paying run-off for the quickest drivers at its climax. Inaugural champion Raymond Mays (ERA R4D) won three rounds, a feat he repeated to successfully defend the title in '48. Now it's contested over 34 rounds over 17 events, double-headers having arrived in 1999.

The specialism of machinery is very different to the championship's roots too, when most competing cars were equally at home on circuits. They evolved rapidly in each era, according to availability of suitable chassis, through Cooper-JAPs (500cc singles and 1000/1100cc V-twins) to old Grand Prix, Formula 5000 and F2 bolides. Nowadays, however, leading contenders use bespoke equipment, designed for the task. With massive traction, high downforce and sharp handling, these lightweights dominate the capacity classes, some smaller engines reverting to forced induction, favoured in the early days.

This season saw a massive record broken when first-time champion Alex Summers scored the 18th British championship victory for a Gould driver. It is 30 years since Gloucestershire-domiciled German architect Chris Cramer inscribed David and

Sean Gould's marque on the roll of honour with the magnificent honeycomb-chassised 84/2, powered by a 2.5-litre Hart engine. My favourite hillclimb car, it earned David Autosport's first John Bolster Trophy for technical achievement in 1985 – a tantalus of decanters containing vodka and tomato juice, the constituents of a Bloody Mary, after which JVB named his special.

Former BRM and LEC F1 designer Mike Pilbeam's eponymous creations – made in Bourne, Lincolnshire, from which the fabled ERAs sprang pre-war – had six titles to their name by then, Alistair Douglas-Osborn having bagged the first in 1977 with a Cosworth DFV-powered Brabham BT38-derived MP22. Through the efforts of Martyn Griffiths, James Thomson, Martin Bolsover, Charles Wardle, Roy Lane, David Grace, Andy Priaulx, and Roger Moran in '97, that figure snowballed to 17.

Since 1998, a Gould has prevailed every season bar 2012, when Trevor Willis stemmed a 14-year winning streak with one of Yorkshireman Steve Owen's OMS designs, propelled by a Radical Powertec V8 engine, a version of which has powered Argentina's TC2000 silhouette touring car championship since 2011. Grace, Graeme Wight Jr, Adam Fleetwood, Martin Groves and Scott Moran (Roger's son, champion five times in seven years, and contributor of 134 of Gould's 437 round wins) have won crowns in the Newbury-built chassis.

I'm proud to have known David Gould since the 1970s, when he was an electrical engineer competing in Terrapins built by the late Allan Staniforth. Having changed career, it has been fascinating to watch David and son Sean – capable drivers both, with three RAC round victories between them – turn their hobby into a business, established in a tiny workshop behind the family home, into the world leader in its field. Having drawn inspiration from F1, when Patrick Head of Williams happily offered advice, Gould Engineering has now long supplied it. ✘



MAKI SET FOR HISTORIC F1 RETURN

The Japanese Maki F101C Formula 1 car in which Tony Trimmer contested the 1975 Swiss GP is being rebuilt to race in 2016, having been acquired by Belgian enthusiast Mark Devis.

Engine failure stopped it racing in the '75 Dutch GP, and it has lain dormant since Joop Rauwers drove it in FIA Thoroughbred GP races.



HUNT AND BRABHAM HONOURED

Goodwood will pay tribute to F1 champions James Hunt and Sir Jack Brabham respectively at its 24th Festival of Speed (June 24-26) and 19th Revival Meeting (September 9-11).

The 100th Indianapolis 500 and the 50th anniversary of the first Can-Am Challenge Cup series will be celebrated in the hillclimb event.



SEBRING 12 HOURS RETRO PLANS

Leading US promoter Historic Sportscar Racing (HSR) has launched the Classic 12 Hours of Sebring, Pistons & Props retrospective – to be held on December 1-4 in 2016.

The debut event will feature races for cars spanning the history of the original Floridian enduro, run since 1952, and historic aircraft.

WHAT'S ON

The battle of the F1 broadcasters

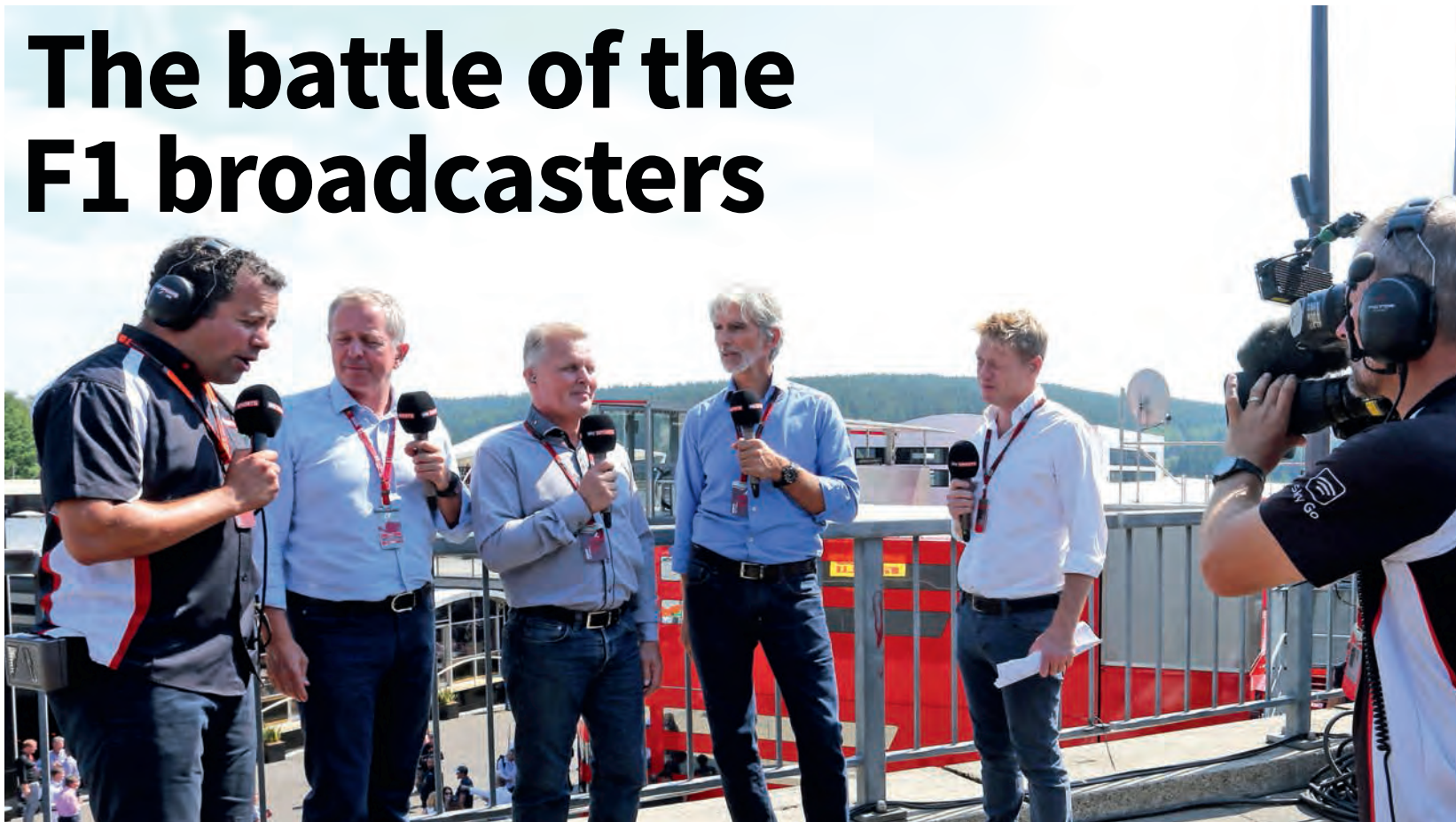

IT'S BEEN A CHALLENGING YEAR for Formula 1 broadcasters in the UK, forced to make the most of a dull season on track, and handle a tragedy and political machinations off it.

Both the BBC and Sky Sports F1 excelled themselves with fitting tributes to Jules Bianchi, the Beeb's classy feature hitting a particularly fine note in championing his achievements and underlining what we'll miss.

It was a strong year for the BBC features department. The emotionally resonant rallycross film starring Jenson Button, David Coulthard and a 600bhp VW Beetle the pick of the bunch. In contrast, too many of Sky's efforts went down the 'presenter-messes-around-with-driver-doing-something-eccentric' route. As much as you might enjoy seeing Simon Lazenby getting cracked in the nuts by a stray baseball bat, there was sometimes too much banter.

Sky's overall style took a partisan turn, with Lewis Hamilton creeping into nearly every aspect of the show.

The channel had a choppy year on the commentary front, David Croft too often drifting into rants. Tied to that awkward palliness with Martin Brundle, Sky's commentary sometimes struggled to match the dependable Ben Edwards and David Coulthard on the BBC. Its support team also looked hollow, with Bruno Senna and Anthony Davidson, the strongest of the ex-driver line-up, absent for part of the season.

Although Suzi Perry still looks like she would rather be elsewhere at times, and

BBC coverage often ended too quickly



Eddie Jordan's unique style is divisive, the BBC can still boast Allan McNish and Tom Clarkson in support of its front three. They are two of its strongest assets, but the BBC's limited run time meant they were not used enough.

This is where the BBC suffers, with broadcasts often wrapped up within 15 minutes of the chequered flag. Take Monza, when the world awaited the verdict of the Mercedes tyre investigation. Sky, with an entire channel at its disposal, stuck it out, and was on air to break the news that the result would stand. It's a perfect example of what the channel should be.

Innovations such as *F1 Legends* and *Tales from the Vault* have become overfamiliar in their function as bookends around sessions. Surely no one needs to hear again how Eddie Irvine took a punch from Ayrton Senna, or how apparently Michael Schumacher couldn't set up a car?

Given recent developments, Sky could be the only place to watch F1 in

GET
AUTOSPORT
ON THE
MOVE

DOWNLOAD IT
NOW FROM
AUTOSPORT.COM



Sky team did not always hit the mark

WPBIMAGES

the UK next season, with the BBC's free-to-air coverage under threat. Spending cuts are required and F1 is no longer the mass-market sell it once was, particularly with coverage in its current maimed state, so motorsport could be in the firing line.

Even though this hasn't been Sky's strongest year, its competition with the BBC has driven the quality of F1 coverage forward across both stations. To lose F1 from free-to-air TV will have major repercussions not just for audiences, but the sort of exposure that creates, in Coulthard's words, "the next generations of engineers and mechanics". Furthermore, Brundle's impassioned plea for BBC F1's survival at the Autosport Awards showed that even the pay-TV side is aware of free-to-air's value.

Perry closed out the final broadcast of 2015 with an uncertain message: "We will see you next year, hopefully." She's not the only one hoping.

DAN PADDOCK



HOT ON THE WEB THIS WEEK

YouTube McLAREN'S FUTURE-TECH CONCEPT

Search for: McLaren MP4-X Concept Car

McLaren reveals its take on the racing car of the future. All the technology employed here is real, according to the car's creators, even if it's still in its earliest stages of conception. All very exciting, although the *Tron*-like video fails to reveal how well the MP4-X goes around corners... More info is available at <http://mclrn.co/MP4-X>



AUTOSPORT AWARDS 2015

Motors TV

Sunday 0925

One of the most prestigious nights in motorsport, the Autosport Awards brings together some of the biggest names of the sport. Hour-long highlights are all weekend on Sky Sports F1, or catch Sunday's extended play on Motors TV from 0925.

TV PICK
OF THE
WEEK

SBLOXHAM/LAT

INTERNATIONAL MOTORSPORT

SEPANG 12 HOURS

December 12

Sepang, Malaysia

This weekend's Sepang 12 hours will be its last as a standalone event; next year it will form part of the Intercontinental GT challenge. Last year's winner Clearwater Racing returns to defend its title, but will face stiff competition, with some of the finest GT teams and drivers in the world eager to snatch its crown.

WATCH ON TV
Live: Motors TV
Saturday 0345

V8 STOCK CAR

Rd 12/12

December 13

Interlagos, Brazil

It's always a sign that Christmas is drawing in when the Brazilian V8 Stock Car season comes to a close. Defending champion and F1 legend Rubens Barrichello may have been dethroned by Marcos Gomes, but the hometown hero will be out to impress in Sao Paulo in front of his adoring fans.

ANDROS TROPHY

Rd 2/7

December 11-12

Andorra

There's an excursion for the field this week, with the second round taking place over the French border on the tight and twisty Circuit d'Andorra. Five-time winner Jean-Philippe Dayraut goes up against ex-Toyota and Prost F1 driver Olivier Panis once again for top honours in the seven-round series.

WATCH ON TV
Delayed: Motors TV
Sunday 1200, 2205

GULF 12 HOURS

December 11

Yas Marina, UAE

This is the second of this weekend's GT pickings, and represents the fifth running of the popular Gulf 12 Hours. A stellar field of 22 entries, including leading British squad Motorbase and three AF Corse Ferraris (the team is defending its 2014 title) will tackle the Yas Marina circuit in an attempt to end the season on a high.

WATCH ONLINE
gulf12hours.com

THE ARCHIVE

Atmosphere at Paul Ricard's 1973 French GP. In foreground, Shadow's Jackie Oliver (on wheel) and George Follmer chat. Hill, Fittipaldi and Merzario also in evidence. LAT Photographic





PAUL RICARD

RICARD

BRASIL

GOODYEAR GOODYEAR
STP

STP STP STP STP
GOODYEAR

elf

5

elf

STEWART
elf

kie Oliver

LEO FREE

17

ESSE

RACING

ESSE

TOP FIVE

DRACO RACING ALUMNI

After two and a half decades of launching new talent into the world of European single-seaters, the Italian-based team founded by Adriano and Nadia Morini closed its doors a few weeks ago. The team was responsible for helping numerous of big names on their way up through the ranks. Here's our top five Draco alumni, from which luminaries such as Augusto Farfus, Ricardo Zonta and Markus Winkelhock and the late Marco Campos just missed out...



1 RUBENS BARRICHELLO

In 1990, a fresh-faced 17-year-old Brazilian known as 'Rubinho' arrived in Italy to undertake his first season in Europe, in the ultra-competitive grand prix-supporting Opel Lotus Euroseries. Straight away the husband-and-wife Morini team took him under their wing as a surrogate child – setting the template under which they would look after countless subsequent Brazilians – and Barrichello flourished. He claimed the title among a field that included the highly rated Vincenzo Sospiri as well as fellow rookies David Coulthard and Gil de Ferran. Barrichello had arrived.



2 FELIPE MASSA

Massa was a 19-year-old who had swept to victory in the 2000 European and Italian Formula Renault 2.0 championships when he arrived at the Morinis' door to join their 2001 Euro 3000 team. The series wasn't recognised as the strongest but you can only beat the opposition you've got and Massa did that resoundingly. Six poles and six wins from the eight rounds elevated him straight to F1 with Sauber.

3 PEDRO LAMY

Moving away from Brazilians here but still with Portuguese-speakers... Who could follow Barrichello to lead Draco's 1991 Opel Lotus Euroseries team? Step forward Lamy, who'd had an up-and-down rookie season in the category. Straight away he was on it with Draco, and prevailed in an intra-Portuguese title battle with the underrated Diogo Castro Santos before heading to F3, F3000, then F1.



4 PASTOR MALDONADO

The hard-charging Venezuelan was controversial even in his junior days. He'd graduated to Formula Renault 3.5 in 2005 as reigning Italian FR2.0 champion only to hit the headlines for mowing down a marshal under yellow flags in Monaco. His rehabilitation began with Draco in 2006, and he dominated in Monaco before winning at Spa and Le Mans Bugatti on his way to third in the FR3.5 standings.

5 BRUNO JUNQUEIRA

Draco was competing in the F3000 International Championship when Junqueira arrived for 1998 as the reigning South American Formula 3 champion with the target of following in the wheeltracks of Ricardo Zonta, who'd started his European activities with Draco. It was a difficult season, Junqueira finishing 17th, but he would win the 2000 crown with Petrolbras Junior and become an indycar star.



AUTOSPORT

Haymarket Consumer Media, Bridge House, 69 London Road, Twickenham TW1 3SP Tel +44 (0) 20 8267 5998 Fax +44 (0) 20 8267 5922
E-mail autosport@haymarket.com Website www.autosport.com
Individual e-mail firstname.surname@haymarket.com

Editorial

Editor **Edd Straw**
Deputy Editor **Marcus Simmons**
Chief F1 Correspondent **Ian Parkes**
Grand Prix Editor **Ben Anderson**
F1 Reporter **Lawrence Barretto**
Features Editor **Scott Mitchell**
Managing Editor **Peter Hodges**
Executive Editor **Stuart Codling**
Group National Editor **Rob Ladbrooke**
Rallies Editor **David Evans**
Art Editor **Lynsey Elliott**
Senior Designer **Michael Cavalli**
Group Picture Editor **Peter Mills**
Office Manager **Joanne Grove**

Autosport.com

Editor **Glenn Freeman**
Deputy Editor **Matt Beer**
International Editor **Mitchell Adam**
Technical Team Leader **Geoff Creighton**
Senior Digital Designer **Amar Vijay**
Senior Developer **Stephen Palmer**

Special Contributors

Gary Anderson, Alan Eldridge, Mark Glendenning, Marcus Pye, Dieter Rencken, Gary Watkins

Correspondents

Argentina Tony Watson **Australia** Phil Branagan
Austria Gerhard Kuntschik **Belgium** Gordon McKay
Brazil Lito Cavalcanti **Finland** Esa Illoinen **Germany** Rene de Boer
Greece Dimitris Papadopoulos **Italy** Roberto Chinchero
Japan Jiro Takahashi **New Zealand** Bernard Carpinter
Russia Gregory Golyshev **Spain** Raimon Duran **Sweden** Tege Tornvall
USA Bruce Martin, Jeremy Shaw **UK & Ireland** Pete Allen, Jonathan Crawford, Jack Cozens, Kerry Dunlop, Tom Errington, Linda Keen, Alex Kalinauckas, Lewis Larkam, Mark Libbeter, Stephen Lickorish, Marc Orme, Dan Paddock, Graham Read, Hal Ridge, Aaron Rook, Peter Scherer, Seb Scott, Ian Sowman, Oliver Timson, Ian Titchmarsh, Eddie Walder, Richard Young

Advertising

Tel +44 (0) 20 8267 5271
E-mail autosport.ads@haymarket.com

Sales Manager

Jonathan Whitehead
Display Advertising **Don Rupal**, **Karen Reilly**
Classified Advertising **Jamie Brooker**, **Jonathan King**, **Joe Andrews**
Autosport.com Sales Manager **Fiona Bain**
Autosport.com Agency Account Manager **Jessica McFadyen**
Online Advertising **Leah Mimms**
Special Project Sales **James Robinson**
Advertising Director **Matthew Witham**

Advertising Production

Tel +44 (0) 20 8267 5588 Fax +44 (0) 20 8267 5320
Group Production Manager **Ailsa Donovan**
Production Controller **Abbey Gunner** abbey.gunner@haymarket.com

Subscriptions

UK 0844 8488817 Overseas +44 (0)1795 592 974
Email autosport@servicehelpline.co.uk
Back issues Tel 0844 8488817
Direct Marketing Executive **Kadie Chanter** +44 (0)20 8267 5622

Autosport, ISSN number 0269946X, is published weekly by Haymarket Media Group, Bridge House, 69 London Road, Twickenham TW1 3SP, United Kingdom. Airfreight and mailing in the USA by agent named Air Business Ltd, c/o Worldnet Shipping Inc., 156-15, 146th Avenue, 2nd Floor, Jamaica, NY 11434, USA. Periodicals postage paid at Jamaica NY 11431. Subscription records are maintained at Haymarket Media Group, Bridge House, 69 London Road, Twickenham TW1 3SP. Air Business Ltd is acting as our mailing agent.

Licensing and Syndication

International Director **Alastair Lewis** +44 (0)20 8267 8606
Syndication enquiries **Isla Friend** +44 (0)20 8267 5024

Management

Group Director **Tim Bulley**
Group Publisher **Stuart Williams**
Group Editor **Anthony Rowlinson**
Group Commercial Director **Ben Guynan**
Special Events Manager **Laura Coppin**
Digital Special Project Manager **Simon Strang**
Digital Product Manager **Simon Grayson**

© 2015, HAYMARKET MEDIA GROUP LTD
Publishing, trade and further subscription details on www.autosport.com. While due care is taken to ensure the contents of *Autosport* are accurate, the publishers and printers cannot accept liability for errors and omissions. Advertisements are accepted for publication in *Autosport* only upon Haymarket Media Group Ltd's Standard Terms of Acceptance of Advertising, copies of which are available from the Advertising Sales Department of *Autosport*.

CIRCULATION TRADE ENQUIRIES
Frontline Ltd, Park House, 117 Park Road, Peterborough, Cambs, PE21 2TS.
Tel: +44 (0) 1733 955161. Printed in England by Wyndeham Peterborough Ltd.
ISSN 0269-946X. *Autosport*, incorporating *Autoclassic*, is published weekly by Haymarket Consumer Media, Bridge House, 69 London Road, Twickenham TW1 3SP.

Editorial Director **Mark Payton**
Strategy and Planning Director **Bob McDowell**
Publishing Director **Patrick Fuller**
Managing Director **David Prasher**
Chief Executive **Kevin Costello**



Good design sometimes needs a little help...

...that's why global race teams use Sandwell as a prime supplier of performance engineering solutions.

- Controlled Shot Peening
- Superfinishing
- Low Friction Coatings
- Kephos Lightweight Coating
- Conductive Coatings
- Non Conductive Coatings

Sandwell works with design and development engineers throughout the world of manufacturing to improve component performance.

- Improve component fatigue life
- Increase component strength
- Improve reliability
- Reduce component weight
- Reduce surface friction
- Apply corrosion resistant coatings





RENAULT
Passion for life

Renault CLIO RENAULTSPORT

The road provides its destiny,
the track its DNA.



Clio Renaultsport 220 Trophy

After 115 years in motorsport, our name is synonymous with some of the fastest cars on the track. The same dedication and expertise is now available at our network of expertly trained Renaultsport specialist dealers countrywide.

Visit renaultsport.co.uk to find out more.

The official fuel consumption figures in mpg (l/100km) for the Renault Clio Renaultsport 220 Trophy are: Urban 37.2 (7.6); Extra Urban 55.4 (5.1); Combined 47.9 (5.9). The official CO₂ emissions are 135g/km. EU Directive and Regulation 692/2008 test environment figures. Fuel consumption and CO₂ may vary with driving styles, road conditions and other factors.