

1

Basic Mathematics & Measurements

Section I

Single Correct Option

1, $K = \frac{1}{2}mv^2$

$$\therefore \left(\frac{\Delta K}{K}\right)_{\max} = \frac{\Delta m}{m} + 2\frac{\Delta v}{v}$$

\therefore Maximum error = 2% + 2(3%)

In the estimate of,

kinetic energy (K) = 8%

Option (c) is correct.

2. $d = \frac{m}{V} = \frac{m}{l^3}$

$$\begin{aligned} \therefore \left(\frac{\Delta d}{d} \times 100\right)_{\max} &= \left(\frac{\Delta m}{m} \times 100\right) + 3\left(\frac{\Delta l}{l} \times 100\right) \\ &= 4\% + 3(3\%) \\ &= 13\% \end{aligned}$$

Option (d) is correct.

3. $p = \frac{F}{A} = \frac{F}{L^2}$

$$\begin{aligned} \therefore \text{Permissible error in pressure (p)} \\ &= 4\% + 2(2\%) \\ &= 8\% \end{aligned}$$

Option (a) is correct.

4. $p_1 V_1 = p_2 V_2$

$$\begin{aligned} \Rightarrow p_2 &= p_1 \frac{V_1}{V_2} \\ &= p_1 \frac{V_1}{V_1 - 10\% \text{ of } V_1} \\ &= \frac{p_1}{90\%} \end{aligned}$$

$$p_2 = \frac{p_1}{9}$$

$$\begin{aligned} \therefore \text{Percentage increase in pressure} &= \frac{100}{9} \\ &= 11.1 \end{aligned}$$

Option (a) is correct.

5. $K = \frac{p^2}{2m}$

$$\begin{aligned} \therefore \text{Error in the measurement of kinetic} \\ \text{energy (K)} \\ &= 2 \times 100\% \\ &= 200\% \end{aligned}$$

Option (d) is correct.

6. $3400 = 3.400 \times 10^3$

\therefore Number of significant figures = 2

Option (d) is correct.

7. $A = 3.124 \text{ m} \times 3.002 \text{ m}$

$$\begin{aligned} &= 9.378 / 248 \text{ m}^2 \\ &= 9.378 \text{ m}^2 \end{aligned}$$

Option (a) is correct.

8. $g = \frac{GM}{R^2}$
 $= \frac{\text{constant}}{R^2}$

$$\begin{aligned} K &= \frac{1}{2}I\omega^2 \\ &= \frac{1}{2}\left(\frac{2}{5}MR^2\right)\omega \\ &= \text{constant} \times R^2 \end{aligned}$$

∴ Decrease in R (radius) by 2% would increase g by 4% and decrease K (rotational kinetic energy) by 4%.

Option (b) is correct.

9. Heat (H) = $2^2 Rt$

∴ Maximum error in measuring heat (H)
 = 2(2%) + 1% + 1%
 = 6%

Option (b) is correct.

10. $V = bt$

$$\begin{aligned} &= 12 \times 6 \times 2.45 \\ &= 176.4 \\ &= 1.764 \times 10^2 \text{ cm}^3 \\ &= 2 \times 10^2 \text{ cm}^2 \end{aligned}$$

Option (b) is correct.

11. $I = \frac{P}{4\pi r^2}$

i.e., $Ir^2 = \text{constant}$

i.e., if r is increased by 2% the intensity will decrease by 4%.

Option (d) is correct.

12. Option (b) is correct.

13. $V = \frac{4}{3} \pi r^3$

$$\begin{aligned} \frac{\Delta V}{V} &= 3 \frac{\Delta r}{r} \\ &= 3(1\%) \\ &= 3\% \end{aligned}$$

Option (c) is correct.

14. $a^3 = 6a^2$ (given)

$$\begin{aligned} \therefore a &= 6 \\ \Rightarrow V &= 6^3 = 216 \text{ m}^3 \end{aligned}$$

Option (b) is correct.

15. $g = 4\pi^2 \frac{l}{T^2}$

$$\begin{aligned} \therefore \left(\frac{\Delta g}{g} \times 100 \right)_{\text{max}} &= \frac{\Delta l}{l} \times 100 + 2 \left(\frac{\Delta T}{T} \times 100 \right) \\ &= \left(\frac{1 \text{ mm}}{100 \text{ m}} \times 100 \right) + 2 \left(\frac{0.15}{2003} \times 10 \right) \\ &= 0.1\% + 0.1\% = 0.2\% \end{aligned}$$

Option (a) is correct.

16. $Q = I \alpha e^{-\frac{tI}{(\Delta V)\epsilon_0\beta}}$ (given)

We know that

$$Q = It$$

$$\therefore t = \alpha e^{-\frac{tI}{(\Delta V)\epsilon_0\beta}}$$

$$\Rightarrow [\alpha] = [t]$$

$$\text{and } [\beta] = \left[\frac{tI}{(\Delta V)\epsilon_0} \right]$$

$$\begin{aligned} \Rightarrow \left[\frac{\beta}{\alpha} \right] &= \left[\frac{tI}{(\Delta V)\epsilon_0 t} \right] = \left[\frac{I}{(\Delta V)} \right] \left[\frac{1}{\epsilon_0} \right] \\ &= \frac{1}{[\text{Resistance}]} \left[\frac{1}{\epsilon_0} \right] \end{aligned}$$

$$\begin{aligned} \text{or } \left[\frac{\beta}{\alpha} \right] &= \frac{1}{[\text{ML}^2\text{T}^{-3}\text{A}^{-2}]} \frac{1}{[\text{M}^{-1}\text{L}^{-3}\text{T}^4\text{A}^2]} \\ &= \frac{1}{[\text{L}^{-1}\text{T}]} = [\text{velocity}] \\ &= \frac{1}{[\mu_0\epsilon_0]^{1/2}} \end{aligned}$$

Option (a) is correct.

17. $a = \frac{\sqrt{pq}}{r^2 s^3}$

$$\begin{aligned} \left(\frac{\Delta a}{a} \times 100 \right)_{\text{max}} &= \frac{1}{2} \left(\frac{\Delta p}{p} \times 100 \right) + \frac{1}{2} \left(\frac{\Delta q}{q} \times 100 \right) \\ &\quad + 2 \left(\frac{\Delta r}{r} \times 100 \right) + 3 \left(\frac{\Delta s}{s} \times 100 \right) \\ &= \frac{1}{2} (1\%) + \frac{1}{2} (3\%) + 2(0.5\%) + 3(0.33\%) \\ &= 0.5\% + 1.5\% + 1\% + 1\% \\ &= 4\% \end{aligned}$$

Option (c) is correct.

18. Least count of main scale

$$= \frac{2 \text{ mm}}{4} = 0.5 \text{ mm}$$

$$\begin{aligned} \text{Least count} &= \frac{\text{least count of main scale}}{50} \\ &= 0.1 \text{ mm} \end{aligned}$$

$$\text{Zero error} = -30 \times 0.01 \text{ mm}$$

$$= -0.3 \text{ mm}$$

(-ive sign, zero of circular scale is lying above observed reading of plate thick)

$$= 2 \text{ MSR} + 20 \text{ CSR}$$

4 | Mechanics-1

$$\begin{aligned}
 &= (2 \times 0.5 \text{ mm}) + (20 \times 0.01 \text{ mm}) \\
 &= 1 \text{ mm} + 0.2 \text{ mm} \\
 &= 1.2 \text{ mm.}
 \end{aligned}$$

Plate thickness (corrected reading)

$$\begin{aligned}
 &= \text{observed reading} - \text{zero error} \\
 &= 1.2 \text{ mm} + 0.3 \text{ mm} \\
 &= 1.5 \text{ mm}
 \end{aligned}$$

Option (d) is correct.

More than One Correct Options

1. Maximum percentage error in x :

$$\begin{aligned}
 &= (\% \text{ error in } a) + 2(\% \text{ error in } b) + 3(\% \text{ error in } c) \\
 &= 15\%
 \end{aligned}$$

Assertion and Reason

1. Least count of screw gauge

$$= \frac{\text{Pitch}}{\text{Number of divisions of circular scale}}$$

Less the value of pitch, less will be least count of screw gauge leading to less uncertainty that is more accuracy in the measurement.

Thus, assertion is true.

From the above relation we conclude that least count of screw gauge is inversely proportional to the number of divisions of circular scale.

Thus reason is false.

Option (c) is correct.

Match the Columns

1. (a) $F = \frac{GM_1M_2}{r^2}$

$$\begin{aligned}
 \therefore GM_1M_2 &= Fr^2 \\
 \text{i.e., } [GM_1M_2] &= [MLT^{-2}][L^2] \\
 &= [ML^3T^{-2}]
 \end{aligned}$$

\therefore (a) \rightarrow (q)

(b) $\frac{3RT}{M} = \frac{3pV}{n} = \frac{3 \text{ work}}{nM}$

$$\therefore \left[\frac{3RT}{M} \right] = \left[\frac{ML^2T^{-2}}{M} \right] = [L^2T^{-2}]$$

\therefore (b) \rightarrow (r)

(c) $\frac{F^2}{q^2B^2} = \left(\frac{F}{qB} \right)^2$

$$= \left(\frac{qvB \sin \theta}{qB} \right)^2$$

$$= v^2 \sin^2 \theta$$

$$\therefore \left[\frac{F^2}{q^2B^2} \right] = [LT^{-1}]^2 = [L^2T^{-2}]$$

\therefore (c) \rightarrow (r)

(d) $g = \frac{GM_e}{R_e^2}$

$$\frac{GM_e}{R_e} = gR_e$$

$$\Rightarrow \left[\frac{GM_e}{R_e} \right] = [LT^{-2}][L]$$

$$= [L^2T^{-2}]$$

\therefore (d) \rightarrow (r)

2

Units & Dimensions Vectors

Section I

Single Correct Option

1. Pressure (p) = $\frac{\text{Force}}{\text{Area}}$
 $\therefore [p] = \frac{[\text{MLT}^{-2}]}{[\text{L}^2]}$
 $= [\text{ML}^{-1}\text{T}^{-2}]$

Option (d) is correct.

2. $W = I^2 R t$
 $\therefore [R] = \frac{[\text{ML}^2\text{T}^{-2}]}{[\text{A}^2\text{T}]} = \frac{[\text{ML}^2\text{T}^{-2}\text{A}^{-2}]}{[\text{T}]} \dots(i)$

$V = L \frac{dI}{dt}$ and $W = Vq$

$\therefore L = \frac{W}{q} \frac{dt}{dI}$
 $[L] = \frac{[\text{ML}^2\text{T}^{-2}][\text{T}]}{[\text{A}^2\text{T}]} = [\text{ML}^2\text{T}^{-2}\text{A}^{-2}]$

Using Eq. (i)

$$[R] = \frac{[L]}{[T]}$$

i.e., $[T] = \frac{[L]}{[R]}$

Option (c) is correct.

3. $F = 6\pi \eta av$
 $\therefore [\eta] = \frac{[F]}{[av]}$
 $= \frac{[\text{MLT}^{-2}]}{[\text{LLT}^{-1}]}$
 $= [\text{ML}^{-1}\text{T}^{-1}]$

Option (d) is correct.

4. $\phi = Li$
 $\therefore [\phi] = [L][i]$
 $= [\text{ML}^2\text{T}^{-2}\text{A}^{-2}][\text{A}]$
 $= [\text{ML}^2\text{T}^{-2}\text{A}^{-1}]$

Option (a) is correct.

5. Linear impulse (I) = $F \cdot \Delta t$
 $[I] = [\text{MLT}^{-2}][\text{T}]$
 $= [\text{MLT}^{-1}]$

Option (c) is correct.

6. $F = G \frac{m_1 m_2}{d^2}$
 $[G] = \frac{[F][d^2]}{[m_1 m_2]} = \frac{[\text{MLT}^{-2}][\text{L}^2]}{[\text{M}^2]}$
 $= [\text{M}^{-1}\text{L}^3\text{T}^{-2}]$

Option (c) is correct.

7. $F = \frac{\mu_0 i_1 \cdot i_2}{4\pi d}$
 $\therefore [\mu_0] = \frac{[\text{MLT}^{-2}][\text{L}]}{[\text{A}^2]} = [\text{ML}^2\text{T}^{-2}\text{A}^{-2}]$

Option (c) is correct.

8. $[k] = \frac{[L]}{[\text{LT}^{-1}]} = [\text{T}]$

Option (c) is correct.

9. $[a] = \frac{[\text{MLT}^{-2}]}{[\text{T}]} = [\text{MLT}^{-3}]$
 $[b] = \frac{[\text{MLT}^{-2}]}{[\text{T}^2]} = [\text{MLT}^{-4}]$

Option (c) is correct.

6 | Mechanics-1

10. $E = h\nu$

$$\therefore [h] = \frac{[\text{ML}^2 \text{T}^{-2}]}{[\text{T}^{-1}]} = [\text{ML}^2 \text{T}^{-1}]$$

$$\text{Angular momentum } (J) = \frac{nh}{2\pi}$$

$$[J] = [h] = [\text{ML}^2 \text{T}^{-1}]$$

Option (b) is correct.

11. $[\text{Energy}] = [\text{ML}^2 \text{T}^{-2}]$
 $= [\text{M}][\text{L} \text{T}^{-1}]^2$

$$\therefore [\text{Mass}] = [E\nu^{-2}]$$

Option (c) is correct.

12. $\frac{1}{2} \varepsilon_0 E^2 = \text{Energy density} = \frac{\text{Energy}}{\text{Volume}}$

$$\therefore \left[\frac{1}{2} \varepsilon_0 E^2 \right] = \frac{[\text{ML}^2 \text{T}^{-2}]}{[\text{L}^3]}$$

$$= [\text{ML}^{-1} \text{T}^{-2}]$$

Option (b) is correct.

13. $[a] = [\text{T}^2]$

$$[b] = \frac{[\text{T}^2]}{[\text{L}][\text{ML}^{-1} \text{T}^{-2}]}$$

$$\therefore \left[\frac{a}{b} \right] = [\text{MT}^{-2}]$$

Option (b) is correct.

14. Velocity gradient $= \frac{dv}{dx}$

$$[\text{Velocity gradient}] = \frac{[\text{L} \text{T}^{-1}]}{[\text{L}]}$$

$$= [\text{T}^{-1}]$$

$$= [\text{M}^0 \text{L}^0 \text{T}^{-1}]$$

Option (a) is correct.

15. $[\text{Force}] = [\text{ML} \text{T}^{-2}]$

$$\therefore [\text{Mass}] = \frac{[\text{F}]}{[\text{L} \text{T}^{-2}]}$$

$$= [\text{FL}^{-1} \text{T}^2]$$

Option (a) is correct.

16. Coefficient of friction (μ)

$$= \frac{\text{Limiting frictional force}}{\text{Normal force}}$$

$$\therefore [\mu] = [\text{M}^0 \text{L}^0 \text{T}^0]$$

Option (b) is correct.

17. $q = CV$

and $V = iR$

$$\therefore q = iCR$$

$$it = iCR$$

$$\Rightarrow [CR] = [t] = [\text{M}^0 \text{L}^0 \text{T} \text{A}^0]$$

Option (a) is correct.

18. $F = \frac{1}{4\pi\varepsilon_0} \frac{q_1 q_2}{r^2}$

$$\therefore \text{Unit of } \varepsilon_0 = \text{Newton-metre}^2/\text{coulomb}^2.$$

Option (b) is correct.

19. Angular momentum (J) $= \frac{nh}{2\pi}$

$$I = \Sigma mr^2$$

$$\therefore \frac{h}{I} = \frac{2\pi J / n}{\Sigma mr^2} = \frac{mvr}{\Sigma mr^2}$$

$$\left[\frac{h}{I} \right] = \left[\frac{[\text{L} \text{T}^{-1}]}{\text{L}} \right] = [\text{T}^{-1}]$$

$$= \text{Frequency}$$

Option (a) is correct.

20. $v = at + \frac{b}{t+c}$

$$[c] = [T]$$

$$\left[\frac{b}{t+c} \right] = [v]$$

or $[b] = [\text{L} \text{T}^{-1}][\text{T}] = [\text{L}]$

$$[at] = [v] = [\text{L} \text{T}^{-1}]$$

$$\Rightarrow [a] = [\text{L} \text{T}^{-2}]$$

Option (a) is correct.

21. $y = A \sin \left[\frac{2\pi}{\lambda} (ct - x) \right]$

$$= A \sin \left[\frac{2\pi}{\lambda} ct - \frac{2\pi x}{\lambda} \right]$$

$$\frac{2\pi x}{\lambda} = \theta \text{ (angle)}$$

$$\therefore [x] = [\lambda] = [\text{L}]$$

Further, $y = A \sin \theta$

$$\therefore [A] = [y] = [\text{L}]$$

Option (a) is correct.

22. $[X] = [\text{M}^{-1} \text{L}^{-3} \text{T}^3 \text{A}^2]$

$$= \frac{[\text{T} \text{A}^2]}{[\text{ML}^2 \text{T}^{-2}]}$$

$$= \frac{[t][l^2]}{[\text{Work}]}$$

∴ X is resistance.

$$[\because W = i^2 R t]$$

23. $\vec{F} = 2\hat{i} - 3\hat{j} + 4\hat{k}$

$$\vec{r} = 3\hat{i} + 2\hat{j} + 3\hat{k}$$

$$\therefore \vec{\tau} = \vec{r} \times \vec{F} = \begin{vmatrix} \hat{i} & \hat{j} & \hat{k} \\ 3 & 2 & 3 \\ 2 & -3 & 4 \end{vmatrix}$$

$$\text{or } \vec{\tau} = 17\hat{i} - 6\hat{j} - 13\hat{k}$$

24. $\sqrt{(0.5)^2 + (0.8)^2 + (c)^2} = 1$

$$\text{or } 0.25 + 0.64 + c^2 = 1$$

$$\text{or } c^2 = 1 - 0.89$$

$$c = \sqrt{0.11}$$

Option (b) is correct.

25. $|\vec{A} + \vec{B}| = |\vec{A} - \vec{B}|$

$$(\vec{A} + \vec{B}) \cdot (\vec{A} + \vec{B}) = (\vec{A} - \vec{B}) \cdot (\vec{A} - \vec{B})$$

$$A^2 + B^2 + 2\vec{A} \cdot \vec{B} = A^2 + B^2 - 2\vec{A} \cdot \vec{B}$$

$$\text{i.e., } \vec{A} \cdot \vec{B} = 0$$

∴ Angle between \vec{A} and $\vec{B} = 90^\circ$

26. $(\vec{A} + \vec{B}) \cdot (\vec{A} - \vec{B}) = 0$

$$\vec{A} \cdot \vec{A} + \vec{B} \cdot \vec{A} - \vec{B} \cdot \vec{B} - \vec{A} \cdot \vec{B} = 0$$

$$A^2 - B^2 = 0$$

$$A = \pm B$$

$$|\vec{A}| = |\vec{B}|$$

Option (d) is correct.

27. Work ($= \vec{F} \cdot \vec{s}$) is a scalar quantity.

Option (d) is correct.

28. Speed $= |\vec{v}|$

Option (d) is correct.

29. $|\vec{A}| = 3$, $|\vec{B}| = 5$ and angle between \vec{A} and \vec{B} is 60° .

$$\therefore \vec{A} \cdot \vec{B} = |\vec{A}| |\vec{B}| \cos 60^\circ$$

$$= (3)(5) \left(\frac{1}{2}\right)$$

$$= 7.5$$

Option (b) is correct.

30. $\vec{A} + \vec{B} = \vec{C}$

$$\therefore (\vec{A} + \vec{B}) \cdot (\vec{A} + \vec{B}) = \vec{C} \cdot \vec{C}$$

$$\text{or } \vec{A} \cdot \vec{A} + 2\vec{A} \cdot \vec{B} + \vec{B} \cdot \vec{B} = \vec{C} \cdot \vec{C}$$

$$\text{or } A^2 + 2\vec{A} \cdot \vec{B} + B^2 = C^2$$

$$\text{or } \vec{A} \cdot \vec{B} = 0$$

$$\text{or } |\vec{A}| |\vec{B}| \cos \theta = 0$$

$$\text{or } \cos \theta = 0$$

$$\text{or } \theta = \frac{\pi}{2}$$

Option (d) is correct.

31. Magnetic field intensity.

Option (d) is correct.

32. $\vec{P} + \vec{Q} = \vec{R}$

$$(\vec{P} + \vec{Q}) \cdot (\vec{P} + \vec{Q}) = \vec{R} \cdot \vec{R}$$

$$P^2 + Q^2 + 2\vec{P} \cdot \vec{Q} = R^2$$

$$12^2 + 5^2 + 2\vec{P} \cdot \vec{Q} = 13^2$$

$$\vec{P} \cdot \vec{Q} = 0$$

∴ Angle between \vec{P} and $\vec{Q} = \frac{\pi}{2}$

Option (b) is correct.

33. Option (b) is correct.

34. $\vec{P} + \vec{Q} + \vec{R} = 0$

$$\therefore \vec{P} + \vec{Q} = -\vec{R}$$

$$\text{or } (\vec{P} + \vec{Q}) \cdot (\vec{P} + \vec{Q}) = (-\vec{R}) \cdot (-\vec{R})$$

$$\text{or } \vec{P} \cdot \vec{P} + \vec{Q} \cdot \vec{Q} + 2\vec{P} \cdot \vec{Q} = \vec{R} \cdot \vec{R}$$

$$\text{or } P^2 + Q^2 + 2\vec{P} \cdot \vec{Q} = R^2 \quad \dots(i)$$

$$\text{Let } Q^2 = P^2 \text{ and } R = P\sqrt{2}$$

Thus, Eq. (i) takes the form

$$P^2 + P^2 + 2PQ \cos \theta = 2P^2$$

$$\text{or } 2PQ \cos \theta = 0$$

8 | Mechanics-1

or $\cos \theta = 0$

or $\theta = 90^\circ$

\therefore Angle between \vec{P} and \vec{Q} is 90°

$$\vec{P} + \vec{Q} + \vec{R} = 0$$

$\therefore \vec{P} + \vec{R} = -\vec{Q}$

or $(\vec{P} + \vec{R}) \cdot (\vec{P} + \vec{R}) = (-\vec{Q}) \cdot (-\vec{Q})$

or $P^2 + R^2 + 2PR \cos \phi = Q^2$

or $2PR \cos \phi = Q^2 - P^2 - R^2$

or $2PR \cos \phi = -R^2$

or $2P \cos \phi = -R$

or $2P \cos \phi = -P\sqrt{2}$

or $\cos \phi = -\frac{1}{\sqrt{2}}$

$\therefore \phi = 135^\circ$

\therefore Angle between \vec{P} and \vec{R} is 135° .

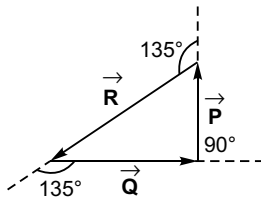

Option (a) is correct.

35. Angle (ϕ) between $\vec{P} + \vec{Q}$ and $\vec{P} - \vec{Q}$

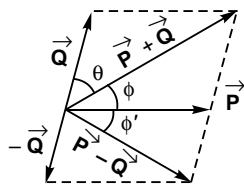

$$\tan \phi = \frac{Q \sin \theta}{P + Q \cos \theta}$$

Angle ϕ' between $\vec{P} - \vec{Q}$ and \vec{P}

$$\begin{aligned} \tan \phi' &= \frac{Q \sin(\pi + \theta)}{P + Q \cos(\pi + \theta)} \\ &= \frac{-Q \sin \theta}{P - Q \cos \theta} \end{aligned}$$

$$\tan[\phi + (-\phi')] = \frac{\tan \phi - \tan \phi'}{1 + \tan \phi \tan \phi'}$$

$$\begin{aligned} &= \frac{Q \sin \theta}{P + Q \cos \theta} - \frac{(-Q \sin \theta)}{P - Q \cos \theta} \\ &= \frac{Q \sin \theta}{(P + Q \cos \theta) \cdot (P - Q \cos \theta)} \\ &= \frac{2PQ \sin \theta}{P^2 + Q^2 \cos 2\theta} \end{aligned}$$

This implies that angle between $\vec{P} + \vec{Q}$ and $\vec{P} - \vec{Q}$ will vary from 0 to π .

Option (b) is correct.

36. $R^2 = P^2 + Q^2 + 2PQ \cos \theta$

for $R = P = Q$

$$P^2 = P^2 + P^2 + 2PP \cos \theta$$

or $\cos \theta = -\frac{1}{2}$

or $\theta = 120^\circ$

Option (b) is correct.

37. $W = \vec{F} \cdot \vec{s}$

$$= (3\hat{i} + 4\hat{j}) \cdot (3\hat{i} + 4\hat{j})$$

$$= 25 \text{ J}$$

Option (b) is correct.

38. $\vec{P} \cdot \vec{Q} = (a\hat{i} + a\hat{j} + 3\hat{k}) \cdot (a\hat{i} - 2\hat{j} - \hat{k})$

$$= a^2 - 2a - 3$$

For $\vec{P} \perp \vec{Q}$, $\vec{P} \cdot \vec{Q} = 0$

i.e., $a^2 - 2a - 3 = 0$

or $(a - 3)(a + 1) = 0$

$\Rightarrow a = 3$

Other value is -ive.

Option (d) is correct.

39. If a vector makes angles α , β and γ with the co-ordinate axes, then

$$\cos^2 \alpha + \cos^2 \beta + \cos^2 \gamma = 1$$

Now, $\left(\frac{3}{7}\right)^2 = \frac{9}{49}$, $\left(\frac{6}{7}\right)^2 = \frac{36}{49}$, $\left(\frac{2}{7}\right)^2 = \frac{4}{49}$

and $\frac{9}{49} + \frac{36}{49} + \frac{4}{49} = 1$

\therefore Option (a) is correct.

40. $\vec{A} = 4\hat{i} - 3\hat{j}$ and $\vec{B} = 8\hat{i} + 8\hat{j}$

$\therefore \vec{A} + \vec{B} = \vec{C} = 12\hat{i} + 5\hat{j}$

$$\hat{C} = \frac{\vec{C}}{|C|} = \frac{12\hat{i} + 5\hat{j}}{\sqrt{12^2 + 5^2}}$$

$$= \frac{12}{13}\hat{i} + \frac{5}{13}\hat{j}$$

Option (b) is correct.

41. $\vec{A} = 2\hat{i} + 3\hat{j} - 2\hat{k}, \vec{B} = 5\hat{i} + n\hat{j} + \hat{k},$

$$\vec{C} = -\hat{i} + 2\hat{j} + 3\hat{k}$$

∴ Vectors $\vec{A}, \vec{B},$ and \vec{C} will be coplanar if their scalar triple product is zero i.e.,

$$(\vec{A} \times \vec{C}) \cdot \vec{B} = 0$$

$$\begin{vmatrix} \hat{i} & \hat{j} & \hat{k} \\ 2 & 3 & -2 \\ -1 & 2 & 3 \end{vmatrix} \cdot (5\hat{i} + n\hat{j} + \hat{k}) = 0$$

or $(13\hat{i} - 4\hat{j} + 7\hat{k}) \cdot (5\hat{i} + n\hat{j} + \hat{k}) = 0$

or $65 - 4n + 7 = 0$

or $n = 18$

Option (a) is correct.

42. Option (a) is correct.

43. $(\vec{a} + \vec{b}) \times (\vec{a} - \vec{b})$

$$= \vec{a} \times \vec{a} + \vec{b} \times \vec{a} - \vec{a} \times \vec{b} - \vec{b} \times \vec{b}$$

$$= 0 - \vec{a} \times \vec{b} - \vec{a} \times \vec{b} - 0$$

$$= -2(\vec{a} \times \vec{b}) = 2(\vec{b} \times \vec{a})$$

Option (a) is correct.

44. $\vec{A} = 3\hat{i} + 4\hat{j} + 5\hat{k}$

$$\vec{B} = 3\hat{i} + 4\hat{j} - 5\hat{k}$$

$$\cos \theta = \frac{(\vec{A} \cdot \vec{B})}{|\vec{A}| |\vec{B}|}$$

$$= \frac{9 + 16 - 25}{3^2 + 4^2 + 5^2}$$

$$= 0$$

$$\Rightarrow \theta = 90^\circ$$

Option (c) is correct.

45. $A + B = 7$

$$A - B = 3$$

$$\therefore B = 2N$$

Option (c) is correct.

46. Angle between $\vec{A} = 2\hat{i} + 3\hat{j}$

and $\vec{B} = \hat{i} + \hat{j}$

$$\theta = \frac{\vec{A} \cdot \vec{B}}{|\vec{A}| |\vec{B}|} = \frac{2 + 3}{\sqrt{2^2 + 3^2} \cdot \sqrt{2}}$$

$$= \frac{5}{\sqrt{13} \cdot \sqrt{2}}$$

$$= \frac{5}{\sqrt{26}}$$

Component of \vec{A} along $\hat{i} + \hat{j}$

$$\vec{C} = \frac{5}{\sqrt{26}} (2\hat{i} + 3\hat{j})$$

$$|\vec{C}| = \frac{5}{\sqrt{2}}$$

Option (a) is correct.

47. $R^2 = (3P)^2 + (2P)^2 + 2 \times 3P \times 2P \cos \theta$

or $R^2 = 13P^2 + 12P^2 \cos \theta \dots(i)$

Further

$$(2R)^2 = (6P)^2 + (2P)^2 + 2 \times 6P \times 2P \cos \theta$$

or $4R^2 = 40P^2 + 24P^2 \cos \theta \dots(ii)$

Dividing Eq. (ii) by Eq. (i),

$$10P^2 + 6P^2 \cos \theta = 13P^2 + 12P^2 \cos \theta$$

or $6 \cos \theta = -P$

or $\theta = 120^\circ$

Option (b) is correct.

48. $\tan \theta = \frac{Q \sin \alpha}{P + Q \cos \alpha}$

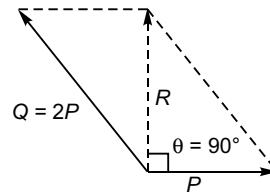

As $\theta = 90^\circ, \tan \alpha = \infty$

∴ $P + Q \cos \alpha = 0$

i.e., $\cos \alpha = -\frac{P}{Q}$

$$= -\frac{P}{2P}$$

10 | Mechanics-1

$$= -\frac{1}{2}$$

$$\therefore \alpha = 120^\circ$$

Option (a) is correct.

49. $\vec{A} \cdot \vec{B} = 0$

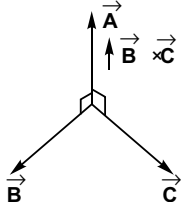

$$\Rightarrow \vec{A} \perp \vec{B} \quad \dots(i)$$

$$\vec{A} \cdot \vec{C} = 0$$

$$\Rightarrow \vec{A} \perp \vec{C} \quad \dots(ii)$$

From Eq. (i) and Eq. (ii), we conclude that \vec{A} is perpendicular to the plane containing \vec{B} and \vec{C} .

This implies that \vec{A} is perpendicular to $\vec{B} \cdot \vec{C}$.

Option (c) is correct.

50. $P^2 + Q^2 + 2PQ \cos \alpha = R^2$

or $P^2 + Q^2 + 2PQ \cos \alpha = 8^2$

or $P^2 + Q^2 + 2PQ + 2PQ \cos \alpha - 2PQ = 64$

or $(P + Q)^2 + 2PQ(\cos \alpha - 1) = 64$

or $(16)^2 + 2PQ(\cos \alpha - 1) = 64$

or $2PQ(\cos \alpha - 1) = -192$

or $PQ \cos \alpha - PQ = -96 \dots(i)$

$$\tan \theta = \frac{Q \sin \alpha}{P + Q \cos \alpha} = \infty \quad (\text{as})$$

$$\theta = 90^\circ$$

$$\therefore P + Q \cos \alpha = 0$$

$$Q \cos \alpha = -P \quad \dots(ii)$$

Using Eq. (ii) and Eq. (i),

$$P(-P) - PQ = -96$$

or $-P(P + Q) = -96$

or $-P \times 16 = -96$

$$P = +6 \text{ N}$$

$$\therefore Q = 10 \text{ N}$$

Option (a) is correct.

51. $|\vec{A} \times \vec{B}| = \sqrt{3} (\vec{A} \cdot \vec{B})$

$$\Rightarrow |\vec{A}| |\vec{B}| \sin \theta = \sqrt{3} |\vec{A}| |\vec{B}| \cos \theta$$

$$\Rightarrow \tan \theta = \sqrt{3}$$

$$\Rightarrow \theta = 60^\circ$$

$$\therefore |\vec{A} \times \vec{B}|^2 = |\vec{A}|^2 \times |\vec{B}|^2 + 2|\vec{A}| |\vec{B}| \cos \theta$$

$$= A^2 + B^2 + 2AB \cos 60^\circ$$

$$= A^2 + B^2 + AB$$

$$|\vec{A} \times \vec{B}| = [A^2 + B^2 + AB]^{1/2}$$

52. \vec{C} is perpendicular to both \vec{A} and \vec{B}

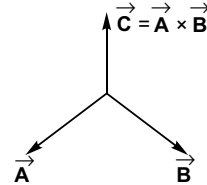

$$\therefore \vec{C} \cdot \vec{A} = 0$$

or $(\vec{A} \times \vec{B}) \cdot \vec{A} = 0$

Option (d) is correct.

53. $(2\hat{i} + 3\hat{j} + 8\hat{k}) \cdot (-4\hat{i} + 4\hat{j} + \alpha\hat{k}) = 0$

$$\Rightarrow -8 + 12 + 8\alpha = 0$$

$$\therefore \alpha = -\frac{1}{2}$$

Option (c) is correct.

54. $\vec{P} + \vec{Q} + \vec{R} = \vec{0}$

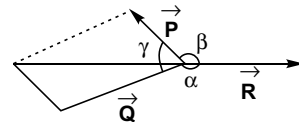

If, $\frac{|\vec{P}|}{\sin \alpha} = \frac{|\vec{Q}|}{\sin \beta} = \frac{|\vec{R}|}{\sin \gamma}$

55. $\vec{OA} + \vec{AB} = \vec{OB}$

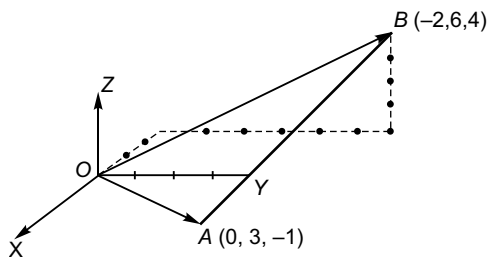

$$\begin{aligned} \therefore \vec{AB} &= \vec{OB} - \vec{OA} \\ &= (-2\hat{i} + 6\hat{j} + 4\hat{k}) - (0\hat{i} + 3\hat{j} - \hat{k}) \\ &= -2\hat{i} + 3\hat{j} + 5\hat{k} \end{aligned}$$

Option (c) is correct.

Match the Columns

1. (a) $|\vec{A} \times \vec{B}| = |\vec{A} \cdot \vec{B}|$

or $|\vec{A}| |\vec{B}| \sin \theta = \pm |\vec{A}| |\vec{B}| \cos \theta$

or $\tan \theta = \pm 1$
 $\Rightarrow \theta = \frac{\pi}{2}, \frac{3\pi}{4}$

Thus, (a) \rightarrow (r) (s).

(b) $\vec{A} \times \vec{B} = \vec{B} \times \vec{A}$ (given)

or $\vec{A} \times \vec{B} = -(\vec{B} \times \vec{A})$

or $|\vec{A}| |\vec{B}| \sin \theta = -|\vec{A}| |\vec{B}| \sin \theta$

or $\sin \theta = -\sin \theta$

or $2\sin \theta = 0$

$\Rightarrow \theta = 0 \text{ rad}$

Thus, (b) \rightarrow (p).

(c) $|\vec{A} \times \vec{B}| = |\vec{A} \cdot \vec{B}|$

or $|\vec{A} + \vec{B}|^2 = |\vec{A} - \vec{B}|^2$

56. Using answer to questions no. 35, as angle between $\vec{A} + \vec{B}$ and $\vec{A} - \vec{B}$ is 90°

$$A^2 + B^2 \cos 2\theta = 0$$

or $A^2 = -B^2 \cos 2\theta$

or $A^2 = -B^2 \cos 2\left(\frac{\pi}{2}\right) \quad \left(\because \theta = \frac{\pi}{2}\right)$

or $A^2 = -B^2 \cos \pi$

or $A^2 = B^2$

$\Rightarrow A = B$

Option (a) is correct.

$\Rightarrow (\vec{A} + \vec{B}) \cdot (\vec{A} + \vec{B}) = (\vec{A} - \vec{B}) \cdot (\vec{A} - \vec{B})$

or $\vec{A} \cdot \vec{A} + \vec{B} \cdot \vec{A} + \vec{B} \cdot \vec{A} + \vec{B} \cdot \vec{B}$

$= \vec{A} \cdot \vec{A} - \vec{B} \cdot \vec{A} - \vec{A} \cdot \vec{B} + \vec{B} \cdot \vec{B}$

or $4\vec{A} \cdot \vec{B} = 0$

$\Rightarrow \vec{A} \perp \vec{B}$

Thus, (c) \rightarrow (q).

(d) $\vec{A} + \vec{B} = \vec{C}$

or $(\vec{A} + \vec{B}) \cdot (\vec{A} + \vec{B}) = \vec{C} \cdot \vec{C}$

or $\vec{A} \cdot \vec{A} + \vec{B} \cdot \vec{A} + \vec{B} \cdot \vec{A} + \vec{B} \cdot \vec{B} = \vec{C} \cdot \vec{C}$

or $A^2 + 2\vec{A} \cdot \vec{B} + B^2 = C^2$

or $2\vec{A} \cdot \vec{B} = 0 \quad (\because A^2 + B^2 = C^2)$

$\Rightarrow \vec{A} \perp \vec{B}$

Thus, (d) \rightarrow (q).

Section II

Subjective Questions

1. $2 \times 10^{11} \text{ N/m}^2 = \frac{(2 \times 10^{11})(10^5 \text{ dyne})}{(10^4 \text{ cm}^2)}$

$= 2 \times 10^{12} \text{ dyne/cm}^2$

2. $72 \text{ dyne/cm} = \frac{(72)(10^{-5} \text{ N})}{(10^{-2} \text{ m})} = 0.072 \text{ N/m}$

3. $[a] = [y] = [L]$

$[\omega t] = [M^0 L^0 T^0] \quad \therefore [\omega] = [T^{-1}]$

$[\theta] = [M^0 L^0 T^0]$

4. $h = \frac{E}{v} = \frac{J}{\text{per sec}} = \text{J-s}$

$[h] = [ML^2 T^{-2}] [T] = [ML^2 T^{-1}]$

5. $[b] = [x^2] = [L^2]$

12 | Mechanics-1

$$\left[\frac{b}{at}\right] = [p]$$

$$\therefore [a] = \left[\frac{b}{tp}\right] = \left[\frac{L^2}{TML^2T^{-3}}\right] = [M^{-1}T^2]$$

$$\begin{aligned} 6. S_t &= \left(ut + \frac{1}{2}at^2\right) - \left[u(t-1) + \frac{1}{2}a(t-1)^2\right] \\ &= u \cdot 1 - \frac{1}{2}a(1)^2 + at(1) = u + at - \frac{1}{2}a \\ &= u + \frac{a}{2}(2t-1) \end{aligned}$$

Here t in second. Hence the given equation seems to be dimensionally incorrect. But it is correct because 1 is hidden.

7. LHS is dimensionless. While RHS has the dimensions $[L^{-1}]$.

8. LHS is dimensionless. Hence $n = 0$.

9. Just write the dimension of different physical quantities.

$$10. E = km^x n^y a^z.$$

Here k = a dimensionless constant

$$\therefore [E] = [m]^x [n]^y [a]^z$$

$$\therefore [ML^2T^{-2}] = [M]^x [T^{-1}]^y [L]^z$$

$$\therefore x = 1, y = 2 \text{ and } z = 2$$

$$11. F = km^x v^y r^z$$

(k = a dimensionless constant)

$$[F] = [m]^x [v]^y [r]^z$$

$$\therefore [MLT^{-2}] = [M]^x [LT^{-1}]^y [L]^z$$

Solving we get,

$$x = 1, y = 2 \text{ and } z = -1$$

$$\therefore F = \frac{kmv^2}{r}$$

$$12. (a) [d] = [F]^x [L]^y [T]^z$$

$$\therefore [ML^{-3}] = [MLT^{-2}]^x [L]^y [T]^z$$

Equating the powers we get,

$$x = 1, y = -4, z = 2$$

$$\therefore [d] = [FL^{-4}T^2]$$

Similarly other parts can be solved.

$$\begin{aligned} 13. \cos \theta &= \frac{\vec{A} \cdot \vec{B}}{AB} = \frac{6-2+8}{\sqrt{9+1+4}\sqrt{4+4+16}} \\ &= \frac{12}{\sqrt{336}} = \frac{3}{\sqrt{21}} \end{aligned}$$

$$14. \vec{A} + \vec{B} = \vec{R} \text{ (say)} = 3\hat{i} + \hat{j}$$

$$\vec{A} - \vec{B} = \vec{S} \text{ (say)} = \hat{i} + 5\hat{j}$$

Angle between \vec{R} and \vec{S}

$$\cos \theta = \frac{\vec{R} \cdot \vec{S}}{RS} = \frac{3+5}{\sqrt{9+1}\sqrt{1+25}} = \frac{8}{\sqrt{260}} = \frac{4}{\sqrt{65}}$$

$$\therefore \theta = \cos^{-1}\left(\frac{4}{\sqrt{65}}\right)$$

15. Their dot product should be zero.

16. Ratio of coefficients of \hat{i} , \hat{j} and \hat{k} should be same.

17. No solution is required.

18. Component of \vec{A} along $\vec{B} = A \cos \theta = \frac{\vec{A} \cdot \vec{B}}{B}$

$$19. \vec{A} + \vec{B} = \vec{R} = 5\hat{i} - \hat{j} + \hat{k}$$

$$\hat{R} = \frac{\vec{R}}{R}$$

$$20. \vec{A} \times \vec{B} = \vec{C} \text{ (say)} = -3\hat{i} + 8\hat{j} + 2\hat{k}$$

$$\text{Now } \vec{A} \cdot \vec{C} = -6 + 8 - 2 = 0$$

$$\therefore \vec{A} \perp \vec{C}$$

$$\vec{B} \cdot \vec{C} = 0 + 8 - 8 = 0$$

$$\therefore \vec{B} \perp \vec{C}$$

21. Area of parallelogram = $|\vec{A} \times \vec{B}|$

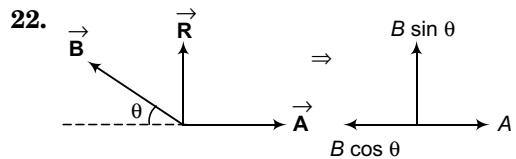

$$B \sin \theta = R = \frac{B}{2}$$

$$\therefore \theta = 30^\circ$$

\therefore Angle between \vec{A} and $\vec{B} = 180 - \theta = 150^\circ$

$$23. \vec{A} + \vec{B} = (4\hat{i} + 6\hat{j}) + \vec{B} = 10\hat{i} + 9\hat{j}$$

$$\therefore \vec{B} = (6\hat{i} + 3\hat{j})$$

24.

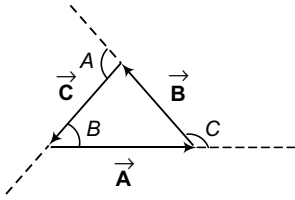

Applying sine law, we have

$$\frac{a}{\sin(180 - A)} = \frac{b}{\sin(180 - B)}$$

$$= \frac{c}{\sin(180 - C)}$$

$$\text{or } \frac{a}{\sin A} = \frac{b}{\sin B} = \frac{c}{\sin C}$$

25.

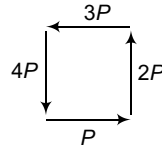

$$\vec{R} = P\hat{i} + 2P\hat{j} - 3P\hat{i} - 4P\hat{j}$$

$$= (-2P\hat{i} - 2P\hat{j})$$

26.

$$R^2 = P^2 + Q^2 + 2PQ \cos \theta$$

$$S^2 = P^2 + Q^2 - 2PQ \cos \theta$$

$$\therefore R^2 + S^2 = 2(P^2 + Q^2)$$

3

Motion in One Dimension

Introductory Exercise 3.1

1. Suppose a particle is moving with constant velocity v (along the axis of x).

Displacement of particle in time $t_1 = vt_1$

Displacement of particle in time $t_2 = vt_2$

\therefore Displacement of the particle in the time interval $\Delta t (= t_2 - t_1)$

$$= vt_2 - vt_1$$

$$= v(t_2 - t_1)$$

\therefore Average velocity in the time interval

$$\Delta t' = \frac{v(t_2 - t_1)}{(t_2 - t_1)}$$

$$= v$$

Now, as the particle is moving with constant velocity (*i.e.*, with constant speed in a given direction) its velocity and speed at any instant will obviously be v .

Ans. True.

2. As the stone would be free to acceleration under earth's gravity it acceleration will be g .
3. A second hand takes 1 min *i.e.*, 60s to complete one rotation (*i.e.*, rotation by an angle of 2π rad).

\therefore Angular speed of second hand

$$= \frac{2\pi \text{ rad}}{60 \text{ s}}$$

$$= \frac{\pi}{30} \text{ rad s}^{-1}$$

Linear speed of its tip = radius \times angular speed

$$= 2.0 \text{ cm} \times \frac{\pi}{30} \text{ rad s}^{-1}$$

$$= \frac{\pi}{15} \text{ cms}^{-1}$$

As the tip would be moving with constant speed.

$$\text{Average speed} = \frac{\pi}{15} \text{ cms}^{-1}$$

In 15 s the second hand would rotate through 90° *i.e.*, the displacement of its tip will be $r\sqrt{2}$.

\therefore Modulus of average velocity of the tip of second hand in 15 s.

$$\begin{aligned} &= \frac{r\sqrt{2}}{15} \\ &= \frac{2\sqrt{2}}{15} \text{ cms}^{-1} \end{aligned}$$

4. (a) Yes. By changing direction of motion, there will be change in velocity and so acceleration.
- (b) (i) No. In curved path there will always be acceleration. (As explained in the previous answer no. 3)
- (ii) Yes. In projectile motion the path of the particle is a curved one while acceleration of the particle remains constant.
- (iii) Yes. In curved path the acceleration will always be there. Even if the path is circular with constant speed the direction of the acceleration of the particle would every time be changing.

5. (a) Time speed = $\frac{\text{Circumference}}{\text{Speed}}$
 $= \frac{2\pi \times 4 \text{ cm}}{1 \text{ cm/s}} = 8\pi = 25.13 \text{ s}$

(b) As particle is moving with constant speed of 1 cm/s, its average speed in any time interval will be 1 cm/s.

$$|\text{Average velocity}| = \frac{r\sqrt{2}}{T/4}$$

$$= \frac{4r\sqrt{2}}{\left(\frac{2\pi r}{\text{speed}}\right)} = \frac{2\sqrt{2}}{\pi} \text{ speed}$$

$$= \frac{2\sqrt{2}}{\pi} \text{ cms}^{-1}$$

$$= 0.9 \text{ cms}^{-1}$$

$$|\text{Average acceleration}| = \frac{v\sqrt{2}}{T/4}$$

(where $v = \text{speed}$)

$$= \frac{4v\sqrt{2}}{2\pi r}$$

$$= \frac{2\sqrt{2}}{\pi} \frac{v^2}{r}$$

$$= \frac{2\sqrt{2}}{\pi} \frac{(1)^2}{4}$$

$$= 0.23 \text{ cm s}^{-2}$$

6. Distance = Speed \times time

$$D_1 = v_1 t_1$$

$$D_2 = v_2 t_2$$

$$\text{Average speed} = \frac{D_1 + D_2}{t_1 + t_2} = \frac{v_1 t_1 + v_2 t_2}{t_1 + t_2}$$

$$= \frac{(4 \times 2) + (6 \times 3)}{2 + 3}$$

$$= 5.2 \text{ ms}^{-1}$$

Introductory Exercise 3.2

- Acceleration (due to gravity).
- $s_t = u + at - \frac{1}{2}a$ is physically correct as it gives the displacement of the particle in t^{th} second (or any time unit).
 $s_t = \text{Displacement in } t \text{ seconds}$

$$- \text{displacement in } (t - 1) \text{ seconds}$$

$$= \left[ut + \frac{1}{2}at^2 \right] - \left[u(t - 1) + \frac{1}{2}a(t - 1)^2 \right]$$

$$st = u + at - \frac{1}{2}a$$

Therefore, the given equation is dimensionally incorrect.

- Yes. When a particle executing simple harmonic motion returns from maximum amplitude position to its mean position the value of its acceleration decreases while speed increases.

- $v = t^{3/4}$ (given)
 $\frac{ds}{dt} = t^{3/4}$... (i)

$$\therefore s = \int t^{3/4} dt = \frac{t^{3/4+1}}{\frac{3}{4}+1} + c$$

or $s = \frac{4}{7}t^{7/4} + c$

i.e., $s \propto t^{7/4}$

Differentiating Eq. (i) w.r.t. time t ,

$$\frac{d^2s}{dt^2} = \frac{3}{4}t^{3/4-1}$$

$$\Rightarrow a \propto t^{-1/4}$$

- Displacement (s) of the particle

$$s = (40 \times 6) + \frac{1}{2}(-10)6^2$$

$$= 240 - 180$$

$$= 60\text{m (in the upward direction)}$$

Distance covered (D) by the particle

Time to attain maximum height

16 | Mechanics-1

$$= \frac{40}{10} = 4 \text{ s} < 6 \text{ s}$$

It implies that particle has come back after attaining maximum height (h) given by

$$h = \frac{u^2}{2g}$$

$$= \frac{(40)^2}{2 \times 10} = 80 \text{ m}$$

$$\therefore D = 80 + (80 - 60)$$

$$= 100 \text{ m}$$

6. $v = 40 - 10t$

$$\therefore \frac{dx}{dt} = 40 - 10t$$

or $dx = (40 - 10t) dt$

or $x = \int (40 - 10t) dt$

or $x = 40t - 5t^2 + c$

As at $t = 0$ the value of x is zero.

$$c = 0$$

$$\therefore x = 40t - 5t^2$$

For x to be 60 m.

$$60 = 40t - 5t^2$$

or $t^2 - 8t + 12 = 0$

$$\therefore t = 2 \text{ s or } 6 \text{ s}$$

7. Average velocity = $\frac{\text{Displacement in time } t}{t}$

$$= \frac{ut + \frac{1}{2}at^2}{t}$$

$$= u + \frac{1}{2}at$$

8. $v_2 = v_1 + at$

$$\therefore at = v_2 - v_1$$

Average velocity = $\frac{\text{Displacement in time } t}{t}$

$$= \frac{v_1 t + \frac{1}{2}at^2}{t}$$

$$= v_1 + \frac{1}{2}at$$

$$= v_1 + \frac{v_2 - v_1}{2}$$

$$= \frac{v_1 + v_2}{2}$$

\therefore **Ans.** True.

9. $125 = 0 \cdot t + \frac{1}{2}gt^2$

$$\Rightarrow t = 25 \text{ s}$$

Average velocity = $\frac{125 \text{ m}}{5 \text{ s}}$ (downwards)

$$= 25 \text{ m/s}$$
 (downwards)

10. $v = 10 + 5t - t^2$... (i)

$$\therefore a = \frac{dv}{dt} = 5 - 2t$$

At $t = 2 \text{ s}$

$$a = 5 - 2 \times 2$$

$$= 1 \text{ m/s}^2$$

From Eq. (i),

$$\frac{dx}{dt} = 10 + 5t - t^2$$

$$\therefore x = \int (10 + 5t - t^2) dt$$

or $x = 10t + \frac{5t^2}{2} - \frac{t^3}{3} + c$

As, at $t = 0$ the value of x is zero

$$c = 0$$

$$\therefore x = 10t + \frac{5}{2}t^2 - \frac{t^3}{3}$$

Thus, at $t = 3 \text{ s}$

$$x = (10 \times 3) + \frac{5}{2}(3)^2 - \frac{3^3}{3}$$

$$= 30 + 22.5 - 9$$

$$= 43.5 \text{ m}$$

11. $\vec{u} = 2 \hat{i} \text{ m/s}$

$$\vec{a} = (2 \cos 60^\circ \hat{i} + 2 \sin 60^\circ \hat{j}) \text{ m/s}^2$$

$$= (1 \hat{i} + \sqrt{3} \hat{j}) \text{ m/s}^2$$

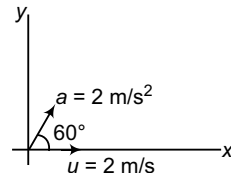

$$\vec{v} = \vec{u} + \vec{a} t$$

$$= 2 \hat{i} + (1 \hat{i} + \sqrt{3} \hat{j}) 2$$

$$= 4 \hat{i} + 2\sqrt{3} \hat{j}$$

$$|\vec{v}| = \sqrt{4^2 + 12} = 2\sqrt{7} \text{ m/s}$$

$$\vec{s} = \vec{u}t + \frac{1}{2}\vec{a}t^2$$

$$= (2\hat{i})2 + \frac{1}{2}(1\hat{i} + \sqrt{3}\hat{j})2^2$$

$$= 4\hat{i} + 2\hat{i} + 2\sqrt{3}\hat{j}$$

$$= 6\hat{i} + 2\sqrt{3}\hat{j}$$

$$\therefore |\vec{s}| = \sqrt{36 + 12}$$

$$= 4\sqrt{3} \text{ m}$$

12. Part I $\vec{v} = (2\hat{i} + 2t\hat{j})\text{m/s}$... (i)

$$\frac{d\vec{v}}{dt} = 2\hat{j}$$

$$\vec{a} = 2\hat{j} \text{ m/s}^2$$

From Eq. (i),

$$\frac{d\vec{s}}{dt} = (2\hat{i} + 2t\hat{j})$$

$$\therefore \vec{s} = \int (2\hat{i} + 2t\hat{j}) dt$$

$$\vec{s} = 2t\hat{i} + t^2\hat{j} + c$$

Taking initial displacement to be zero.

$$\vec{s} \text{ (at } t = 1 \text{ s)} = (2\hat{i} + \hat{j}) \text{ m}$$

Part II Yes. As explained below.

$\vec{v} = 2\hat{i} + 2t\hat{j}$ implies that initial velocity of the particle is $2\hat{i} \text{ m/s}^2$ and the acceleration is $2\hat{j} \text{ m/s}^2$

$$\therefore \vec{s} \text{ (at } t = 1 \text{ s)} = (2\hat{i} \times 1) + \frac{1}{2}(2\hat{j})1^2$$

$$= (2\hat{i} + \hat{j}) \text{ m}$$

13. $x = 2t$ and $y = t^2$

$$\therefore y = \left(\frac{x}{2}\right)^2$$

or, $x^2 = 4y$

(The above is the equation to trajectory)

$$x = 2t$$

$$\therefore \frac{dx}{dt} = 2 \text{ i.e., } \vec{v}_x = 2\hat{i}$$

$$y = t^2$$

$$\therefore \frac{dy}{dt} = 2t \text{ i.e., } \vec{v}_y = 2t\hat{j}$$

Thus, $\vec{v} = \vec{v}_x + \vec{v}_y$

$$= (2\hat{i} + 2t\hat{j}) \text{ m/s}$$

$$\vec{a} = \frac{d\vec{v}}{dt} = 2\hat{j} \text{ m/s}^2$$

Introductory Exercise 3.3

1. At $t = t_1$

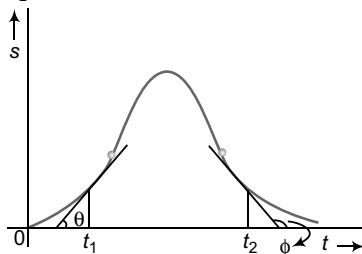

$$v = \tan \theta$$

As $\theta < 90^\circ$, v_{t_1} is + ive.

At $t = t_2$

$$v_{t_2} = \tan \phi$$

As $\phi > 90^\circ$, v_{t_2} is - ive.

Corresponding v - t graph will be

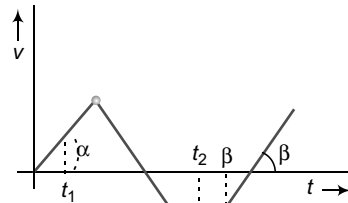

Acceleration at $t = t_1$:

$$a_{t_1} = \tan \alpha$$

As $\alpha < 90^\circ$, a_{t_1} is + ive constant.

Acceleration at $t = t_2$

$$a_{t_2} = \tan \beta$$

As $\beta < 90^\circ$, a_{t_2} is + ive constant.

2. Let the particle strike ground at time t
velocity of particle when it touches ground

18 | Mechanics-1

would be gt . KE of particle will be $\frac{1}{2}mg^2t^2$ i.e., $KE \propto t^2$. While going up the velocity will get -ive but the KE will remain. KE will reduce to zero at time $2t$ when the particle reaches its initial position.

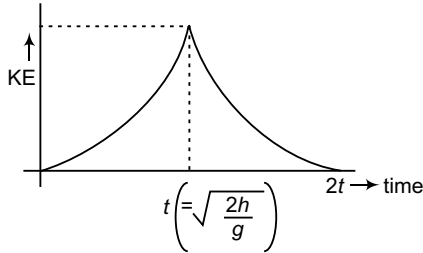

$$KE = \frac{1}{2}mg^2t^2 = \frac{1}{2}mg^2 \frac{2h}{g} = mgh$$

3. Speed of ball (just before making first collision with floor)

$$= \sqrt{2gh} = \sqrt{2 \times 10 \times 80} = 40 \text{ m/s}$$

Time taken to reach ground

$$= \sqrt{\frac{2h}{g}} = \sqrt{\frac{2 \times 80}{10}} = 4 \text{ s}$$

Speed of ball (just after first collision with floor)

$$= \frac{40}{2} = 20 \text{ m/s}$$

Time to attain maximum height

$$t = \frac{-20}{-10} = 2 \text{ s}$$

∴ Time for the return journey to floor = 2 s.

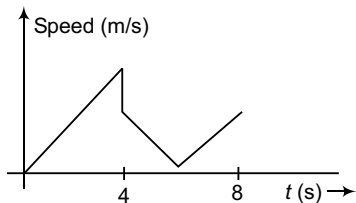

Corresponding velocity-time will be

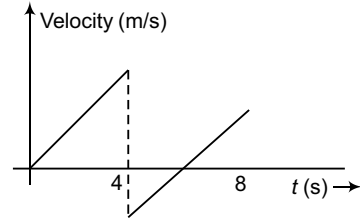

$$4. \frac{h}{(t-2)} = \tan \theta = \frac{2}{(2-1)}$$

$$\Rightarrow h = 2(t-2)$$

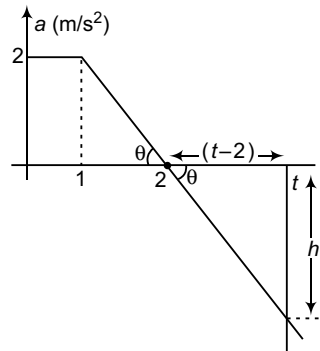

Particle will attain its initial velocity i.e., net increase in velocity of the particle will be zero when,

$$\text{area under } a-t \text{ graph} = 0$$

$$\frac{(1+2) \times 2}{2} + \frac{(-h)(t-2)}{2} = 0$$

$$\text{or } 3 - (t-2)^2 = 0$$

$$\text{or } (t-2)^2 = 3$$

$$\text{or } t-2 = \pm \sqrt{3}$$

$$\text{or } t = 2 \pm \sqrt{3}$$

Ans . At time $t = 2 + \sqrt{3}$ s

($t = 2 - \sqrt{3}$ not possible).

Introductory Exercise 3.4

1. Relative acceleration of A w.r.t. B

$$a_{AB} = (+g) - (+g) = 0$$

2. Velocity of A w.r.t. B = $v_A - v_B$

∴ Relative displacement (i.e., distance between A and B) would be

$$s = (v_A - v_B)t + \frac{1}{2}a_{AB}t^2$$

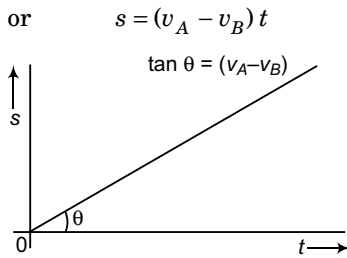

3. In figure, u = speed of boat
 v = speed of river flow

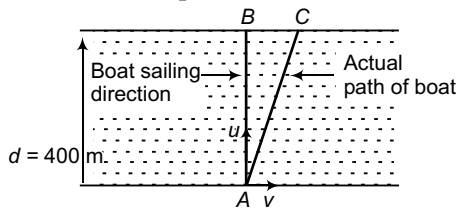

Time to cross river

$$= \frac{AB}{u} \left\{ = \frac{BC}{v} = \frac{AC}{\sqrt{u^2 + v^2}} \right\}$$

$$= \frac{400 \text{ m}}{10 \text{ m/s}}$$

$$= 40 \text{ s}$$

$$BC = \frac{v}{u} AB$$

$$= \frac{2 \text{ m/s}}{10 \text{ m/s}} \times (400 \text{ m})$$

$$= 80 \text{ m}$$

4. Let C be the point along which pilot should head the plane.

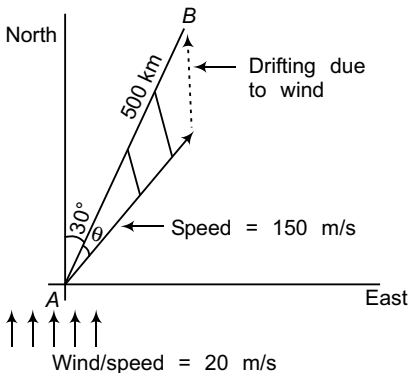

Apply sine formula in ΔABC

$$\frac{\sin 30^\circ}{150 t} = \frac{\sin \theta}{20 t} = \frac{\sin (180^\circ - 30^\circ + \theta)}{500 \times 10^3}$$

$$\frac{1}{300} = \frac{\sin \theta}{20}$$

$$\theta = \sin^{-1} \left(\frac{1}{15} \right)$$

Now $\frac{1}{300 t} = \frac{\sin (30^\circ + \theta)}{500 \times 10^3}$

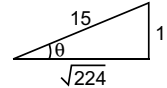

or $\frac{5000}{3 t} = \sin 30^\circ \cos \theta + \cos 30^\circ \sin \theta$

$$\frac{5000}{3 t} = \frac{1}{2} \frac{\sqrt{224}}{15} + \frac{\sqrt{3}}{2} \cdot \frac{1}{15}$$

or $\frac{5000}{3 t} = 0.5577$

$$\Rightarrow t = \frac{5000}{3 \times 0.5577}$$

$$= 2989 \text{ s}$$

$$= 50 \text{ min}$$

- 5.

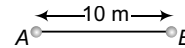

$$a_A = 1 \text{ m/s}^2, \quad a_B = 2 \text{ m/s}^2$$

$$v_A = 3 \text{ m/s}, \quad v_B = 1 \text{ m/s}$$

Acceleration of A w.r.t. $B = 1 - 2 = -1 \text{ m/s}^2$

Velocity of A w.r.t. $B = 3 - 1 = 2 \text{ m/s}$

Initial displacement of A w.r.t. $B = -10 \text{ m}$

At time relative displacement of A w.r.t. B

$$s = -10 + 2t + \frac{1}{2}(-1)t^2$$

or $s = -10 + 2t - 0.5t^2$

For s to be minimum

$$\frac{ds}{dt} = 0$$

or $2 - (0.5 \times 2t) = 0$

i.e., $t = 2 \text{ s}$

$$\therefore s_{\min} = -10 + (2 \times 2) - 0.5 \times (2)^2$$

$$= -10 + 4 - 2$$

$$= -8 \text{ m}$$

Minimum distance between A and $B = 8 \text{ m}$.

AIEEE Corner

Subjective Questions (Level 1)

1. (a) $D = v_1 t_1 + v_2 t_2$
 $= \left(60 \frac{\text{km}}{\text{h}} \times 1 \text{ h}\right) + \left(80 \frac{\text{km}}{\text{h}} \times \frac{1}{2} \text{ h}\right)$
 $= 100 \text{ km}$

(b) Average speed
 $= \frac{100 \text{ km}}{1.5 \text{ h}} = 66.67 \text{ km/h.}$

2. (a) Displacement in first two seconds
 $= (4)(2) + \frac{1}{2}(6)2^2$
 $= 20 \text{ m}$

\therefore Average velocity $= \frac{20 \text{ m}}{2 \text{ s}} = 10 \text{ m/s}$

(b) Displacement in first four seconds
 $= (4)(4) + \frac{1}{2}(6)4^2 = 64 \text{ m}$

\therefore Displacement in the time interval
 $t = 2 \text{ s to } t = 4 \text{ s}$
 $= 64 - 20$
 $= 44 \text{ m}$

\therefore Average velocity $= \frac{44 \text{ m}}{2 \text{ s}} = 22 \text{ m/s.}$

3. Let the particle takes t time to reach ground.

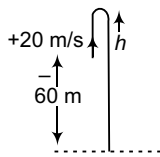

$\therefore -64 = 20t + \frac{1}{2}(-10)t^2$

i.e., $5t^2 - 20t - 64 = 0$
 $t = 6.1 \text{ s}$

If the particle goes h meter above tower before coming down

$0 = (20)^2 + 2(-10)h$
 $\Rightarrow h = 20 \text{ m}$

(a) Average speed $= \frac{\text{Total distance moved}}{\text{Time taken}}$
 $= \frac{(20 + 20 + 60)}{6.1} = 16.4 \text{ m/s}$

(b) Average velocity $= \frac{\text{Net displacement}}{\text{Time taken}}$
 $= \frac{-60 \text{ m}}{6.1 \text{ s}}$

$= -9.8 \text{ m/s}$
 $= 9.8 \text{ m/s}$ (downwards)

4. Average velocity $= \frac{\Sigma vt}{\Sigma t}$
 $2.5v = \frac{vt_0 + 2vt_0 + 3vT}{t_0 + t_0 + T}$

$\therefore 5t_0 + 2.5T = 3t_0 + 3T$
 or $T = 4t_0$

5. (a) Average acceleration
 $= \frac{\text{Final velocity} - \text{initial velocity}}{(4 + 8) \text{ s}}$

$= \frac{0 - 0}{12}$
 $= 0 \text{ m/s}^2$

(c) $a = \tan \theta = \frac{v_{\text{max}}}{4}$

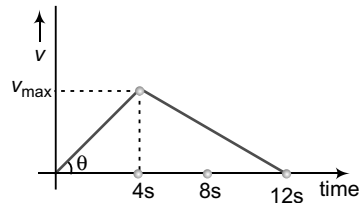

$\therefore 4 = \frac{v_{\text{max}}}{4}$ ($\because a = 4 \text{ m/s}^2$)

i.e., $v_{\text{max}} = 16 \text{ m/s}$

Displacement of particle in 12 seconds

$= \text{Area under } v-t \text{ graph}$

$= 12 \times \frac{v_{\text{max}}}{2}$
 $= \frac{12 \times 16}{2}$

$= 96 \text{ m}$

Average velocity

$= \frac{\text{Displacement (96 m) at 12s}}{\text{Time (12s)}}$

$= +8 \text{ m/s}$

(b) As the particle did not return back distance travelled in 12 s

$$= \text{Displacement at 12 s}$$

\therefore Average speed = 8 m/s.

6. (a) Radius (R) of circle = $\frac{21}{22}$ m

$$\begin{aligned} \therefore \text{Circumference of circle} &= 2\pi R \\ &= 2 \times \frac{22}{7} \times \frac{21}{22} \text{ m} \\ &= 6 \text{ m} \end{aligned}$$

Speed (v) of particle = 1 m/s

\therefore Distance moved by particle in 2 s = 2 m

Thus, angle through which the particle moved

$$= \frac{2}{6} \times 2\pi = \frac{2\pi}{3} = 120^\circ$$

$$\begin{aligned} \text{Magnitude of Average velocity} \\ &= \frac{\text{Magnitude of displacement}}{\text{Time} (= 2 \text{ s})} \end{aligned}$$

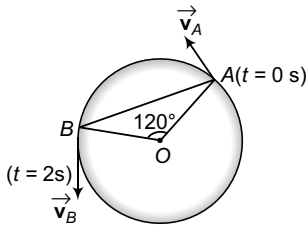

$$\begin{aligned} &= \frac{AB}{2} = \frac{2R \sin 60^\circ}{2} \\ &= R \frac{\sqrt{3}}{2} \\ &= \frac{21}{22} \frac{\sqrt{3}}{2} = \frac{21\sqrt{3}}{44} \text{ m/s} \end{aligned}$$

(b) Magnitude of average acceleration

$$\begin{aligned} &= \left| \frac{\vec{v}_B - \vec{v}_A}{2 \text{ s}} \right| \\ &= \frac{2v \sin \frac{120^\circ}{2}}{2} \end{aligned}$$

$$\begin{aligned} \therefore |\vec{v}_A| &= |\vec{v}_B| = v = 1 \text{ m/s} \\ &= v \sin 60^\circ \\ &= \frac{\sqrt{3}}{2} \text{ m/s}^2 \end{aligned}$$

7. Position vector at $t = 0$ s

$$\vec{r}_1 = (1\hat{i} + 2\hat{j}) \text{ m}$$

Position vector at $t = 4$ s

$$\vec{r}_2 = (6\hat{i} + 4\hat{j}) \text{ m}$$

(a) Displacement from $t = 0$ s to $t = 4$ s

$$\begin{aligned} &= (\vec{r}_2 - \vec{r}_1) \\ &= (6\hat{i} + 4\hat{j}) - (1\hat{i} + 2\hat{j}) \\ &= (5\hat{i} + 2\hat{j}) \text{ m} \end{aligned}$$

$$\therefore \text{Average velocity} = \frac{(5\hat{i} + 2\hat{j}) \text{ m}}{4 \text{ s}}$$

$$= (1.25\hat{i} + 0.5\hat{j}) \text{ m/s}$$

(b) Average acceleration

$$= \frac{\text{Final velocity} - \text{Initial velocity}}{4 \text{ s}}$$

$$= \frac{(2\hat{i} + 10\hat{j}) - (4\hat{i} + 6\hat{j})}{4}$$

$$= \frac{-2\hat{i} + 4\hat{j}}{4}$$

$$= (-0.5\hat{i} + \hat{j}) \text{ m/s}^2$$

(c) We cannot find the average speed as the actual path followed by the particle is not known.

Uniform acceleration

(a) One dimensional motion

8. If at time t the vertical displacement between A and B is 10 m

$$\frac{1}{2}gt^2 - \frac{1}{2}g(t-1)^2 = 10$$

$$\text{or } t^2 - (t-1)^2 = 2$$

$$\text{or } t^2 - (t^2 - 2t + 1) = 2$$

$$\text{or } 2t = 3$$

$$t = 1.5 \text{ s}$$

9. The two bodies will meet if

$$\begin{array}{l} \text{Displacement of} \\ \text{first after attaining} \\ \text{highest point} \end{array} = \begin{array}{l} \text{Displacement of} \\ \text{second before} \\ \text{attaining highest} \\ \text{point} \end{array}$$

22 | Mechanics-1

$$v_0 t - \frac{1}{2} g t^2 = v_0(t - t_0) - \frac{1}{2} g(t - t_0)^2$$

or $0 = -v_0 t_0 - \frac{1}{2} g(t_0^2 - 2t_0 t)$

or $g t_0 t = \frac{1}{2} g t_0^2 + v_0 t_0$

or $t = \frac{\frac{1}{2} g t_0 + v_0}{g}$

$$= \frac{t_0}{2} + \frac{v_0}{g}$$

10. $5 = \frac{1}{2} g t^2$

$\Rightarrow t = 1 \text{ s}$

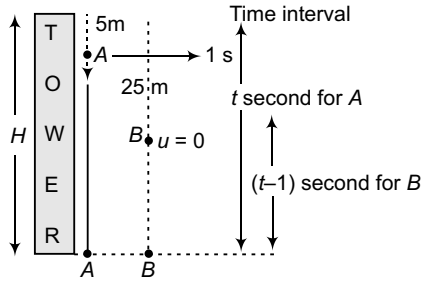

For A

$$H = 0 \cdot t + \frac{1}{2} g t^2$$

or $H = \frac{1}{2} g t^2 \quad \dots(i)$

For B

$$H - 25 = \frac{1}{2} g(t - 1)^2 \quad \dots(ii)$$

or $\frac{1}{2} g t^2 - \frac{1}{2} g(t - 1)^2 = 25$

[Substituting value of H from Eq. (i)]

$$\frac{1}{2} g[t^2 - (t - 1)^2] = 25$$

$$t^2 - (t^2 - 2t + 1) = 5$$

$$2t - 1 = 5$$

$\Rightarrow t = 3 \text{ s}$

Substituting $t = 3 \text{ s}$ in Eq. (i)

$$H = \frac{1}{2} \times 10 \times 3^2 = 45 \text{ m}$$

11. $s = \frac{1}{2} a t_0^2$ **Forward motion**

$v = a t_0$ **Backward motion**

$$-s = (a t_0) t + \frac{1}{2} (-a) t^2$$

$\therefore -\frac{1}{2} a t_0^2 = (a t_0) t - \frac{1}{2} a t^2$

or $-t_0^2 = 2 t_0 t - t^2$

or $t^2 - 2 t_0 t - t_0^2 = 0$

$$t = \frac{2 t_0 \pm \sqrt{(-2 t_0)^2 - 4(-1)(-t_0^2)}}{2}$$

$$= \frac{2 t_0 \pm 2 t_0 \sqrt{2}}{2}$$

$= t_0 + t_0 \sqrt{2}$ (-ive sign being absurd)

$$= (1 + \sqrt{2}) t_0$$

$$= 2.141 t_0$$

From the beginning of the motion the point mass will return to the initial position after time $3.141 t_0$.

12. $5^2 = u^2 + 2(-10)15$

$\Rightarrow u^2 = 325$

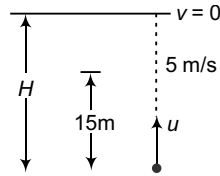

(a) **For H**

$$0^2 = u^2 + 2(-10) H$$

i.e., $20H = 325$

or $H = 16.25 \text{ m}$

(b) **For t**

$$0 = \sqrt{325} + (-10) t$$

$\therefore t = \frac{\sqrt{325}}{10}$

$$= 1.8 \text{ s}$$

13. At rest \xrightarrow{a} \xrightarrow{u} \xrightarrow{a} 15 m/s

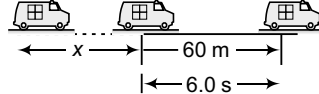

(a) $15^2 = u^2 + 2a \times 60 \quad \dots(i)$

and $15 = u + a \times 6 \quad \dots(ii)$

Substituting the value of $6a$ from Eq. (ii) in Eq. (i)

$$225 = u^2 + 20(15 - u)$$

i.e., $u^2 - 20u + 75 = 0$
 $(u - 15)(u - 5) = 0$

$\therefore u = 5 \text{ m/s}$
 (15 m/s being not possible)

(b) Using Eq. (ii)
 $a = \frac{5}{3} \text{ m/s}^2$

(c) $u^2 = 0^2 + 2ax$
i.e., $x = \frac{u^2}{2a} = \frac{(5)^2}{2 \times \frac{5}{3}}$

$= 7.5 \text{ m}$

(d) $s = \frac{1}{2} at^2$
 $= \frac{1}{2} \times \frac{5}{3} \times t^2$
 $= \frac{5}{6} t^2$... (iii)

<i>t</i> (s)	0	1	3	6	9	12
<i>v</i> (m/s)	0	5/6	7.5	30	67.5	120

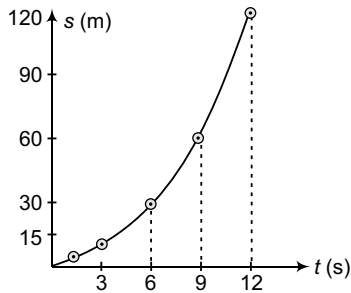

Differentiating Eq. (iii) w.r.t. time *t*

$v = \frac{5}{3} t$

<i>t</i> (s)	0	3	6	9	12
<i>v</i> (m/s)	0	5	10	15	20

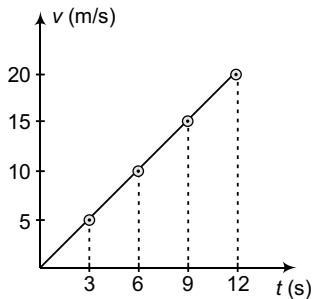

14.

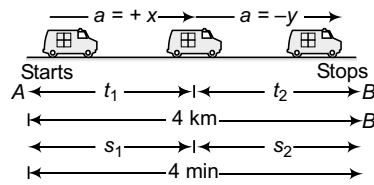

Journey A to P

$v_{\text{max}} = 0 + xt_1$... (i)

and $v_{\text{max}}^2 = 2xs_1$... (ii)

$\Rightarrow t_1 = \frac{v_{\text{max}}}{x}$

Journey P to B

$0 = v_{\text{max}} + (-y)t_2$... (iii)

and $v_{\text{max}}^2 = 2ys_2$... (iv)

$\Rightarrow t_2 = \frac{v_{\text{max}}}{y}$

$\therefore \frac{v_{\text{max}}}{x} + \frac{v_{\text{max}}}{y} = t_1 + t_2 = 4$

or $v_{\text{max}} \left[\frac{1}{x} + \frac{1}{y} \right] = 4$... (v)

From Eq. (ii) and Eq. (iv)

$s_1 + s_2 = \frac{v_{\text{max}}^2}{2x} + \frac{v_{\text{max}}^2}{2y}$

or $4 = \frac{v_{\text{max}}^2}{2} \left[\frac{1}{x} + \frac{1}{y} \right]$... (vi)

Dividing Eq. (vi) by Eq. (v)

$v_{\text{max}} = 2$

Substituting the value of v_{max} in Eq. (v)

$\frac{1}{x} + \frac{1}{y} = 2$ (Proved)

15. Let acceleration of the particle be *a* using

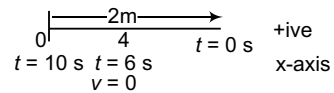

$v = u + at$

$0 = u + a6$

$\therefore a = -\frac{u}{6}$

(a) At $t = 10 \text{ s}$, $s = -2 \text{ m}$

$-2 = u \times 10 + \frac{1}{2} a \times 10^2$

or $-2 = (-6a)10 + 50a$

or $-10a = -2$

or $a = 0.2 \text{ m/s}^2$

24 | Mechanics-1

$$\begin{aligned}
 \text{(b) } v(\text{at } t = 10 \text{ s}) &= u + a t \\
 &= -6a + 10a \\
 &= 4a \\
 &= 0.8 \text{ m/s}
 \end{aligned}$$

(c) Two or three dimensional motion

16.
$$\vec{a} = \frac{\vec{F}}{m} = \frac{10 \text{ N north}}{2 \text{ kg}}$$

$$= 5 \text{ m/s}^2, \text{ north}$$

$$= 5 \hat{j} \text{ m/s}^2$$

$$\vec{u} = 10 \text{ m/s, east}$$

$$= 10 \hat{i} \text{ m/s}$$

using $\vec{v} = \vec{u} + \vec{a} t$

$$\vec{v} = 10 \hat{i} + (5 \hat{j} \times 2)$$

$$= 10 \hat{i} + 10 \hat{j}$$

$$|\vec{v}| = 10\sqrt{2} \text{ m/s}$$

$$\vec{v} = 10\sqrt{2}, \text{ north-east}$$

using $\vec{s} = \vec{u} t + \frac{1}{2} \vec{a} t^2$

$$= (10 \hat{i} \times 2) + \frac{1}{2} (5 \hat{j}) 2^2$$

$$= (20 \hat{i} + 10 \hat{j}) \text{ m}$$

$$|\vec{s}| = \sqrt{20^2 + 10^2}$$

$$= 10\sqrt{5} \text{ m}$$

$$\cot \theta = \frac{20}{10} = 2$$

$$\theta = \cot^{-1} 2$$

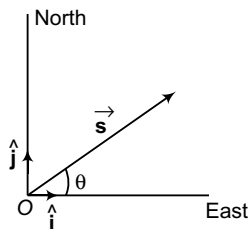

$$\vec{s} = 10\sqrt{5} \text{ m at } \cot^{-1}(2) \text{ from east to north.}$$

17.
$$\vec{s}_0 = (2 \hat{i} + 4 \hat{j}) \text{ m}$$

$$\vec{a}_1 = 2 \hat{i} \text{ m/s}^2 \text{ (} t = 0 \text{ s to } t = 2 \text{ s)} t_1 = 2 \text{ s}$$

$$\vec{u} = \vec{0} \text{ m/s}$$

$$\vec{a}_2 = -4 \hat{j} \text{ m/s}^2 \text{ (} t = 2 \text{ s to } t = 4 \text{ s)} t_2 = 2 \text{ s}$$

(a) Velocity

$$\vec{v}_1 = \vec{u} + \vec{a}_1 t_1$$

$$= \vec{0} + (2 \hat{i}) 2$$

$$= 4 \hat{i}$$

$$\vec{v}_2 = \vec{v}_1 + (\vec{a}_1 + \vec{a}_2) t_2$$

$$= 4 \hat{i} + (2 \hat{i} - 4 \hat{j}) 2$$

or
$$\vec{v}_2 = (8 \hat{i} - 8 \hat{j}) \text{ m/s}$$

(b) Co-ordinate of particle

$$\vec{s}_1 = \vec{s}_0 + \vec{u} t_1 + \frac{1}{2} \vec{a}_1 t_1^2$$

$$= (2 \hat{i} + 4 \hat{j}) + (0)(2) + \frac{1}{2} (2 \hat{i}) 2^2$$

$$= 2 \hat{i} + 4 \hat{j} + 4 \hat{i}$$

$$= 6 \hat{i} + 4 \hat{j}$$

$$\vec{s}_2 = \vec{s}_1 + \vec{v}_1 t_2 + \frac{1}{2} (a_1 + a_2) t_2^2$$

$$= 6 \hat{i} + 4 \hat{j} + (4 \hat{i}) 2 + \frac{1}{2} (2 \hat{i} - 4 \hat{j}) 2^2$$

$$= 6 \hat{i} + 4 \hat{j} + 8 \hat{i} + 4 \hat{i} - 8 \hat{j}$$

$$= 18 \hat{i} - 4 \hat{j}$$

Co-ordinate of the particle

$$[18 \text{ m, } -4 \text{ m}]$$

18.
$$\vec{u} = (2 \hat{i} - 4 \hat{j}) \text{ m/s, } \vec{s}_0 = \vec{0} \text{ m}$$

$$\vec{a} = (4 \hat{i} + \hat{j}) \text{ m/s}^2$$

(a) Velocity

$$\vec{v} = \vec{u} + \vec{a} t$$

$$= (2 \hat{i} - 4 \hat{j}) + (4 \hat{i} + \hat{j}) 2$$

$$= (10 \hat{i} - 2 \hat{j}) \text{ m/s}$$

(b) Co-ordinates of the particle

$$\vec{s} = \vec{s}_0 + \vec{u} t + \frac{1}{2} \vec{a} t^2$$

$$= \vec{0} + (2 \hat{i} - 4 \hat{j}) + \frac{1}{2} (4 \hat{i} + \hat{j}) 2^2$$

$$= 10\hat{i} - 2\hat{j}$$

∴ Co-ordinates of particle would be
[10 m, -2 m]

19. $\vec{u} = 8\hat{j}$ m/s

$$\vec{a} = (4\hat{i} + 2\hat{j}) \text{ m/s}^2$$

$$\vec{s}_0 = \vec{0}$$

$$\vec{s} = 29\hat{i} + n\hat{j}$$

(a) $\vec{s} = \vec{s}_0 + \vec{u}t + \frac{1}{2}\vec{a}t^2$

$$29\hat{i} + n\hat{j} = \vec{0} + (8\hat{j})t + \frac{1}{2}(4\hat{i} + 2\hat{j})t^2$$

$$29\hat{i} + n\hat{j} = 8\hat{j}t + 2\hat{i}t^2 + \hat{j}t^2$$

Comparing the coefficients of \hat{i} and \hat{j}

$$29 = 2t^2 \quad \dots(i)$$

and $n = 8t + t^2 \quad \dots(ii)$

$$\Rightarrow t = \sqrt{\frac{29}{2}} = 3.807 \text{ s}$$

Substituting value of t in Eq. (ii)

$$n = 8 \times 3.807 + (3.807)^2$$

$$= 44.95$$

(b) Speed at $t = \sqrt{\frac{29}{2}}$ s

$$\vec{v} = \vec{u} + \vec{a}t$$

$$= 8\hat{j} + (4\hat{i} + 2\hat{j})(3.807)$$

$$= (2 \times 3.807)\hat{i} + \{(4 \times 3.807) + 8\}\hat{j}$$

$$= (7.614\hat{i} + 23.228\hat{j}) \text{ m/s}$$

$$\text{speed} = |\vec{v}| = \sqrt{(7.614)^2 + (23.228)^2}$$

$$= 24.44 \text{ m/s}$$

20. $\vec{s}_0 = 5\hat{i}$ m

at $t = 0.02$ s, $\vec{s} = (5.1\hat{i} + 0.4\hat{j})$ m

$$\text{Average velocity } \vec{v}_{\text{av}} = \frac{\vec{s} - \vec{s}_0}{0.02}$$

$$= \frac{(5.1\hat{i} + 0.4\hat{j}) - (5\hat{i})}{0.02}$$

$$= \frac{0.1\hat{i} + 0.4\hat{j}}{0.02}$$

$$= 5\hat{i} + 20\hat{j} \text{ m/s}$$

$$|\vec{a}_{\text{av}}| = \sqrt{5^2 + 20^2}$$

$$= 20.6 \text{ m/s}$$

$$\tan \theta = \frac{20}{5}$$

i.e., $\theta = \tan^{-1}(4)$

Non uniform acceleration.

21. $x = 2 + t^2 + 2t^3$

(a) At $t = 0$, $x = 2$ m

(b) $\frac{dx}{dt} = 2t + 6t^2$

$$\left(\frac{dx}{dt}\right)_{t=0} = 0 \text{ m/s}$$

(c) $\frac{d^2x}{dt^2} = 2 + 12t$

(a) $_{t=2\text{s}} = 2 + (12 \times 2) = 26 \text{ m/s}^2$

22. $a = -v \frac{dv}{dx}$

$$= -(10) \times 3$$

$$= -30 \text{ m/s}^2$$

23. $s = t^3 - 9t^2 - 15t$

$$\therefore v = \frac{ds}{dt} = 3t^2 - 18t - 15$$

ie, $a = \frac{dv}{dt} = 6t - 18$

Acceleration (a) in the interval $0 \leq t \leq 10$ s

will be maximum at $t = 10$ s

$$a(\text{at } t = 10 \text{ s}) = (6 \times 10) - 18$$

$$= 42 \text{ m/s}^2$$

24. $a = 3 - 2t$

$$\frac{dv}{dt} = 3 - 2t$$

or $\int dv = \int (3 - 2t) dt$

or $v = 3t - t^2 + c$

or $v = 3t - t^2 + v_0$ [as at $t = 0$, $v = v_0$]

or $\int ds = \int (3t - t^2 + v_0) dt$

or $s = \frac{3t^2}{2} - \frac{t^3}{3} + v_0t$

26 | Mechanics-1

(a) Displacement at $t = 0$ s = Displacement at $t = 5$ s

$$0 = \frac{3 \cdot 5^2}{2} - \frac{5^3}{3} + v_0 \cdot 5$$

$$\Rightarrow v_0 = 5/6 = 0.8333 \text{ s}$$

$$(b) v = 3t - t^2 + v_0$$

Velocity at $t (= 5.00 \text{ s})$

$$\begin{aligned} &= 3 \cdot 5 - 5^2 + 0.833 \\ &= 15 - 25 + 0.833 \\ &= -9.167 \text{ m/s} \end{aligned}$$

25. $v = 3t^2 - 6t$

$$\therefore \int ds = \int (3t^2 - 6t) dt$$

$$\text{or } s = t^3 - 3t^2 + c$$

$$\text{or } s = t^3 - 3t^2 = t^2(t - 3)$$

$$(a) \text{ Average velocity} = \frac{(3.5)^2(3.5 - 3)}{3.5}$$

$$\begin{aligned} &= 3.5 \times 0.5 \\ &= 1.75 \text{ m/s} \end{aligned}$$

(b) Distance covered

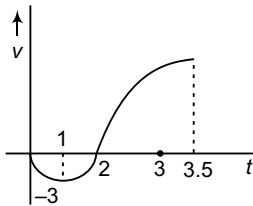

$$= \int_0^2 (6t - 3t^2) dt + \int_2^{3.5} (3t^2 - 6t) dt$$

$$= [3t^2 - t^3]_0^2 + [t^3 - 3t^2]_2^{3.5}$$

$$= 3(2)^2 - (2)^3 + (3.5)^3 - 3(3.5)^2 - (2)^3 + 3(2)^2$$

$$= 12 - 8 + 42.875 - 36.75 - 8 + 12$$

$$= 14.125 \text{ m}$$

$$(c) \text{ Average speed} = \frac{14.125}{3.5}$$

$$= 4.036 \text{ m/s}$$

26. $v = \frac{4}{a}$

$$\text{i.e., } va = 4 \quad \dots(i)$$

$$\text{or } \int v dv = \int 4 dt$$

$$\text{or } \frac{v^2}{2} = 4t + C$$

Now, at $t = 2$ s, $v = 6$ m/s

$$\therefore \frac{6^2}{2} = (4 \times 2) + C$$

Thus, $C = 10$.

$$\text{i.e., } \frac{v^2}{2} = 4t + 10 \quad \dots(ii)$$

\therefore at $t = 3$ s,

$$\frac{v^2}{2} = (4 \times 3) + 10$$

$$v^2 = 44$$

$$v = \sqrt{44} = 2\sqrt{11} \text{ m/s}$$

Substituting above found value of v in Eq. (i),

$$2\sqrt{11} a = 4$$

$$\text{i.e., } a = \frac{2}{\sqrt{11}}$$

$$= 0.603 \text{ m/s}^2$$

27. According to question, the velocity of the particle varies as shown in figure.

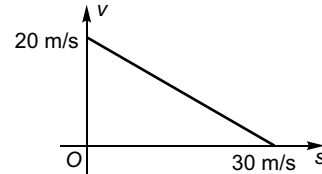

$$\therefore \frac{v}{20} + \frac{s}{30} = 1$$

$$\text{or } 3v + 2s = 60$$

$$\text{or } 3v = 60 - 2s \quad \dots(i)$$

Differentiating above equation w.r.t. time t

$$3 \cdot \frac{dv}{dt} = -2 \cdot \frac{ds}{dt}$$

$$\text{or } 3a = -2v$$

$$\text{or } 3a = -2 \cdot \left(\frac{60 - 2s}{3} \right) \quad [\text{using Eq. (i)}]$$

$$\text{or } a = -\frac{2}{9}(60 - 2s)$$

$$= -\frac{2}{9}(60 - 2 \times 15) \quad [\text{at } s = 15 \text{ m}]$$

$$= -\frac{20}{3} \text{ m/s}^2$$

$$\begin{aligned}
 S_1 &= \frac{1}{2}gt^2 \\
 &= \frac{1}{2}g\frac{h}{g} \\
 &= \frac{h}{2}
 \end{aligned}$$

∴ Assertion is true.

Reason is also true as assertion is based on this.

Objective Questions (Level 2)

Single Correct Option

1. Applying sine formula in ΔAOB

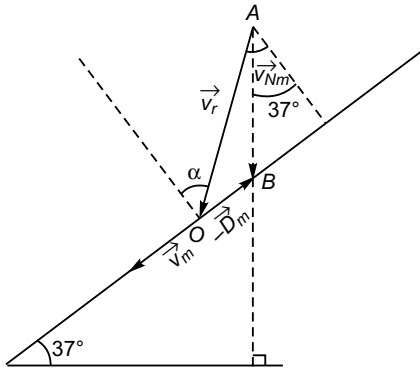

$$\begin{aligned}
 \frac{AO}{\sin(96^\circ + 37^\circ)} &= \frac{OB}{\sin(\alpha - 37^\circ)} \\
 \frac{v_r}{\cos 37^\circ} &= \frac{v_m}{\sin(\alpha - 37^\circ)} \quad \dots(i)
 \end{aligned}$$

Applying sine formula in

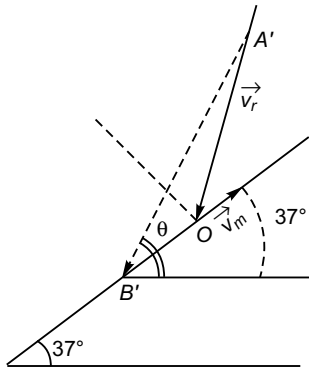

$$\begin{aligned}
 \Delta AOB' \\
 \frac{AO}{\sin(\theta - 37^\circ)} &= \frac{OB'}{\sin[(\alpha + \theta)]} \\
 \frac{v_r}{\sin(\theta - 37^\circ)} &= \frac{v_m}{\sin[127^\circ - (\alpha + \theta)]} \quad \dots(ii)
 \end{aligned}$$

12. Please see answer to question no. 2 of objective questions (level 1).

$$T_2 = \frac{um}{\sqrt{(mg + f)(mg - f)}}$$

Now, if masses of the bodies are different, the value of T_2 (time to reach earth) will be different if f (air resistance) is same.

Thus, Assertion is false further Reason is correct as explained above.

$$\begin{aligned}
 \angle B'AO &= 180^\circ - (90^\circ + \alpha) - (\theta - 37^\circ) \\
 &= 90^\circ - \alpha - \theta + 37^\circ \\
 &= 127^\circ - (\alpha + \theta)
 \end{aligned}$$

Comparing Eqs. (i) and (ii)

$$\begin{aligned}
 \frac{\sin(\alpha - 37^\circ)}{\cos 37^\circ} &= \frac{\sin[127^\circ - (\alpha + \theta)]}{\sin(\theta - 37^\circ)} \\
 \frac{\sin \alpha \cos 37^\circ - \cos \alpha \sin 37^\circ}{\cos 37^\circ} &= \frac{\sin 127^\circ \cos(\alpha + \theta) + \cos 127^\circ \sin(\alpha + \theta)}{\sin \theta \cos 37^\circ - \cos \theta \sin 37^\circ}
 \end{aligned}$$

$$\begin{aligned}
 \sin \alpha - \cos \alpha \tan 37^\circ &= \frac{\frac{4}{5} \cos(\alpha + \theta) + \frac{3}{5} \sin(\alpha + \theta)}{\frac{4}{5} \sin \theta - \frac{3}{5} \cos \theta} \\
 \text{or } \sin \alpha - \frac{3}{4} \cos \alpha &= \frac{4 \cos(\alpha + \theta) + 3 \sin(\alpha + \theta)}{4 \sin \theta - 3 \cos \theta} \\
 \text{or } \sin \alpha - \frac{3}{4} \cos \alpha &= \frac{4[\cos \alpha \cos \theta - \sin \alpha \sin \theta] + 3[\sin \alpha \cos \theta + \cos \alpha \sin \theta]}{4 \sin \theta - 3 \cos \theta} \\
 \text{or } \sin \alpha - \frac{3}{4} \cos \alpha &= \frac{4[\cos \alpha - \sin \alpha \tan \theta] + 3[\sin \alpha + \cos \alpha \tan \theta]}{4 \tan \theta - 3} \\
 \text{or } \sin \alpha - \frac{3}{4} \cos \alpha &= \frac{4[\cos \alpha - \frac{7}{8} \sin \alpha] + 3[\sin \alpha + \frac{7}{8} \cos \alpha]}{4 \cdot \frac{7}{8} - 3} \\
 \text{or } \sin \alpha - \frac{3}{4} \cos \alpha &= \frac{4[8 \cos \alpha - 7 \sin \alpha] + 3[8 \sin \alpha + 7 \cos \alpha]}{4}
 \end{aligned}$$

40 | Mechanics-1

or $4 \sin \alpha - 3 \cos \alpha$
 $= 32 \cos \alpha - 28 \sin \alpha + 24 \sin \alpha + 21 \cos \alpha$

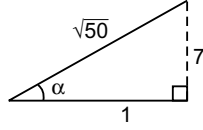

or $32 \cos \alpha + 21 \cos \alpha + 3 \cos \alpha$
 $= 28 \sin \alpha - 24 \sin \alpha + 4 \sin \alpha$

or $56 \cos \alpha = 8 \sin \alpha$
 $\tan \alpha = \frac{7}{1}$

From Eq. (i)

$$\frac{v_r}{\cos 37^\circ} = \frac{v_m}{\sin(\alpha - 37^\circ)}$$

$$\therefore v_r = \frac{v_m \cos 37^\circ}{\sin \alpha \cos 37^\circ - \cos \alpha \sin 37^\circ}$$

$$= \frac{v_m \cos 37^\circ}{\cos \alpha \cos 37^\circ [\tan \alpha - \tan 37^\circ]}$$

$$= \frac{v_m}{\cos \alpha \left[7 - \frac{3}{4} \right]}$$

$$= \frac{4}{25} \cdot \frac{v_m}{\cos \alpha}$$

$$= \frac{4}{25} \times \frac{5}{1} \times \sqrt{50}$$

$$= \sqrt{32}$$

Option (b) is correct.

2. $\frac{dv}{dt} = -4v + 8$
 $a = -4v + 8$

At the time the body acquires terminal speed its acceleration (a) must be zero.

Thus

$$-4v + 8 = 0$$

$$v = 2 \text{ m/s}$$

Terminal speed = 2 m/s.

Option (b) is correct.

3. Particles will collide if

$$\frac{\vec{v}_1 - \vec{v}_2}{|\vec{v}_1 - \vec{v}_2|} = \frac{\vec{r}_2 - \vec{r}_1}{|\vec{r}_2 - \vec{r}_1|}$$

$$\vec{v}_1 - \vec{v}_2 = (5\hat{i} + 10\hat{j} + 5\hat{k}) - (10\hat{i} + 5\hat{j} + 5\hat{k})$$

$$= -5\hat{i} + 5\hat{j}$$

$$|\vec{v}_1 - \vec{v}_2| = 5\sqrt{2}$$

$$\therefore \frac{\vec{v}_1 - \vec{v}_2}{|\vec{v}_1 - \vec{v}_2|} = -\frac{1}{\sqrt{2}}\hat{i} + \frac{1}{\sqrt{2}}\hat{j}$$

$$\vec{r}_2 - \vec{r}_1 = \vec{r}_2 = 30\hat{i}$$

$$|\vec{r}_2 - \vec{r}_1| = 30$$

$$\therefore \frac{\vec{r}_2 - \vec{r}_1}{|\vec{r}_2 - \vec{r}_1|} = \hat{i} \neq \frac{\vec{v}_1 - \vec{v}_2}{|\vec{v}_1 - \vec{v}_2|}$$

\therefore Option (c) is correct.

4. Displacement along y -axis at time t

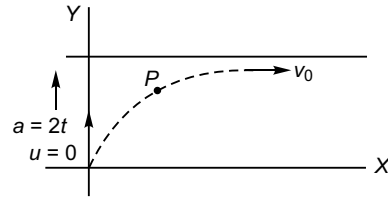

$$a = 2t$$

$$\frac{dv_y}{dt} = 2t$$

or $\int dv_y = \int 2t dt$

or $v_y = t^2 + C_1$

At $t = 0, v_y = 0$ (given)

$$\therefore C_1 = 0$$

$$\therefore v_y = t^2$$

$$\Rightarrow \frac{dy}{dt} = t^2$$

or $\int dy = \int t^2 + C_2$

or $y = \frac{t^3}{2} + C_2$

At $t = 0, Y = 0$ (given)

$$\therefore Y = \frac{t^3}{3} \quad \dots(i)$$

Displacement along x -axis at time t :

$$x = v_0 t$$

or $t = \frac{x}{v_0}$

Substituting above value of t in Eq. (i)

$$Y = \frac{1}{3} \left(\frac{x}{v_0} \right)^3$$

Option (a) is correct.

5. $t = \alpha x^2 + \beta x$

Differentiating w.r.t. time t

$$1 = \alpha \cdot 2x \frac{dx}{dt} + \beta \cdot \frac{dx}{dt}$$

or

$$v(\beta + 2\alpha \cdot x) = 1$$

or

$$v = (\beta + 2\alpha \cdot x)^{-1}$$

∴

$$\frac{dv}{dt} = -\frac{1}{(\beta + 2\alpha x)^2} \cdot 2\alpha \cdot \frac{dx}{dt}$$

$$a = -\frac{2\alpha}{(\beta + 2\alpha x)^2} \cdot v$$

$$= -\frac{2\alpha}{(\beta + 2\alpha x)^2} \cdot v$$

$$= -(2\alpha v^2) \cdot v$$

$$= -2\alpha v^3$$

∴ Retardation = $2\alpha v^3$

Option (a) is correct.

6. $f = a - bx$

$$\therefore v \frac{dv}{dx} = a - bx$$

or

$$\int v dv = \int (a - bx) dx$$

or

$$\frac{v^2}{2} = a \cdot x - \frac{bx^2}{2} + C$$

As at $x = 0$ car is at rest $C = 0$

$$\therefore \frac{v^2}{2} = ax - \frac{bx^2}{2} \quad \dots(i)$$

For v to be maximum,

$$\frac{d}{dx} \left(ax - \frac{bx^2}{2} \right) = 0$$

i.e.,

$$a - bx = 0$$

or

$$x = \frac{a}{b}$$

Substituting $x = \frac{a}{b}$ in Eq. (i),

$$\frac{v_{\max}^2}{2} = a \cdot \frac{a}{b} - \frac{b}{2} \left(\frac{a}{b} \right)^2$$

$$= \frac{a^2}{2b}$$

∴

$$v_{\max} = \frac{a}{\sqrt{b}}$$

Car will come to rest when

$$ax - \frac{bx^2}{2} = 0$$

$$x = \frac{2a}{b}$$

∴ Distance between two stations = $\frac{2a}{b}$

Option (a) is correct.

7. Force = $-kx^2$

$$\therefore \text{Acceleration} = -\frac{k^2}{2^m} x^2$$

$$\Rightarrow v \frac{dv}{dx} = -\frac{kx^2}{m}$$

$$\text{or} \quad \int v dv = \int -\frac{kx^2}{m} dx$$

$$\text{or} \quad \frac{v^2}{2} = -\frac{k}{m} \frac{x^3}{3} + C$$

Now at $x = a, v = 0$

$$\therefore C = \frac{k a^3}{m \cdot 3}$$

$$\text{Thus} \quad \frac{v^2}{2} = -\frac{kx^2}{m \times 3} + \frac{ka^3}{m \times 3}$$

∴ Velocity at $x = 0$

$$v = \sqrt{\frac{2ka^3}{3m}}$$

Option (d) is correct.

8. $v_x = 4 + 4t$ and $v_y = 4t$

$$\therefore \frac{dx}{dt} = 4 + 4t \quad \text{and} \quad \frac{dy}{dt} = 4t$$

$$\text{or} \quad \int dx = \int (4 + 4t) dt$$

$$\text{and} \quad \int dy = \int 4t dt$$

$$\text{or} \quad x = 4t + 2t^2 + C_1$$

$$\therefore C_1 = 1$$

$$\text{Thus} \quad x = 4t + 2t^2 + 1 \quad \dots(i)$$

$$\text{and} \quad y = 2t^2 + C_2$$

$$\text{At} \quad t = 0 \quad x = 1$$

and at $t = 0, y = 2$

$$\therefore C_2 = 0$$

$$\text{Thus} \quad y = 2t^2 + 2 \quad \dots(ii)$$

Substituting value of t in Eq. (i) in terms of y using Eq. (ii) we won't get relationship as mentioned in option (a), (b) or (c).

∴ Option (d) is correct.

$$9. \quad a = \frac{1}{2} gt^2$$

$$= 4 \times \tan 120^\circ$$

$$= 4 \times [-\tan 60^\circ]$$

$$= -4\sqrt{3} \text{ m/s}^2$$

∴ Magnitude of acceleration = $4\sqrt{3} \text{ ms}^{-2}$.

Option (a) is correct.

42 | Mechanics-1

10. $x_1 = \frac{1}{2}gt^2$
 $x_1 + x_2 = \frac{1}{2}g(2t)^2$
 $\therefore x_2 = \frac{1}{2}g \cdot 4t^2 - \frac{1}{2}gt^2$
 $x_2 = \frac{3}{2}gt^2$
 $x_2 - x_1 = gt^2$
 $\Rightarrow t = \sqrt{\frac{x_2 - x_1}{g}}$

Option (a) is correct.

11. $y^2 + x^2 = l^2$
 $\therefore 2y \cdot \frac{dy}{dt} + 2x \cdot \frac{dx}{dt} = 0$
 or $\frac{dy}{dt} = -\frac{x}{y} \frac{dx}{dt}$
 $= -\frac{x}{x \tan 30^\circ} \frac{dx}{dt}$
 $= -2\sqrt{3} \text{ m/s}$

Option (c) is correct.

12. Maximum separation (x_{\max}) between the police and the thief will be at time t (shown in figure)

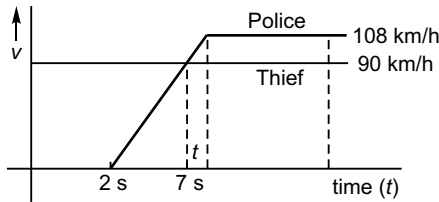

$$t - 2 = \frac{v}{a} = \frac{90 \text{ kmh}^{-1}}{5 \text{ ms}^{-2}}$$

$$= \frac{90}{5} \times \frac{1000}{3600} \text{ s}$$

i.e., $t = 7 \text{ s}$

$$x_{\max} = [90 \text{ kmh}^{-1} \times 7 \text{ s}] - \frac{1}{2} \times 5 \times 90 \text{ kmh}^{-1}$$

$$= \frac{90 \times 1000}{3600} \times \frac{9}{2} \text{ m}$$

$$= 112.5 \text{ m}$$

Option (a) is correct.

13. If meeting time is t

$$\frac{2v}{3} \sin \theta = u \sin 30^\circ$$

i.e., $\sin \theta = \frac{3}{4}$

or $\theta = \sin^{-1} \frac{3}{4}$

Option (c) is correct.

14. Distance = $\frac{1}{2} \left(\frac{\alpha\beta}{\alpha + \beta} \right) t^2$
 $\therefore 0 = \frac{1}{2} \left(\frac{1 \times 4}{1 + 4} \right) t^2$
 $\Rightarrow t = \sqrt{500} \text{ s}$
 $= 22.36 \text{ s}$

Option (a) is correct.

15. Let $BC = t'$

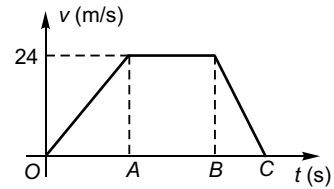

$$\therefore \frac{24}{t'} = 4$$

$$\Rightarrow t' = 6 \text{ s}$$

$$\therefore OB = 50 \text{ s}$$

Let $OA = t$

$$\therefore AB = 56 - t$$

$$1032 = \frac{1}{2} [56 + (56 - t)] \times 24$$

$$\Rightarrow t = 20 \text{ s}$$

$$\therefore \text{maximum acceleration} = \frac{24 \text{ m/s}}{20 \text{ s}}$$

$$= 1.2 \text{ m/s}^2$$

Option (b) is correct.

16. From $\triangle OAB$

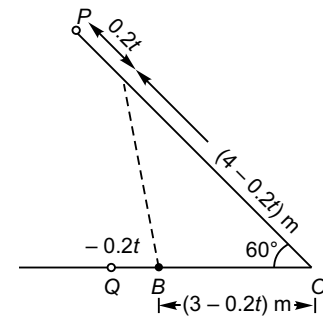

$$\cos AOB = \frac{OA^2 + OB^2 - AB^2}{2 \cdot OA \cdot OB}$$

$$\begin{aligned} \therefore OA^2 + OB^2 - AB^2 &= OA \cdot OB \\ \text{i.e., } AB^2 &= OA^2 + OB^2 - OA \cdot OB \\ &= (4 - 0.2t)^2 + (3 - 0.2t)^2 \\ &\quad + (4 - 0.2t)(3 - 0.2t) \\ \text{or } AB^2 &= 16 + 0.04t^2 - 1.6t + 9 + 0.04t^2 \\ &\quad - 1.2t + 12 - 1.4t + 0.04t^2 \\ \text{or } AB^2 &= 0.12t^2 - 4.2t + 37 \end{aligned}$$

For AB to be minimum

$$0.24t - 4.2 = 0$$

$$\text{or } t = 17.5 \text{ s}$$

$$\begin{aligned} \therefore (AB)_{\min}^2 &= 0.12(17.5)^2 - 4.2 \times (17.5) + 37 \\ &= 36.75 - 73.5 + 37 \end{aligned}$$

$$\begin{aligned} (AB)_{\min}^2 &= 0.75 \text{ m}^2 \\ &= 7500 \text{ cm}^2 \\ &= 50\sqrt{3} \text{ cm} \end{aligned}$$

Option (d) is correct.

17. Velocity of ball w.r.t. elevator = 15 m/s

Acceleration of ball w.r.t. elevator

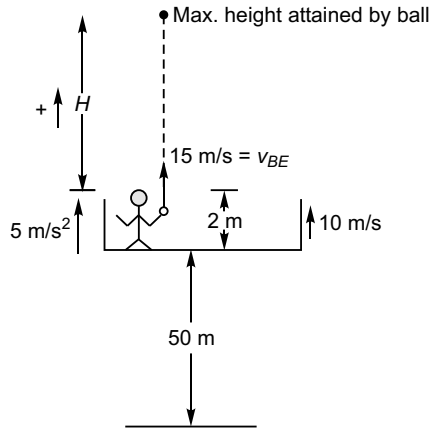

$$= (-10) - (+5) = -15 \text{ m/s}^2$$

Final displacement of ball w.r.t. elevator = -2 m

$$\therefore -2 = 15t + \frac{1}{2}(-15)t^2$$

$$\text{i.e., } 15t^2 - 30t - 4 = 0$$

$$\begin{aligned} \therefore t &= \frac{30 + \sqrt{900 + 4 \times 4 \times 15}}{2 \times 15} \\ &= 2.13 \text{ s} \end{aligned}$$

Option (a) is correct.

18. Velocity of ball w.r.t. ground (v_{BE})

$$\begin{aligned} &= (15 + 10) \text{ m/s} \\ &= 25 \text{ m/s} \end{aligned}$$

$$\text{Now } v^2 = u^2 + 2as$$

$$\therefore 0^2 = (25)^2 + 2(-10)H$$

$$\text{or } H = 31.25 \text{ m}$$

Maximum height by ball as measured from ground = 31.25 + 2 + 50

$$= 83.25 \text{ m}$$

Option (c) is correct.

19. Displacement of ball w.r.t. ground during its flight = $H = 31.25 \text{ m}$

Option (d) is correct.

20. Displacement of ball w.r.t. floor of elevator at time t

$$s = 15t + \frac{1}{2}(-15)t^2 + 2$$

s will be maximum, when

$$\frac{ds}{dt} = 0$$

$$\text{i.e., } 15 - 15t = 0$$

$$\text{i.e., } t = 1 \text{ s}$$

$$\begin{aligned} \therefore s_{\max} &= (15 \times 1) + \frac{1}{2}(-10)(1)^2 + 2 \\ &= 12 \text{ m} \end{aligned}$$

Option (a) is correct.

21. Let the particles meet at time t

i.e., displacement of the particles are equal and which is possible when

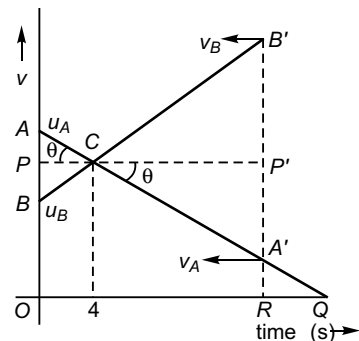

$$\text{Area of } \triangle ACB = \text{Area of } \triangle A'B'C$$

[Area $OBCA' \theta O$ being common]

$$\text{or } \text{Area of } \triangle APC = \text{Area } A'P'C$$

$$\frac{1}{2} AP \times PC = \frac{1}{2} A'P' \times P'C$$

$$\text{or } AP \times PC = A'P' \times P'C$$

$$\text{or } (PC \tan \theta) PC = (P'C \tan \theta) P'C$$

$$\text{or } PC = P'C'$$

44 | Mechanics-1

$\therefore OR = PC + P' C' = 2PC = 8 \text{ s.}$

Option (c) is correct.

22. Area of $\Delta A' B' O = \text{Area of } \Delta ABO$

$\therefore \frac{1}{2}(v_B - v_A) \cdot 4 = \frac{1}{2}(u_A - u_B) \cdot 4$

i.e., $v_B - v_A = u_A - u_B$
 $= 5 - 15 = -10$

$\Rightarrow v_A - v_B = 10 \text{ ms}^{-1}$

Option (b) is correct.

More than One Correct Options

1. $\therefore a = -\alpha v^{1/2}$... (i)

i.e., $\frac{dv}{dt} = -\alpha v^{1/2}$

or $\int v^{-1/2} dv = -\alpha \int dt$
 $2v^{1/2} = -\alpha t + C_1$

Now, at $t = 0, v = v_0$

$\therefore C_1 = 2v_0^{1/2}$

$\Rightarrow 2v^{1/2} = -\alpha t + 2v_0^{1/2}$

i.e., the particle will stop at

$t = \frac{2v_0^{1/2}}{\alpha}$

Option (a) is correct.

Option (b) is incorrect.

From Eq. (i),

$v \frac{dv}{dt} = -\alpha v^{1/2}$

or $\int v^{1/2} dv = -\alpha \int dx$

or $\frac{2}{3} v^{3/2} = -\alpha x + C_2$

As at $x = 0, v = v_0, C_2 = \frac{2}{3} v_0^{3/2}$

$\therefore \frac{2}{3} v^{3/2} = -\alpha x + \frac{2}{3} v_0^{3/2}$

i.e., when the particle stops

$x = \frac{2}{3\alpha} v_0^{3/2}$

Option (d) is correct.

Option (c) is incorrect.

2. $a = -0.5 t \text{ (m/s}^2\text{)}$

$\frac{dv}{dt} = -\frac{t}{2}$

or $\int dv = -\frac{1}{2} \int t dt$

23. $u_A = 6 \text{ ms}^{-1}, u_B = 12 \text{ ms}^{-1}$

and at $t = 4 \text{ s}$ common velocity = 8 ms^{-1}

To find velocity of A at $t = 10 \text{ s}$

$\frac{v_A - 8}{10 - 4} = \frac{u_A - 8}{4}$

or $\frac{v_A - 8}{6} = \frac{6 - 8}{4}$

$\therefore v_A = 5 \text{ ms}^{-1}$

Option (d) is correct.

$v = -\frac{t^2}{4} + C_1$

At $t = 0, v = 16 \text{ m/s}$

$\therefore v = -\frac{t^2}{4} + 16$... (i)

From above relation v is zero at

$t = 8 \text{ s}$

Options (a) is correct.

From relation (i),

$\frac{ds}{dt} = -\frac{t^2}{4} + 16$

$\therefore \int ds = \int \left(-\frac{t^2}{4} + 16 \right) dt$

i.e., $s = -\frac{t^3}{12} + 16t + C_2$

$s = -\frac{t^3}{12} + 16t$ [As at $t = 0, s = 0$]

At $t = 4 \text{ s}$

$s = 58.67 \text{ m}$

Option (b) is correct.

The particle returns back at $t = 8 \text{ s}$

From relation (ii)

$s_8 = -\frac{8^3}{12} + (16 \times 8) = 85.33 \text{ m}$

$s_{10} = -\frac{10^3}{12} + (16 \times 10) = 76.66 \text{ m}$

Distance travelled in 10 s

$= s_8 + (s_8 - s_{10})$
 $= (2 \times 85.33) - 76.66$
 $= 94 \text{ m}$

Option (c) is correct.

Velocity of particle at $t = 10 \text{ s}$

$$\begin{aligned}
 u_{10} &= -\frac{(10)^2}{4} + 16 \\
 &= -25 + 16 \\
 &= -9 \text{ m/s}
 \end{aligned}$$

∴ Speed of particle at $t = 10$ s is 9 m/s.

Option (d) is correct.

3. $|\vec{v}|$ is scalar.

∴ Option (a) is incorrect.

$$\frac{d\vec{v}}{dt} = \vec{a} \quad (\text{by definition}).$$

∴ Option (b) is correct.

v^2 is scalar.

∴ Option (c) is incorrect.

$$\frac{\vec{v}}{|\vec{v}|} \text{ is } \hat{v} \text{ (unit vector)}$$

$$\therefore \frac{d\hat{v}}{dt} = \hat{a} \neq \vec{a}$$

∴ Option (d) is incorrect.

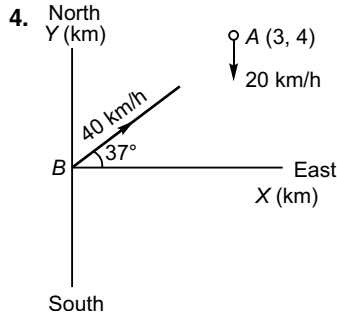

$$\vec{v}_A = -20 \hat{j} \text{ kmh}^{-1}$$

$$\begin{aligned}
 \vec{v}_B &= (40 \cos 37^\circ) \hat{i} + (40 \sin 37^\circ) \hat{j} \text{ kmh}^{-1} \\
 &= (32 \hat{i} + 24 \hat{j}) \text{ kmh}^{-1}
 \end{aligned}$$

$$\begin{aligned}
 \vec{v}_{AB} &= \vec{v}_A - \vec{v}_B \\
 &= (-20 \hat{j}) - (32 \hat{i} + 24 \hat{j}) \\
 &= -32 \hat{i} - 44 \hat{j}
 \end{aligned}$$

Option (a) is correct.

Option (c) is incorrect.

At any time

$$\begin{aligned}
 \vec{S}_A &= 3 \hat{i} + 4 \hat{j} + (-20 \hat{j})t \\
 \vec{S}_B &= (32 \hat{i} + 24 \hat{j})t
 \end{aligned}$$

Position of A relative to B :

$$\begin{aligned}
 \vec{S}_{AB} &= \vec{S}_A - \vec{S}_B \\
 &= (3 \hat{i} + 4 \hat{j} - 20t \hat{j}) - (32t \hat{i} + 24t \hat{j}) \\
 &= (3 - 32t) \hat{i} + (4 - 44t) \hat{j}
 \end{aligned}$$

Option (b) is correct.

Option (d) is incorrect.

5. Case I.

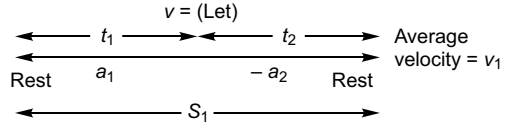

$$\begin{aligned}
 v &= a_1 t_1 \\
 v &= a_2 t_2 \\
 s_1 &= \frac{1}{2} a_1 t_1^2 + \frac{1}{2} a_2 t_2^2
 \end{aligned}$$

Case II.

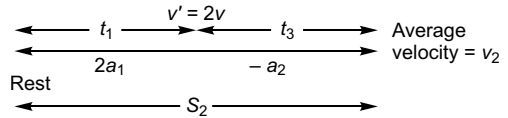

$$\begin{aligned}
 v' &= 2a_1 t_1 \\
 &= 2v \\
 2v &= a_2 t_3 \\
 2(a_2 t_2) &= a_2 t_3 \\
 \Rightarrow t_3 &= 2t_2 \\
 s_2 &= \frac{1}{2} (2a_1) t_1^2 + \frac{1}{2} a_2 t_3^2 \\
 &= a_1 t_1^2 + \frac{1}{2} a_2 (2t_2)^2 \\
 &= a_1 t_1^2 + 2a_2 t_2^2 \\
 2s_2 &= a_1 t_1^2 + a_2 t_2^2 \\
 \therefore s_1 &> 2s_2 \quad \dots(i) \\
 4s_1 &= 2a_1 t_1^2 + 2a_2 t_2^2 \\
 \therefore s_2 &< 4s_1 \quad \dots(ii)
 \end{aligned}$$

Combining Eqs. (i) and (ii),

$$2s_1 < s_2 < 4s_1$$

Option (d) is correct.

In Case I. $v_{av} = \frac{s_1}{t_1 + t_2}$

$$\begin{aligned}
 \text{i.e., } v_1 &= \frac{\frac{1}{2} a_1 t_1^2 + \frac{1}{2} a_2 t_2^2}{t_1 + t_2}
 \end{aligned}$$

$$= \frac{(a_1 t_1) t_1 + (a_2 t_2) t_2}{2(t_1 + t_2)}$$

$$= \frac{v t_1 + v t_2}{2(t_1 + t_2)} = \frac{v}{2}$$

In Case II.

$$v_{av} = \frac{s_2}{t_1 + t_3}$$

i.e.,

$$v_2 = \frac{a_1 t_1^2 + 2a_2 t_2^2}{t_1 + t_3}$$

$$= \frac{(a_1 t_1) t_1 + a_2 t_2 (2 t_2)}{t_1 + 2 t_2}$$

$$= \frac{v t_1 + v (2 t_2)}{t_1 + 2 t_2}$$

$$= v = 2v_1$$

Option (a) is correct.

Option (b) is incorrect.

6. If the particle's initial velocity is + ive and has some constant - ive acceleration the particle will stop somewhere and then return back to have zero displacement at same time $t (> 0)$.

Also if particle's initial velocity is - ive and has some constant + ive acceleration the particle will stop somewhere and then return back to have zero displacement at same time $t (> 0)$.

∴ Options (b) and (c) are correct.

and options (a) and (d) are incorrect.

7. $F = \alpha t$

$$\Rightarrow ma = \alpha t$$

or $a = \frac{\alpha}{m} t \quad \dots(i)$

∴ Graph between a (acceleration) and time (t) will be as curve 1.

∴ Option (a) is correct.

From equation

$$\frac{dv}{dt} = \frac{\alpha}{m} \cdot t$$

∴ $\int dv = \frac{\alpha}{m} \int t dt$

i.e., $v = \frac{\alpha}{m} \cdot \frac{t^2}{2} + c$

∴ Graph between velocity (v) and time (t) will be as curve 2.

Option (b) is correct.

8. $a = -\frac{6}{30} s + 6$

$$5a = -s + 30$$

$$5 \cdot v \frac{dv}{ds} = -s + 30$$

or $\int 5v dv = \int (-s + 30) ds$

or $\frac{5v^2}{2} = -\frac{s^2}{2} + 30s + c_1$

or $\frac{5}{2} v^2 = -\frac{S^2}{2} + 30s \quad \dots(i)$

[$C_1 = 0$ as at $s = 0$ particle is at rest]

Substituting $s = 10$ m in Eq. (i),

$$\frac{5}{2} v^2 = -\frac{(10)^2}{2} + 300$$

i.e., $v = 10$ m/s

∴ Option (b) is correct.

From Eq. (i) v to be maximum

$$-s + 30 = 0$$

$$s = 30$$

∴ $\frac{5}{2} v_{\max}^2 = -\frac{(30)^2}{2} + (30 \times 30)$

or $\frac{5}{2} v_{\max}^2 = 450$

or $v_{\max} = \sqrt{180}$ m/s

Option (c) is correct.

9. If particle's path is

(i) straight with backward motion

(ii) not straight somewhere.

Distance moved will be greater than the modulus of displacement

∴ $|\vec{v}_{av}| < v_{av}$

Option (a) is correct.

If particle returns to its initial position, the value of \vec{v}_{av} will be zero while its average speed (v_{av}) will not be zero.

∴ Option (c) is correct.

10. If $u = 0, v = at$ and $s = \frac{1}{2} at^2$

∴ $v-t$ graph will be as shown in (a).

$s-t$ graph will be as shown in (d).

11. Swimmer will reach point B

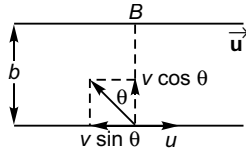

if $v \sin \theta = u$
 i.e., $v > u$

Option (c) is correct.

Time to cross the river

$$t = \frac{b}{v \cos \theta} = \frac{b}{\sqrt{v^2 - u^2}} \quad [\text{as } v \sin \theta = u]$$

Option (b) is correct.

$$t_{\min} = \frac{b}{v(\cos \theta)_{\max}} = \frac{b}{v}$$

Option (a) is correct.

12. At time T , particle's velocity change from -ive to + ive.

Option (a) is correct.

As slope $v-t$ is same throughout, particle's acceleration is constant.

Option (b) is correct.

As net area under the curve is zero.

$$\left[A_{\text{net}} = \left(\frac{vT}{2} \right) + \left(\frac{-vT}{2} \right) \right] \text{ displacement of}$$

particle at time $2T$ is zero.

Option (c) is correct.

Initial speed = $|\vec{v}| = v$

Final speed = $|\vec{v}| = v$

Option (d) is correct.

13.

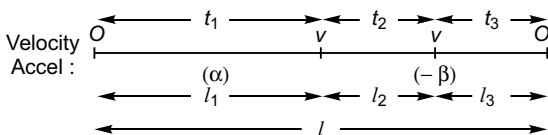

$$v = \alpha t_1 \quad v = \beta t_3$$

$$l_1 = \frac{1}{2} \alpha t_1^2, \quad l_2 = v t_2, \quad l_3 = \frac{1}{2} \beta t_3^2$$

$$= \frac{1}{2} v t_1 = \frac{1}{2} v t_3$$

$$\begin{aligned} t &= t_1 + t_2 + t_3 \\ &= \frac{2l_1}{v} + \frac{l_2}{v} + \frac{2l_3}{v} \\ &= \frac{l_1}{v} + \frac{l_2}{v} + \frac{l_3}{v} + \frac{l_1}{v} + \frac{l_3}{v} \\ &= \frac{l}{v} + \frac{1}{v} [l_1 + l_2] \\ &= \frac{l}{v} + \frac{1}{v} \left[\frac{1}{2} \alpha t_1^2 + \frac{1}{2} \beta t_2^2 \right] \\ &= \frac{l}{v} + v \left[\frac{1}{2} \frac{\alpha t_1^2}{v^2} + \frac{1}{2} \frac{\beta t_2^2}{v^2} \right] \\ &= \frac{l}{v} + v \left[\frac{1}{2} \frac{\alpha t_1^2}{\alpha^2 t_1^2} + \frac{1}{2} \frac{\beta t_2^2}{\beta^2 t_2^2} \right] \\ &= \frac{l}{v} + \frac{v}{2} \left[\frac{1}{\alpha} + \frac{1}{\beta} \right] \end{aligned}$$

Option (b) is correct.

For t to be minimum.

$$\frac{d}{dv} \left[\frac{l}{v} + \frac{v}{2} \left\{ \frac{1}{\alpha} + \frac{1}{\beta} \right\} \right] = 0$$

$$-\frac{l}{v^2} + \frac{1}{2} \left[\frac{1}{\alpha} + \frac{1}{\beta} \right] = 0$$

or

$$\frac{l}{v^2} = \frac{\alpha + \beta}{2\alpha\beta}$$

or

$$v = \sqrt{\frac{2l\alpha\beta}{\alpha + \beta}}$$

Option (d) is correct.

14. $x = t^2$ and $y = t^3 - 2t$

$$\frac{dx}{dt} = 2t \quad \text{and} \quad \frac{dy}{dt} = 3t^2 - 2$$

$$\text{At } t = 0, \quad \frac{dx}{dt} = 0 \quad \text{but} \quad \frac{dy}{dt} = -2$$

\therefore at $t = 0$ particle is moving parallel to y -axis.

Option (a) is correct.

Option (d) is incorrect.

$$\text{At } t = 0, \quad \vec{v} = -2 \hat{j}$$

$$\frac{d^2x}{dt^2} = 2$$

$$\text{and} \quad \frac{d^2y}{dt^2} = 6t$$

$$\text{At } t = 0, \quad \vec{a} = 2 \hat{i}$$

$$\text{i.e.,} \quad \vec{v} \perp \vec{a}$$

Option (b) is correct.

48 | Mechanics-1

At $t = \sqrt{\frac{2}{3}}$:

$$\frac{dx}{dt} = 2\sqrt{\frac{2}{3}} \text{ but } \frac{dy}{dt} = 3\left(\frac{2}{3}\right) - 2$$

∴ Particle is moving parallel to x -axis.

Option (c) is correct.

15.

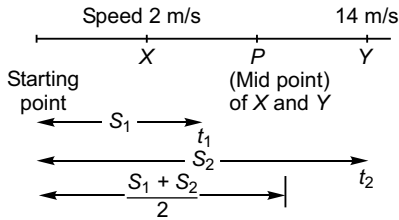

$$at_1 = 2 \text{ and } at_2 = 14$$

$$\therefore t_2 = 7t_1$$

$$S_1 + S_2 = \frac{1}{2}at_1^2 + \frac{1}{2}at_2^2$$

$$= \frac{1}{2}a(t_1^2 + t_2^2)$$

$$= \frac{1}{2}a[t_1^2 + (7t_1)^2]$$

$$= 25a t_1^2$$

$$\text{Speed } (v) \text{ at } \frac{S_1 + S_2}{2} :$$

$$v^2 = 2a \left(\frac{S_1 + S_2}{2} \right)$$

$$= a(S_1 + S_2)$$

$$= a(25a t_1^2)$$

$$\therefore v = 5a t_1$$

$$\text{or } v = 10 \text{ m/s}$$

Option (a) is correct.

Time t to reach P from T

$$10 = 2 + at$$

$$\Rightarrow t = \frac{8}{a} \quad \dots(i)$$

Time t' to reach Y from P

$$14 = 10 + at'$$

$$\therefore t' = \frac{4}{a} \quad \dots(ii)$$

Comparing Eq. (i) and Eq. (ii),

$$t = 2t'$$

Option (c) is correct.

Match the Columns

1. (a)

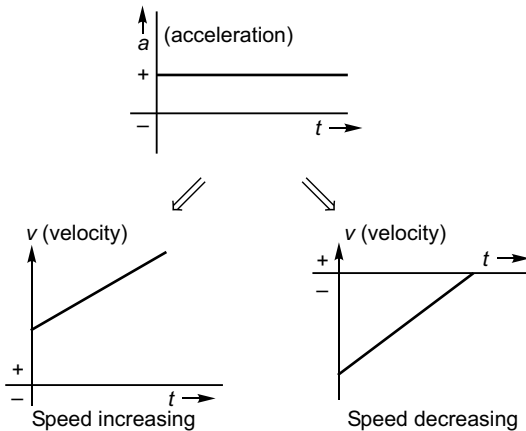

(a) (a) → (r) (s).

(b)

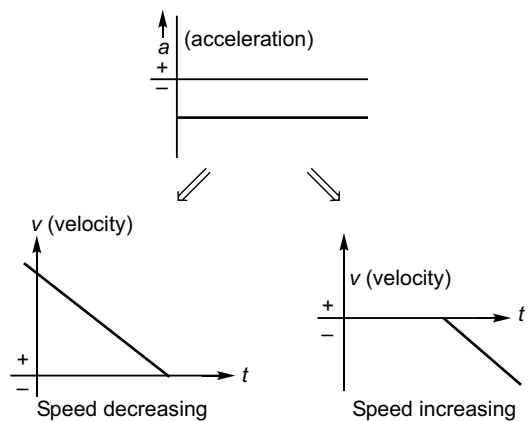

(b) (b) → (r) (s).

$$(c) s = kt^2$$

$$v = \frac{ds}{dt} = 2kt$$

$\therefore v$ must be increasing with time.
 \Rightarrow speed must also be increasing with time.

(c) \rightarrow (p).

(d) Slope is + ive and decreasing.

\therefore Velocity must be decreasing with time.

\Rightarrow speed must also be decreasing with time.

(d) \rightarrow (q).

2. (a) $\vec{v} = -2\hat{i}$

\therefore Initial speed = $|\vec{v}| = 2$

$$\vec{a} = -4\hat{j}$$

Velocity ($\vec{\omega}$) at time t

$$\begin{aligned}\vec{\omega} &= \vec{v} + \vec{a}t \\ &= -2\hat{i} - 4t\hat{j}\end{aligned}$$

Speed at time $t = |\vec{\omega}| = \sqrt{(-2)^2 + (-4t)^2}$

At $t > 0$

$$|\vec{\omega}| > |\vec{v}|$$

Speed increasing.

\therefore (a) \rightarrow (p).

(b) $\vec{v} = 2\hat{i}$

$$|\vec{v}| = 2$$

$$\vec{a} = 2\hat{i} + 2\hat{j}$$

Using $\vec{\omega} = \vec{v} + \vec{a}t$

$$\therefore \vec{\omega} = 2\hat{i} + 2t\hat{i} + 2t\hat{j}$$

$$\therefore |\vec{\omega}| = \sqrt{(2+2t)^2 + (2t)^2}$$

As $t > 0$, $|\vec{\omega}| > |\vec{v}|$

(a) \rightarrow (p).

(c) $\vec{v} = -2\hat{i}$ and $\vec{a} = +2\hat{i}$

Using $\vec{\omega} = \vec{v} + \vec{a}t$

$$\vec{\omega} = -2\hat{i} + 2t\hat{i}$$

or $\vec{\omega} = (2t - 2)\hat{i}$

$$\therefore |\vec{\omega}| = |2t - 2|$$

At $t = 0$ s Speed = $|\vec{\omega}| = 2$ m/s

$t = 1$ s $|\vec{\omega}| = 0$ m/s

$t = 2$ s $|\vec{\omega}| = 2$ m/s

$t = 3$ s $|\vec{\omega}| = 4$ m/s

\therefore (c) \rightarrow (s).

(d) $\vec{v} = 2\hat{i}$ and $\vec{a} = -2\hat{i} + 2\hat{j}$

$$\vec{\omega} = \vec{v} + \vec{a}t$$

$$= 2\hat{i} - 2t\hat{i} + 2t\hat{j}$$

$$= (2 - 2t)\hat{i} + 2t\hat{j}$$

$$|\vec{\omega}| = \sqrt{(2 - 2t)^2 + (2t)^2}$$

At $t = 0$ $|\vec{\omega}| = 2$

$$t = \frac{1}{2} \quad |\vec{\omega}| = \sqrt{2}$$

$$t = 1 \quad |\vec{\omega}| = 2$$

$$t = 2 \quad |\vec{\omega}| = \sqrt{20}$$

\therefore (d) \rightarrow (s).

3. (a) From A to B , v is increasing and area is + ive.

\therefore (a) \rightarrow (p).

(b) From B to C , v is increasing and area is + ive.

\therefore (b) \rightarrow (p).

(c) From C to D , v is decreasing while area is + ive.

\therefore (c) \rightarrow (q).

(d) From D to E , v is - ive and $|\vec{v}|$ is increasing, area is -ive.

\therefore (d) \rightarrow (r).

4. (a) Displacement = Area

$$= \frac{10 \times 4}{2} = 20 \text{ unit}$$

$$\therefore \text{Average velocity} = + \frac{20}{4} = + 5 \text{ unit}$$

i.e., (a) \rightarrow (r).

(b) Displacement = $+ 20 - \frac{1 \times 5}{2} = + 17.5$ unit

$$\therefore \text{Average velocity} = \frac{+ 17.5 \text{ unit}}{3}$$

$$= 5.83 \text{ unit}$$

\therefore (b) \rightarrow (s).

(c) Displacement = $+ 20 + \left(\frac{2 \times (-10)}{2}\right)$

$$= + 10 \text{ unit}$$

$$\therefore \text{Average velocity} = \frac{+ 10}{6}$$

i.e., (c) \rightarrow (s).

50 | Mechanics-1

(d) Rate of change of velocity at $t = 4$ s

$$\vec{a} = \frac{0 - 10}{4 - 2} = -5$$

\therefore Rate of change of speed at $t = 4$ s would be 5.

i.e., (d) \rightarrow (r).

5. (a) $x = -20 + 5t^2$

$$0 = -20 + 5t^2$$

$$\Rightarrow t = 2 \text{ s}$$

i.e., (a) \rightarrow (r).

(b) $x = -20 + 5t^2$

$$\frac{dx}{dt} = 10t$$

$$\frac{d^2x}{dt^2} = 10$$

Velocity will be numerically equal to acceleration at $t = 1$ s.

Thus (b) \rightarrow (q).

(c) At $t = 0$ s $x = -20$ m

$$t = 1 \text{ s} \quad x = -15 \text{ m}$$

$$t = 2 \text{ s} \quad x = 0 \text{ m}$$

$$t = 3 \text{ s} \quad x = +25 \text{ m}$$

Particle is always moving along +ive x -axis.

\therefore (c) \rightarrow (s).

(d) $v = \frac{dx}{dt} = 10t$ is zero at $t = 0$ s.

\therefore (d) \rightarrow (p).

6. (a) $x = 1 - 2t + t^2$

$$0 = 1 - 2t + t^2 \text{ [for particle to cross } y\text{-axis]}$$

i.e., $t = 1$ s

$$Y = 4 - 4t + t^2$$

$$\frac{dy}{dt} = -4 + 2t$$

$$= -4 + (2 \times 1) \quad \text{[at } t = 1 \text{ s]}$$

$$= -2 \text{ unit}$$

\therefore (a) \rightarrow (q).

(b) $Y = 4 - 4t + t^2$

$$0 = 4 - 4t + t^2 \text{ [For particle to cross } x\text{-axis]}$$

i.e., $t = 2$ s

$$x = 1 - 2t + t^2$$

$$\frac{dy}{dt} = -2 + 2t$$

$$= -2 + (2 \times 2) \quad \text{[at } t = 2 \text{ s]}$$

$$= +2 \text{ unit}$$

\therefore (b) \rightarrow (p).

(c) $\left(\frac{dx}{dt}\right)_{t=0 \text{ s}} = -2 \text{ unit}$

and $\left(\frac{dy}{dt}\right)_{t=0 \text{ s}} = -4 \text{ unit}$

\therefore Initial velocity of particle

$$= \sqrt{(-2)^2 + (-4)^2}$$

$$= 2\sqrt{5} \text{ unit}$$

i.e., (c) \rightarrow (s).

(d) $\frac{d^2x}{dt^2} = 2$

and $\frac{d^2y}{dt^2} = 2$

\therefore Initial acceleration of particle = $2\sqrt{2}$ unit

i.e., (d) \rightarrow (s).

Graphy

28. OA : slope is +ive and increasing.

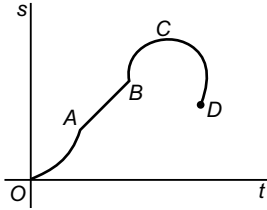

- ∴ velocity is +ive and acceleration is +ive.
- AB : slope is +ive and constant
- ∴ velocity is +ive and acceleration is zero.
- BC : slope is +ive and decreases.
- ∴ velocity is +ive and increasing.
- CD : slope is -ive and increasing
- ∴ velocity is -ive and acceleration is -ive.

29.

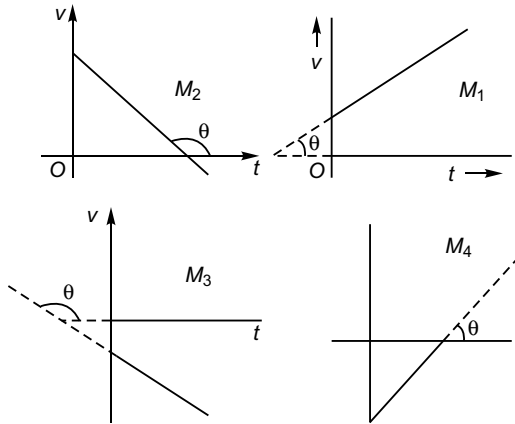

- In M_1 and M_3 : $0^\circ \leq \theta < 90^\circ$
- ∴ slope is +ive *i.e.*, acceleration is +ive.
- In M_2 and M_4 : $90^\circ < \theta \leq 180^\circ$
- ∴ slope is -ive *i.e.*, acceleration is -ive.
- (a) M_1 : Magnitude of velocity is increasing.
- M_2 : Magnitude of velocity is decreasing.
- M_3 : Magnitude of velocity is increasing.
- M_4 : Magnitude of velocity is decreasing.

Ans : M_1 and M_3 .

- (b) $P \rightarrow M_1$
- $Q \rightarrow M_2$
- $R \rightarrow M_3$
- $S \rightarrow M_4$

30. Case I

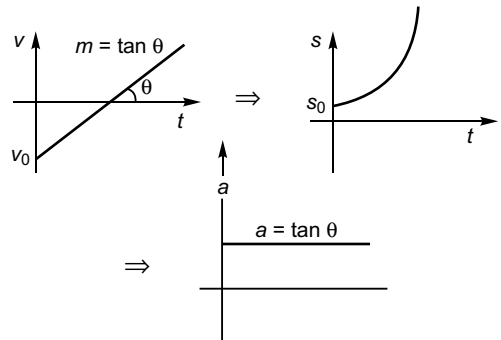

$$v = mt - v_0 \text{ (st-line)}$$

$$\therefore \int ds = \int (mt - v_0) dt$$

$$\text{i.e., } s = m \cdot \frac{t^2}{2} - v_0 t + s_0 \quad \text{(Parabola)}$$

$$\text{or } s = s_0 - v_0 t + \frac{1}{2} at^2 \quad (\because m = a)$$

$$\text{Further, } a = \frac{dv}{dt} = \tan \theta$$

As for $0^\circ \leq \theta < 90^\circ$
 $\tan \theta$ is +ive, a is +ive.

Case II

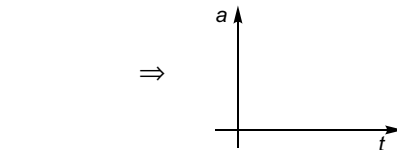
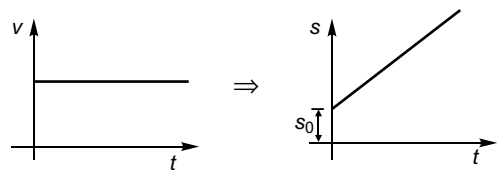

$v = k$ (constant) (st line parallel to time-axis)

$$\Rightarrow \int ds = \int k dt$$

$$s = kt + s_0$$

$$\text{Further, } a = \frac{dv}{dt} = 0$$

Case III.

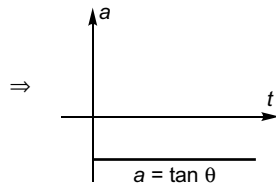
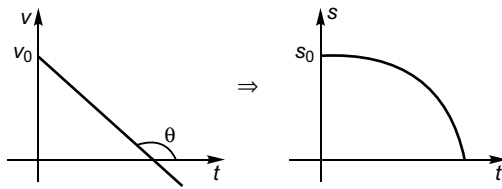

$$v = v_0 + mt$$

$$\therefore \int ds = \int (v_0 + mt) dt$$

i.e., $s = v_0 t + m \frac{t^2}{2} + s_0$

or $s = s_0 + v_0 t - \frac{1}{2} at^2$ ($\because m = -a$)

Further, $a = \frac{dv}{dt} = \tan \theta$

As for $90^\circ < \theta \leq 180^\circ$
 $\tan \theta$ is -ive, a is -ive.

Time-displacement graph

Time	Area under the graph	Initial Displacement	Net displacement
at 0 s	0 m	-10 m	-10 m
2 s	10 m	-10 m	0 m
4 s	30 m	-10 m	+20 m
6 s	40 m	-10 m	+30 m
8 s	30 m	-10 m	+20 m
10 s	20 m	-10 m	+10 m

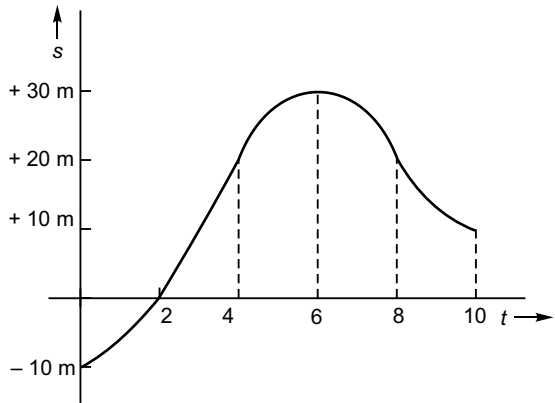

Time-acceleration graph

time	slope	acceleration
0 - 2 s	5	5 m/s ²
2 - 4 s	zero	0 m/s ²
4 - 6 s	-5	-5 m/s ²
6 - 8 s	-5	-5 m/s ²
8 - 10 s	+5	+5 m/s ²

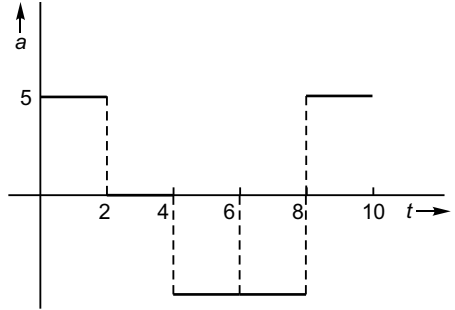

31. $a = \text{slope of } v-t \text{ graph.}$
 $S = \text{area under } v-t \text{ graph.}$
 Corresponding graphs are drawn in the answer sheet.
32. Average velocity = $\frac{s}{t} = \frac{\text{Net area}}{\text{Time}} = \frac{A_1 - A_2}{t}$
 Average speed = $\frac{d}{t} = \frac{A_1 + A_2}{t}$
33. Average acceleration
 $= \frac{v_f - v_i}{\text{time}} = \frac{-10 - 20}{6} = -5 \text{ m/s}^2$
 $v_f - v_i = \text{Area under } a-t \text{ graph.}$
34. (a) Acceleration = slope of $v-t$ graph.
 35. (b) $r_f - r_i = s = \text{area under } v-t \text{ graph.}$
 (c) Equations are written in answer sheet.

Relative Motion

35. (a) Acceleration of 1 w.r.t. 2
 $= (-g) - (-g)$
 $= 0 \text{ m/s}^2$
- (b) Initial velocity of 2 w.r.t. 1
 $= (+20) - (-5)$
 $= 25 \text{ m/s}$
- (c) Initial velocity of 1 w.r.t. 2
 $= (-5) - (+20)$
 $= -25 \text{ m/s}$

∴ Velocity of 1 w.r.t. 2 at time $t \left(= \frac{1}{2} \text{ s} \right)$

$$= (-25) + (0) \left(\frac{1}{2} \right)$$

$$= -25 \text{ m/s}$$

(d) Initial relative displacement of 2 w.r.t. 1

$$\vec{S}_0 = -20 \text{ m}$$

Using $\vec{S} = \vec{S}_0 + \vec{u}_{\text{rel}} t + \frac{1}{2} \vec{a}_{\text{rel}} t^2$,

as at time t (= time of collision of the particles) the relative displacement of 2 w.r.t. 1 will be zero (i.e., $\vec{S} = \vec{0}$)

$$\vec{0} = (-20) + (-25) \cdot \left(\frac{1}{2} \right)$$

$$\Rightarrow t = 0.85 \text{ s}$$

36. Let length of escalator L (= 15 m)

walking speed of man = $\frac{L}{90}$

Speed of escalator = $\frac{L}{60}$

Time taken by man walking on a moving escalator = $\frac{L}{\frac{L}{90} + \frac{L}{60}}$

$$= 36 \text{ s}$$

Required time has been found without using the actual length of the escalator.

37. \vec{S}_0 = Initial displacement of elevator w.r.t. ball = + 10 m.

Relative velocity of elevator w.r.t. ball

$$= (2) - (18) = -16 \text{ m/s}$$

Accelerator of elevator w.r.t. ball

$$= (0) - (-10)$$

$$= 10 \text{ m/s}^2$$

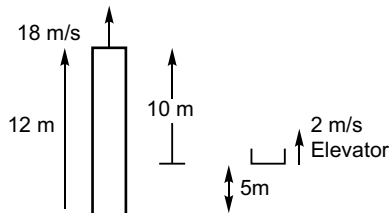

Using $\vec{S} = \vec{S}_0 + u_{\text{rel}} t + \frac{1}{2} a_{\text{rel}} t^2$

$$0 = (+10) + (-16)t + \frac{1}{2}(+10)t^2$$

or $5t^2 - 16t - 10 = 0$

$$t = 3.65 \text{ s}$$

Position of elevator when it meets ball

$$= 5 + (2 \times 3.65)$$

$$= 12.30 \text{ m level}$$

38.

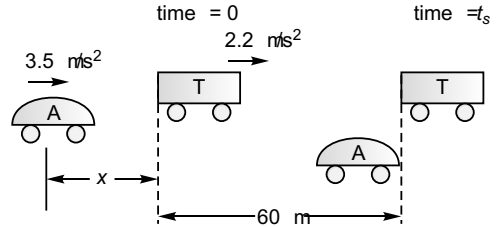

(a) $\frac{1}{2}(2.2)t^2 = 60$... (i)

$$\Rightarrow t = 7.39 \text{ s}$$

(b) $\frac{1}{2}(3.5)t^2 = 60 + x$... (ii)

Dividing Eq. (ii) by Eq. (i),

$$\frac{60 + x}{60} = \frac{3.5}{2.2}$$

or $\frac{x}{60} = \frac{1.3}{2.2}$

$$x = 35.5 \text{ m}$$

(c) At the time of overtaking

Speed of automobile = $(3.5)(7.39)$

$$= 25.85 \text{ m/s}$$

Speed of truck = $(2.2)(7.39)$

$$= 16.25 \text{ m/s}$$

39. Let, acceleration of lift = a (upward)

∴ acceleration of thrown body w.r.t. lift

$$= (-g) - (+a)$$

$$= -(g + a)$$

If time of flight is t , using

$$v_{\text{rel}} = u_{\text{rel}} + a_{\text{rel}} t$$

$$(-v) = (+u) + \{-(g + a)\} t$$

$$\Rightarrow (a + g)t = 2u$$

or $a = \frac{2u}{t} - g$

30 | Mechanics-1

40.

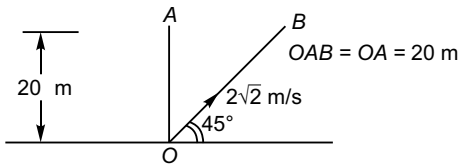

$$OB = \sqrt{(OA)^2 + (AB)^2}$$

$$= \sqrt{(20)^2 + (20)^2}$$

$$= 20\sqrt{2} \text{ m}$$

Speed along OB is $2\sqrt{2}$ m/s

$$\therefore \text{Time taken to reach } B = \frac{20\sqrt{2} \text{ m}}{2\sqrt{2} \text{ ms}^{-1}}$$

$$= 10 \text{ s}$$

41. In $\triangle OPQ$,

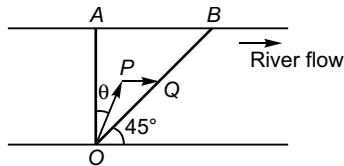

$$OP = |\vec{v}_{br}|$$

$$OP = |\vec{v}_r|$$

$$\frac{PQ}{\sin \angle POQ} = \frac{OP}{\sin \angle OPQ}$$

$$\frac{2}{\sin(45^\circ - \theta)} = \frac{4}{\sin 45^\circ}$$

$$\theta = \left[\sin^{-1} \left(\frac{1}{2\sqrt{2}} \right) - 45^\circ \right]$$

42. Let pilot heads point R to reach point Q

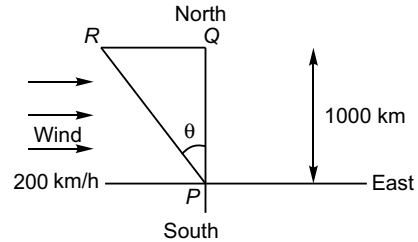

$$\sin \theta = \frac{RQ}{PR}$$

$$= \frac{200t}{500t}$$

\Rightarrow

$$\theta = \sin^{-1}(0.4)$$

$$(PR)^2 = (RQ)^2 + (PQ)^2$$

or

$$(500t)^2 - (200t)^2 = (1000)^2$$

or

$$t = \frac{1000}{\sqrt{(500)^2 - (200)^2}}$$

$$= \frac{10}{\sqrt{25 - 4}} = \frac{10}{\sqrt{21}} \text{ h}$$

Objective Questions (Level 1)

Single Correct Option

1. As the packet is detached from rising balloon its acceleration will be g in the downward direction.

Option (b) is correct.

2. While going up :

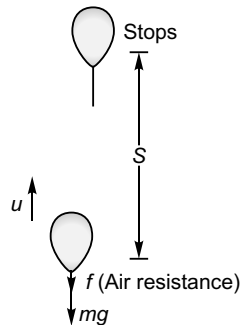

$$0 = u - \left(\frac{mg + f}{m} \right) T_1$$

$$T_1 = \frac{um}{mg + f}$$

...(i)

Using $v^2 = u^2 + 2as$

$$0^2 = u^2 - 2 \left(\frac{mg + f}{m} \right) s$$

i.e.,

$$S = \frac{mu^2}{2(mg + f)}$$

While coming down

$$s = \frac{1}{2} \left(\frac{mg - f}{m} \right) T_2^2$$

or

$$\frac{mu^2}{2(mg + f)} = \frac{1}{2} \left(\frac{mg - f}{m} \right) T_2^2$$

$$\Rightarrow T_2 = \frac{um}{\sqrt{(mg+f)(mg-f)}} \dots \text{(ii)}$$

Using Eq. (i) and Eq. (ii)

$$\frac{T_2}{T_1} = \sqrt{\frac{mg+f}{mg-f}}$$

$$\Rightarrow T_2 > T_1$$

Option (c) is correct.

3. Angular speed (ω) of seconds hand

$$= \frac{2\pi}{60} \text{ rad s}^{-1}$$

Speed of the tip of seconds hand

$$v = \frac{\pi}{30} \times 1 \text{ cm/s} \quad [\because v = r\omega \quad \text{and} \\ r = 1 \text{ cm}]$$

As in 15s the seconds hand rotates through 90° , the change in velocity of its tip in 15 s will be

$$= v\sqrt{2} = \frac{\pi\sqrt{2}}{30} \text{ cm s}^{-1}$$

Option (d) is correct.

4. Average speed = $\frac{5+5}{\frac{5}{30} + \frac{5}{60}} = 40 \text{ ms}^{-1}$

Option (c) is correct.

5. Relative velocity of boat w.r.t. water

$$= (3\hat{i} + 4\hat{j}) - (-3\hat{i} - 4\hat{j}) = 6\hat{i} + 8\hat{j}$$

Option (b) is correct.

6. $21 = \frac{(18 \times 11) + (42 \times v)}{18 + 42}$

$$\Rightarrow v = 25.29 \text{ m/s}$$

7. $x = 32t - \frac{8t^3}{3}$

$$v = \frac{dx}{dt} = 32 - 8t^2 \quad \dots \text{(i)}$$

\therefore Particle is at rest when

$$32 - 8t^2 = 0$$

$$\text{i.e.,} \quad t = 2 \text{ s}$$

Differentiating Eq. (i) w.r.t. time t

$$a = \frac{dv}{dt} = -16t$$

$\therefore a$ at time $t = 2 \text{ s}$ (when particle is at rest)

$$= -(16) \times (2) = -32 \text{ m/s}^2$$

Option (b) is correct.

8. For first one second

$$2 = \frac{1}{2} a \times 1^2$$

$$\Rightarrow a = 4 \text{ m/s}^2$$

Velocity at the end of next second

$$v = (4) \times (2)$$

$$= 8 \text{ m/s}$$

Option (b) is correct.

9. $x = -3t + t^3$

\therefore displacement at time $t (= 1 \text{ s})$

$$= -3(1) + (1)^3 = -2 \text{ m}$$

and displacement at time $t (= 3 \text{ s})$

$$= -3(3) + (3)^3 = 18 \text{ m}$$

And as such displacement in the time interval ($t = 1 \text{ s}$ to $t = 3 \text{ s}$)

$$= (18 \text{ m}) - (-2 \text{ m})$$

$$= +20 \text{ m}$$

Option (c) is correct.

10. Acceleration $a = bt$

$$\therefore \frac{dv}{dt} = bt$$

$$\text{or} \quad \int dv = \int bt dt$$

$$\text{or} \quad v = \frac{1}{2} bt^2 + C$$

Now, at $t = 0, v = v_0$

$$\therefore C = v_0$$

$$\text{i.e.,} \quad v = \frac{1}{2} bt^2 + v_0$$

$$\text{or} \quad \frac{ds}{dt} = v_0 + \frac{1}{2} bt^2$$

$$\text{or} \quad \int ds = \int \left(v_0 + \frac{1}{2} bt^2 \right) dt$$

$$\text{or} \quad s = v_0 t + \frac{1}{6} bt^3 + k$$

At $t = 0, s = 0,$

$$\therefore k = 0$$

$$\Rightarrow s = v_0 t + \frac{1}{6} bt^3$$

Option (a) is correct.

32 | Mechanics-1

11. $\frac{1}{2}g(2t^2 + 6)$ m (given)

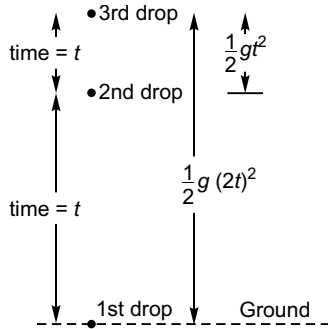

$\therefore \frac{1}{2}gt^2 = \frac{5}{4}$ m

\therefore Height of 2nd drop from ground
 $= 5 \text{ m} - \frac{5}{4} \text{ m}$
 $= 3.75 \text{ m}$

Option (c) is correct.

12.

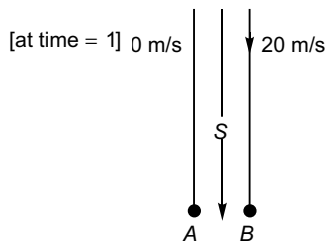

[At time = $t - 1$]

$s = \frac{1}{2} \times 10t^2$
 $= 20(t - 1) + \frac{1}{2} \times 10(t - 1)^2$

or $t^2 = 4(t - 1) + (t^2 - 2t + 1)$

or $2t - 3 = 0$

or $t = \frac{3}{2}$ s

$\therefore s = \frac{1}{2} \times 10 \times \left(\frac{3}{2}\right)^2$
 $= 11.25 \text{ m}$

Option (c) is correct.

$\therefore v = t \hat{i} + \frac{t^3}{2} \hat{j}$

Thus, velocity of particle at time $t (= 2 \text{ s})$ will be

$v_2 = 2 \hat{i} + 4 \hat{j}$

Option (b) is correct.

13. $v_0^2 = 2gh$ and $u^2 = 2g(3h)$

$\therefore \frac{u^2}{v_0^2} = 3$

or $u = v_0 \sqrt{3}$

Option (a) is correct.

14. $v_x = 8t - 2$

$\therefore \frac{dx}{dt} = 8t - 2$

or $\int dx = \int (8t - 2) dt$

or $x = 4t^2 - 2t + k_1$

Now at $t = 2$, $x = 14$

$\therefore 14 = 4 \cdot 2^2 - (2)2 + k_1$

i.e., $k_1 = 2$

Thus, $x = 4t^2 - 2t + 2$... (i)

Further, $v_y = 2$

i.e., $\frac{dy}{dt} = 2$

or $\int dy = \int 2 dt$

or $y = 2t + k_2$

Now, at $t = 2$, $y = 4$

$\therefore k_2 = 0$

Thus, $y = 2t$... (ii)

Substituting $t = \frac{y}{2}$ in Eq. (i),

$x = 4 \left(\frac{y}{2}\right)^2 - 2 \left(\frac{y}{2}\right) + 2$

or $x = y^2 - y + 2$

Option (a) is correct.

15. $x = 5t$ and $y = 2t^2 + t$

$\therefore \frac{dx}{dt} = 5$ and $\frac{dy}{dt} = 4t + 1$

Now, $\frac{dy}{dx} = \frac{dy/dt}{dx/dt}$

$\tan 45^\circ = \frac{4t + 1}{5}$

$\Rightarrow t = 1 \text{ s}$

Option (b) is correct.

16. $y = 8t - 5t^2$ and $x = 6t$

$\therefore \frac{dy}{dt} = 8 - 10t$ and $\frac{dx}{dt} = 6$

At $t = 0$

$$\frac{dy}{dt} = 8 \text{ and } \frac{dx}{dt} = 6$$

\therefore Velocity of projection

$$= \sqrt{\left(\frac{dx}{dt}\right)^2 + \left(\frac{dy}{dt}\right)^2} = \sqrt{6^2 + 8^2} = 10 \text{ ms}^{-1}$$

Option (c) is correct.

17. $T = \sqrt{\frac{2H}{g}}$

$\therefore \frac{T}{3} = \sqrt{\frac{2}{g} \left(\frac{H}{9}\right)}$

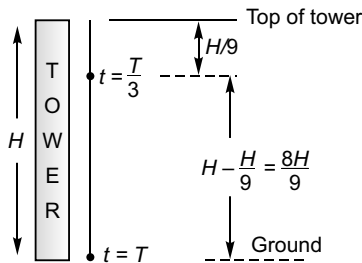

Option (c) is correct.

18. Distance of farthest corner from one corner

$$= a + a + a = 3a$$

\therefore Time taken $= \frac{3a}{u}$

Option (a) is correct.

19. Time-velocity graph of the given time-acceleration graph will be

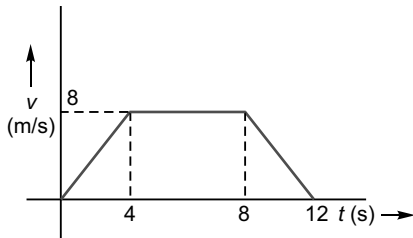

\therefore Height of lift above the starting point when it comes to rest

$$= \text{Area under } t\text{-}v \text{ graph} = \frac{4 + 12}{2} \times 8 = 64 \text{ m}$$

Option (b) is correct.

20.

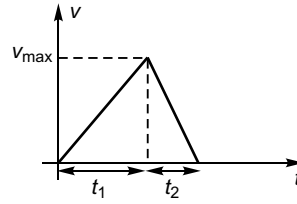

In time interval t_1

$$\text{Acceleration} = \frac{v_{\max}}{t_1} = a$$

In time interval t_2

$$\text{Retardation} = \frac{v_{\max}}{t_2} = 2a$$

$$\therefore \frac{v_{\max}}{t_2} = 2 \cdot \frac{v_{\max}}{t_1}$$

i.e., $t_1 = 2t_2$

Now $t_1 + t_2 = t$

$\therefore 2t_2 + t_2 = t$

or $t_2 = \frac{t}{3}$

Depth of shaft = Displacement of lift

$$= \frac{1}{2} v_{\max} (t_1 + t_2)$$

$$= \frac{1}{2} v_{\max} (2t_2 + t_2)$$

$$= \frac{3}{2} v_{\max} t_2$$

$$= \frac{3}{2} (2at_2) t_2$$

$$= 3at_2^2$$

$$= 3a \left(\frac{t}{3}\right)^2$$

$$= \frac{at^2}{3}$$

Option (b) is correct.

21. $s = 2ut + \frac{1}{2} at^2 = ut + \frac{1}{2} 2at^2$

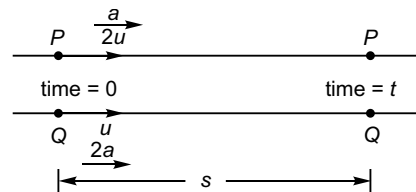

$$\Rightarrow ut - \frac{1}{2} at^2 = 0$$

34 | Mechanics-1

or $u - \frac{1}{2}at = 0$

or $t = \frac{2u}{a}$

$\therefore s = 2u\left(\frac{2u}{a}\right) + \frac{1}{2}a\left(\frac{2u}{a}\right)^2$
 $= \frac{4u^2}{a} + \frac{2u^2}{a}$
 $= \frac{6u^2}{a}$

Option (a) is correct.

22. u = vertical speed (w.r.t. cart) of the particle.

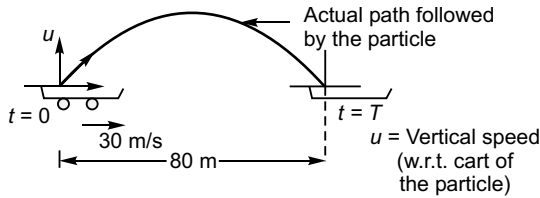

For cart $T = \frac{80 \text{ m}}{30 \text{ m/s}} = \frac{8}{3} \text{ s}$

For particle $0 = uT + \frac{1}{2}(-g)T^2$

i.e., $\frac{1}{2}gT^2 = uT$

$T = \frac{2u}{g} = \frac{8}{3}$

i.e., $\frac{2u}{10} = \frac{8}{3}$

or $u = \frac{40}{3} \text{ ms}^{-1}$

Option (c) is correct.

23. $A_1 = \frac{1}{2}(+10)(+1) = +5 \text{ m}$
 $A_2 = \frac{1}{2}(-10)(+1) = -5 \text{ m}$

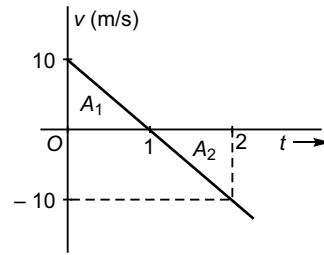
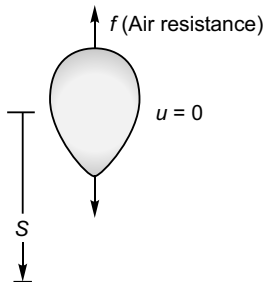

\therefore Displacement of particle at time ($t = 2$)
 $= (+5 \text{ m}) + (-5 \text{ m})$
 $= 0 \text{ m}.$

i.e., the particle crosses its initial position at $t = 2 \text{ s}.$

Option (b) is correct.

24. As downward direction is considered to be +ive, velocity of ball at $t = 0$ will be $-v_0.$

Thus, option (a) and (c) are incorrect.

Now, as the ball will have +ive acceleration throughout its motion option (b) is also incorrect.

\therefore Correct option is (d).

25. Let acceleration of lift = a (upwards)

Displacement of ball in time t
 $=$ Displacement of lift in time t

$v_0t - \frac{1}{2}gt^2 = \frac{1}{2}at^2$

or $v_0 - \frac{gt}{2} = \frac{at}{2}$

$\therefore a = \frac{2v_0 - gt}{t}$

Option (a) is correct.

26. $a = -0.2v^2$

$\therefore \frac{dv}{dt} = -0.2v^2$

or $\int v^{-2} dv = -0.2 \int dt$

or $\frac{v^{-2+1}}{-2+1} = -0.2t + C$

or $-\frac{1}{v} = -0.2t + C$

Now, at $t = 0, v = 10 \text{ m/s}$ (given)

$\therefore -\frac{1}{10} = 0 + C$

i.e., $C = -\frac{1}{10}$

Thus, $-\frac{1}{v} = -0.2t - \frac{1}{10}$

∴ For velocity v at time $t (= 2 \text{ s})$

$$-\frac{1}{v} = -(0.2 \times 2) - \frac{1}{10}$$

$$-\frac{1}{v} = -\frac{4}{10} - \frac{1}{10}$$

$$\frac{1}{v} = \frac{1}{2}$$

⇒ $v = +2 \text{ m/s.}$

Option (a) is correct.

27. For displacement (S_1) of train 1 before coming to rest

$$0^2 = (10)^2 + 2(-2)S_1$$

i.e., $S_1 = 25 \text{ m}$

For displacement (S_2) of train 2 before coming to rest

$$0^2 = (20)^2 + 2(-1)S_2$$

i.e., $S_2 = 200 \text{ m}$

∴ $S_{\min} = S_1 + S_2$
 $= 225 \text{ m}$

Option (b) is correct.

28. Let the balls collide after time t the first ball is shot.

∴ displacement (S) of ball 1 at time t
 = displacement (S) of ball 2 at time $(t - 2)$

$$40t + \frac{1}{2}(-g)t^2 = 40(t - 2) + \frac{1}{2}(-g)(t - 2)^2$$

or $\frac{1}{2}g[t^2 - (t - 2)^2] = 80$

or $(t + t - 2)(t - t + 2) = 16$

or $2t - 2 = 8$

or $t = 5 \text{ s}$

$$S = 40 \times 5 + \frac{1}{2}(-10)5^2$$

$$= 200 - 125$$

$$= 75 \text{ m}$$

Option (b) is correct.

29. $0 = u - gT$

i.e., $u = gT$... (i)

$$H = uT - \frac{1}{2}gT^2$$
 ... (ii)

and $h = ut - \frac{1}{2}gt^2$... (iii)

Subtracting Eq. (ii) from Eq. (iii),

$$h - H = u(t - T) + \frac{1}{2}g(T^2 - t^2)$$

$$= gT(t - T) - \frac{1}{2}g(t - T)(t + T)$$

$$= (t - T)g \left[T - \frac{1}{2}(t + T) \right]$$

$$= (t - T)g \left[\frac{2T - t - T}{2} \right]$$

$$= -\frac{1}{2}g(t - T)^2$$

i.e., $h = H - \frac{1}{2}g(t - T)^2$

Option (d) is correct.

30. $x = \frac{t^2}{2}$

∴ $v_x = \frac{dx}{dt} = t$

$$y = \frac{x^2}{2} = \frac{(t^2/2)^2}{2} = \frac{t^4}{8}$$

∴ $v_y = \frac{dy}{dt} = \frac{t^3}{2}$

31. $\sqrt{x} = t + 3$

i.e., $x = t^2 + 6t + 3$

$$\frac{dx}{dt} = 2t + 6$$

i.e., $v \propto t$

Option (b) is correct.

32. Aeroplane's velocity at time $t (= 20 \text{ s})$

= Area under curve (t - a graph)

$$= (20 \times 5) - \left(\frac{1}{2} \times 10 \times 2 \right)$$

$$= 90 \text{ m/s}$$

Option (c) is correct.

33. $v = 5\sqrt{1+5}$... (i)

At $s = 0$ (i.e., initially),
 velocity of particle = 5 m/s

Option (b) is correct.

Differentiating equation (i) w.r.t. s

$$\frac{dv}{ds} = 5 \frac{1}{2} (1+5)^{-\frac{1}{2}}$$

$$v \cdot \frac{dv}{ds} = \frac{5}{2} (1+5)^{-\frac{1}{2}} \cdot 5 (1+5)^{\frac{1}{2}}$$

$$= 12.5 \text{ m/s}^2$$

36 | Mechanics-1

Option (b) is correct.

34. See answer to question no. 2.

$$\begin{aligned} \frac{\text{Time of ascent}}{\text{Time of descent}} &= \sqrt{\frac{mg-f}{mg+f}} \\ &= \sqrt{\frac{mg-ma}{mg+ma}} \\ &= \sqrt{\frac{g-a}{g+a}} \\ &= \sqrt{\frac{10-2}{10+2}} \\ &= \sqrt{\frac{2}{3}} \end{aligned}$$

Option (b) is correct.

35.

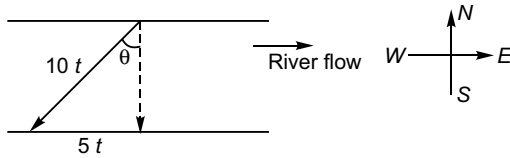

$$\sin \theta = \frac{5t}{10t} = \frac{1}{2}$$

$$\Rightarrow \theta = 30^\circ$$

Option (b) is correct.

36. $F_{\text{net}} = 3t^2 - 32$

i.e., $ma_{\text{net}} = 3t^2 - 32$

or $a_{\text{net}} = \frac{3t^2 - 32}{10}$

or $a_{\text{net}} = 0.3t^2 - 3.2$

or $\frac{dv}{dt} = 0.3t^2 - 3.2$

or $\int dv = \int (0.3t^2 - 3.2) dt$

or $v = \frac{0.3t^3}{3} - (3.2)t + k$

or $v = 0.1t^3 - (3.2)t + k$

Now, at $t = 0, v = 10 \text{ m/s}$

$\therefore 10 = k$

Thus, $v = 0.1t^3 - (3.2)t + 10$

\therefore at $t = 5 \text{ s}$

$$v = 0.1(5)^3 - (3.2)(5) + 10$$

$$\begin{aligned} &= 12.5 - 16.0 + 10 \\ &= 6.5 \text{ m/s} \end{aligned}$$

Option (b) is correct.

37. $u^2 = 2gH$

$$\Rightarrow H = \frac{u^2}{2g}$$

$$10^2 = u^2 - 2g \frac{H}{2}$$

$$\Rightarrow u^2 = 100 + gH$$

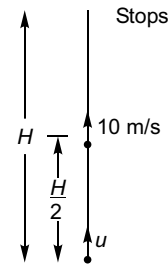

Thus, $H = \frac{100 + gH}{2g}$

or $gH = 100$

$$\Rightarrow H = 10 \text{ m}$$

Option (b) is correct.

38.

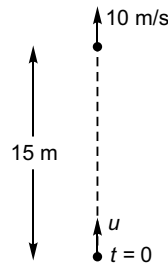

$$10^2 = u^2 - 2g \times 15$$

$$100 = u^2 - 2 \times 10 \times 15$$

i.e., $u = 20 \text{ m/s}$

Now, $v = u - gt = 20 - 10 \times 3$

$$= 20 - 10 \cdot (3)$$

$$= -10 \text{ m/s, downward}$$

Option (d) is correct.

JEE Corner

Assertion and Reason

1. As acceleration (\vec{a}) is just opposite to velocity (\vec{v}), the particle will move along a straight line.

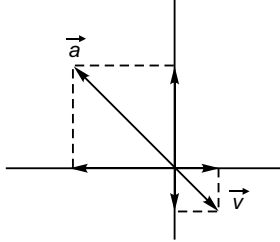

\therefore Assertion is false (motion being one dimensional).

Reason is true as \vec{v} and \vec{a} do not depend upon time.

Option (d) is correct.

2. Displacement-time graph is parabolic only when the slope of the straight line velocity-time graph is not zero i.e., acceleration is not zero.

If acceleration is zero.

$$s = ut$$

i.e., the displacement-time graph will be a straight line.

\therefore Assertion is wrong.

Reason : $v = u + at$

i.e., $\frac{ds}{dt} = u + at$

or $\int ds = \int (u + at) dt$
 $s = ut + \frac{1}{2}at^2 + k$

If at $t = 0, s = 0$

The value of k will be zero.

$\therefore s = ut + \frac{1}{2}at^2$

Thus, reason is true.

3. Displacement in time t_0
 = Area under $v-t$ graph
 $= \frac{1}{2}v_0t_0$

\therefore average velocity in time interval t_0

$$= \frac{\text{Displacement}}{t_0}$$

$$= \frac{\frac{1}{2}v_0t_0}{t_0} = \frac{v_0}{2}$$

\therefore Assertion is true.

Reason is also true as proved.

4. Acceleration (a) will be zero only when velocity does not change with time

$$a = v \cdot \frac{dv}{ds}$$

$$= \frac{ds}{dt} \cdot \frac{dv}{ds}$$

$$= \frac{dv}{dt}$$

$\therefore a = 0$ if $\frac{dv}{dt} = 0$

or v is constant with time.

Thus, Assertion is wrong.

Reason is correct as a is equal to $\frac{dv}{dt}$ which is instantaneous acceleration.

5. If acceleration is in the opposite direction to the velocity of the particle the speed will decrease.

$$u = 10 \text{ m/s}$$

$$a = -2t \text{ m/s}^2$$

$$\frac{dv}{dt} = -2t$$

$$\int dv = \int -2t dt$$

$$v = -2 \cdot \frac{t^2}{2} + k$$

At $t = 0$ s, velocity = + 10 m/s

$\therefore k = + 10 \text{ m/s}$

$\therefore v = -t^2 + 10$

Time (t)	v m/s	speed (m/s)
15	9	9
25	6	6
35	1	1

\therefore Assertion is true.

38 | Mechanics-1

Reason is false as when acceleration is positive the speed will increase.

6. $\frac{da}{dt} = 2 \text{ (ms}^{-3}\text{)}$ (given)

[This implies that reason is true]

$$\int da = \int 2 dt$$

$$a = 2t + C$$

If at $t = 0, a = 0$

we have $C = 0$

$\therefore a = 2t$

or $\frac{dv}{dt} = 2t$

\therefore Assertion is false.

Option (d) is correct.

7. If initially particle velocity is - ive and acceleration is uniform and +ive, the particle will return to its initial position after a certain time interval. In this time interval the average velocity will be zero as net displacement will be zero.

\therefore Assertion is false.

For average velocity to zero, the particle must return to its initial position (as discussed above) and for this velocity can't remain constant.

\therefore Reason is true.

Option (d) is correct.

8. From O to A velocity of the particle is increasing while from A to B it is decreasing without change in direction as for the velocity to change its direction the slope of s - t graph must be negative.

\therefore Assertion is false.

If the slope of s - t graph is +ive the velocity of the particle will be +ive while if it is -ive the velocity of the particle will also be -ive.

\therefore Reason is true.

9. $S_1 = 2t - 4t^2$

and $S_2 = -2t + 4t^2$

\Rightarrow displacement of particle 2 w.r.t. 1.

$$S_{21} = S_2 - S_1$$

$$= (-2t + 4t^2) - (2t - 4t^2)$$

$$= -4t + 8t^2$$

Time t	Relative Displacement
0 s	0 m
1 s	4 m
2 s	24 m
3 s	60 m

As relative displacement is increasing the relative velocity would also be increasing.

\therefore Assertion is false.

Reason is true.

10. If $v = u + (-a)t$ [acceleration being made -ive]

Velocity (v) of the particle will be zero

at $t = \frac{u}{a}$

Thus, for $t < \frac{u}{a}$, v is +ive

i.e., the acceleration can change its direction without change in direction of velocity.

\therefore Assertion is true.

If ΔV changes sign say from +ive to -ive, the acceleration which equals $\frac{\Delta V}{\Delta t}$ will also

change sign from +ive to -ive.

\therefore Reason is true but it is not the correct explanation of the assertion.

11. At time t when the two are at the same height.

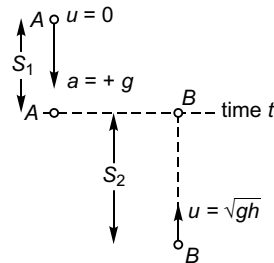

$$S_1 + S_2 = h$$

$$\left(\frac{1}{2}gt^2\right) + \left(ut - \frac{1}{2}gt^2\right) = h$$

$$ut = h$$

$$\sqrt{gh} \cdot t = h$$

$$t = \sqrt{\frac{h}{g}}$$

4

Projectile Motion

Introductory Exercise 4.1

1. A particle projected at any angle with horizontal will always move in a plane and thus projectile motion is a 2-dimensional motion. The statement is thus **false**.
2. At high speed the projectile may go to a place where acceleration due to gravity has some different value and as such the motion may not be uniform accelerated. The statement is thus **true**.
3. See article 4.1.
4. $u = 40\sqrt{2}$ m/s, $\theta = 45^\circ$
As horizontal acceleration would be zero.

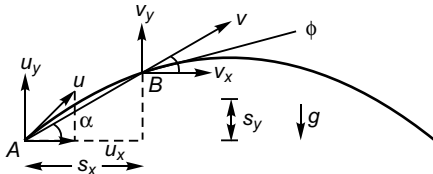

$$v_x = u_x = u \cos \theta = 40 \text{ m/s}$$

$$s_x = u_x t = (u \cos \theta) t = 80 \text{ m}$$

A : position of particle at time = 0.

B : position of particle at time = t.

As vertical acceleration would be $-g$

$$\begin{aligned} v_y &= u_y - gt \\ &= u \sin \theta - gt \\ &= 40 - 20 \\ &= 20 \text{ m/s} \end{aligned}$$

$$s_y = u_y \cdot t - \frac{1}{2}gt^2$$

$$= 80 - \frac{1}{2} \times 10 \times 2^2 = 60 \text{ m}$$

$$\begin{aligned} \therefore v &= \sqrt{v_x^2 + v_y^2} \\ &= \sqrt{40^2 + 20^2} \\ &= 20\sqrt{5} \text{ m/s} \\ \tan \phi &= \frac{v_y}{v_x} = \frac{20}{40} \end{aligned}$$

$$\text{i.e., } \phi = \tan^{-1}\left(\frac{1}{2}\right)$$

$$\begin{aligned} s &= \sqrt{s_x^2 + s_y^2} \\ &= \sqrt{80^2 + 60^2} \\ &= 100 \text{ m} \\ \tan \alpha &= \frac{s_y}{s_x} \\ &= \frac{60}{80} \end{aligned}$$

$$\text{i.e., } \alpha = \tan^{-1}\left(\frac{3}{4}\right)$$

$$5. s_y = u_y t + \frac{1}{2}(-g)t^2$$

$$\text{or } s_y = (u \sin \theta)t - \frac{1}{2}gt^2$$

$$\text{or } 15 = 20t - \frac{1}{2}gt^2$$

$$\text{or } t^2 = 4t + 3 = 0$$

$$\text{i.e., } t = 1 \text{ s and } 3 \text{ s}$$

6. See figure to the answer to question no. 4.

$$u = 40 \text{ m/s}, \theta = 60^\circ$$

$$\therefore u_x = 40 \cos 60^\circ = 20 \text{ m/s}$$

52 | Mechanics-1

Thus, $v_x = u_x = 20 \text{ m/s}$

As $\phi = 45^\circ$

$$\tan \phi = \frac{v_y}{v_x} = 1$$

$$\therefore y_y = v_x = 20 \text{ m/s}$$

$$\begin{aligned} \text{Thus, } v &= \sqrt{v_x^2 + v_y^2} = v_x \sqrt{2} \\ &= 20\sqrt{2} \text{ m/s} \end{aligned}$$

Before reaching highest point

$$v_y = u_y + (-g)t$$

$$\therefore 20 = 40 \sin 60^\circ - 10t$$

$$\text{or } 2 = 2\sqrt{3} - t$$

$$\Rightarrow t = 2(\sqrt{3} - 1) \text{ s}$$

After attaining highest point

$$-20 = 40\sqrt{3} - 10t$$

$$\text{i.e., } -2 = 2\sqrt{3} - t$$

$$\text{or } t = 2(\sqrt{3} + 1) \text{ s}$$

$$7. \text{ Average velocity} = \frac{\text{Range}}{\text{Time of flight}}$$

$$\begin{aligned} &= \frac{u^2 \sin 2\alpha / g}{2u \sin \alpha / g} \\ &= \frac{2u^2 \sin \alpha \cos \alpha}{g} \times \frac{g}{2u \sin \alpha} \\ &= u \cos \alpha \end{aligned}$$

8. Change in velocity

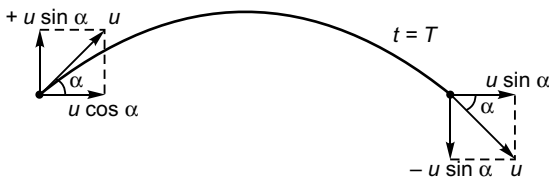

$$\begin{aligned} &= (-u \sin \alpha) - (+u \sin \alpha) \\ &= -2u \sin \alpha \\ &= 2u \sin \alpha \text{ (downward)} \end{aligned}$$

9. Formulae for R , T and H_{\max} will be same if the projection point and the point where the particle lands are same and lie on a horizontal line.

$$10. \vec{r} = [3t \hat{i} + (4t - 5t^2) \hat{j}] \text{ m}$$

y -coordinate will be zero when

$$4t - 5t^2 = 0$$

$$\text{i.e., } t = 0 \text{ s, } \frac{4}{5} \text{ s}$$

$t = 0$ belongs to the initial point of projection of the particle.

$$\therefore \vec{r} = 0 \hat{i} \text{ m}$$

$$\text{i.e., } x = 0 \text{ m}$$

At $t = 0.8 \text{ s}$,

$$\vec{r} = 2.4 \hat{i} \text{ m}$$

$$\text{i.e., } x = 2.4 \text{ m}$$

$$11. v_x = u_x = 10 \text{ m/s}$$

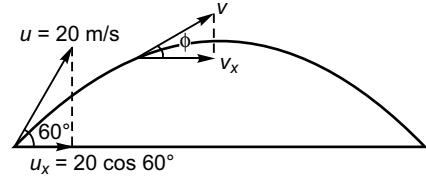

$$= 10 \text{ m/s}$$

$$v_x = u_x = 10 \text{ m/s}$$

$$v_x = v \cos \phi$$

$$\Rightarrow \cos \phi = \frac{v_x}{v}$$

$$= \frac{10}{v}$$

$$= \frac{10}{10}$$

$$[\text{as, } v = \frac{20}{2} \text{ (given)}]$$

$$= 1$$

$$\text{i.e., } \phi = 0^\circ$$

\therefore Speed will be half of its initial value at the highest point where $\phi = 0^\circ$.

$$\text{Thus, } t = \frac{u \sin \theta}{g}$$

$$= \frac{20 \sin 60^\circ}{10} = \sqrt{3} \text{ s}$$

Introductory Exercise 4.2

1. Time of flight

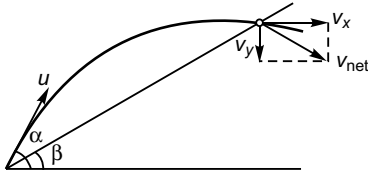

$$\begin{aligned} \alpha &= 60^\circ \\ \beta &= 30^\circ \\ u &= 10 \text{ m/s}^2 \\ g &= 10 \text{ m/s}^2 \end{aligned}$$

$$\begin{aligned} T &= \frac{2u \sin(\alpha - \beta)}{g \cos \beta} \\ &= \frac{(2 \times 10 \sin(60^\circ - 30^\circ))}{10 \cos 30^\circ} \\ &= \frac{2}{\sqrt{3}} \text{ s} \end{aligned}$$

Using,

$$v = u + at$$

$$\begin{aligned} v_x &= u_x = u \cos 60^\circ \\ &= 10 \times \frac{1}{2} = 5 \text{ m/s} \end{aligned}$$

$$\begin{aligned} v_y &= u_y + (-g)T \\ &= u \sin 60^\circ - gT \\ &= 10 \frac{\sqrt{3}}{2} - 10 \frac{2}{\sqrt{3}} \\ &= 10 \left(\frac{3 - 4}{2\sqrt{3}} \right) \\ &= -\frac{5}{\sqrt{3}} \text{ m/s} \end{aligned}$$

$$\begin{aligned} v_{\text{net}} &= \sqrt{v_x^2 + v_y^2} \\ &= \sqrt{5^2 + \left(\frac{-5}{\sqrt{3}}\right)^2} \\ &= 5\sqrt{1 + \frac{1}{3}} \\ &= \frac{10}{\sqrt{3}} \text{ m/s} \end{aligned}$$

2. Component of velocity perpendicular to plane

$$\begin{aligned} &= v_{\text{net}} \cos \beta \\ &= \frac{10}{\sqrt{3}} \times \cos 30^\circ \end{aligned}$$

$$\begin{aligned} &= \frac{10}{\sqrt{3}} \times \frac{\sqrt{3}}{2} \\ &= 5 \text{ m/s} \end{aligned}$$

3. Let the particle collide at time t .

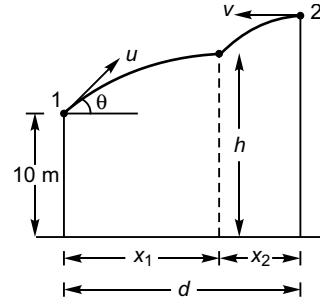

$$x_1 = (u \cos \theta) t$$

and

$$x_2 = vt$$

\therefore

$$d = x_2 - x_1$$

$$= (v + u \cos \theta) t$$

$$= [10 + 10\sqrt{2} \cos 45^\circ] t = 20t$$

Using equation, $s = ut + \frac{1}{2}at^2$

For vertical motion of particle 1 :

$$h - 10 = (u \sin \theta) t + \frac{1}{2}(-g) t^2$$

$$\text{i.e., } h = 10 + (u \sin \theta) t - \frac{1}{2}gt^2 \quad \dots(i)$$

$$\text{or } h - 10 + 10t - \frac{1}{2}gt^2$$

For the vertical motion of particle 2 :

$$20 - h = \frac{1}{2}gt^2$$

$$\text{i.e., } h = 20 - \frac{1}{2}gt^2 \quad \dots(ii)$$

Comparing Eqs. (i) and (ii),

$$10 + 10t - \frac{1}{2}gt^2 = 20 - \frac{1}{2}gt^2$$

$$\Rightarrow t = 1 \text{ s}$$

$$\therefore d = 20 \text{ m}$$

$$u = 10 \text{ m/s}$$

$$v = 5\sqrt{2} \text{ m/s}$$

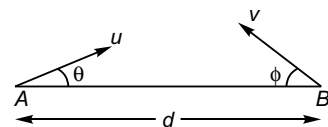

$$\begin{aligned}\theta &= 30^\circ \\ \phi &= 45^\circ \\ d &= 15 \text{ m}\end{aligned}$$

Let the particles meet (or are in the same vertical time t).

$$\begin{aligned}\therefore d &= (u \cos \theta) t + (v \cos \phi) t \\ \Rightarrow 15 &= (10 \cos 30^\circ + 5\sqrt{2} \cos 45^\circ) t \\ \text{or } 15 &= (5\sqrt{3} + 5) t \\ \text{or } t &= \frac{3}{\sqrt{3} + 1} \text{ s} \\ &= 1.009 \text{ s}\end{aligned}$$

Now, let us find time of flight of A and B

$$\begin{aligned}T_A &= \frac{2u \sin \theta}{g} \\ &= 1 \text{ s}\end{aligned}$$

As $T_A < t$, particle A will touch ground before the expected time t of collision.

\therefore Ans : NO.

5. For range to be maximum

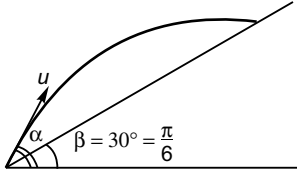

$$\begin{aligned}\alpha &= \frac{\pi}{4} + \frac{\beta}{2} \\ &= \frac{\pi}{4} + \frac{\pi/6}{2} \\ &= \frac{\pi}{3} \\ &= 60^\circ\end{aligned}$$

6. At point A velocity (\vec{v}) of the particle will be parallel to the inclined plane.

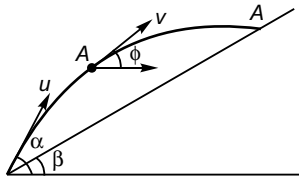

$$\begin{aligned}u &= 40 \text{ m/s} \\ \alpha &= 60^\circ \\ \beta &= 30^\circ \\ g &= 10 \text{ m/s}^2 \\ \therefore \phi &= \beta\end{aligned}$$

$$\begin{aligned}v_x &= u_x = u \cos \alpha \\ v_x &= v \cos \phi = v \cos \beta \\ \text{or } u \cos \alpha &= v \cos \beta \\ \Rightarrow v &= \frac{u \cos \alpha}{\cos \beta} = \frac{40 \cos 60^\circ}{\cos 30^\circ} \\ &= \frac{40 \left(\frac{1}{2}\right)}{\frac{\sqrt{3}}{2}} \\ &= \frac{40}{\sqrt{3}} \text{ m/s}\end{aligned}$$

7. (a) At time t , vertical displacement of A = Vertical displacement of B

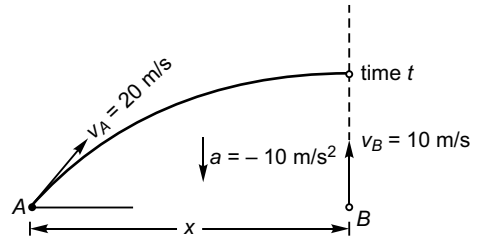

$$\begin{aligned}(v_A \sin \theta) t - \frac{1}{2} g t^2 &= v_B t - \frac{1}{2} g t^2 \\ \text{i.e., } v_A \sin \theta &= v_B \\ \sin \theta &= \frac{v_B}{v_A} \\ &= \frac{10}{20} = \frac{1}{2} \\ \therefore \theta &= 30^\circ\end{aligned}$$

$$\begin{aligned}\text{(b) } x &= (v_A \cos \theta) t \\ &= (20 \cos 30^\circ) \times \frac{1}{2} \\ &= 5\sqrt{3} \text{ m}\end{aligned}$$

AIEEE Corner

Subjective Questions (Level 1)

$$1. (a) R = \frac{u^2 \sin 2\theta}{g} = \frac{(20\sqrt{2})^2 \sin 90^\circ}{10} = 80 \text{ m}$$

$$H = \frac{u^2 \sin^2 \theta}{2g} = \frac{(20\sqrt{2})^2 \sin^2 45^\circ}{10} = 40 \text{ m}$$

$$T = \frac{2u \sin \theta}{g} = \frac{2(20\sqrt{2}) \sin 45^\circ}{10} = 4 \text{ s}$$

$$(b) \vec{u} = (20\hat{i} + 20\hat{j}) \text{ m/s and } \vec{a} = -10\hat{j} \text{ m/s}^2$$

$$-\vec{v} = \vec{u} + \vec{a} t$$

$$= (20\hat{i} + 20\hat{j}) + (-10\hat{j}) 1 \text{ (at } t = 1 \text{ s)}$$

$$= (20\hat{i} - 10\hat{j}) \text{ m/s}$$

(c) Time of flight

$$T = \frac{2u \sin \theta}{g} = \frac{2 \times 20\sqrt{2} \times \left(\frac{1}{\sqrt{2}}\right)}{10} = 4 \text{ s}$$

(c) ∴ Velocity of particle at the time of collision with ground.

$$= (20\hat{i} + 20\hat{j}) + (-10\hat{j}) 4 = (20\hat{i} - 20\hat{j}) \text{ m/s}$$

$$2. (a) s = ut + \frac{1}{2} at^2$$

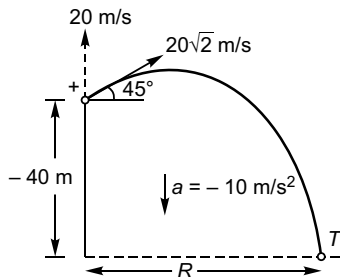

$$\therefore (-40) = (+20) T + \frac{1}{2} (-10) T^2$$

$$\text{or } 5T^2 - 20T - 40 = 0$$

$$\text{or } T^2 - 4T - 8 = 0$$

$$\therefore T = \frac{-(-4) + \sqrt{(-4)^2 - 4(1)(-8)}}{2(1)}$$

Leaving -ive sign which is not positive.

$$= \frac{4 + \sqrt{48}}{2} = \frac{4 + 4\sqrt{3}}{2}$$

$$= (2 + 2\sqrt{3}) \text{ s}$$

$$= 5.46 \text{ s}$$

$$R = 20 \times 5.46 = 109.2 \text{ m}$$

$$(b) s = ut + \frac{1}{2} at^2$$

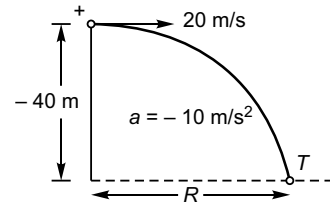

$$(-40) = 0 \times T + \frac{1}{2} (-10) T^2$$

$$\Rightarrow T = 2\sqrt{2} \text{ s}$$

$$= 2.83 \text{ s}$$

$$R = 2.83 \times 20$$

$$= 56.6 \text{ m}$$

$$(c) s = ut + \frac{1}{2} at^2$$

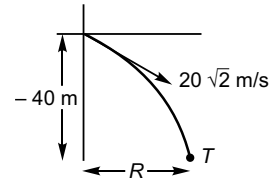

$$(-40) = (-20) T + \frac{1}{2} (-10) T^2$$

$$\text{or } 5T^2 + 20T - 40 = 0$$

$$\text{or } T^2 + 4T - 8 = 0$$

$$\therefore T = \frac{-4 + \sqrt{(4)^2 - 4(1)(-8)}}{2(1)}$$

$$= \frac{-4 + 4\sqrt{3}}{2} = -2 + 2\sqrt{3} = 1.46 \text{ s}$$

$$\begin{aligned} \therefore R &= 20 \times 1.46 \\ &= 29.2 \text{ m} \end{aligned}$$

3. (a) Change in velocity (v_c)
 = Change in vertical velocity
 (as horizontal velocity does not change).
 = $(u \sin \theta - gt) - (u \sin \theta)$
 = $-gt$
 = $-(10 \times 3) \text{ m/s}$
 = -30 m/s
 = 30 m/s (downward)

(b) $\vec{u} = (20\hat{i} + 20\hat{j}) \text{ m/s}$

$$\vec{a} = -10\hat{j} \text{ m/s}^2$$

\therefore Displacement at time $t = (3 \text{ s})$
 = $\vec{u}t + \frac{1}{2}\vec{a}t^2$
 = $(20\hat{i} + 20\hat{j})3 + \frac{1}{2}(-10\hat{j})3^2$
 = $60\hat{i} + 60\hat{j} - 45\hat{j}$
 = $60\hat{i} + 15\hat{j}$

$$\begin{aligned} \therefore \vec{v}_{av} &= \frac{60\hat{i} + 15\hat{j}}{3} \\ &= 20\hat{i} + 5\hat{j} \end{aligned}$$

$$\begin{aligned} \Rightarrow |\vec{v}_{av}| &= \sqrt{(20)^2 + (5)^2} \\ &= \sqrt{425} \\ &= 20.6 \text{ m/s} \end{aligned}$$

4. $R + vT = 50$

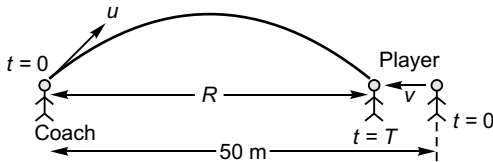

$$\begin{aligned} \Rightarrow vT &= 50 - \frac{u^2 \sin^2 \theta}{g} \\ v \times \frac{2u \sin \theta}{g} &= 50 - \frac{(20)^2}{10} \\ v \times \left(\frac{2 \times 20 \times \sin 45^\circ}{10} \right) &= 10 \end{aligned}$$

$$\begin{aligned} \therefore v &= \frac{100}{40 \times \frac{1}{\sqrt{2}}} \\ &= \frac{5}{\sqrt{2}} \text{ m/s} \end{aligned}$$

5. Horizontal component of velocity at $P =$ Horizontal component of velocity at O

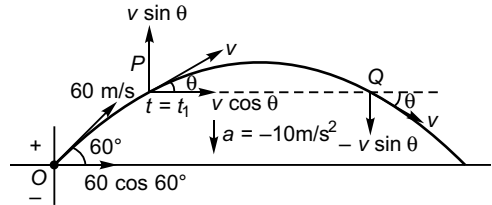

$$\begin{aligned} \therefore v \cos \theta &= 60 \cos 60^\circ \\ \Rightarrow v \cos 45^\circ &= 60 \cos 60^\circ \\ \Rightarrow v &= \frac{60 \cos 60^\circ}{\cos 45^\circ} \\ &= 30\sqrt{2} \text{ m/s} \end{aligned}$$

For point P :

$$\begin{aligned} v \sin 45^\circ &= 60 \sin 60^\circ + (-10)t_1 \\ \text{or } 30 &= 60 \frac{\sqrt{3}}{2} - 10t_1 \\ t_1 &= 3(\sqrt{3} - 1) \\ &= 2.20 \text{ s} \end{aligned}$$

For point Q :

$$\begin{aligned} -v \sin 45^\circ &= 60 \sin 60^\circ + (-10)t_2 \\ \therefore t_2 &= 3(\sqrt{3} + 1) \\ &= 8.20 \text{ s} \end{aligned}$$

6. $Y = bx - cx^2$

Differentiating above equation w.r.t. time t

$$\therefore \frac{dy}{dt} = b \frac{dx}{dt} - 2cx \frac{dx}{dt} \quad \dots(i)$$

$$\Rightarrow \frac{dy}{dt} = b \frac{dx}{dt} \quad (\text{at } x = 0)$$

$$\begin{aligned} v &= \sqrt{\left(\frac{dx}{dt}\right)^2 + \left(\frac{dy}{dt}\right)^2} \\ &= \sqrt{\left(\frac{dx}{dt}\right)^2 + b^2\left(\frac{dx}{dt}\right)^2} \\ &= \sqrt{1 + b^2} \frac{dx}{dt} \quad \dots(ii) \end{aligned}$$

Differentiating Eq. (i) w.r.t. time t

$$\frac{d^2 y}{dt^2} = b \cdot \frac{d^2 x}{dt^2} - 2c \left(\frac{dx}{dt} \right)^2 - 2cx \frac{d^2 x}{dt^2} \dots \text{(iii)}$$

Acceleration of particle

$$-a = \sqrt{\left(\frac{d^2 x}{dt^2} \right)^2 + \left(\frac{d^2 y}{dt^2} \right)^2}$$

$$\therefore \frac{d^2 x}{dt^2} = 0$$

Substituting $\frac{d^2 x}{dt^2} = 0$ and $\frac{d^2 y}{dt^2} = -a$ in Eq. (iii)

$$-a = -2c \left(\frac{dx}{dt} \right)^2$$

i.e.,

$$\frac{dx}{dt} = \sqrt{\frac{a}{2c}}$$

Substituting above value of $\frac{dx}{dt}$ in Eq. (ii)

$$v = \sqrt{\frac{a}{2c} (1 + b^2)}$$

7. (a) Velocity at point A = $7.6 \hat{i} + 6.1 \hat{j}$

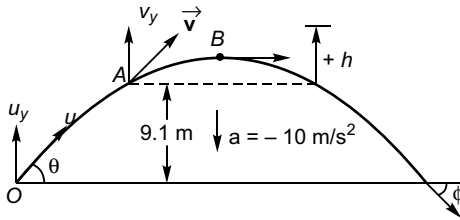

\therefore Initial vertical velocity at A = $6.1 \hat{j}$ m/s.

Final vertical velocity at B (highest point) = 0 m/s

Using $v^2 = u^2 + 2as$ (Between A and B)

$$0^2 = (6.1)^2 + 2(-10)(+h)$$

$$\Rightarrow h = \frac{(6.1)^2}{20} = 1.86 \text{ m}$$

\therefore Maximum height attained by ball

$$= 9.1 + 1.86 = 10.96 \text{ m}$$

(b) Let magnitude of vertical velocity at O (point of projection) = u_y

Using $v^2 = u^2 + 2as$ (Between O and A)

$$\begin{aligned} (6.1)^2 &= u_y^2 + 2(-10)(9.1) \\ \Rightarrow u_y &= \sqrt{37.21 + 182} \\ &= 14.8 \end{aligned}$$

Angle of projection

$$\begin{aligned} \theta &= \tan^{-1} \left(\frac{u_y}{u_x} \right) \\ &= \tan^{-1} \left(\frac{14.8}{7.6} \right) \\ &= \tan^{-1} (1.95) \\ &= 62.82^\circ \end{aligned}$$

$$\begin{aligned} \text{Range} &= \frac{u^2 \sin 2\theta}{g} \\ &= \frac{(u_x^2 + u_y^2) \sin 2\theta}{g} \\ &= \frac{(7.6^2 + 14.8^2) \sin 125.64^\circ}{g} \\ &= \frac{[(7.6)^2 + (14.8)^2] \sin 125.64^\circ}{10} \\ &= 22.5 \text{ m} \end{aligned}$$

(c) Magnitude of velocity just before the ball hits ground

$$\begin{aligned} &= [(-u_y)^2 + (u_x)^2]^{\frac{1}{2}} \\ &= [(-14.8)^2 + (6.1)^2]^{\frac{1}{2}} \quad [u_x = v_x] \\ &= 16 \text{ ms}^{-1} \end{aligned}$$

$$\begin{aligned} \text{(d) } \phi &= \theta = \tan^{-1} \left(\frac{u_y}{u_x} \right) \\ &= \tan^{-1} \left(\frac{14.8}{7.6} \right) \\ &= \tan^{-1} (1.95) \end{aligned}$$

8. As initial vertical velocities of both particles will be zero and both fall under same acceleration (g), at anytime t , the vertical displacement of both will be same

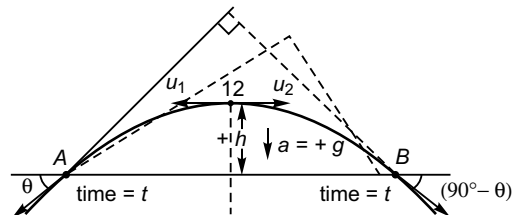

i.e., both will always remain in the same horizontal line as shown in figure.

At time t :

$$\begin{aligned} \text{Vertical velocity of A} &= \text{Vertical velocity of B} \\ &= 0 + (+g)t \\ &= gt \end{aligned}$$

At A :

$$\tan \theta = \frac{\text{Vertical velocity of particle 1}}{\text{Horizontal velocity of particle 1}}$$

$$\text{or } \tan \theta = \frac{gt}{u_1} \quad \dots(i)$$

At B :

$$\tan (90^\circ - \theta) = \frac{\text{Vertical velocity of particle 2}}{\text{Horizontal velocity of particle 2}}$$

$$\text{or } \cos \theta = \frac{gt}{u_2} \quad \dots(ii)$$

Multiplying Eq. (i) by Eq. (ii),

$$1 = \frac{gt}{u_1} \times \frac{gt}{u_2}$$

$$\therefore t = \frac{\sqrt{u_1 u_2}}{g}$$

Distance between A and B

$$\begin{aligned} &= R_1 + R_2 \\ &= u_1 t + u_2 t \\ &= (u_1 + u_2) t \\ &= (u_1 + u_2) \frac{\sqrt{u_1 u_2}}{g} \\ &= \frac{7\sqrt{2}}{9.8} \\ &= 2.47 \text{ m} \end{aligned}$$

$$9. Y = x \left(1 - \frac{x}{R}\right) = \tan \alpha$$

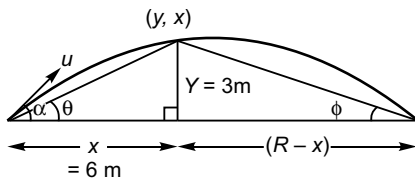

$$\frac{YR}{x(R-x)} = \tan \alpha$$

$$\text{or } \frac{Y}{x} + \frac{y}{R-x} = \tan \alpha$$

$$\text{or } \tan \theta + \tan \phi = \tan \alpha$$

(Students to remember this formula)

$$\Rightarrow \tan \alpha = \frac{3}{6} + \frac{3}{12} = \frac{9}{12}$$

$$\Rightarrow \alpha = \tan^{-1} \left(\frac{3}{4} \right)$$

10. On the trajectory there be two points P and Q at height h from ground.

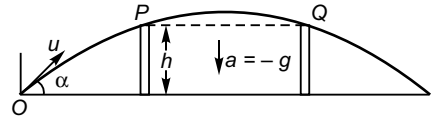

If particle takes t time to reach point A (*i.e.*, vertical displacement of $+h$)

$$(+h) = (u \sin \alpha) t + \frac{1}{2}(-g) t^2$$

$$\text{or } gt^2 - 2(u \sin \alpha) t + 2h = 0 \quad \dots(i)$$

The above equation is quadratic in t . Two values of t will satisfy Eq. (i). One having lower value will be time ($=t_1$) to reach point P while the higher value will be the time ($=t_2$) to reach point Q.

\therefore Time to reach point Q from point P

$$= t_2 - t_1$$

$$= \sqrt{(t_2 + t_1)^2 - 4t_1 t_2}$$

$$= \sqrt{\left(\frac{2u \sin \alpha}{g}\right)^2 - 4\left(\frac{2h}{g}\right)}$$

[Using Eq. (i)]

$$= \frac{4u^2 \sin^2 \alpha - 2gh}{g}$$

$$\text{or } (t_2 - t_1) = \frac{\sqrt{16gh \sin^2 \alpha - 8gh}}{g}$$

$$(\because u = 2\sqrt{gh})$$

Distance between P and Q :

$$2h = (u \cos \alpha) (t_2 - t_1)$$

$$\therefore 4h^2 = u^2 \cos^2 \alpha (t_2 - t_1)^2$$

$$\text{or } 4h^2 = (4gh) \cos^2 \alpha \left(\frac{16gh \sin^2 \alpha - 8gh}{g^2} \right)$$

$$\begin{aligned}
 \text{or} \quad & 1 = \cos^2 (16 \sin^2 \alpha - 8) \\
 \text{or} \quad & 1 = \cos^2 \alpha [16(1 - \cos^2 \alpha) - 8] \\
 \text{or} \quad & 1 = \cos^2 \alpha [8 - 16 \cos^2 \alpha] \\
 \text{or} \quad & 16 \cos^4 \alpha - 8 \cos^2 \alpha + 1 = 0 \\
 \Rightarrow \quad & (4 \cos^2 \alpha - 1)^2 = 0 \\
 \Rightarrow \quad & 4 \cos^2 \alpha = \frac{1}{4} \\
 & \cos \alpha = \frac{1}{2} \\
 & \cos \alpha = 60^\circ
 \end{aligned}$$

($\cos \alpha = -\frac{1}{2}$ being not possible).

$$\begin{aligned}
 \therefore (t_2 - t_1) &= \sqrt{\frac{16gh \sin^2 60^\circ - 2gh}{g^2}} \\
 &= 2 \sqrt{\frac{h}{g}} \quad \text{(Proved)}
 \end{aligned}$$

11. Initial vertical velocity = $u \sin \alpha$

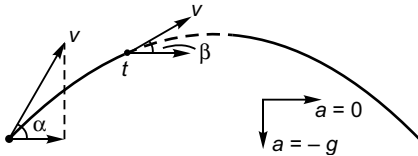

At time t vertical velocity = $v \sin \beta$
 $\therefore v \sin \beta = u \sin \alpha = (-g)t \quad \dots(i)$

Now, as horizontal acceleration will be zero.

$$v \cos \beta = u \cos \alpha$$

Thus, Eq. (i) becomes

$$\left(\frac{u \cos \alpha}{\cos \beta} \right) \sin \beta = u \sin \alpha - gt$$

or $u \sin \alpha \cos \beta - u \cos \alpha \sin \beta = gt \cos \beta$

or $u = \frac{gt \cos \beta}{\sin(\alpha - \beta)}$

12. $R - a = \frac{u^2 \sin 2\alpha}{g}$

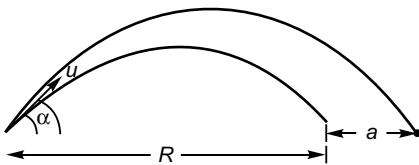

i.e., $bR - ab = \frac{bu^2 \sin 2\alpha}{g} \quad \dots(i)$

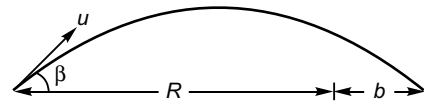

$$R + b = \frac{u^2 \sin 2\beta}{g}$$

i.e., $aR + ab = \frac{au^2 \sin 2\beta}{g} \quad \dots(ii)$

Adding Eqs. (i) and (ii), we have

$$bR + aR = u^2 \left(\frac{b \sin 2\alpha + a \sin 2\beta}{g} \right)$$

or $R = u^2 \frac{(b \sin 2\alpha + a \sin 2\beta)}{(a + b)g}$

$$\frac{u^2 \sin 2\theta}{g} = u^2 \frac{(b \sin 2\alpha + a \sin 2\beta)}{(a + b)g}$$

$$\Rightarrow \theta = \frac{1}{2} \sin^{-1} \left[\frac{b \sin 2\alpha + a \sin 2\beta}{a + b} \right]$$

(Proved.)

13. $R_1 = v_1 \sqrt{\frac{2h}{g}}$

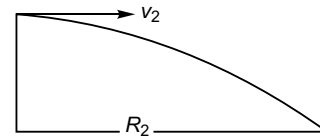
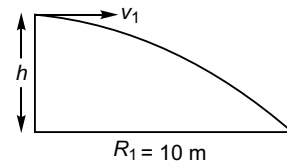

i.e., $h = \frac{1}{2} \left(\frac{R_1 g}{v_1} \right)^2$
 $= \frac{1}{2} \left(\frac{10 \times 9.8}{5} \right)^2$
 $= 19.6 \text{ m}$

$\therefore T = \sqrt{\frac{2h}{g}}$
 $= \sqrt{\frac{2 \times 19.6}{9.8}}$
 $= 2 \text{ s}$
 $R_2 = v_2 \cdot T = 7.5 \times 2$
 $= 15 \text{ m}$

14. Vertical velocity of balloon (+ bag)

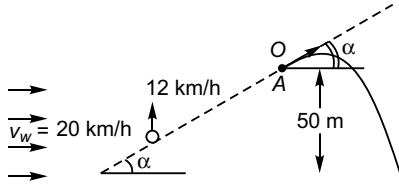

$$= 12 \times \frac{5}{18} \text{ m/s}$$

$$= \frac{10}{3} \text{ m/s}$$

Horizontal velocity of balloon (+ bag)

$$= \text{Wind velocity} = 20 \text{ km/h} = 20 \times \frac{5}{18} \text{ m/s}$$

$$= \frac{50}{9} \text{ m/s}$$

$$= 5.55 \text{ m/s}$$

$$\therefore \tan \alpha = \frac{12}{20}, \text{ i.e., } \sin \alpha = 0.51$$

Bag is released at point A.

Let t be time, the bag takes from A to reach ground.

$$\text{Using, } s = ut + \frac{1}{2}at^2$$

$$(-50) = \left(\frac{10}{3} \sin \alpha\right)t + \frac{1}{2}(-g)t^2$$

$$\text{i.e., } 5t^2 - 1.7t - 50 = 0$$

$$\therefore t = \frac{1.7 + \sqrt{(-1.7)^2 - 4 \times 5 \times (-50)}}{2 \times 5}$$

$$= 3.37 \text{ s}$$

Vertical velocity of bag when it strikes ground

$$v_B = -\frac{10}{3} + (10)(3.37)$$

$$= 37.03 \text{ m/s}$$

$$v_w = 5.55 \text{ m/s}$$

\therefore Velocity of bag with which it strikes ground

$$v_{\text{net}} = \sqrt{v_B^2 + v_w^2}$$

$$= 37.44 \text{ m/s}$$

15. $T = \frac{2u \sin(\alpha - \beta)}{g \cos \beta}$

$$= \frac{2 \times 20\sqrt{2} \times \sin(45^\circ - 30^\circ)}{10 \cos 30^\circ}$$

$$= 1.69 \text{ s}$$

$$R = \frac{2u^2 \sin(\alpha - \beta) \cos \alpha}{g \cos^2 \beta}$$

$$= \frac{2 \times (20\sqrt{2})^2 \times \sin 15^\circ \times \cos 45^\circ}{10 \cos^2 30^\circ}$$

$$= 39 \text{ m}$$

16. $T = \frac{2u \sin(\alpha + \beta)}{g \cos \beta}$

$$= \frac{2 \times 20\sqrt{2} \times \sin(45^\circ + 30^\circ)}{10 \cos 30^\circ}$$

$$= 6.31 \text{ s}$$

$$R = \frac{u^2}{g \cos^2 \beta} [\sin(2\alpha + \beta) + \sin \beta]$$

$$= \frac{(20\sqrt{2})^2}{10 \cos^2 30^\circ} [\sin(90^\circ + 30^\circ) + \sin 30^\circ]$$

$$= 145.71 \text{ m}$$

17. $T = \frac{2u \sin(\alpha + \beta)}{g \cos \beta}$

$$= \frac{2u \sin \beta}{g \cos \beta} \quad (\because \alpha = 0^\circ)$$

$$= \frac{2u}{g} \tan \beta$$

$$= \frac{2 \times 20}{10} \tan 30^\circ$$

$$= 2.31 \text{ s}$$

$$R = \frac{u^2}{g \cos^2 \beta} [\sin(2\alpha + \beta) + \sin \beta]$$

$$= \frac{u^2 (2 \sin \beta)}{g \cos^2 \beta} \quad [\text{as } \alpha = 0^\circ]$$

$$= \frac{uT}{\cos \beta} = \frac{20 \times 2.31}{\cos 30^\circ}$$

$$= 53.33 \text{ m}$$

18. $R = \frac{u^2}{g \cos^2 \beta} [\sin(2\alpha + \beta) + \sin \beta]$

$$= \frac{u^2}{g \cos^2 \beta} [\sin\{2(\alpha + \beta) - \beta\} + \sin \beta]$$

$$= \frac{u^2}{g \cos^2 \theta} [\sin(\pi - \theta) + \sin \theta]$$

$$[\because (\alpha + \beta) = \frac{\pi}{2}]$$

or $R = \frac{2u^2}{g} \tan \theta \sec \theta$

Projectile Motion 61

19. (a) Acceleration of particle 1 w.r.t. that of particle 2

$$= (-g) - (-g) \\ = 0$$

- (b) Initial velocity of 1st particle = $20\hat{j}$ m/s

Initial velocity of 2nd particle

$$= (20\sqrt{2} \cos 45^\circ \hat{i} + 20\sqrt{2} \sin 45^\circ \hat{j}) \text{ m/s} \\ = (20\hat{i} + 20\hat{j}) \text{ m/s}$$

\therefore Initial velocity of 1st particle w.r.t. that of 2nd particle

$$= [(20\hat{j}) - (20\hat{i} + 20\hat{j})] \text{ m/s} \\ = -20\hat{i} \text{ m/s} \\ = 20 \text{ m/s (downward)}$$

- (c) Horizontal velocity of 1st particle = 0 m/s

Horizontal velocity of 2nd particle

$$= 20\hat{i} \text{ m/s}$$

\therefore Horizontal velocity of 1st particle w.r.t. that of 2nd particle

$$= 0 - (20\hat{i}) \\ = -20\hat{i} \text{ m/s}$$

Relative displacement of 1st particle w.r.t. 2nd particle at $t = 2$ s

$$= -20\hat{i} \times 2 \\ = -40\hat{i} \text{ m/s}$$

\therefore Distance between the particles at $t = 2$ s

$$= 40 \text{ m}$$

20. (a) As observed by passenger

Vertical acceleration of stone

$$= g - 0 = g$$

Horizontal velocity of stone

$$= v - v = 0$$

\therefore Path of the stone will be a straight line (downwards).

- (b) As observed by man standing on ground

Vertical acceleration of stone = g

Horizontal velocity of stone = v

\therefore Path of the stone will be parabolic.

21. (a) $g_{\text{eff}} = g - (-a)$

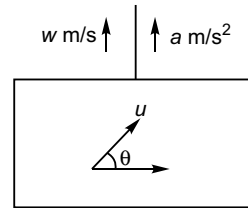

$$= g + a$$

$$= 10 + 1$$

$$= 11 \text{ m/s}^2$$

$$T = \frac{2u \sin \theta}{g_{\text{eff}}}$$

$$= \frac{2 \times 2 \times \sin 30^\circ}{11}$$

$$= 0.18 \text{ s}$$

- (b) Dotted path [(in lift) acceleration upwards]



Full line path [In lift at rest or moving with constant velocity upwards or downwards].

- (c) If lift is moving downward with acceleration g .

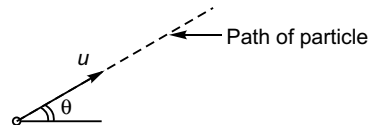

$$g_{\text{eff}} = g - g = 0$$

22. Horizontal motion :

$$x_1 = u_1 \cos \theta_1 \text{ and } x_2 = u_2 \cos \theta$$

$$\therefore u_1 \cos \theta_1 + u_2 \cos \theta_2 = 20 \quad \dots(i)$$

62 | Mechanics-1

Vertical motion :

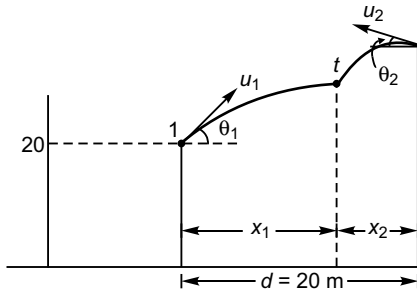

$$20 + (u_1 \sin \theta_1) t + \frac{1}{2}(-g) t^2 = 30$$

$$+ (u_2 \sin \theta_2) t + \frac{1}{2}(-g) t^2$$

or $(u_1 \sin \theta_1 - u_2 \sin \theta_2) t = 10 \quad \dots(ii)$

Objective Questions (Level 1)

1. $\vec{v} = 3 \hat{i} + 4 \hat{j}$ and $\vec{F} = 4 \hat{i} - 3 \hat{j}$

$$\vec{v} \cdot \vec{F} = (3 \hat{i} + 4 \hat{j}) \cdot (4 \hat{i} - 3 \hat{j})$$

$$= 12 - 12 = 0$$

$\therefore \vec{F} \perp \vec{v}$

Path of the particle is circular.

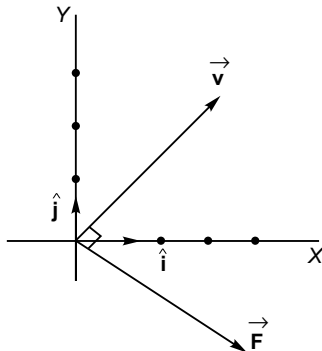

Option (c) is correct.

2. Projectile motion is uniformly accelerated everywhere even at the highest point.

Option (a) correct.

Option (b) incorrect.

At the highest point acceleration is perpendicular to velocity.

Option (c) incorrect.

3. For range to be maximum

$$\theta = 45^\circ$$

i.e., $\frac{u_x}{u} = \cos 45^\circ = \frac{1}{\sqrt{2}}$

or $v_x = \frac{u}{\sqrt{2}} \quad (\because v_x = u_x)$

$$= \frac{20}{\sqrt{2}}$$

$$= 14.14 \text{ m/s}$$

$$= 14 \text{ m/s (approx)}$$

Option (b) is correct.

4. H (maximum height) = $\frac{u^2 \sin^2 \alpha}{2g}$

$$\therefore H_1 = \frac{u^2 \sin^2 \theta}{2g} \text{ and } H_2 = \frac{u^2 \sin^2 (90^\circ - \theta)}{g}$$

$$= \frac{u^2 \cos^2 \theta}{g}$$

Thus, $\frac{H_1}{H_2} = \frac{\sin^2 \theta}{\cos^2 \theta}$

Option (c) is correct.

5. Equation to trajectory is

$$Y = x \tan \theta - \frac{1}{2} \frac{g x^2}{u^2 \cos^2 \theta \sin \theta}$$

$$Y = x \tan \theta - \frac{x^2}{R}$$

$$\text{Area} = \int_0^R Y dx$$

$$= \int_0^R \left(x \tan \theta - \frac{x^2}{R} \right) dx$$

$$A = \left[\frac{x^2}{2} \tan \theta - \frac{x^3}{3R} \right]_0^R$$

$$= \frac{R^2}{2} \tan \theta - \frac{R^3}{3}$$

$$= R^2 \left[\frac{\tan \theta}{2} - \frac{1}{3} \right]$$

$$\begin{aligned}
 &= \frac{4u_0^4 \sin^2 \theta \cos^2 \theta \left[\frac{\tan \theta}{2} - \frac{1}{3} \right]}{g^2} \\
 &= \frac{4u_0^4}{g^2} \left[\frac{\sin^3 \theta \cos \theta}{2} - \frac{\sin^2 \theta \cos^2 \theta}{3} \right] \\
 &= \frac{2u_0^4}{3g^2} [3 \sin^2 \theta \cos \theta - 2 \sin^2 \theta \cos^2 \theta]
 \end{aligned}$$

6. $v \cos \phi = u \cos \theta$

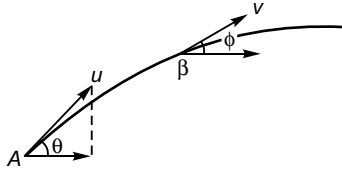

or $v = \frac{u \cos 60^\circ}{\cos 30^\circ}$

or $v = \frac{u}{\sqrt{3}}$

KE at B = $\frac{1}{2} mv^2$

$$\begin{aligned}
 &= \frac{1}{2} m \cdot \frac{u^2}{3} \\
 &= \frac{K}{3} \quad \left(\because \frac{1}{2} mu^2 = K \right)
 \end{aligned}$$

\therefore Option (b) is correct.

7. $\frac{u^2 \sin 2\theta}{g} = \frac{1}{2} \left(\frac{u^2}{g} \right)$

or $\sin 2\theta = \frac{1}{2}$

or $2\theta = 30^\circ$

$\therefore \theta = 15^\circ$

Option (a) is correct.

8. $T_1 = \frac{2u \sin \theta}{g}$

$\therefore T_2 = \frac{2u \sin (90^\circ - \theta)}{g}$

$$= \frac{2u \cos \theta}{g}$$

Thus, $T_1 T_2 = \frac{2}{g} \frac{2u^2 \sin \theta \cos \theta}{g}$

or $T_1 T_2 = \frac{2R}{g}$

$\Rightarrow R = \frac{1}{2} g T_1 T_2$

Option (d) is correct.

9. $R_{\max} = 1.6 \text{ m}$

$$\frac{u^2}{g} = 1.6$$

$\Rightarrow u = 4 \text{ m/s}$

$\therefore T = \frac{2u \sin 45^\circ}{g}$

$$= \frac{4\sqrt{2}}{10}$$

Number of jumps = $\frac{10\sqrt{2}}{T} = \frac{10\sqrt{2}}{4\sqrt{2}/10}$

$$= 25$$

\therefore Grass hopper would go = $25 \times 1.6 \text{ m i.e., } 40 \text{ m.}$

Option (d) is correct.

10. |Av. velocity| = $\frac{|\text{Displacement}|}{\text{time}}$

$$\begin{aligned}
 &= \frac{1}{T/2} \sqrt{\left(\frac{R}{2}\right)^2 + H^2} \\
 &= \frac{1}{u \sin \theta} \sqrt{\left(\frac{u^2 \sin \theta \cos \theta}{g}\right)^2 + \left(\frac{u^2 \sin^2 \theta}{2g}\right)^2} \\
 &= u \sqrt{\cos^2 \theta + \frac{\sin^2 \theta}{4}} \\
 &= \frac{u}{2} \sqrt{1 + 3 \cos^2 \theta}
 \end{aligned}$$

Option (b) is correct.

11. $d^2 = R^2 + u^2 T^2$

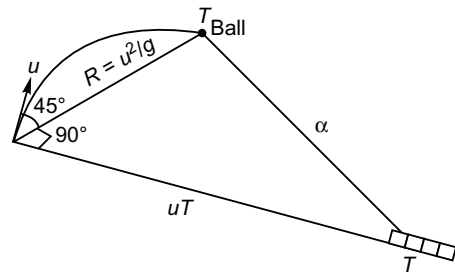

$$\begin{aligned}
 &= \left(\frac{u^2}{g}\right)^2 + u^2 \left(\frac{2u \sin 45^\circ}{g}\right)^2 \\
 &= \frac{u^4}{g^2} + \frac{2u^4}{g^2} \\
 &= \frac{3u^4}{g^2}
 \end{aligned}$$

64 | Mechanics-1

$$\therefore d = \frac{u^2}{g} \sqrt{3} = \frac{30^2}{10} \sqrt{3} = 90\sqrt{3} \text{ m}$$

Option (b) is correct.

12. At maximum height

$$\frac{dy}{dt} = 0$$

$$\text{i.e., } \frac{d}{dt}(10t - t^2) = 0$$

$$\text{or } 10 - 2t = 0$$

$$\text{or } t = 5 \text{ s}$$

$$\therefore \text{Maximum height attained} = 10(5) - 5^2 = 25 \text{ m}$$

Option (d) is correct.

$$13. R = \frac{u^2}{g \cos^2 \beta} [\sin(2\alpha + \beta) + \sin \beta]$$

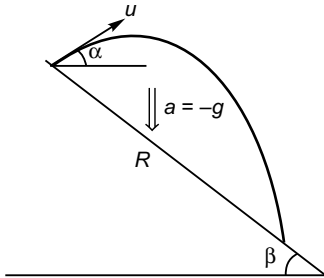

As $\alpha = 0$ (according to question)

$$\begin{aligned} R &= \frac{u^2}{g \cos^2 \beta} [2 \sin \beta] \\ &= \frac{(50)^2 \times 2 \sin 30^\circ}{10 \times \cos^2 30^\circ} \\ &= \frac{1000}{3} \text{ m} \end{aligned}$$

Option (b) is correct.

14. **First particle :**

$$H_{\max} = 102 \text{ m}$$

$$\therefore \frac{u^2 \sin^2 \alpha}{2g} = 102$$

$$\Rightarrow u^2 = \frac{102 \times 2g}{\sin^2 60^\circ} \quad [\text{As } \alpha = \frac{\pi}{3} = 60^\circ]$$

Second particle :

Range of the second particle will be equal to that of particle

$$\text{if, } \frac{u^2 \sin 2\phi}{g} = \frac{u^2 \sin 2\alpha}{g}$$

$$\sin 2\phi = \sin 3\alpha$$

$$2\phi = \pi - 2\alpha$$

$$\text{or } \phi = \frac{\pi}{2} - \alpha$$

$$= \frac{\pi}{2} - \frac{\pi}{3} = \frac{\pi}{6} = 30^\circ$$

\therefore Maximum height attained by second particle

$$\begin{aligned} &= \frac{u^2 \sin^2 \phi}{2g} \\ &= \frac{102 \times 2g}{\sin^2 60^\circ} \times \frac{\sin^2 30^\circ}{2g} \\ &= \frac{102 \times 1/4}{3/4} = 34 \text{ m} \end{aligned}$$

Option (d) is correct.

$$15. s = ut + \frac{1}{2} at^2$$

$$\therefore (-70) = (50 \sin 30^\circ) t + \frac{1}{2} (-10) t^2$$

$$\text{or } 5t^2 - 25t - 70 = 0$$

$$\text{or } t^2 - 5t - 14 = 0$$

$$(t - 7)(t + 2) = 0$$

$$t = 7 \text{ s}$$

(-2 s not possible)

Option (c) is correct.

16. Initial separation

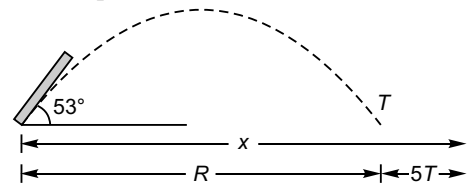

$$x = R + 5T$$

$$= (u \cos \alpha) T + 5T$$

$$= T[(u \cos \alpha) + 5]$$

$$= \frac{2u \sin \alpha}{g} [(u \cos \alpha) + 5]$$

$$= \frac{2 \times 80 \times \frac{4}{5}}{10} \left[\left(80 \times \frac{3}{5} \right) + 5 \right] = 256 \text{ m}$$

Option (d) is correct.

JEE Corner

Assertion and Reason

1. Assertion is wrong while the explanation as given in reason is correct.
 \therefore Option (d) is correct.

2. Assertion and Reason both are correct, both carry the same meaning.
 Option (a) is correct.

3. $H = \frac{u^2 \sin^2 \alpha}{2g}$ [$H =$ maximum height]

$$= \frac{g}{8} \left(\frac{2u \sin \alpha}{g} \right)^2 = \frac{g}{8} T^2$$

i.e., $H \propto T^2$ (Reason)

$\therefore H$ will become four times if T is made two times.

Thus, assertion is correct and also reason is the correct explanation of the assertion.

Option (a) is correct.

4. Reason is correct as $\vec{A} \cdot \vec{B} = 0$ when \vec{A} and \vec{B} are perpendicular to each other.

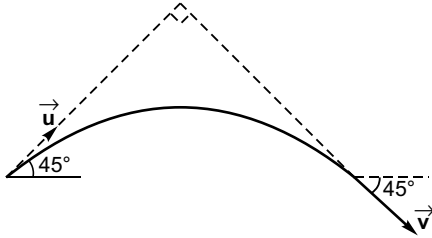

In the case mentioned \vec{v} is perpendicular to \vec{u} only at $t = T$ and not at any time t .

Option (b) is correct.

[Note: \vec{v} will never be perpendicular to \vec{u} if angle of projection is less than 45° .]

5. $x = u_x t + \frac{1}{2} a_x t^2$

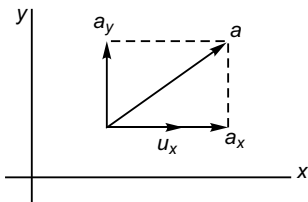

and $y = \frac{1}{2} a_y t^2$

Thus, $x = u_x \sqrt{\frac{2y}{a_y}} + \frac{1}{2} a_x \frac{2y}{a_y}$

or $x = k_1 \sqrt{y} + k_2 y$

or $(x - k_2 y)^2 = k_1^2 y$

or $x^2 + k_2^2 y^2 - 2k_2 y - k_1^2 y = 0$

or $x^2 + k_2^2 y^2 - (2k_2 + k_1^2) y = 0$

6. $\frac{\vec{v}_2 - \vec{v}_1}{t_2 - t_1}$

$$= \frac{(\vec{u} + \vec{a} t_2) - (\vec{u} + \vec{a} t_1)}{t_2 - t_1}$$

$= \vec{a}$ (which is a constant quantity in projectile motion).

\therefore Assertion is correct and the reason for this also correct, as explained.

Thus, option (a) is correct.

7. Let initial velocity of $A = u_A$

Initial velocity of $B = u_B$

B is projected at an angle α with horizontal.

For time (T_A) taken by A to return to the point of projection :

$$(-u_A) = (+u_A) + (-g) T_A$$

$$\Rightarrow T_A = \frac{2u_A}{g} = 4 \text{ (s)}$$

Time taken by B to reach ground

$$T_B = \frac{2u_B \sin \alpha}{g} = 4 \text{ (s)}$$

($\because T_B = T_A$ given)

$$\therefore u_B \sin \alpha = 2g$$

Height attained by B

$$H = \frac{u_B^2 \sin^2 \alpha}{2g}$$

$$= \frac{(2g)^2}{2g}$$

$$= 2g$$

$$= 20 \text{ m}$$

∴ Assertion is correct.

Reason for this incomplete as then T_A will not be equal to T_B .

Thus, option (c) is correct.

8.
$$H = \frac{u_V^2}{2g}$$

∴
$$H_1 : H_2 = 4H : H$$

i.e.,
$$\frac{u_{1V}^2}{2g} : \frac{u_{2V}^2}{2g} = 4 : 1$$

or
$$u_{1V} : u_{2V} = 2 : 1 \quad \dots(i)$$

$$R = \frac{2u_V u_H}{g}$$

For $R_1 = R_2$

$$u_{1V} u_{1H} = u_{2V} u_{2H}$$

$$\frac{u_{1H}}{u_{2H}} = \frac{u_{2V}}{u_{1V}}$$

or
$$\frac{u_{1H}}{u_{2H}} = \frac{1}{2} \quad [\text{Using relation (i)}]$$

∴ Assertion is correct.

Reason is correct as the given relation under heading reason leads to

$$\text{Range} = v_H \times \frac{2v_V}{g}$$

∴ Option (a) is correct.

9. Assertion is incorrect as it is the velocity which would decrease by 10 m/s in the downward direction.

Acceleration is nothing but rate of change of velocity written against reason is correct.

∴ Option (d) is correct.

10. Using law of conservation of mechanical energy

$$\frac{1}{2}mv^2 + mgh = \frac{1}{2}mu^2$$

∴
$$v = \sqrt{u^2 - 2gh}$$

Thus, assertion is correct.

If the particle is projected with vertical component of velocity as u_y , the vertical component of velocity of the particle at height h would be $\sqrt{u_y^2 - 2gh}$ is correct as written against reason but it is not the correct explanation of the assertion as nothing is given regarding the change in the horizontal component of velocity.

Objective Questions (Level 2)

Single Correct Option

1.
$$s = ut + \frac{1}{2}at^2$$

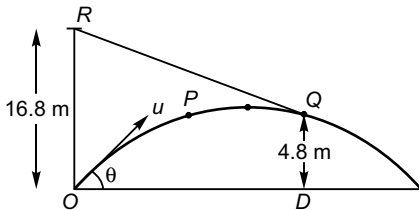

$$= (u \sin \theta) t + \frac{1}{2}(-gt)^2$$

$$= 24 \sin \theta - 7 \times 2$$

For $\theta = 30^\circ$: $s = 4.8 \text{ m}$

Time for attaining maximum height

$$= \frac{u \sin \theta}{g}$$

$$= 1 \text{ s}$$

∴ Above displacement is for point Q.

For $\theta = 90^\circ$: $s = 16.8 \text{ m}$

For $\theta = 30^\circ$: $OD = (u \cos \theta) t$

$$= (20 \cos 30^\circ) 1 \times 2$$

$$= 20.8$$

∴
$$QR = \sqrt{(20.8)^2 + (16.8 - 4.8)^2}$$

$$= 24 \text{ m}$$

Option (c) is correct.

Projectile Motion 67

2. $t = \frac{d}{u}$ also $h = \frac{1}{2}gt^2$

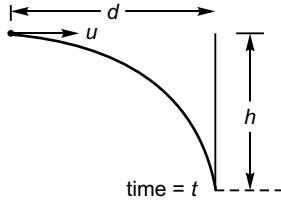

$$\therefore h = \frac{1}{2}g \cdot \frac{d^2}{u^2}$$

$$\Rightarrow d^2 = \frac{2u^2h}{g}$$

Option (b) is correct.

3. $R = \frac{u^2}{g \cos^2 \beta} [\sin(2\alpha + \beta) + \sin \beta]$

Substituting $v = 10 \text{ m/s}$

$$g = 10 \text{ m/s}^2$$

$$\alpha + \beta = 90^\circ$$

and $\beta = 30^\circ$

$$R = \frac{(10)^2}{10 \cos^2 30^\circ} [\sin(90^\circ + 60^\circ) + \sin 30^\circ]$$

$$= \frac{10}{\left(\frac{3}{4}\right)} \left[\frac{1}{2} + \frac{1}{2}\right] = \frac{40}{3} \text{ m}$$

Option (c) is correct.

4. $y = x \tan \theta - \frac{1}{2}g \frac{x^2}{u^2 \sin \theta \cos \theta}$

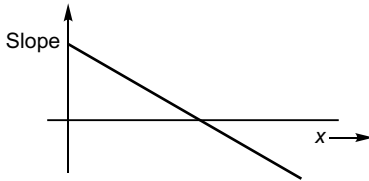

$$\frac{dy}{dx} = \tan \theta - \frac{1}{2} \frac{2x}{u^2 \sin \theta \cos \theta}$$

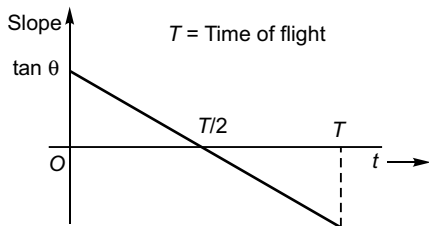

Slope of trajectory = $\tan \theta - \frac{x}{u^2 \sin \theta \cos \theta}$

Substituting $x = (u \cos \theta) t$

$$\frac{dy}{dx} = \tan \theta - \frac{(u \cos \theta) t}{u^2 \sin \theta \cos \theta}$$

$$= \tan \theta - \frac{t}{u \sin \theta}$$

Option (a) is correct.

5. $y = \beta x^2$

$$\therefore \frac{dy}{dt} = \beta \cdot 2x \frac{dx}{dt}$$

and $\frac{d^2y}{dt^2} = 2\beta \left[x \cdot \frac{d^2x}{dt^2} + \left(\frac{dx}{dt} \right)^2 \right]$

or $\alpha = 2\beta \left[x \frac{d^2x}{dt^2} + \left(\frac{dx}{dt} \right)^2 \right]$

Now, as $\frac{d^2x}{dt^2} = 0$

(acceleration being along y -axis only)

$$\frac{dx}{dt} = \sqrt{\frac{\alpha}{2\beta}}$$

Option (d) is correct.

6. As the projectile hits the inclined plane horizontally

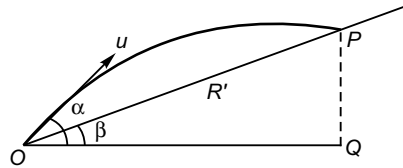

$$PQ = H_{\max} = \frac{u^2 \sin^2 \alpha}{2g}$$

and $OQ = \frac{u^2 \sin \alpha \cos \alpha}{g}$

\therefore Range on inclined plane

$$R' = \sqrt{(PQ)^2 + (OQ)^2}$$

$$= \sqrt{\left(\frac{u^2 \sin^2 \alpha}{2g} \right)^2 + \left(\frac{u^2 \sin \alpha \cos \alpha}{g} \right)^2}$$

$$= \frac{u^2}{g} \sqrt{\frac{\sin^4 \alpha}{4} + \sin^2 \alpha \cos^2 \alpha}$$

$$= \frac{u^2}{g} \sqrt{\frac{1}{4} \left(\frac{\sqrt{3}}{4} \right)^4 + \left(\frac{\sqrt{3}}{2} \right)^2 \left(\frac{1}{2} \right)^2}$$

$$\begin{aligned}
 &= \frac{u^2}{g} \sqrt{\frac{9}{64} + \frac{3}{16}} \\
 &= \frac{u^2 \sqrt{21}}{8g}
 \end{aligned}$$

Option (d) is correct.

7. Let the projectile hits the inclined plane at P at time t

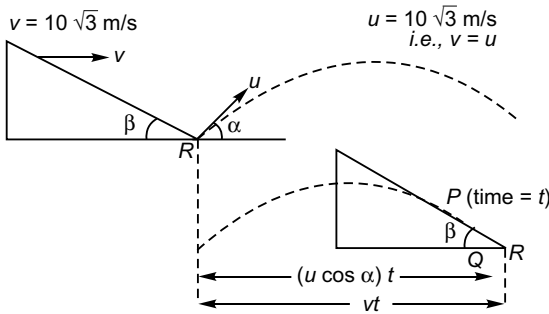

$$PQ = (u \sin \alpha) - \frac{1}{2}gt^2$$

Further, $QR = vt - (u \cos \alpha) t$

and $\tan \beta = \frac{PQ}{QR}$

i.e., $OQ \tan \beta = PQ$

$$t[v - \cos \alpha] \tan \beta = \left[u \sin \alpha - \frac{1}{2}gt \right] t$$

$$\begin{aligned}
 \text{or } 10[1 - \cos 60^\circ] \tan 30^\circ \\
 &= \left[10 \sin 60^\circ - \frac{1}{2} \times 10 \times t \right]
 \end{aligned}$$

$$\text{or } \frac{5}{\sqrt{3}} = 5\sqrt{3} - 5t$$

$$\text{or } t = \sqrt{3} - \frac{1}{\sqrt{3}}$$

$$= \frac{2}{\sqrt{3}} \text{ s}$$

8. $y^2 + 2y + 2 = x$

$$\therefore 2y \frac{dy}{dt} + 2 \frac{dy}{dt} = \frac{dx}{dt}$$

$$\text{or } (2y + 2) \frac{dy}{dt} = \frac{dx}{dt}$$

$$\text{or } \frac{dx}{dt} = 10(y + 1)$$

$$\text{or } \frac{d^2x}{dt^2} = 10 \left(\frac{dy}{dt} \right)$$

$$= 50 \text{ m/s}^2$$

Acceleration of the particle

$$= \frac{d^2x}{dt^2}$$

$$= 50 \text{ m/s}^2 \quad \left[\text{as } \frac{dy}{dt} = \text{constant} \right]$$

9. $\tan \alpha = \tan \theta + \tan \phi$

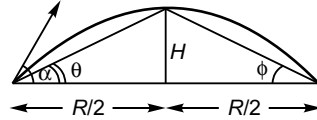

$$= \tan \theta + \tan \theta = 2 \tan \theta$$

$$\therefore \theta = \tan^{-1} \left(\frac{\tan \alpha}{2} \right)$$

Option (c) is correct.

10. At any time t,

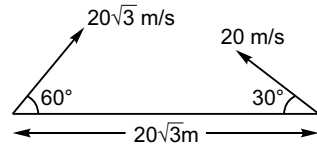

Horizontal distance between particles

$$\begin{aligned}
 x &= 20\sqrt{3} - (10\sqrt{3} + 10\sqrt{3}) t \\
 &= 20\sqrt{3} (1 - t)
 \end{aligned}$$

Vertical distance between particles at time t

$$y = (30 - 10) t = 20 t$$

Distance between particles at time t

$$D = \sqrt{x^2 + y^2}$$

$$\begin{aligned}
 \text{or } D^2 &= [20\sqrt{3}(1 - t)]^2 + [20t]^2 \\
 &= 400[3(1 - t)^2] + 400t^2
 \end{aligned}$$

For D to minimum

$$\frac{dD}{dt} = 0$$

$$3 \times 2(1 - t)(-1) + 2t = 0$$

$$\text{or } 6t - 6 + 2t = 0$$

$$\text{i.e., } t = \frac{3}{4} \text{ s}$$

$$\therefore D_{\min}^2 = 400 \left[3 \left(1 - \frac{3}{4} \right)^2 \right] + 400 \left(\frac{3}{4} \right)^2$$

$$= 75 + 75 \times 3$$

$$\Rightarrow D_{\min} = 10\sqrt{3} \text{ m}$$

Option (b) is correct.

11. Let time of flight = T

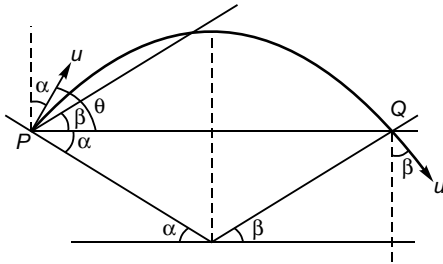

As, horizontal component of the velocity of the particle will not change

$$u \cos(90^\circ - \alpha) = v \cos(90^\circ - \beta)$$

or $u \sin \alpha = v \sin \beta \quad \dots(i)$

Using $v = u + at$ for the horizontal component of velocity

$$(-v \cos \beta) = (+u \cos \alpha) + (-g) T$$

$$\Rightarrow gT = u \cos \alpha + v \cos \beta$$

or $T = \frac{u \cos \alpha + v \cos \beta}{g} \quad \dots(ii)$

Now, as $\alpha = \beta (= 30^\circ)$, $u = v$ from Eq. (i)

More than One Correct Options

1. Two particles projected at angles α and β with same speed ($=u$) will have same range if

$$\alpha + \beta = 90^\circ$$

Option (a) is correct.

$$R = \frac{2u^2 \sin \alpha \cos \alpha}{g}$$

h_1 (maximum height attained by first)

$$= \frac{u^2 \sin^2 \alpha}{2g}$$

h_2 (maximum height attained by second)

$$= \frac{u^2 \sin^2 \beta}{2g}$$

$$\begin{aligned} \therefore \sqrt{h_1 h_2} &= \frac{u^2 \sin \alpha \sin \beta}{2g} \\ &= \frac{u^2 \sin \alpha \sin(90^\circ - \alpha)}{2g} \\ &= \frac{u^2 \sin \alpha \cos \alpha}{2g} = \frac{R}{4} \end{aligned}$$

Option (b) is correct.

Substituting $v = u$ and $\alpha = \beta = 30^\circ$ in Eq. (ii)

$$\begin{aligned} T &= \frac{u \cos 30^\circ + u \cos 30^\circ}{g} \\ &= \frac{2u \cos 30^\circ}{g} \\ &= \frac{u\sqrt{3}}{g} \end{aligned}$$

Option (b) is correct.

12. $PQ = \frac{2u^2 \sin \theta \cos \theta}{g}$

or $2a \cos \alpha = \frac{2u^2 \sin(90^\circ - \alpha) \cos(90^\circ - \alpha)}{g}$

or $a = \frac{u^2 \sin \alpha}{g}$

or $u^2 = 2ag$ (as $\alpha = 30^\circ$)

or $u^2 = 2 \times 4.9 \times 9.8$

or $u = 9.8 \text{ m/s}$

Option (a) is correct.

t_1 (time of flight of first) = $\frac{2u \sin \alpha}{g}$

t_2 (time of flight of second) = $\frac{2u \sin \beta}{g}$

$\therefore \frac{t_1}{t_2} = \frac{\sin \alpha}{\sin \beta} = \frac{\sin \alpha}{\sin(90^\circ - \alpha)} = \tan \alpha$

Option (c) is correct.

Also, $\sqrt{\frac{h_1}{h_2}} = \frac{\sin \alpha}{\sin \beta} = \tan \alpha$

Option (d) is correct.

2. Horizontal displacement in time t (Time of flight)

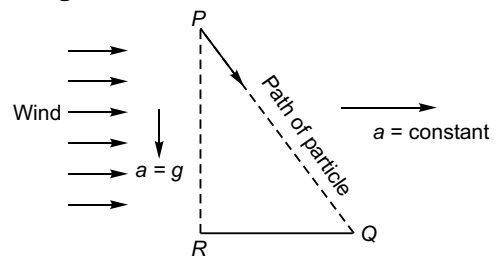

$$x = \frac{1}{2} at^2 \quad \dots(i)$$

70 | Mechanics-1

Vertical displacement in time t

$$y = \frac{1}{2}gt^2 \quad \dots(ii)$$

$$\therefore \frac{y}{x} = \frac{g}{a}$$

or $y = \text{constant } x$ [as a is constant]

Option (a) is correct.

Substituting $y = 49$ m in Eqs. (ii)

$$49 = \frac{1}{2} \times 9.8 \times t^2$$

$$\Rightarrow t = \sqrt{10} = 3.16 \text{ s}$$

$PQ > PR$ ($= 40$ m)

Option (d) is correct.

3. As there will be no change in the horizontal component of the velocity of the particle

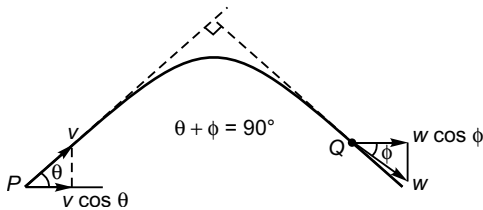

$$w \cos \phi = v \cos \theta$$

or $w \cos (90^\circ - \theta) = v \cos \theta$

or $w \sin \theta = v \cos \theta$

or $w = v \cos \theta$

Option (b) is correct.

Option (a) is incorrect.

Vertical velocity of particle at Q

$$\begin{aligned} &= w \sin \phi \\ &= w \sin (90^\circ - \theta) \\ &= w \cos \theta \end{aligned}$$

Using, $v = u + at$

$$(-w \cos \theta) = (+v \sin \theta) + (-g)T$$

[where T = time from P to Q]

$$\begin{aligned} \Rightarrow gT &= v \sin \theta + w \cos \theta \\ &= v \sin \theta + v \cot \theta \cos \theta \\ &= v \sin \theta + v \cdot \frac{\cos^2 \theta}{\sin \theta} \\ &= v \operatorname{cosec} \theta \\ \therefore t &= \frac{v \operatorname{cosec} \theta}{g} \end{aligned}$$

Option (c) is correct.

Option (d) is incorrect.

4. $\vec{v} = 10 \hat{i} + 10 \hat{j}$

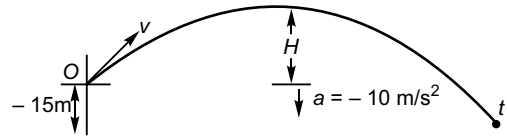

If θ be the angle of projection

$$\tan \theta = \frac{v_y}{v_x} = \frac{10}{10} = 1$$

i.e., $\theta = 45^\circ$

Option (a) correct.

Using relation, $s = ut + \frac{1}{2}at^2$

$$(-15) = 10t + \frac{1}{2}(-10)t^2$$

i.e., $t^2 - 2t - 3 = 0$

or $(t - 3)(t + 1) = 0$

$\therefore t = 3$ s

Option (b) is incorrect.

Horizontal range of particle

$$\begin{aligned} &= v_x \cdot t \\ &= 10 \times 3 = 30 \text{ m} \end{aligned}$$

Option (c) is incorrect.

Maximum height of projectile from ground

$$\begin{aligned} &= H + 15 \\ &= \frac{u^2 \sin^2 \theta}{2g} + 15 \\ &= \frac{v_y^2}{2g} + 15 \\ &= \frac{(10)^2}{2 \times 10} + 15 \\ &= 20 \text{ m} \end{aligned}$$

Option (d) is correct.

5. Average velocity between any two points can't remain constant as in projectile motion velocity changes both in magnitude and direction.

Option (a) is incorrect.

Similarly option (b) is also incorrect.

Projectile Motion 71

In projectile motion

$$\vec{a} = \text{constant}$$

$$\therefore \frac{d\vec{v}}{dt} = \text{constant}$$

Option (c) is correct.

also
$$\frac{d^2\vec{v}}{dt^2} = 0$$

Option (d) is correct.

6.
$$(+h) = (+u \sin \alpha)t + \frac{1}{2}(-g)t^2$$

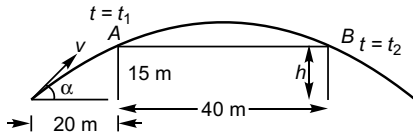

$$\Rightarrow gt^2 - (2u \sin \alpha)t + 2h = 0 \quad \dots(i)$$

$$t_1 + t_2 = \frac{2u \sin \alpha}{g}, \quad t_1 t_2 = \frac{2h}{g}$$

$$(t_2 - t_1)^2 = (t_2 + t_1)^2 - 4t_1 t_2$$

$$= \frac{4u^2 \sin^2 \alpha}{g} = 4 \cdot \frac{2h}{g}$$

$$\therefore t_{AB} = \sqrt{\frac{8(H-h)}{g}}$$

[where $H =$ Maximum height]

$$\Rightarrow 2 = \sqrt{\frac{8(H-15)}{10}}$$

$$\therefore H = 20 \text{ m}$$

Option (b) is correct.

i.e.,
$$\frac{u^2 \sin^2 \alpha}{2g} = 20$$

$$u \sin \alpha = \sqrt{40g}$$

$$= 20 \text{ m/s}$$

Option (c) is correct.

$$(u \cos \alpha)t_{AB} = 40$$

$$\Rightarrow u \cos \alpha = \frac{40}{2}$$

$$= 20 \text{ m/s}$$

Option (d) is correct.

Substituting values of g , $u \sin \alpha$ and h in Eq. (i)

$$10t^2 - 40t + 30 = 0$$

i.e.,
$$t^2 - 4t + 3 = 0$$

$$\therefore t = 1 \text{ or } 3$$

$t = 1 \text{ s}$ for A and $t = 3 \text{ s}$ for B.

Option (a) is correct.

Match the Columns

1. (a) At $t = 2 \text{ s}$

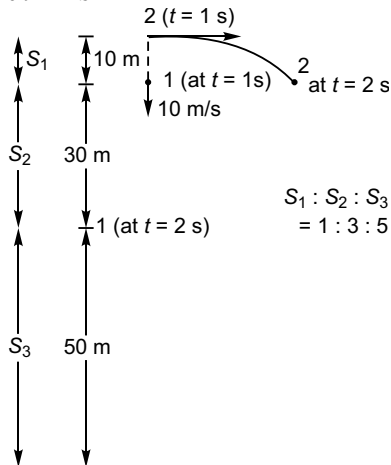

horizontal distance between 1 and 2
= horizontal displacement of 2
= $10 \times 1 = 10 \text{ m}$

\therefore (a) \rightarrow (p)

(b) Vertical distance between the two

at $t = 2 \text{ s} = 30 \text{ m}$

\therefore (b) \rightarrow (s)

(c) Relative horizontal component of velocity

$$= 10 - 0 = 10 \text{ m/s}$$

\therefore (c) \rightarrow (p)

(d) Relative vertical component of velocity (at $t = 2 \text{ s}$)

= Velocity of 1 at $t = 2 \text{ s}$

- Vertical velocity of 2 at $t = 2 \text{ s}$

= Velocity of 1 at $t = 2 \text{ s}$

- Velocity of 1 at $t = 1 \text{ s}$

$$= (2g) - (1g) = g$$

$$= 10 \text{ m/s}$$

(d) \rightarrow (p).

72 | Mechanics-1

2. Given, $H = 20 \text{ m}$

$$\therefore \frac{u^2 \sin^2 \alpha}{2g} = 20$$

$$u \sin \alpha = 20$$

\therefore (d) \rightarrow (s)

$$\text{Time of flight} = \frac{2u \sin \alpha}{g} = 4 \text{ s}$$

(a) \rightarrow (s)

$$H = \frac{R}{2} \quad (\text{given})$$

$$\therefore \frac{u^2 \sin^2 \alpha}{2g} = \frac{1}{2} \frac{2u^2 \sin \alpha \cos \alpha}{g}$$

$$\Rightarrow \frac{u \sin \alpha}{u \cos \alpha} = 2$$

\therefore (b) \rightarrow (q)

$$u \cos \alpha = \frac{u \sin \alpha}{2} = 10 \text{ m/s}$$

\therefore (c) \rightarrow (r)

3. $\frac{u^2 \sin (2 \times 15^\circ)}{2g} = 10$

$$\therefore \frac{u^2}{2g} = 20 \text{ m}$$

$$\Rightarrow R_{\max} = 20 \text{ m}$$

(a) \rightarrow (q)

(b) Maximum height = $\frac{u^2}{4g} = 10 \text{ m}$

\therefore (b) \rightarrow (p)

(c) Range at $(45^\circ + \theta) = \text{Range at } (45^\circ - \theta)$

$$\therefore \text{Range at } 75^\circ = \text{Range at } 15^\circ = 10 \text{ m (given)}$$

(c) \rightarrow (p)

(d) Height at $30^\circ = \frac{u^2 \sin^2 30^\circ}{2g}$
 $= \frac{1}{4} \left(\frac{u^2}{2g} \right)$
 $= 5 \text{ m}$

\therefore (d) \rightarrow (s)

4. (a) $T = \frac{2u \sin \alpha}{g}$
 $= \frac{2u_\perp}{g}$

\therefore On increasing u_\perp to two times the T (time) of flight will also become two times i.e., (a) \rightarrow (q).

(b) $H = \frac{u^2 \sin^2 \alpha}{2g} = \left(\frac{u_\perp}{2g} \right)^2$

H_{\max} will become 4 times.

\therefore (b) \rightarrow (r)

(c) $R = \frac{2(u_\perp)(u_\parallel)}{g}$

R will become two times

(c) \rightarrow (q)

(d) Angle of projection with horizontal

$$\begin{aligned} \tan \alpha_{\text{new}} &= \frac{u_\perp(\text{new})}{u_\parallel} \\ &= \frac{2u_\perp}{u_\parallel} \\ &= 2 \tan \alpha \end{aligned}$$

$$\alpha_{\text{new}} = \tan^{-1}(2 \tan \alpha) \neq 2\alpha$$

\therefore (d) \rightarrow (s)

5. (a) \vec{u} (at 0) = $(u \cos \theta) \hat{i} + (u \sin \theta) \hat{j}$

$$\vec{v}$$
 (at A) = $(u \cos \theta) \hat{i}$

|Change in velocity between A & B|
 $= u \sin \theta$

\therefore (a) \rightarrow (q)

(b) |Average velocity between 0 and A|

$$\begin{aligned} &= \frac{|\vec{OA}|}{T/2} \\ &= \frac{\sqrt{H^2 + \left(\frac{R}{2}\right)^2}}{T/2} \\ &= \frac{\sqrt{\left[\left(\frac{u^2 \sin^2 \theta}{2g}\right)^2 + \frac{1}{4} \left(\frac{2u \sin \theta \cos \theta}{g}\right)^2\right]}}{\frac{u \sin \theta}{g}} \\ &= \frac{u}{2} \sqrt{1 + 3 \cos^2 \theta} \end{aligned}$$

\therefore (b) \rightarrow (s)

(c) Velocity at B

$$\vec{v}_B = (u \cos \theta) \hat{i} - (u \sin \theta) \hat{j}$$

$$\therefore |\vec{v}_B - \vec{u}| = 2u \sin \theta$$

Thus, (c) \rightarrow (s).

(d) |Average velocity between 0 and B|

$$\begin{aligned} &= \frac{\text{Range}}{\text{Time of flight}} \\ &= \frac{(u \cos \theta) T}{T} = u \cos \theta \end{aligned}$$

\therefore (d) \rightarrow (p).

6. (a) Horizontal displacement of (1) at $t = 2$ s

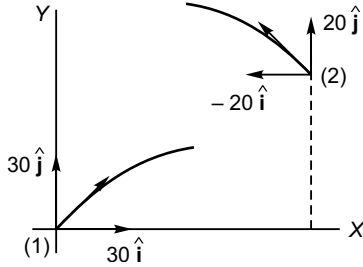

$$\begin{aligned} \vec{S}_{1H} &= 30\hat{i} \text{ m/s} \times 2 \text{ s} \\ &= +60\hat{i} \text{ m} \end{aligned}$$

Horizontal displacement of (2) at $t = 2$ s

$$\begin{aligned} \vec{S}_{2H} &= 130\hat{i} \text{ m} + (-20\hat{i} \text{ m/s})(1 \text{ s}) \\ &= 110\hat{i} \text{ m} \end{aligned}$$

Horizontal displacement of (2) w.r.t. (1)

$$= (110\hat{i} - 60\hat{i}) \text{ m} = 50\hat{i} \text{ m}$$

\therefore (a) \rightarrow (r)

(b) Vertical displacement of (1) at $t = 2$ s

$$\begin{aligned} \vec{S}_{1V} &= 30\hat{j} \text{ m/s} \times 2 \text{ s} + \frac{1}{2}(-10\hat{j} \text{ m/s}^2)(2 \text{ s})^2 \\ &= 60\hat{j} \text{ m} - 20\hat{j} \text{ m} \\ &= 40\hat{j} \text{ m} \end{aligned}$$

Vertical displacement of (2) at $t = 2$ s

$$\begin{aligned} \vec{S}_{2V} &= 75\hat{j} \text{ m} + (20\hat{j} \text{ m/s})(1 \text{ s}) \\ &\quad + \frac{1}{2}(-10\hat{j} \text{ m/s}^2)(1 \text{ s})^2 \\ &= 90\hat{j} \text{ m} \end{aligned}$$

\therefore Vertical displacement of (2) w.r.t. (1),

$$\begin{aligned} &= (90\hat{j} - 40\hat{j}) \text{ m} \\ &= 50\hat{j} \text{ m} \end{aligned}$$

\therefore (b) \rightarrow (r)

(c) Horizontal velocity of (1) at $t = 2$ s

$$\vec{v}_{1H} = 30\hat{i}$$

Horizontal velocity of (2) at $t = 2$ s

$$\vec{v}_{2H} = -20\hat{i}$$

Relative horizontal component of the velocity of (2) w.r.t. 1

$$\begin{aligned} \vec{v}_{RH} &= \vec{v}_{2H} - \vec{v}_{1H} \\ &= (-20\hat{i}) - (+30\hat{i}) \\ &= -50\hat{i} \text{ m/s} \end{aligned}$$

$$\therefore |\vec{v}_{RH}| = 50 \text{ m/s}$$

Thus, (c) \rightarrow (r)

(d) Vertical velocity of (1) at $t = 2$ s

$$\begin{aligned} \vec{v}_{1V} &= 30\hat{j} + (-10\hat{j})(2) \\ &= 10\hat{j} \end{aligned}$$

Vertical velocity of (2) at $t = 2$ s

$$\begin{aligned} \vec{v}_{2V} &= 20\hat{j} + (-10\hat{j})(1) \\ &= 10\hat{j} \end{aligned}$$

Relative vertical component of the velocity of (2) w.r.t. 1

$$\vec{v}_{RV} = (10\hat{j}) - (10\hat{j}) = 0$$

$$\therefore |\vec{v}_{RV}| = 0 \text{ m/s}$$

Thus (d) \rightarrow (s)

$$7. T = \frac{2u_y}{g} \quad \therefore T \propto u_y$$

$$H = \frac{u_y^2}{2g} \quad \therefore H \propto u_y^2$$

$$H_A = H_B = H_C \quad \therefore T_A = T_B = T_C$$

Further, $R = u_x T$

T is same. But

$$R_A < R_B < R_C$$

$$\therefore u_{XA} < u_{XB} < u_{XC}$$

5

Laws of Motion

Introductory Exercise 5.1

1. N = Normal force on cylinder by plank

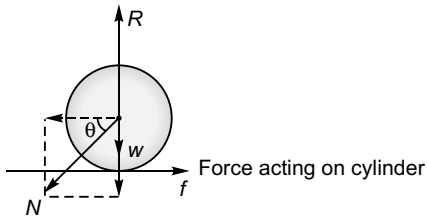

R = Normal force on cylinder by ground,
 f = Force of friction by ground by cylinder,
 w = Weight of cylinder.

$$N \cos \theta = f$$

$$w + N \sin \theta = R,$$

$N(R)$ = Reaction to N ,

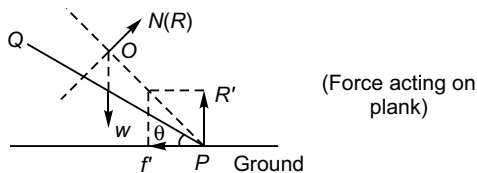

i.e., normal force on plank by cylinder

R' = Normal force on plank by ground,

w = Weight of plank,

f' = frictional force on plank by ground.

Resultant of f' and R' , $N(R)$ and w pass through point O .

- 2.

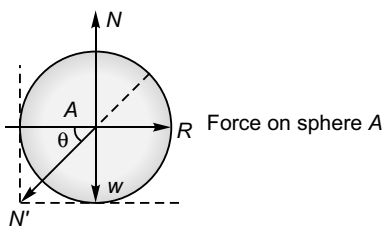

R = Normal force on sphere A by left wall,
 N = Normal force on sphere A by ground,
 N' = Normal force on sphere A by sphere B ,
 w_A = Weight of sphere A .

$$N' \cos \theta = R$$

$$N' \sin \theta + w_A = N$$

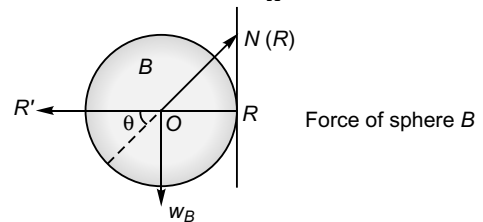

R' = Normal force on sphere B by right wall,

$N(R)$ = Reaction to N *i.e.* normal force on sphere B by sphere A ,

w_B = Weight of sphere B ,

R' , $N(R)$ and w_B pass through point O , the centre sphere B .

3. N = Normal force on sphere by wall,

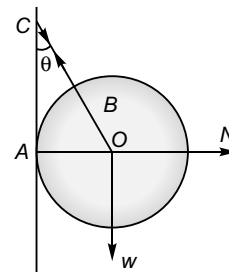

w = Weight of sphere,
 T = Tension in string.

4. Component of \vec{F}_1

along x -axis : $4 \cos 30^\circ = 2\sqrt{3}$ N

along y -axis : $4 \sin 30^\circ = 2$ N

Component of \vec{F}_2

along x -axis : $4 \cos 120^\circ = -2$ N

along y -axis : $4 \sin 120^\circ = 2\sqrt{3}$ N

Component of \vec{F}_3

along x -axis : $6 \cos 270^\circ = 0$ N

along y -axis : $6 \sin 270^\circ = -6$ N

Component of \vec{F}_4

along x -axis : $4 \cos 0^\circ = 4$ N

along y -axis : $4 \sin 0^\circ = 0$ N

5. Taking moment about point A

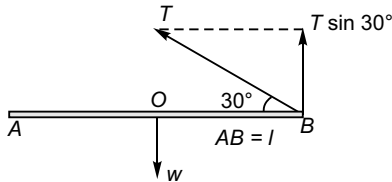

$$AB = l$$

$$(T \sin 30^\circ) l = w \frac{l}{2}$$

$$\Rightarrow T = w$$

6. See figure (answer to question no. 3)

$$\sin \theta = \frac{OA}{OB + BC}$$

$$= \frac{a}{a + a} = \frac{1}{2}$$

$$T \cos 30^\circ = w$$

or $T \frac{\sqrt{3}}{2} = w$

or $T = \frac{2}{\sqrt{3}} w$

7. $R \cos 30^\circ + 3 = f \cos 60^\circ$

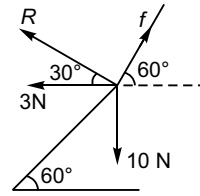

i.e., $\frac{R\sqrt{3}}{2} + 3 = \frac{f}{2}$

or $R\sqrt{3} + 6 = f$... (i)

and $R \sin 30^\circ + f \sin 60^\circ = 10$

i.e., $R \frac{1}{2} + f \frac{\sqrt{3}}{2} = 10$

or $R + f\sqrt{3} = 20$... (ii)

Substituting the value of f from Eq. (i) in Eq. (ii)

$$R + (R\sqrt{3} + 6)\sqrt{3} = 20$$

$$4R + 6\sqrt{3} = 20$$

$$\Rightarrow R = \frac{20 - 6\sqrt{3}}{4} = 2.4 \text{ N}$$

$$\therefore f = (2.4)\sqrt{3} + 6 = 10.16 \text{ N}$$

8. At point B (instantaneous vertical acceleration only)

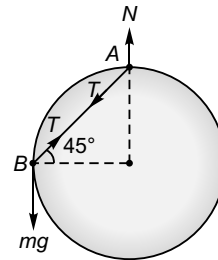

$$\therefore mg - T \sin 45^\circ = ma$$
 ... (i)

At point A (instantaneous horizontal acceleration only)

$$\therefore T \cos 45^\circ = ma$$
 ... (ii)

Combining Eqs. (i) and (ii)

$$mg - ma = ma$$

$$\Rightarrow a = \frac{g}{2}$$

Introductory Exercise 5.2

1. Acceleration of system

$$a = \frac{(+120) + (-50)}{1 + 4 + 2}$$

$$= 10 \text{ m/s}^2$$

Let normal force between 1 kg block and 4 kg block = F_1

∴ Net force on 1 kg block = $120 - N$

$$\therefore a = \frac{120 - F_1}{1}$$

or $10 = 120 - F_1$

i.e., $F_1 = 110 \text{ N}$

$$\begin{aligned} \text{Net force on 2 kg block} &= 2 \times a \\ &= 2 \times 10 \\ &= 20 \text{ N} \end{aligned}$$

2. As, $4g \sin 30^\circ > 2g \sin 30^\circ$

The normal force between the two blocks will be zero.

3. $N(R) = \frac{mg}{4}$

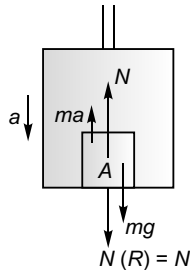

$$\therefore N = \frac{mg}{4}$$

As lift is moving downward with acceleration a , the pseudo force on A will be ma acting in the upward direction. For the block to be at rest w.r.t. lift.

$$N + ma = mg$$

or $\frac{mg}{4} + ma = mg$

$$\Rightarrow a = \frac{3}{4}g$$

4. Angle made by the string with the normal to the ceiling = $\theta = 30^\circ$

As the train is moving with constant velocity no pseudo force will act on the plumb-bob.

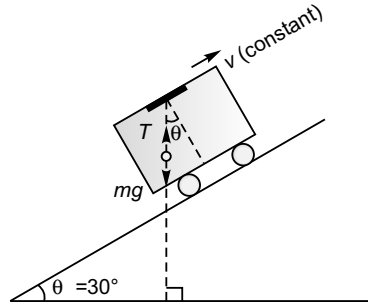

$$\begin{aligned} \text{Tension in spring} &= mg \\ &= 1 \times 10 \\ &= 10 \text{ N} \end{aligned}$$

5. Pseudo force ($= ma$) on plumb-bob will be as shown in figure

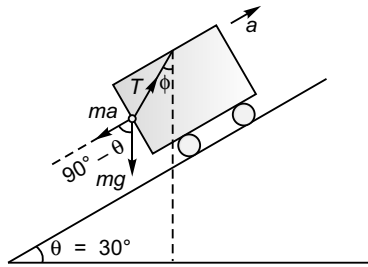

$$T \cos \phi = mg + ma \cos (90^\circ - \theta)$$

i.e., $T \cos \phi = mg + ma \sin \theta$... (i)

and $T \sin \phi = ma \cos \theta$

Squaring and adding Eqs. (i) and (ii),

$$T^2 = m^2 g^2 + m^2 a^2 \sin^2 \theta + 2m^2 ag \sin \theta + m^2 a^2 \cos^2 \theta$$

$$T^2 = m^2 g^2 + m^2 a^2 + m^2 ag \quad (\because \theta = 30^\circ)$$

$$= m^2 g^2 + m^2 \frac{g^2}{4} + m^2 \frac{g}{2} \cdot g \quad (\because a = \frac{g}{2})$$

$$= \frac{7 m^2 g^2}{4}$$

or $T = \frac{mg\sqrt{7}}{2}$

$$= 5\sqrt{7} \text{ N}$$

Dividing Eq. (i) by Eq. (ii),

$$\tan \phi = \frac{ma \cos \theta}{mg + ma \sin \theta}$$

$$\begin{aligned}
 &= \frac{a \cos \theta}{g + a \sin \theta} \\
 &= \frac{\cos \theta}{2 + \sin \theta} \\
 &= \frac{\cos 30^\circ}{2 + \sin 30^\circ} \\
 &= \frac{\sqrt{3}}{5} \\
 \text{i.e., } \phi &= \tan^{-1} \left[\frac{\sqrt{3}}{5} \right]
 \end{aligned}$$

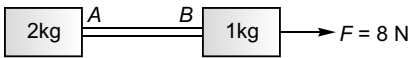
6. 

$$a = \frac{8}{2 + 1 + 1} = 2 \text{ m/s}^2$$

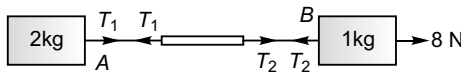

Net force on 1 kg mass = $8 - T_2$
 $\therefore 8 - T_2 = 1 \times 2$
 $\Rightarrow T_2 = 6 \text{ N}$

Net force on 1 kg block = T_1
 $\therefore T_1 = 2a = 2 \times 2 = 4 \text{ N}$

Introductory Exercise 5.3

1. $F = 2g \sin 30^\circ = g$

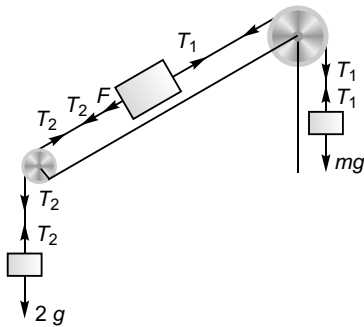

For the system to remain at rest

$$T_2 = 2g \quad \dots\text{(i)}$$

$$T_2 + F = T_1 \quad \dots\text{(ii)}$$

or $T_2 + g = T_1 \quad \dots\text{[ii (a)]}$

$$T_1 = mg \quad \dots\text{(iii)}$$

Substituting the values of T_1 and T_2 from Eqs. (iii) and (i) in Eq. [ii(a)]

$$2g + g = mg$$

i.e., $m = 3 \text{ kg}$

2. As net downward force on the system is zero, the system will be in equilibrium

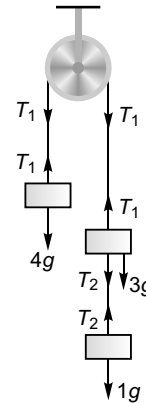

$$\therefore T_1 = 4g$$

and $T_2 = 1g$

$$\therefore \frac{T_1}{T_2} = 4$$

3. $2g - T = 2a$

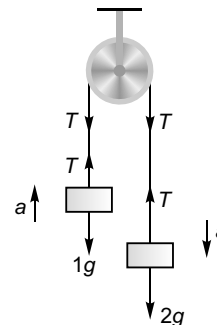

$$T - 1g = 1a$$

Adding above two equations

$$1g = 3a$$

$$\therefore a = \frac{g}{3}$$

Velocity of 1kg block 1 section after the system is set in motion

$$\begin{aligned} v &= 0 + at \\ &= \frac{g}{3} \cdot 1 \\ &= \frac{g}{3} \quad \text{(upward)} \end{aligned}$$

On stopping 2 kg, the block of 1kg will go upwards with retardation g . Time (t') taken by the 1 kg block to attain zero velocity will be given by the equation.

$$0 = \left(\frac{g}{3}\right) + (-g)t'$$

$$\Rightarrow t' = \frac{1}{3} \text{ s}$$

If the 2 kg block is stopped just for a moment (time being much-much less than $\frac{1}{3}$ s), it will also start falling down when the stopping time ends.

In $t' \left(= \frac{1}{3} \text{ s} \right)$ time upward displacement of 1 kg block

$$= \frac{u^2}{2a} = \frac{(g/3)^2}{2g} = \frac{g}{18}$$

Downward displacement of 2 kg block

$$= \frac{1}{2}at^2 = \frac{1}{2}g \cdot \left(\frac{g}{3}\right)^2 = \frac{g}{18}$$

As the two are just equal, the string will again become taut after time $\frac{1}{3}$ s.

$$4. \quad F + 1g - T = 1a \quad \dots(i)$$

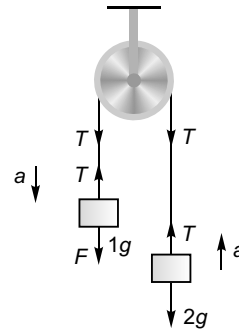

$$\text{and} \quad T - 2g = 2a \quad \dots(ii)$$

Adding Eqs. (i) and (ii),

$$F - 1g = 3a$$

$$\therefore a = \frac{20 - 10}{3} = \frac{10}{3} \text{ ms}^{-2}$$

Introductory Exercise 5.4

$$1. \quad 2T = 2 \times a \quad \dots(i)$$

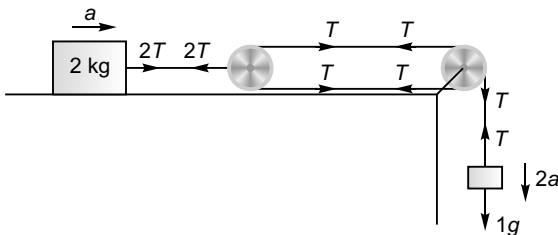

$$\text{and} \quad 1g - T = 2a \quad \dots(ii)$$

Solving Eqs. (i) and (ii),

$$a = \frac{g}{3}$$

\therefore Acceleration of 1 kg block

$$2a = \frac{2g}{3} = \frac{20}{3} \text{ ms}^{-2}$$

Tension in the string

$$T = \frac{g}{3} = \frac{10}{3} \text{ N}$$

$$2. \quad Mg - T = Ma \quad \dots(i)$$

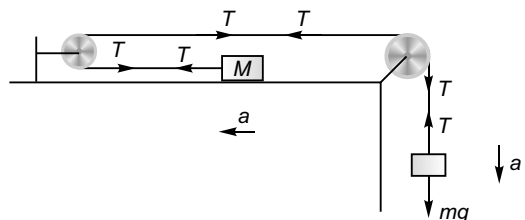

$$T = Ma \quad \dots(ii)$$

Solving Eqs. (i) and (ii)

$$a = \frac{g}{2}$$

and $T = Mg$

3. Block of mass M will be at rest if

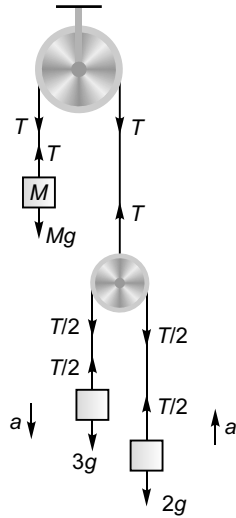

$$T = Mg \quad \dots(i)$$

For the motion of block of mass 3 kg

$$3g - \frac{T}{2} = 3a \quad \dots(ii)$$

For the motion of block of mass 2 kg

$$\frac{T}{2} - 2g = 2a \quad \dots(iii)$$

Adding Eqs. (ii) and (iii),

$$g = 5a$$

i.e., $a = \frac{g}{5}$

Substituting above value of a in Eq. (iii),

$$\frac{T}{2} = 2(g + a)$$

or $T = 4 \left(g + \frac{g}{5} \right) = \frac{24g}{5}$

Substituting value of above value of T in Eq. (i),

$$M = \frac{24}{5} = 4.8 \text{ kg}$$

4. $\frac{T}{2} = m_1 \cdot 2a$

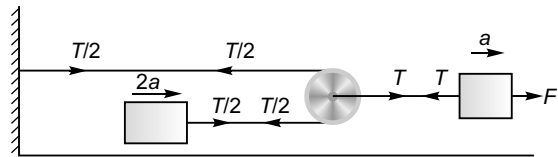

i.e., $T = 4m_1a \quad \dots(i)$

$F - T = m_2a \quad \dots(ii)$

or $F - 4m_1a = m_2a$

or $a = \frac{F}{4m_1 + m_2}$

$$= \frac{0.40}{(4 \times 0.3) + 0.2}$$

$$= \frac{0.40}{1.4}$$

$$= \frac{2}{7} \text{ ms}^{-2}$$

$\therefore T = 4m_1a$

$$= 4 \times 0.3 \times \frac{2}{7}$$

$$= \frac{2.4}{7}$$

$$= \frac{12}{35} \text{ N}$$

Introductory Exercise 5.5

1. Block on triangular block will not slip if

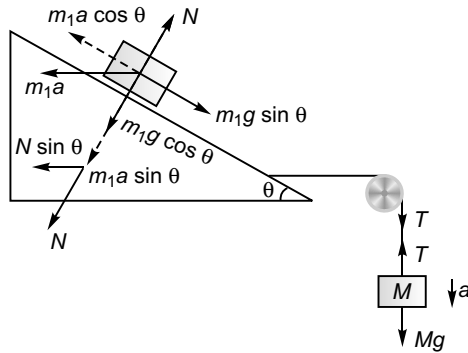

$$m_1 a \cos \theta = m_1 g \sin \theta$$

i.e., $a = g \tan \theta$... (i)

$$N = m_1 g \cos \theta + m_1 a \sin \theta$$
 ... (ii)

For the movement of triangular block

$$T - N \sin \theta = m_2 a$$
 ... (iii)

For the movement of the block of mass M

$$Mg - T = Ma$$
 ... (iv)

Adding Eqs. (iii) and (iv),

$$Mg - N \sin \theta = (m_2 + M) a$$

Substituting the value of N from Eq. (ii) in the above equation

$$Mg - (m_1 g \cos \theta + m_1 a \sin \theta) \sin \theta = (m_2 + M) a$$

i.e., $M(g - a) = m_1 g \cos \theta \sin \theta + (m_2 + m_1 \sin^2 \theta) a$

Substituting value of a from Eq. (i) in the above equation,

$$M(1 - \tan \theta) = m_1 \cos \theta \sin \theta + (m_2 + m_1 \sin^2 \theta) \tan \theta$$

$$\therefore M = \frac{m_1 \cos \theta \sin \theta + (m_2 + m_1 \sin^2 \theta) \tan \theta}{(1 - \tan \theta)}$$

Substituting $\theta = 30^\circ$, $m_1 = 1$ kg and

$$M = \frac{\cos 30^\circ \sin 30^\circ + 4 + \sin^2 30^\circ \tan 30^\circ}{(1 - \tan 30^\circ)} = \frac{0.443 + (4.25)(0.577)}{0.423} = 6.82 \text{ kg}$$

2. (a) Using $s = s_0 + ut + \frac{1}{2}at^2$

Displacement of block at time t relative to car would be

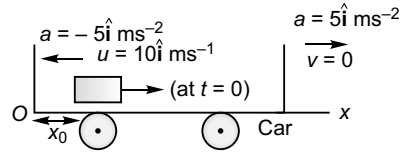

$$x = x_0 + 10t + \frac{1}{2}(-5)t^2$$

or $x = x_0 + 10t - 2.5t^2$

Velocity of block at time t (relative to car) will be

$$v = \frac{dx}{dt} = 10 - 5t$$

(b) Time (t) for the block to arrive at the original position (i.e., $x = x_0$) relative to car

$$x_0 = x_0 + 10t - 2.5t^2$$

$$\Rightarrow t = 4 \text{ s}$$

3. (a) In car's frame position of object at time t would be given by

In car's frame

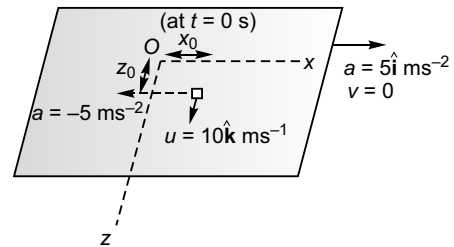

$$x = x_0 + 0 \times t + \frac{1}{2}(-5)t^2$$

i.e., $x = x_0 - 2.5t^2$... (i)

and $z = z_0 + 10t$... (ii)

Velocity of the object at time t would be

$$v_x = \frac{dx}{dt} = -5t$$
 ... (iii)

and $v_z = \frac{dz}{dt} = 10$... (iv)

(b) In ground frame the position of the object at time t would be given by

In ground frame

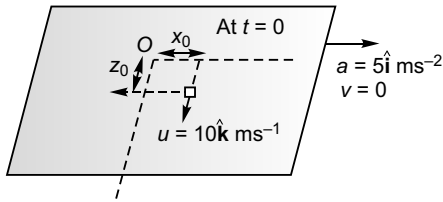

$$x = x_0$$

and

$$z = z_0 + 10t$$

Velocity of the object at time t would be

$$v_x = \frac{dx}{dt} = 0$$

and

$$v_z = \frac{dz}{dt} = 10 \text{ ms}^{-1}$$

4. $m = 2 \text{ kg}$

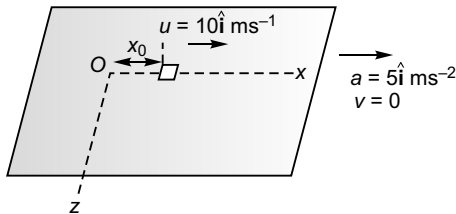

Normal force on object = mg

Maximum sliding friction = $\mu_s mg$

$$= 0.3 \times 2 \times 10 = 6 \text{ N}$$

Deceleration due to friction = $\frac{6}{2} = 3 \text{ m/s}^2$

Deceleration due to pseudo force = 5 m/s^2

$$\therefore \text{Net deceleration} = (3 + 5) \text{ m/s}^2 = 8 \text{ m/s}^2$$

\therefore Displacement of object at any time t (relative to car)

$$x = x_0 + 10t + \frac{1}{2}(-8)t^2$$

or

$$x = x_0 + 10t - 4t^2$$

Thus, velocity of object at any time t (relative to car)

$$v_x = \frac{dx}{dt} = 10 - 8t$$

The object will stop moving relative to car when

$$10 - 8t = 0 \text{ i.e., } t = 1.25 \text{ s}$$

$$\therefore v_x = 10 - 8t \text{ for } 0 < t < 1.25 \text{ s}$$

For block not to slide the frictional force (f) would be given by

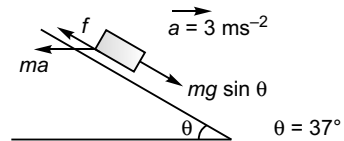

$$f + ma \cos \theta = mg \sin \theta$$

or

$$\begin{aligned} f &= mg \sin \theta - ma \cos \theta \\ &= m \times 10 \times \frac{3}{5} - m \times 3 \times \frac{4}{5} \\ &= \frac{18m}{5} = \frac{9}{25} mg \end{aligned}$$

AIEEE Corner

Subjective Questions (Level 1)

1. FBD is given in the answer.
2. FBD is given in the answer.
3. FBD is given in the answer.
- 4.

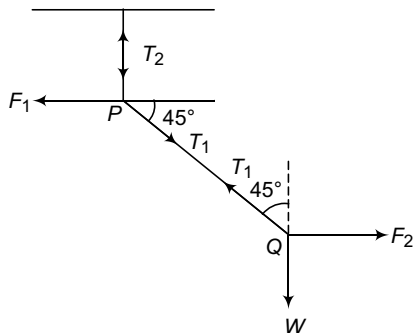

At point P, $F_1 = \frac{T_1}{\sqrt{2}}$ and $T_2 = \frac{T_1}{\sqrt{2}}$

At point Q, $F_2 = \frac{T_1}{\sqrt{2}}$ and $W = \frac{T_1}{\sqrt{2}}$

5.

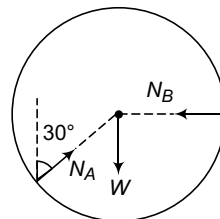

$$N_A \sin 30^\circ = N_B$$

$$\text{and } N_A \cos 30^\circ = W$$

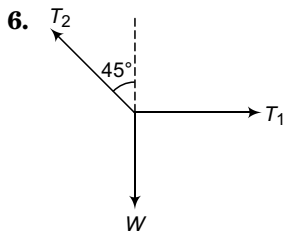

$$\frac{T_2}{\sqrt{2}} = W \text{ and}$$

$$\frac{T_2}{\sqrt{2}} = T_1$$

7.

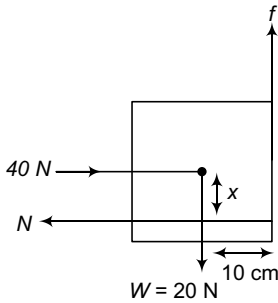

$$N = 40$$

$$f = 20$$

$$f \times 10 = N \times x$$

8.

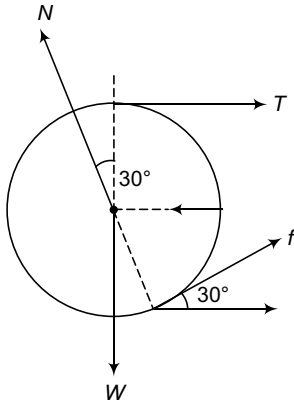

$$T + f \cos 30^\circ = N \sin 30^\circ$$

$$N \cos 30^\circ + f \sin 30^\circ = W$$

$$T \times R = fR$$

9.

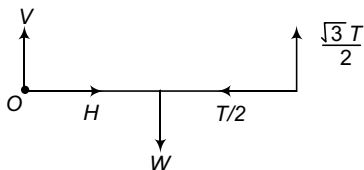

$$V + \frac{\sqrt{3}T}{2} = W \quad \dots(i)$$

$$H = \frac{T}{2} \quad \dots(ii)$$

Net moment about O = zero

$$\therefore W \times \frac{l}{2} = \frac{\sqrt{3}T}{2} \times l \quad \dots(iii)$$

10. (a) $a = \frac{100 - 40}{6 + 4 + 10} = 3 \text{ m/s}^2$

(b) Net force = ma

$$\therefore F_6 = 18 \text{ N}, F_4 = 12 \text{ N and } F_{10} = 30 \text{ N}$$

(c) $N - 40 = F_{10} = 30$

$$\therefore N = 70 \text{ N.}$$

11. $a = \frac{F}{m_1 + m_2 + m_3} = \frac{60}{60} = 1 \text{ m/s}^2$

(a) $T_1 = m_1 a = 10 \text{ N}$

$$T_2 - T_1 = m_2 a$$

$$\therefore T_2 - 10 = 20$$

$$\therefore T_2 = 30 \text{ N}$$

(b) $T_1 = 0$. New acceleration

$$a' = \frac{60}{50} = 1.2 \text{ m/s}^2$$

$$T_2 = m_2 a' = 24 \text{ N}$$

12. (a)

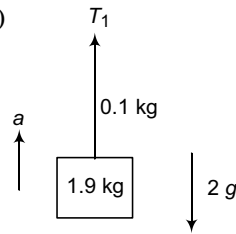

$$T_1 - 2g = 2a$$

(b)

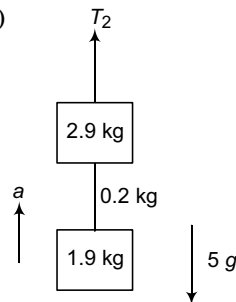

$$T_2 - 5g = 5a$$

13. (a) $a = \frac{200 - 16g}{16}$

(b) $T_1 - 11g = 11a$

(c) $T_2 - 9g = 9a$

14. If the monkey exerts a force F on the rope upwards, then same force F transfers to bananas also. If monkey releases her hold on rope both monkey and bananas fall freely under gravity.

15. Tension on $B = T$

Tension on $A = 3T$

Now in these situations $a \propto \frac{1}{T}$

16. $x_A + x_C + 2x_B = \text{constant}$.

Differentiating twice w.r.t. time we get the acceleration relation.

17.

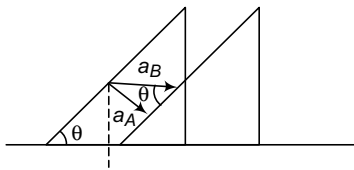

$$\frac{a_A}{a_B} = \sin \theta$$

$\therefore a_A = a_B \sin \theta$

18. $x + y = 6$... (i)

$y - x = 4$... (ii)

Solving, we get

$x = 1 \text{ m/s}^2$

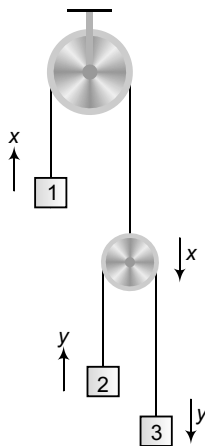

19.

$$a = \frac{7g - 3g}{10} = 4 \text{ m/s}^2$$

$$40 - T_1 = 4a$$

$$30 + T_1 - T_2 = 3a$$

$$T_3 - 10 = 1a$$

20.

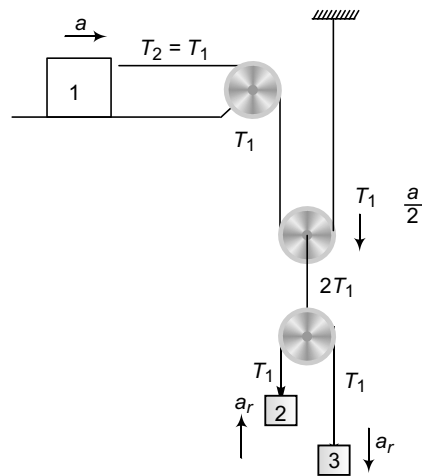

$T_1 = 1a$... (i)

$T_1 - 20 = 2(a_r - a/2)$... (ii)

$30 - T_1 = 3(a_r + a/2)$... (iii)

21.

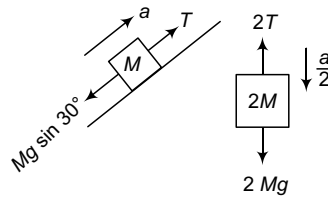

$T - Mg \sin 30^\circ = Ma$... (i)

$2Mg - 2T = 2M \cdot \frac{a}{2}$... (ii)

22. $T = 1a$... (i)

$10 - T = 1a$... (ii)

23.

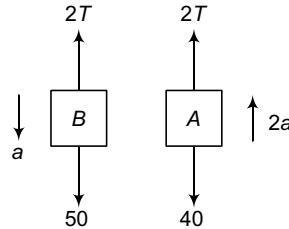

$50 - 2T = 5a$... (i)

$T - 40 = 4(2a)$... (ii)

24. (a) $N = 40 \text{ N}$, $\mu_s N = 24 \text{ N}$

$F < \mu_s N$

$\therefore f = 20 \text{ N}$ and $a = 0$

(b) $N = 20 \text{ N}$, $\mu_s N = 12 \text{ N}$

and $\mu_k N = 8 \text{ N}$

$$F > \mu_s N$$

$$\therefore f = \mu_k N = 8 \text{ N}$$

$$\text{and } a = \frac{20 - 8}{2} = 6 \text{ m/s}^2$$

$$(c) N = 60 - 20 = 40 \text{ N}$$

$$\mu_s N = 8 \text{ N and}$$

$$\mu_k N = 4 \text{ N}$$

Since, $F \cos 45^\circ > \mu_s N$

$$\therefore f = \mu_k N = 4 \text{ N}$$

$$\text{and } a = \frac{20 - 4}{6} = \frac{8}{3} \text{ m/s}^2$$

$$25. a = \mu g = 3 \text{ m/s}^2$$

$$(a) v = at$$

$$\therefore 6 = 3t \text{ or } t = 2 \text{ s}$$

$$(b) s = \frac{1}{2} at^2$$

$$\therefore s = \frac{1}{2} \times 3 \times 4 = 6 \text{ m.}$$

$$26. f = 0.4 \times 1 \times 10 = 4 \text{ N}$$

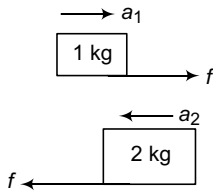

$$a_1 = \frac{f}{1} = 4 \text{ m/s}^2$$

$$a_2 = \frac{f}{2} = 2 \text{ m/s}^2$$

(a) Relative motion will stop when

$$v_1 = v_2$$

$$\text{or } 2 + 4t = 8 - 2t$$

$$\therefore t = 1 \text{ s}$$

$$(b) v_1 = v_2 = 2 + 4 \times 1 = 6 \text{ m/s}$$

$$(c) s_1 = u_1 t + \frac{1}{2} a_1 t^2$$

$$s_2 = u_2 t - \frac{1}{2} a_2 t^2$$

$$27. f = (0.6)(2)(10) = 12 \text{ N}$$

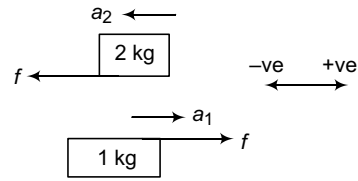

$$a_2 = \frac{12}{2} = 6 \text{ m/s}^2$$

$$\text{and } a_1 = \frac{12}{1} = 12 \text{ m/s}^2$$

(a) Relative motion will stop when

$$v_1 = v_2$$

$$\text{or } u_1 + a_1 t = u_2 + a_2 t$$

$$\text{or } 3 - 6t = -18 + 12t$$

$$\therefore t = \frac{7}{6} \text{ s}$$

(b) Common velocity at this instant is

$$v_1 \text{ or } v_2.$$

$$(c) s_1 = u_1 t + \frac{1}{2} a_1 t^2 \text{ and}$$

$$s_2 = u_2 t + \frac{1}{2} a_2 t^2$$

$$28. N = 20 \text{ N}$$

$$\mu_s N = 16 \text{ N}$$

$$\text{and } \mu_k N = 12 \text{ N}$$

Since, $W = 20 \text{ N} > \mu_s N$, friction $\mu_k N$ will act.

$$\therefore a = \frac{20 - 12}{2} = 4 \text{ m/s}^2$$

$$29. N = 20 \text{ N}$$

$$\mu N = 16 \text{ N}$$

Block will start moving when

$$F = \mu N$$

$$\text{or } 2t = 16$$

$$\text{or } t = 8 \text{ s.}$$

After 8 s

$$a = \frac{2t - 16}{2} = t - 8$$

i.e., $a-t$ graph is a straight line with positive slope and negative intercept.

$$30. N = 60 \text{ N, } \mu_s N = 36 \text{ N, } \mu_k N = 24 \text{ N}$$

Block will start moving when

$$F = \mu_s N$$

or $4t = 36$
 $\therefore t = 9 \text{ s}$

After 9 s

$$a = \frac{4t - 24}{6} = \frac{2}{3}t - 4$$

31. $N = mg \cos \theta = 30 \text{ N}$
 $mg \sin 30^\circ = 30\sqrt{3} \text{ N} \approx 52 \text{ N}$
 $\mu_s N = 18 \text{ N}$ and
 $\mu_k N = 12 \text{ N}$

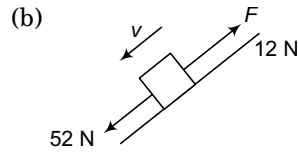
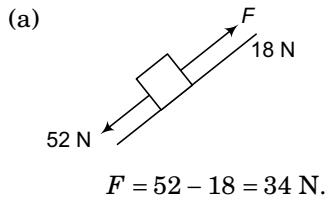

$$F + 12 = 52$$

$$\therefore F = 40 \text{ N}$$

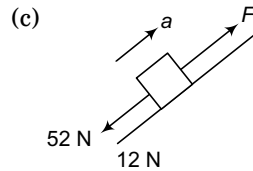

$$F - 52 - 12 = 6 \times 4$$

$$\therefore F = 88 \text{ N}$$

Objective Questions (Level-1)

Single Correct Option

1. $a = \frac{mg - F}{m} = g - \frac{F}{m}$
 $m_A > m_B$
 $\therefore a_A > a_B$
 or ball A reaches earlier.

2. $a = \frac{4g - 2g}{6} = \frac{g}{3}$
 Now, $2g - T = 2\frac{g}{3}$
 $\therefore T = \frac{4g}{3} = 13 \text{ N}$

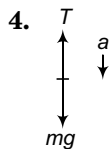
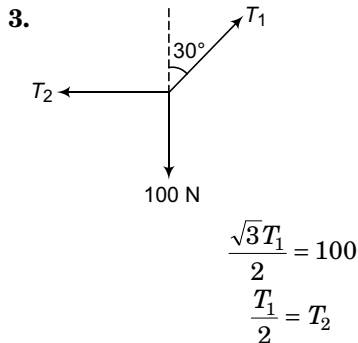

- $mg - T = ma$
 $\therefore a_{\min} = g - \frac{T_{\max}}{m}$
 $= g - \frac{\frac{2}{3}mg}{m} = \frac{g}{3}$
5. $a = \frac{10g - 5g}{15} = \frac{g}{3}$
 $10g - T = 10 \times \frac{g}{3}$
 $\therefore T = \frac{20g}{3} = \text{Reading of spring balance.}$

6. $a = \frac{2mg \sin 30^\circ - mg}{3m} = 0$
 $\therefore T = mg$

7. $a_1 = g \sin \theta - \mu g \cos \theta = g \sin 45^\circ - \mu g \cos 45^\circ$
 $a_2 = g \sin \theta = g \sin 45^\circ$
 Now $t = \sqrt{\frac{2s}{a}}$ or $t \propto \frac{1}{\sqrt{a}}$
 $\therefore \frac{t_1}{t_2} = \sqrt{\frac{a_2}{a_1}}$
 or $2 = \sqrt{\frac{g \sin 45^\circ}{g \sin 45^\circ - \mu g \cos 45^\circ}}$

Solving, we get $\mu = \frac{3}{4}$

86 | Mechanics-1

8. $F_1 = mg \sin \theta + \mu mg \cos \theta$

$F_2 = mg \sin \theta - \mu mg \cos \theta$

Given that $F_1 = 2F_2$

9. For equilibrium of block, net force from plane should be equal and opposite of weight.

10. No solution is required.

11. Angle of repose $\theta = \tan^{-1}(\mu) = 30^\circ$

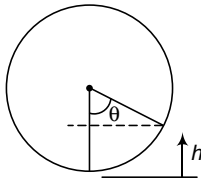

$\therefore h = R - R \cos \theta = \left(1 - \frac{\sqrt{3}}{2}\right)R$

12. Net pulling force = $15g - 5g = 10g = F$

Net retarding force = $(0.2)(5g) = g = f$

$\therefore a = \frac{F - f}{25} = \frac{9}{25}g$

$T_1 - 5g = 5a = \frac{9}{5}g$

$\therefore T_1 = \frac{34}{5}g$

$15g - T_2 = 15a = \frac{27}{5}g$

$\therefore T_2 = \frac{48}{5}g$

$\therefore \frac{T_1}{T_2} = \frac{17}{24}$

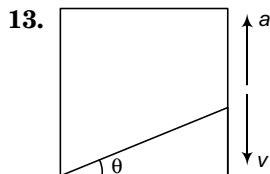

Relative to lift, $a_r = (g + a) \sin \theta$ along the plane.

Now, $t = \sqrt{\frac{2s}{a_r}}$
 $= \sqrt{\frac{2L}{(g + a) \sin \theta}}$

14. $f = mg \sin \theta$ (if block is at rest)

15. $2T \cos 30^\circ = F$

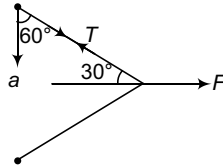

$\therefore T = \frac{F}{\sqrt{3}}$
 $a = \frac{T \cos 60^\circ}{m}$
 $= \frac{F}{2\sqrt{3}m}$

16.

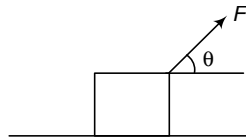

$N = mg - F \sin \theta$

$\mu N = (\tan \phi) N = (\tan \phi)(mg - F \sin \theta)$

$F \cos \theta = \mu N$

17. $\mu mg = 0.2 \times 4 \times 10 = 8 \text{ N}$

At $t = 2 \text{ s}$, $F = 4 \text{ N}$

Since $F < \mu mg$

\therefore Force of friction $f = F = 4 \text{ N}$

18. $a_1 = g \sin \theta$

$a_2 = g \sin \theta - \mu g \cos \theta$

$t = \sqrt{\frac{25}{a}}$ or $t \propto \frac{1}{\sqrt{a}}$

$\frac{t_1}{t_2} = \sqrt{\frac{a_2}{a_1}}$

$\frac{1}{2} = \sqrt{\frac{g \sin \theta - \mu g \cos \theta}{g \sin \theta}}$

19. Net acceleration of man relative to ground = $a + a = 2a$

$T - mg = m(2a)$

$\therefore T = m(g + 2a)$

20. $a = 0$

$3F = (50 + 25)g = 75g$

$\therefore F = 25g = 250 \text{ N}$

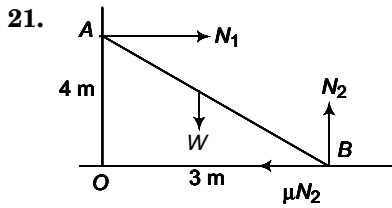

$$N_1 = \mu N_2$$

$$N_2 = W$$

Net moment about B should be zero.

$$\therefore W \times \frac{3}{2} = N_1 \times 4$$

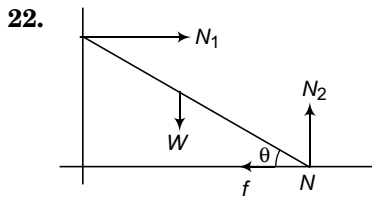

$$N_2 = W = 250 \quad (\text{always})$$

$$\therefore f_{\max} = \mu N_2 = 75 \text{ N}$$

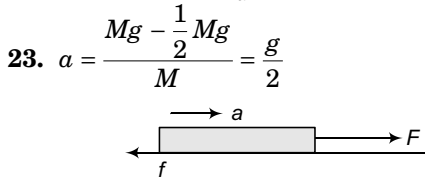

$$T - \frac{1}{2} \times \frac{M}{2} \times g = \frac{M}{2} \times a = \frac{Mg}{4}$$

$$\therefore T = \frac{Mg}{2}$$

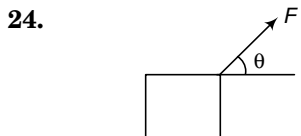

$$N = mg - F \sin \theta$$

$$F \cos \theta = \mu N = \mu (mg - F \sin \theta)$$

$$F = \frac{\mu mg}{\cos \theta + \mu \sin \theta}$$

$$\text{For } F \text{ to be minimum, } \frac{dF}{d\theta} = 0$$

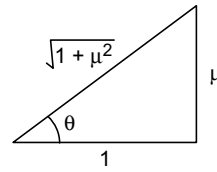

$$\text{or } \tan \theta = \mu$$

$$F_{\min} = \frac{\mu mg}{\frac{1}{\sqrt{1+\mu^2}} + \frac{\mu^2}{\sqrt{1+\mu^2}}}$$

$$= \frac{\mu}{\sqrt{1+\mu^2}} mg$$

$$= \frac{1}{2} mg$$

25. $\mu mg = 32 \text{ N}$

Since $\therefore f = 30 \text{ N}$

$$30 \text{ N} > \mu mg$$

$$\therefore \text{Normal reaction } N = mg = 40 \text{ N}$$

$$\therefore \text{Net contact force} = \sqrt{(30)^2 + (40)^2}$$

$$= 50 \text{ N}$$

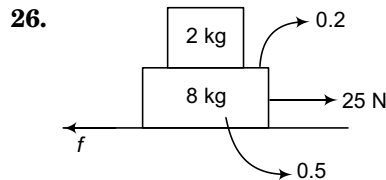

$$f_{\max} = (0.5)(8 + 2)(10) = 50 \text{ N} > 25 \text{ N}$$

\therefore Blocks will not move and therefore force of friction between two blocks = 0.

27. $mg \sin \theta = 10 \times 10 \times \frac{3}{5} = 60 \text{ N}$

This $60 \text{ N} > 30 \text{ N}$

\therefore Force of friction is upwards.

Net contact force is resultant of friction and normal reaction.

28. In first figure $T = F$

and in second figure, $T = 2F$.

29. $F = 4 \left(\frac{mg}{2} \right) \rightarrow \text{upwards}$

$$W = 2mg \rightarrow \text{downwards}$$

$$F = W$$

$$\therefore a = 0$$

30.

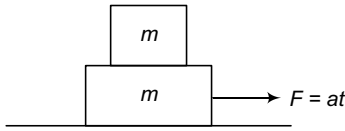

Maximum acceleration of upper block due to friction

$$a_{\max} = \frac{\mu mg}{m} = \mu g$$

$$\frac{F}{2m} = \frac{at}{2m} = \mu g$$

$$\therefore t = \frac{2\mu m g}{a}$$

31. $a_1 = g \sin 30^\circ = g/2$

$$a_2 = g \sin 60^\circ = \frac{\sqrt{3}}{2} g$$

Angle between \vec{a}_1 and \vec{a}_2 is 30° .

$$\therefore a_r = |\vec{a}_1 - \vec{a}_2| = \sqrt{\frac{(g/2)^2 + (\sqrt{3}g/2)^2 - 2(g/2)(\sqrt{3}g/2)\cos 30^\circ}{}} = g/2$$

JEE Corner

Assertion and Reason

1. Even if net force = 0, rotational motion can take place.
2. No solution is required.
3. $a_1 = g \sin \theta + \mu g \cos \theta$

$$a_2 = g \sin \theta - \mu g \cos \theta$$

$$\frac{a_1}{a_2} = \frac{1 + \mu}{1 - \mu} \text{ as } \theta = 45^\circ \text{ and } \sin \theta = \cos \theta$$

Substituting $\mu = \frac{1}{3}$ we have,

$$\frac{a_1}{a_2} = \frac{1 + 1/3}{1 - 1/3} = \frac{2}{1}$$

4. There is no force for providing $(-2 \hat{i}) \text{ m/s}^2$ to the block.
5. If we increase F_1 , maximum value of friction will increase. But if we increase F_2 friction acting on the block will increase.
6. No solution is required.
7. $a = \frac{(m_1 - m_2)g}{m_1 + m_2}$ (if $m_1 > m_2$)

$$m_1 g - T = m_1 a$$

$$\therefore T = m_1(g - a) = \frac{2m_1 m_2 g}{(m_1 + m_2)}$$

Mathematically, we can prove that

$$m_2 g < T < m_1 g$$

Similarly if $m_2 > m_1$, then we can prove that,

$$m_1 g < T < m_2 g$$

8. If accelerations of both the frames are same then one frame as observed from other frame will be inertial. Further, a frame moving with constant velocity is inertial.
9. No solution is required.
10. No solution is required.
11. Force of friction is in the direction of motion.

Objective Questions (Level 2)

Single Correct Option

1. $T_{\max} = F_{\max} + f_{\max} + 2T'_{\max}$

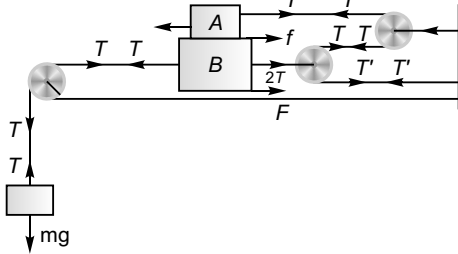

$$= \mu (m_A + m_B)g + \mu m_A g + 2\mu m_A g$$

$$= \mu (4m_A + m_B)g$$

But, $T_{\max} = M_{\max} \cdot g$

$$\therefore M_{\max} \cdot g = \mu (4m_A + m_B)g$$

i.e., $M_{\max} = \mu (4m_A + m_B)$
 $= 0.3 \times [(4 \times 100) + 70] = 81 \text{ kg}$

Option (c) is correct.

2. $\vec{v} = 8t \hat{i} - 2t^2 \hat{j}$

$$\therefore \vec{a} = \frac{d\vec{v}}{dt}$$

$$= 8 \hat{i} - 4t \hat{j}$$

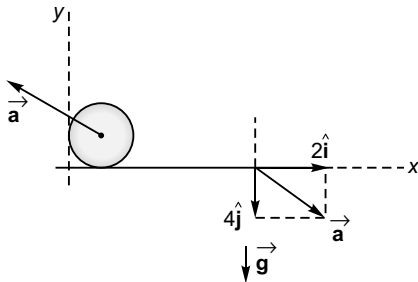

\therefore Force (pseudo) on sphere

$$\vec{F}_s = 1 \cdot (-8 \hat{i} + 4 \hat{j})$$

$$= -8 \hat{i} + 4 \hat{j}$$

Gravitational force on sphere

$$= -mg \hat{j} = -10 \hat{j}$$

\therefore Net force on sphere

$$\vec{F} = -8 \hat{i} + 4 \hat{j} - 10 \hat{j} = -8 \hat{i} - 6 \hat{j}$$

$$|\vec{F}| = 10 \text{ N}$$

Option (b) is correct.

3. $N \sin \theta$ will accelerate B towards left.

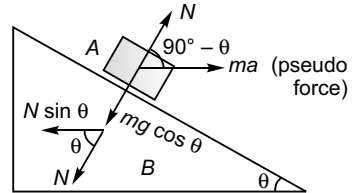

Let a be the acceleration of B.

Due to acceleration of B towards left pseudo force equal to ma will act on block, toward right.

$$\text{Thus, } N + ma \sin \theta = mg \cos \theta$$

$$\Rightarrow N = mg \cos \theta - ma \sin \theta$$

Option (b) is correct.

4. If $a \leq \mu g$

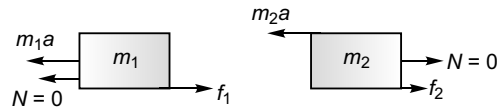
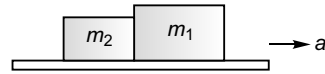

When a is	f_1	N	f_2
Zero	Zero	Zero	Zero
$\frac{\mu g}{2}$	$m_1 \frac{\mu g}{2}$	Zero	$m_2 \frac{\mu g}{2}$
μg	$m_1 \mu g$ (Not yet attained limiting value which is $2\mu m_1 g$)	Zero	$m_2 \mu g$ (Attained limiting value)

Now, if $a > \mu g$, the block of mass m_2 would be just greater like to move towards left than μg as a then

$$m_2 a > f_2 \quad (\text{max})$$

While the block of mass m_1 will remain at rest as then f_1 has margin to increase.

Thus, m_1 will apply normal force (N) or m_2 and so will do m_1 on m_2 to stop its motion (towards left).

Option (d) is correct.

5. $N + ma \sin \theta = mg \cos \theta$

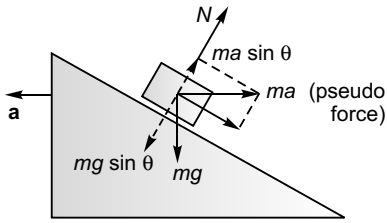

The block will fall freely if $N = 0$

i.e., $ma \sin \theta = mg \cos \theta$

$\Rightarrow a = g \cos \theta$

Option (c) is correct.

6. Speed of A w.r.t. C = v_1

Speed of C w.r.t. ground = v_0

\therefore Speed of A w.r.t. ground = $v_1 - v_0$

Now, speed of B w.r.t. ground = speed of A is w.r.t. ground

$\therefore v_2 = v_1 - v_0$

$\Rightarrow v_1 - v_2 = v_0$

Option (a) is correct.

7. Fig. 1

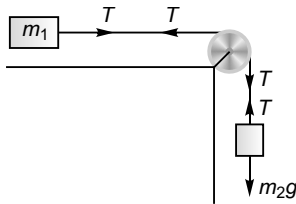

$m_2g - T = m_2a_1$

and

$a_1 = \frac{m_2}{m_1 + m_2} g$

Fig. 2

$m_1g - T = m_2a_2$

and

$T - m_2g = m_1a_2$

\Rightarrow

$a_2 = \frac{m_1 - m_2}{m_1 + m_2} g$

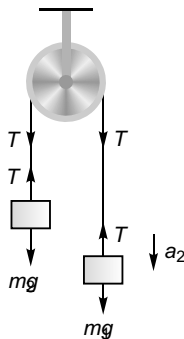
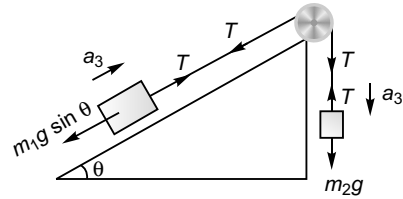

Fig. 3



$m_2g - T = m_2a_3$

and

$T - m_1g \sin \theta = m_1a_3$

\therefore

$a_3 = \frac{m_2 - m_1 \sin \theta}{m_1 + m_2} g$

Substituting $m_1 = 4 \text{ kg}$, $m_2 = 3 \text{ kg}$

and

$\theta = 30^\circ$

$a_1 = \frac{3}{4 + 3} g$

$= \frac{3}{7} g$

$a_2 = \frac{4 - 3}{4 + 3} g$

$= \frac{1}{7} g$

$a_3 = \frac{3 - 4^2 \cdot \frac{1}{2}}{4 + 3} g$

$= \frac{1}{7} g$

\therefore

$a_1 > a_2 = 3$

Option (b) is correct.

8. $F - f_{\max} - T = ma$ (For lower block)

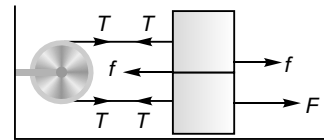

$T - f_{\max} = ma$ (For upper block)

$\Rightarrow F - 2f_{\max} = 2ma$

or $F - 2\mu mg = 2ma$

or $a = \frac{F}{2m} - \mu g$

Option (c) is correct.

9. $a_2 \cos(90^\circ - \theta) = a_1$

i.e., $a_2 \sin \theta = a_1$ [$\theta < 0^\circ$]

Option (b) is correct.

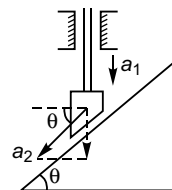

10. Had θ been 90° .

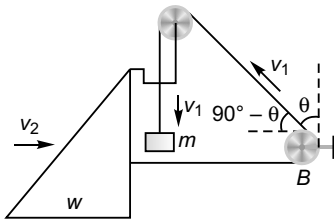

For every x displacement of wedge (w) the vertical fall in mass would have been $2x$ as the string passes through pulley B .

i.e., $v_1 = 2v_2$

For the situation given the speed of mass would thus be

$$v_1 = 2v_2 \cos(90^\circ - \theta)$$

i.e., $v_1 = 2v_2 \sin \theta$

Option (c) is correct.

11. The cylinder will start rising up the inclined plane if

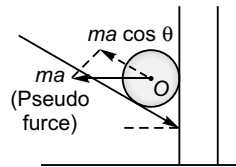

$$ma \cos \theta > mg \sin \theta$$

i.e., $a > g \tan \theta$

$\therefore a_{\min} = g \tan \theta$ [cylinder will be at the point of rising up the inclined plane]

12. At the position of maximum deflection the net acceleration of bob (towards its mean position will be)

$$g \sin \theta - a \cos \theta$$

as explained in figure.

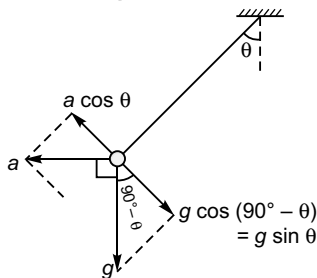

13. $Mg - T = Ma$
 $T - mg = ma$

$$\Rightarrow a = \frac{M - m}{M + m} g$$

$$\begin{aligned} \therefore T &= m(g + a) \\ &= m \left[g + \frac{M - m}{M + m} g \right] \\ &= mg \left[1 + \frac{M - m}{M + m} \right] \\ &= mg [1 + 1] \end{aligned}$$

[as $m \ll M$, $M - m \approx M$ and $M + m \approx M$]

$$= 2mg$$

\therefore Tension in the string suspended from ceiling = $2T = 4mg$

Option (a) is correct.

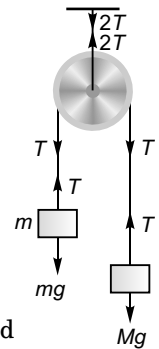

14. For $0^\circ < \theta \leq \phi$ frictional force (F) = $mg \sin \theta$
For $\theta \geq \phi$ frictional force (F) = $\mu mg \cos \theta$
[ϕ = angle of repose]

For example

$$\text{Let } \mu = \frac{1}{\sqrt{3}} \quad \therefore \tan \phi = \frac{1}{\sqrt{3}}$$

$$\phi = 30^\circ$$

θ	F (force of friction)	Condition
10°	$mg \sin 10^\circ = 0.174 mg$	Increase but not linearly only
20°	$mg \sin 20^\circ = 0.342 mg$	
30°	$\mu mg \cos 30^\circ = 0.500 mg$	
40°	$\mu mg \cos 40^\circ = 0.442 mg$	Decrease but not linearly only
60°	$\mu mg \cos 60^\circ = 0.287 mg$	
90°	Zero	

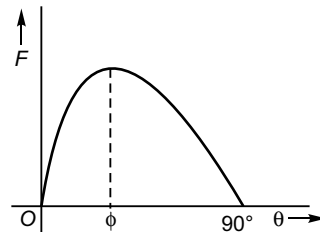

Option (b) is correct.

15. $a_B = \frac{\mu mg}{2m}$
 $= \frac{\mu g}{2}$

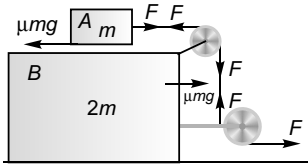

For no slipping

$$\frac{F - \mu mg}{m} = \frac{\mu g}{2}$$

i.e., $F = \frac{3}{2} \mu mg$

$$\mu = \frac{2}{3} \frac{F}{mg}$$

Slipping will obviously be m_2 there if μ is greater than above mentioned value

$$\therefore \mu_{\min} = \frac{2}{3} \frac{F}{mg}$$

For no slipping.

Option (c) is correct.

16. F_{net} (downward) = $mg \sin \theta + ma \cos \theta$

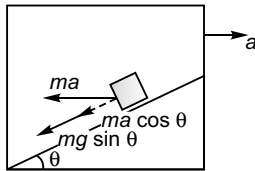

$$= m(g \sin \theta + a \cos \theta)$$

$$\therefore g_{\text{eff}} = g \sin \theta + a \cos \theta$$

Time (T) required to cover $2L$ distance along inclined would be

$$T = \sqrt{\frac{2L}{g_{\text{eff}}}}$$

$$= \sqrt{\frac{2L}{(g \sin \theta + a \cos \theta)}}$$

Option (c) is correct.

17. F_{net} on block along incline in the upward direction

$$= ma \cos \theta - mg \sin \theta$$

$$= m(a \cos \theta - g \sin \theta)$$

$$\therefore g_{\text{eff}} = a \cos \theta - g \sin \theta$$

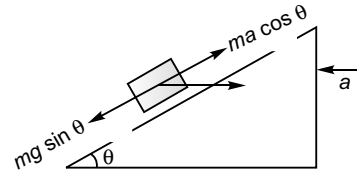

\therefore Time (t) to move s distance would be given by

$$s = \frac{1}{2} g_{\text{eff}} t^2$$

i.e., $t = \sqrt{\frac{2s}{g_{\text{eff}}}} = \sqrt{\frac{2s}{(a \cos \theta - g \sin \theta)}}$

Substituting $s = 1$ m,

$$\theta = 30^\circ,$$

$$a = 10\sqrt{3} \text{ m/s}^2 \text{ and } g = 10 \text{ m/s}^2$$

$$t = \sqrt{\frac{2 \times 1}{\left(10\sqrt{3} \times \frac{\sqrt{3}}{2}\right) - \left(10 \times \frac{1}{2}\right)}}$$

$$= \frac{1}{\sqrt{5}} \text{ s}$$

Option (b) is correct.

18. $N + \frac{w}{2} \sin 30^\circ = w + \frac{w}{2}$

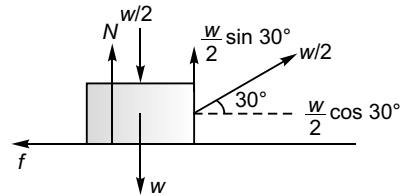

f = frictional force

$$N = \frac{5w}{4}$$

$$f_{\text{max}} = \mu N = \mu \cdot \frac{5w}{4}$$

The block will remain stationary if

$$\frac{w}{2} \cos 30^\circ \leq \mu \frac{5w}{4}$$

or $\frac{w}{2} \frac{\sqrt{3}}{2} \leq \mu \frac{5w}{4}$

or $\frac{\sqrt{3}}{5} \leq 5\mu$

or $\frac{\sqrt{3}}{5} \leq \mu$

\therefore Block will move if $\mu < \frac{\sqrt{3}}{5}$

Option (d) is correct.

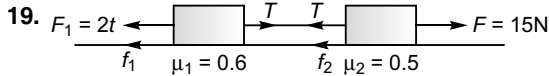

At $t = 2$ s
 $F_1 = 4$ N

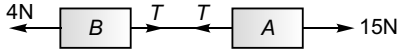

f_1 and f_2 are the frictional forces

$$(f_1)_{\max} = 0.6 \times 1 \times 10 = 6 \text{ N}$$

$$(f_2)_{\max} = 0.5 \times 2 \times 10 = 10 \text{ N}$$

At $t = 2$ s

$$\begin{aligned} \text{Net external force } (F_{\text{net}}) \text{ on system} \\ &= 15 \text{ N} - 4 \text{ N} \\ &= 11 \text{ N} \end{aligned}$$

As $F_{\text{net}} > (f_1)_{\max} + (f_2)_{\max}$, the system will remain at rest and the values frictional forces on the blocks will be given

$$\begin{aligned} T &= 4 + f_1 \text{ and } T = 15 - f_2 \\ 4 + f_1 &= 15 - f_2 \quad \dots(i) \\ f_1 + f_2 &= 11 \text{ N} \end{aligned}$$

Let direction being + ive for Eq. (i)

Option (a) $f_1 = -4$ N, $f_2 = +5$ N

$\Rightarrow f_1 + f_2 = 1$ N wrong

Option (b) $f_1 = -2$ N, $f_2 = +5$ N

$\Rightarrow f_1 + f_2 = 3$ N wrong

Option (c) $f_1 = 0$ N, $f_2 = +10$ N

$\Rightarrow f_1 + f_2 = 10$ N wrong

Option (d) $f_1 = +1$ N, $f_2 = +10$ N

$\Rightarrow f_1 + f_2 = 11$ N correct.

OR

As the likely movement would be towards right f_2 will be at its maximum.

$\therefore f_2 = 10$ N

$\Rightarrow f_1 = 1$ N

Option (d) is correct.

20. $2mg \sin \alpha - T = 2ma$

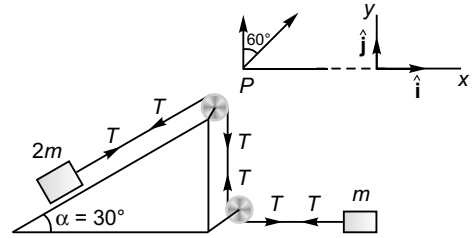

and $T = ma$
 $\therefore 2mg \sin \alpha = 3ma$
 $\Rightarrow a = \frac{2g \sin 30^\circ}{3} = \frac{g}{3}$
 $\therefore T = \frac{mg}{3}$

Force (R) applied by clamp on pulley would be

$$|\vec{T}_1| = |\vec{T}_2| = T$$

$$\begin{aligned} \vec{T}_1 &= \frac{mg}{3} (\cos 30^\circ) \hat{i} + \frac{mg}{3} (\sin 30^\circ) \hat{j} \\ &= \frac{mg\sqrt{3}}{6} \hat{i} + \frac{mg}{6} \hat{j} \end{aligned}$$

$$|\vec{T}_2| = \frac{mg}{3} \hat{j}$$

Force by clamp on pulley P

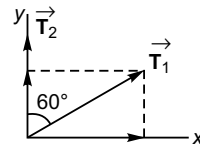

$$\begin{aligned} &= \vec{T}_1 + \vec{T}_2 \\ &= \frac{mg\sqrt{3}}{6} \hat{i} + \frac{mg}{6} \hat{j} + \frac{mg}{3} \hat{j} \\ &= \frac{mg\sqrt{3}}{6} \hat{i} + \frac{3mg}{6} \hat{j} = \frac{mg}{6} (\sqrt{3} \hat{i} + 3 \hat{j}) \end{aligned}$$

Option (b) is correct.

21. $f_1(\max) = 0.3 \times 4 \times 10 = 12$ N

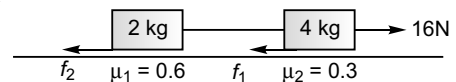

f_1 and f_2 are frictional forces.

$f_2(\max) = 0.6 \times 2 \times 10 = 12$ N

As, $f_1(\max) + f_2(\max) < 16$ N (F_{ext})

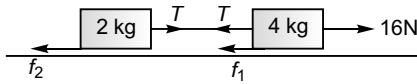

The system will remain at rest.
 For the equilibrium of 4 kg mass :
 $\therefore 16 = T + f_1 \quad \dots(i)$

As f_1 will be at its maximum value
 $f_1 = 12 \text{ N}$
 $\therefore T = 16 - 12 = 4 \text{ N [from Eq. (i)]}$

Further, for the equilibrium of 2 kg mass.
 $T = f_1$
 $\therefore f_1 = 4 \text{ N}$

Option (c) is correct.

22. For the rotational equilibrium of rod
 Taking moment about O.

$$R \times \frac{l}{2} \cos \theta = s \frac{l}{2} \sin \theta$$

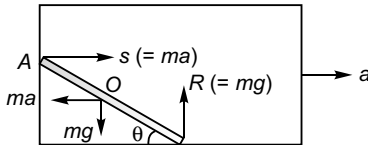

or $mg \cos \theta = ma \sin \theta$
 $\Rightarrow a = g \cot \theta$

Option (d) is correct.

23. $v = 2t^2$
 $\therefore a = \frac{dv}{dt} = \frac{d}{dt}(2t^2) = 4t$

At $t = 1 \text{ s}$, $a = 4 \text{ ms}^{-2}$
 As $a = \mu_s g$
 $\mu_s = \frac{a}{g} = \frac{4}{10} = 0.4$

Option (c) is correct.

24. Just at the position of tipping off, R_1 will be zero.

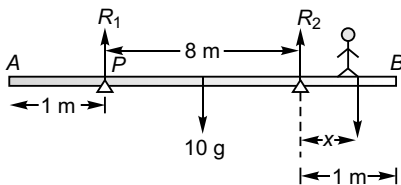

\therefore Taking moment about point Q
 $(10g)(4) = (80g)(x)$

$$\therefore x = \frac{1}{2} \text{ m}$$

Option (a) is correct.

25. $N = ma \sin \theta + mg \cos \theta \quad \dots(i)$

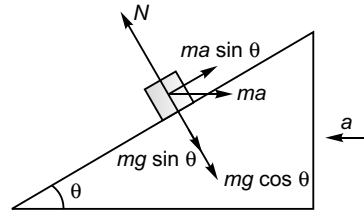

Now, as the block does not slide
 $ma \cos \theta = mg \sin \theta$

i.e.,

$$a = g \tan \theta$$

Substituting the found value of a in Eq. (i)

$$N = m(g \tan \theta) \sin \theta + mg \cos \theta = mg \left[\frac{\sin^2 \theta}{\cos} + \cos \theta \right] = mg \sec \theta$$

When, the block stops $a = 0$, the value of normal force will be

$$N' = mg \cos \theta$$

$$\therefore \frac{N'}{N} = \frac{mg \cos \theta}{mg \sec \theta}$$

Option (c) is correct.

26. For the rotational equilibrium of the block

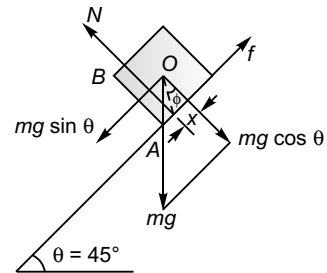

Taking moment about O.

$$Nx = f \frac{a}{2}$$

or $(mg \cos \theta) x = (mg \sin \theta) \frac{a}{2}$

or $x = \frac{a}{2} \tan \theta$

or $\frac{x}{a/2} = \tan \theta$

or $\tan \phi = \tan \theta$

or $\phi = \theta$

Thus, the normal force (N) will pass through point A.

Option (a) is correct.

[Note : The cube will be just at the point of tilting (about point A). The cube will tilt if θ is made greater than 45°].

27. For the rotational equilibrium of the cube
Moment of couple (N, mg)

= Moment of couple (F, f)

$$\therefore mgx = Fa$$

$$\text{or } mgx = \frac{mg}{3} \cdot a$$

$$\text{i.e., } x = \frac{a}{3}$$

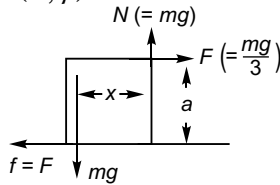

Option (b) is correct.

28. Taking moment about point O.

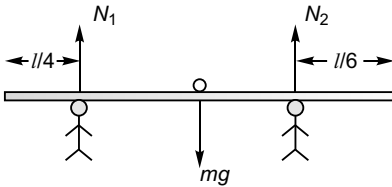

$$N_1 \left(\frac{l}{2} - \frac{l}{4} \right) = N_2 \left(\frac{l}{2} - \frac{l}{6} \right)$$

$$N_1 \frac{l}{4} = N_2 \frac{l}{3}$$

$$\therefore N_1 : N_2 = 4 : 3$$

Option (c) is correct.

29.

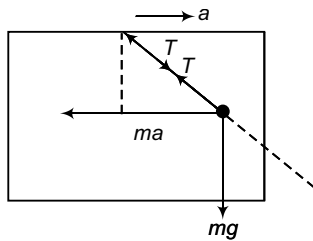

$$(T / \sqrt{2}) = ma \rightarrow \text{Box}$$

$$T + \frac{ma}{\sqrt{2}} = \frac{mg}{\sqrt{2}} \rightarrow \text{Pendulum with}$$

respect to

box

$$\therefore \sqrt{2}ma + \frac{ma}{\sqrt{2}} = \frac{mg}{\sqrt{2}}$$

$$\therefore a = g / 3$$

30.

$$N \sin \theta = m_B a_B \quad \dots(i)$$

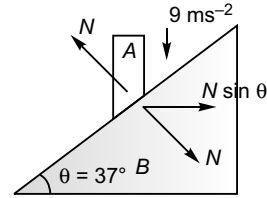

$$a_A = a_B \tan \theta \quad \dots(ii)$$

$$\Rightarrow N \sin \theta = m_B \frac{a_A}{\tan \theta}$$

$$N = \frac{m_B a_A}{\sin \theta \tan \theta}$$

\therefore Force on rod by wedge

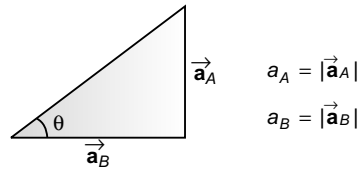

$$a_A = |\vec{a}_A|$$

$$a_B = |\vec{a}_B|$$

$$N \cos \theta = \frac{m_B a_A \cos \theta}{\sin \theta \tan \theta}$$

$$= \frac{m_B a_A}{\tan^2 \theta}$$

$$= \frac{10 \times 9}{\left(\frac{3}{4}\right)^2} = 160 \text{ N}$$

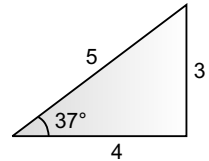

Option (c) is correct.

31. Net downward force on ring = $mg - \mu ma$
= $m(g - \mu a)$

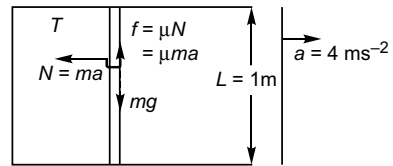

\therefore

$$g_{\text{eff}} = g - \mu a$$

$$t = \sqrt{\frac{2L}{g_{\text{eff}}}}$$

$$= \sqrt{\frac{2L}{g - \mu a}}$$

$$= \sqrt{\frac{2 \times 1}{10 - (0.5 \times 4)}}$$

$$= \frac{1}{2} = 0.5 \text{ s}$$

32. The direction of the normal reactions between any one hemisphere and the sphere will be along the centres of the two. The three centres of the hemisphere and that of sphere will form a tetrahedron of edge equal to $2R$.

In figure, C_1, C_2 and C_3 are the centres of the hemispheres and C is the centre of the sphere

$$C_1C_2 = C_2C_3 = C_3C_1 = C_1C = C_2C = C_3C = 2R$$

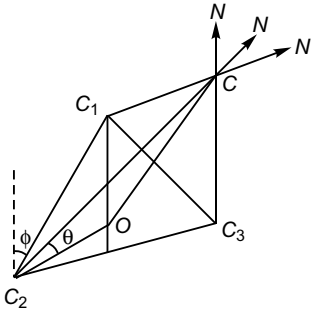

$$\begin{aligned} \angle COC_2 &= 90^\circ \\ C_2O &= \frac{2R}{\sqrt{3}} \\ \cos \theta &= \frac{C_2O}{C_2C} \\ &= \frac{2R/\sqrt{3}}{2R} \\ &= \frac{1}{\sqrt{3}} \end{aligned}$$

ϕ is the angle which any N makes with vertical

$$\begin{aligned} \phi &= 90^\circ - \theta \\ \sin \phi &= \cos \theta = \frac{1}{\sqrt{3}} \\ \therefore \cos \phi &= \frac{2}{\sqrt{3}} \end{aligned}$$

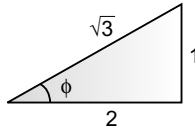

For the vertical equilibrium of the sphere.

$$\begin{aligned} 3N \cos \phi &= mg \\ \text{or } 3N \times \frac{2}{\sqrt{3}} &= mg \\ \text{or } N &= \frac{mg}{2\sqrt{3}} \end{aligned}$$

Option (b) is correct.

33. $T - Mg = Ma$

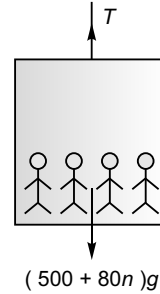

$$\begin{aligned} \text{i.e., } T &= M(g + a) \\ \therefore 2 \times 10^4 &\geq M(g + a) \\ \text{or } 2 \times 10^4 &\geq (500 + 80n)(10 + 2) \\ \text{or } 14.58 &\geq n \\ \text{or } n &= 14 \end{aligned}$$

Option (b) is correct.

[Note : Tension in lift cable will increase when the lift is accelerated upwards].

34. Normal reaction between the surface and the particle will be zero throughout the motion if the path of the particle is that of a projectile motion (particle is free from surface).

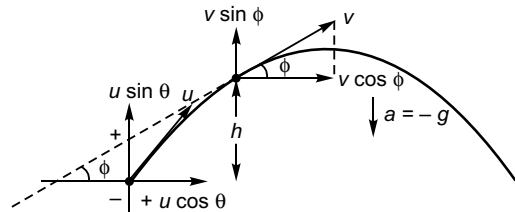

$$\begin{aligned} v^2 &= u^2 + 2as \\ (v \sin \phi)^2 &= (u \sin \theta)^2 + 2(-g)h \\ v \sin \phi &= \sqrt{u^2 \sin^2 \theta - 2gh} \\ &= \sqrt{(20)^2 (\sin^2 60^\circ) - 2 \cdot 10 \cdot 5} \\ &= \sqrt{\left(400 \times \frac{3}{4}\right) - 100} \\ &= 10\sqrt{2} \\ v \cos \phi &= u \cos \theta = 20 \cos 60^\circ = 10 \\ \frac{v \sin \phi}{v \cos \phi} &= \frac{10\sqrt{2}}{10} \end{aligned}$$

$$\tan \phi = \sqrt{2}$$

$$\phi = \tan^{-1} \sqrt{2}$$

Option (c) is correct.

35. Acceleration of block B will be g throughout its motion while that of block A will increase from 0 to g and as such

$$t_A < t_B$$

Option (b) is correct.

36. $f_1(\text{max}) = 0.5 \times 10 \times 10 = 50 \text{ N}$

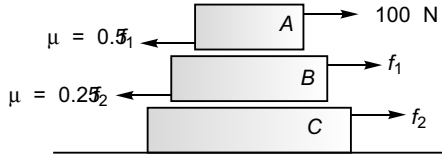

Here, f_1 and f_2 are friction forces.

As, $f_1(\text{max.}) < F_{\text{ext.}}(100 \text{ N})$, block A will move.

$$f_2(\text{max.}) = 0.25(10 + 20)10 = 75 \text{ N}$$

As, $f_1(\text{max.})$, [driving force for block B] $< f_2(\text{max.})$, the block will not slip over block C.

As, there is no friction between block C and surface below it, both the blocks B and block C will move together with acceleration

$$a = \frac{f_1(\text{max.})}{(\text{mass of } B + C)}$$

$$= \frac{50}{(20 + 30)}$$

$$= 1 \text{ ms}^{-2}$$

$$\therefore a_A = 1 \text{ ms}^{-2}$$

Option (c) is correct.

37. $\cos \theta = \frac{R - \frac{R}{5}}{R} = \frac{4}{5}$

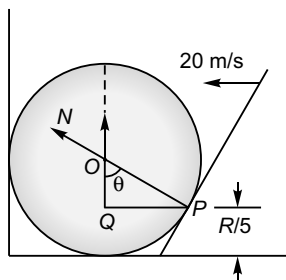

Velocity along $PQ = 20 \text{ m/s}$.

$$\therefore \text{Velocity along } PO = 20 \sin \theta$$

$$= 20 \times \frac{3}{5} = 12 \text{ m/s}$$

Velocity of sphere (along vertical direction)

$$= \frac{12}{\cos \theta} = \frac{12}{4/5} = 15 \text{ m/s}$$

Option (c) is correct.

38. String is winding on the motor shaft the block B will move up. Further, as shaft is also moving down, B will further.

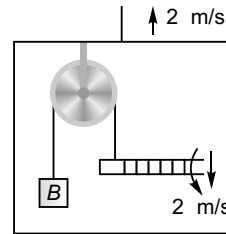

Thus,

Velocity of block B

= Velocity of lift + Velocity of winding of string on shaft + Velocity of moving down of shaft

$$q = 2 \text{ m/s} + 2 \text{ m/s} + 2$$

m/s

$$= 6 \text{ m/s.}$$

Option (d) is correct.

39. $F'' = F' \cos \theta$

F is resultant of two equal forces F' and F'

$$F = 2F' \cos \left(\frac{2\phi}{2} \right)$$

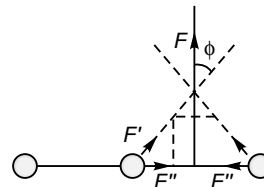

$$= 2F' \cos \phi$$

$$= 2F' \cos (90^\circ - \theta)$$

$$= 2F' \sin \theta$$

$$= 2 \left(\frac{F''}{\cos \theta} \right) \sin \theta$$

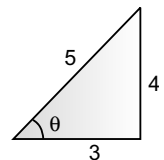

$$\begin{aligned}
 &= 2F'' \tan \theta \\
 &= 2(ma'') \tan \theta \\
 &= 2 \times 0.3 \times \frac{5}{2} \times \frac{4}{3} = 2 \text{ N}
 \end{aligned}$$

Option (b) is correct.

40. Velocity of block A = $2v \cos 37^\circ$

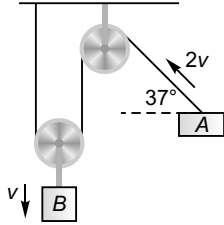

$$\begin{aligned}
 &= 2 \times 10 \times \frac{4}{5} \\
 &= 16 \text{ m/s}
 \end{aligned}$$

Option (d) is correct.

41. As the mass is applying maximum possible force without moving, the blocks would be at the point of slipping,

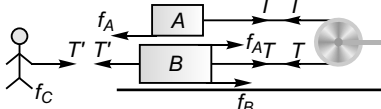

$$\begin{aligned}
 T' = f_C (\text{max}) &= 0.5 \times 60 \times 10 = 300 \text{ N} \\
 f_B (\text{max}) &= 0.3 \times (60 + 60) \times 10 \\
 &= 360 \text{ N}
 \end{aligned}$$

As, $T' < f_B (\text{max})$ the value of T will be zero.

Option (d) is correct.

[Note : The value f_B will be 300 N and the values of T and f_A will be zero]

42. $\vec{a}_A = |5\hat{i} + 15\hat{j}|$

$\therefore \theta = 45^\circ$

As, $\phi < \theta$ the block will leave contact with B.

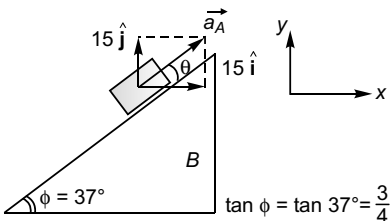

For A to remain in contact with B, B must accelerate in the -ive x-direction.

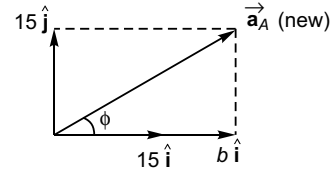

Let acceleration of B = $-b\hat{i}$

Due to this pseudo force with act on A in the +ive direction.

$$\tan \phi = \frac{15}{15 + b}$$

or $\frac{3}{4} = \frac{15}{15 + b}$

or $45 + 3b = 60$

or $3b = 15$

or $b = 5$

\therefore Acceleration of B = $-5\hat{i}$

Option (d) is correct.

43. For block A not to slide on block B

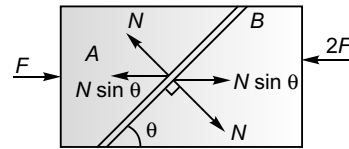

F_{net} on block A = F_{net} on block B

$$F - N \sin \theta = N \sin \theta - 2F$$

$$2N \sin \theta = 3F$$

$$N = \frac{3F}{2 \sin \theta}$$

$$= 3F \quad (\text{as } \theta = 30^\circ)$$

Option (d) is correct.

44. Equation to circle is

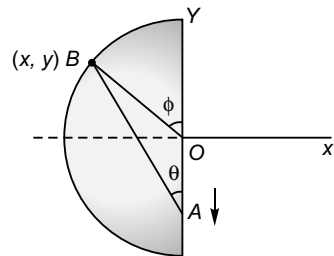

$$x^2 + y^2 = r^2 \text{ (where } r = OB) \quad \dots(i)$$

$$\therefore 2 \frac{dx}{dt} + 2 \frac{dy}{dt} = 0$$

$$\Rightarrow \frac{dx}{dt} = - \frac{dy}{dt}$$

$$= -(-u) = +u$$

$$= u$$

Speed of bead B

$$= \sqrt{\left(\frac{dx}{dt}\right)^2 + \left(\frac{dy}{dt}\right)^2}$$

$$= \sqrt{(u)^2 + (-u)^2}$$

$$= u\sqrt{2}$$

Option (a) is correct.

45. At maximum acceleration value of a , the block would be in a position to move upwards.

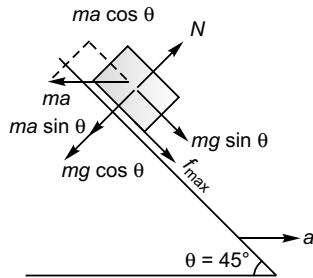

f = frictional force

$$N = ma \sin \theta + mg \cos \theta$$

$$ma \cos \theta = f_{\max} + mg \sin \theta$$

or $ma \cos \theta = \mu N + mg \sin \theta$

or $ma \cos \theta = \mu (ma \sin \theta + mg \cos \theta) + mg \sin \theta \quad (\because \theta = 45^\circ)$

or $a = \mu (a + g) + g$

or $a(1 - \mu) = (1 + \mu)g$

i.e., $a = \frac{1 + \mu}{1 - \mu} g$

Option (b) is correct.

46. For the beam to have no tendency to rotate

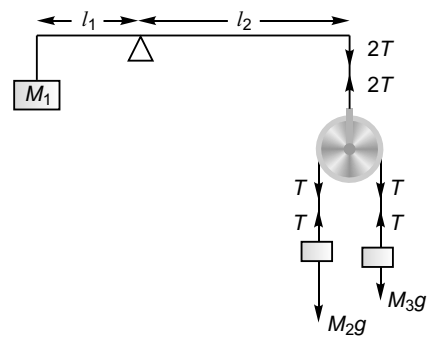

$$M_1 g l_1 = 2 T l_2$$

or $M_1 g l_1 = 2 \left(\frac{2 M_1 M_3}{M_2 + M_3} g \right) l_2$

or $M_1 l_1 = 4 \left(\frac{M_2 \cdot \frac{M_2}{3}}{M_2 + \frac{M_2}{3}} \right) 3 l_2$

$$\Rightarrow \frac{M_1}{M_2} = 3$$

47. $f_{\max} = \mu_k N \sqrt{2}$

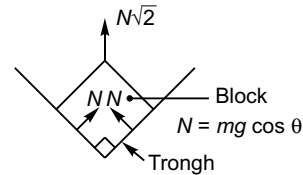

$$= \mu_k \sqrt{2} mg \cos \theta$$

$$\therefore ma = mg \sin \theta - \sqrt{2} \mu_k mg \cos \theta$$

i.e., $a = g (\sin \theta - \sqrt{2} \mu_k \cos \theta)$

Option (c) is correct.

48. $f_1 (\max) = 0.5 \times 3 \times 10 = 15 \text{ N}$

$$f_2 (\max) = 0.3 \times (3 + 2) \times 10 = 15 \text{ N}$$

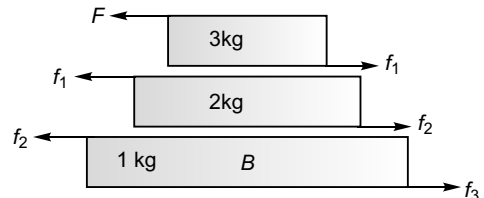

$$f_3 (\max) = 0.1 \times (3 + 2 + 1) \times 10 = 6 \text{ N}$$

Value of maximum frictional force is between block 1 kg and the ground. Increasing from zero when F attains 6 N, the block of mass 1 kg will be at the point of slipping over ground below it.

Option (c) is correct.

49. $f_2 \text{ (max)} = \mu (m_1 + m_2) g$

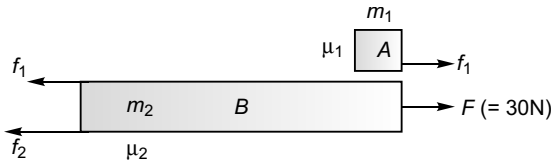

$$= 0.5(1 + 2) 10$$

$$= 15 \text{ N}$$

a_S = Acceleration of both as one

a_A = Acceleration of A

$$f_1 \text{ (max)} = \mu_1 m_1 g = 0.2 \times 1 \times 10$$

$$= 2 \text{ N}$$

$$a_S = \frac{F - f_2 \text{ (max)}}{m_1 + m_2} = \frac{30 - 15}{3} = 5 \text{ m/s}^2$$

$$a_A = \frac{\mu_1 m_1 g}{m_1} = \mu_1 g = 0.2 \times 10 = 2 \text{ m/s}^2$$

As, $F > f_2 \text{ (max.)}$

both will move.

Further, as $a_S > a_A$ both will not accelerate as one unit.

$$a_B = \frac{F - \mu_2 (m_1 + m_2) g - \mu_1 m_1 g}{m_2}$$

Acceleration of A w.r.t. B

$$a_{AB} = a_A - a_B$$

$$= \mu_1 g - \frac{f - \mu_2 (m_1 + m_2) g - \mu_1 m_1 g}{m_2}$$

$$= - \frac{\mu_1 m_2 g - F + \mu_2 (m_1 + m_2) g + \mu_1 m_1 g}{m_2}$$

$$= - \frac{F - (\mu_1 + \mu_2) (m_1 + m_2) g}{m_2}$$

$$= - \frac{30 - (0.2 + 0.5) (1 + 2) 10}{2}$$

$$= - \frac{9}{2} \text{ m/s}^2$$

Negative sign indicates that the direction of a_{AB} will be opposite to that of a_A .

$$\therefore \text{Required time } t = \sqrt{\frac{2s}{a_{AB}}} = \sqrt{\frac{2 \cdot 1}{9/2}} = \frac{2}{3} \text{ s}$$

Option (a) is correct.

50. $F = \mu_s mg \cos \theta - mg \sin \theta$

$$= mg \left[\frac{4}{3\sqrt{3}} \frac{\sqrt{3}}{2} - \frac{1}{2} \right]$$

$$= \frac{mg}{6}$$

Option (b) is correct.

51. $\mu_s = 2\mu_k$

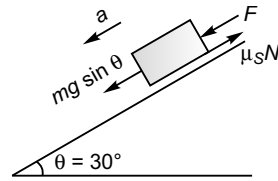

Force required to just slide block downwards

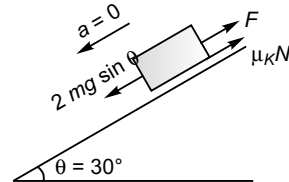

$$F = \mu_s N - mg \sin \theta$$

$$= \mu_s mg \cos \theta - mg \sin \theta$$

$$F = mg \sin \theta - \mu_k N$$

$$= mg \sin \theta - \mu_k mg \cos \theta$$

Thus, $\mu_s mg \cos \theta - mg \sin \theta$

$$= mg \sin \theta - \mu_k mg \cos \theta$$

$$(\mu_s + \mu_k) mg \cos \theta = 2mg \sin \theta$$

$$\left(\mu_s + \frac{\mu_s}{2} \right) = 2 \tan \theta$$

$$\frac{3}{2} \mu_s = \frac{2}{\sqrt{3}} \Rightarrow \mu_s = \frac{4}{3\sqrt{3}}$$

Option (a) is correct.

52. $a = \frac{F + mg \sin \theta - \mu_k mg \cos \theta}{m}$

$$= \frac{\frac{mg}{6} + \frac{mg}{2} - \frac{2}{3\sqrt{3}} \cdot mg \frac{\sqrt{3}}{2}}{m}$$

$$= \frac{g}{3}$$

Option (d) is correct.

53. Minimum force required to start the motion upward

$$\begin{aligned}
 &= mg \sin \theta + \mu_k mg \cos \theta \\
 &= mg \left[\frac{1}{2} + \frac{4}{3\sqrt{3}} \cdot \frac{\sqrt{3}}{2} \right] \\
 &= \frac{7}{6} mg
 \end{aligned}$$

54. Minimum force required to move the block up the incline with constant speed

$$\begin{aligned}
 &= mg \sin \theta + \mu_k mg \cos \theta \\
 &= mg \left[\frac{1}{2} + \frac{2}{3\sqrt{3}} \cdot \frac{\sqrt{3}}{2} \right] \\
 &= \frac{5}{6} mg
 \end{aligned}$$

55. $S_1 = \frac{(5.22)^2}{2 \cdot \left(\frac{9.8}{8}\right)} = 14.3 \text{ m}$

Option (c) is correct.

56. $a' = \frac{1200g - 1000g}{1200} = \frac{g}{6}$

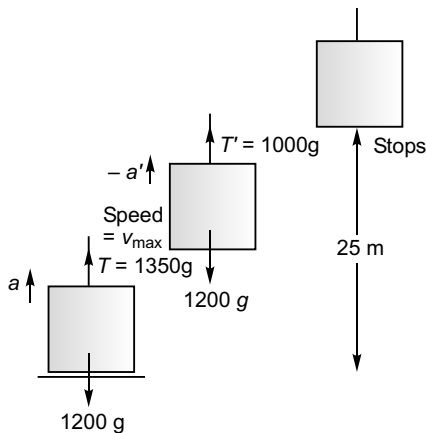

$$\begin{aligned}
 a &= \frac{1350g - 1200g}{1200} \\
 &= \frac{g}{8}
 \end{aligned}$$

For accelerated motion

$$\begin{aligned}
 v_{\max}^2 &= 0^2 + 2as_1 \\
 \Rightarrow s_1 &= \frac{v_{\max}^2}{2a}
 \end{aligned}$$

For retarded motion

$$\begin{aligned}
 0^2 &= v_{\max}^2 - 2a's_2 \\
 \Rightarrow s_2 &= \frac{v_{\max}^2}{2a'} \\
 s_1 + s_2 &= \frac{v_{\max}^2}{2} \left[\frac{1}{a} + \frac{1}{a'} \right] \\
 25 &= \frac{v_{\max}^2}{2} \left[\frac{8}{g} + \frac{6}{g} \right] \\
 v_{\max} &= \sqrt{\frac{50 \times 9.8}{14}} = 5.92 \text{ ms}^{-1}
 \end{aligned}$$

Option (c) is correct.

57. $mg \sin \theta = 170 \times 10 \times \frac{8}{15} = 906.67 \text{ N}$

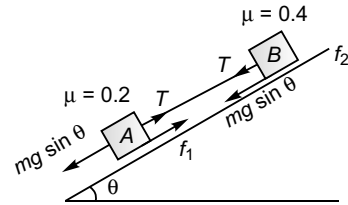

$$\begin{aligned}
 f_1 (\text{max}) &= 0.2 \times 170 \times 10 \times \frac{15}{17} = 300 \text{ N} \\
 f_2 (\text{max}) &= 0.4 \times 170 \times 10 \times \frac{15}{17} \\
 &= 600 \text{ N}
 \end{aligned}$$

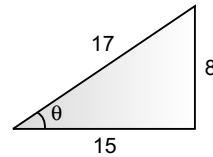

The whole system will accelerate as $mg \sin \theta$ is greater than both $f_1 (\text{max})$ and $f_2 (\text{max})$.

Total force of friction

$$\begin{aligned}
 &= f_1 (\text{max}) + f_2 (\text{max}) \\
 &= 900 \text{ N}
 \end{aligned}$$

Option (a) is correct.

58. $mg \sin \theta - 300 - T = ma$... (i)

and $mg \sin \theta + T = ma$... (ii)

Substituting Eq. (i) by Eq. (ii),

$$2T + 300 = 0$$

$$T = -150 \text{ N}$$

$$= 150 \text{ N, compressive.}$$

Option (a) is correct.

More than One Correct Options

1. (a) Normal force between A and B = m_2g

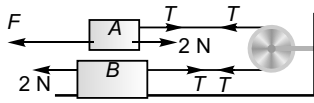

$$= 1 \times 10 = 10 \text{ N}$$

\therefore Force of limiting friction by B on A (or by A on B)

$$= \mu \times 10 = 2 \text{ N}$$

Total force opposing applied external force

$$\begin{aligned} F &= 2 \text{ N} + T \\ &= 2 \text{ N} + 2 \text{ N} \\ &= 4 \text{ N} \end{aligned}$$

Thus, if $F \leq 4 \text{ N}$

The block A will remain stationary and so block B also. The system will be in equilibrium.

\therefore Option (a) is correct.

(b) If $F > 4 \text{ N}$

$$F - T - 2 = 1a$$

$$\text{and } T - 2 = 1a \quad \dots(i)$$

Adding above equation

$$F - 4 = 2a \quad \dots(ii)$$

$$\text{i.e., } F = 4 + 2a$$

For $F > 4 \text{ N}$

$$2a + 4 > 4$$

$$\text{or } a > 0$$

$$\Rightarrow T - 2 > 0$$

$$\text{i.e., } T > 2 \text{ N}$$

\therefore Option (b) is incorrect.

(c) Block A will move over B only when $F > 4 \text{ N}$ and then the frictional force between the blocks will be 2 N if a is just 0 [as explained in (b)].

Option (c) is correct.

(d) If $F = 6 \text{ N}$ using Eq. (ii)

$$2a = 6 - 4$$

$$\Rightarrow a = 1 \text{ m/s}^2$$

\therefore Using Eq. (i),

$$T - 2 = 1$$

$$\text{i.e., } T = 3 \text{ N}$$

Option (d) is correct.

2. At point A

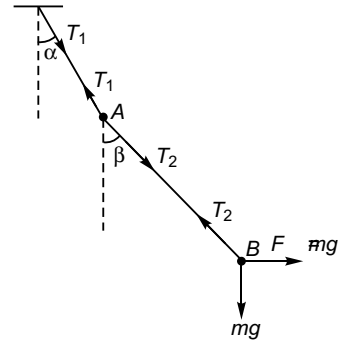

$$T_1 \cos \alpha = T_2 \cos \beta + mg \quad \dots(i)$$

$$\text{and } T_1 \sin \alpha = T_2 \sin \beta \quad \dots(ii)$$

At point B

$$T_2 \cos \beta = mg \quad \dots(iii)$$

$$T_2 \sin \beta = F - mg \quad \dots(iv)$$

Using Eq. (iii) in Eq. (i),

$$T_1 \cos \alpha = 2T_2 \cos \beta \quad \dots(v)$$

Dividing Eq. (ii) by Eq. (v),

$$2 \tan \alpha = \tan \beta \quad \dots(vi)$$

Option (a) is correct.

Squaring and adding Eqs. (iii) and (v),

$$T_1^2 = 4T_2^2 \cos^2 \beta + T_2^2 \sin^2 \beta \quad \dots(vii)$$

Dividing Eq. (iii) by Eq. (iv)

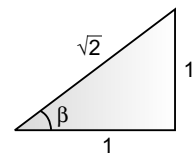

$$\tan \beta = 1$$

$$\therefore \cos \beta = \frac{1}{\sqrt{2}} = \sin \beta$$

Substituting the values of $\sin \beta$ and $\cos \beta$ in Eq. (vii)

$$\begin{aligned} T_1^2 &= 4T_2^2 \left(\frac{1}{2}\right) + T_2^2 \left(\frac{1}{2}\right) \\ &= \frac{5}{2} T_2^2 \end{aligned}$$

$$\Rightarrow \sqrt{2}T_1 = \sqrt{5}T_2$$

Option (c) is correct.

3. Displacement of block in 4 s

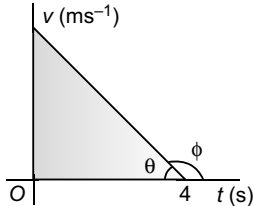

$$S = \text{Area under curve} \\ = 16 \text{ m.}$$

$\Delta K = \text{Workdone by frictional force}$

$$\frac{1}{2} \times 1 \times 4^2 = \mu \times 1 \times 10 \times 16$$

$$\Rightarrow \mu = 0.1$$

Option (a) is correct.

Option (b) is incorrect.

$$\begin{aligned} \text{Acceleration, } a &= \tan \phi \\ &= \tan (\pi - \theta) \\ &= -\tan \theta \\ &= -1 \text{ m/s}^2 \end{aligned}$$

If half rough retardation = 0.5 m/s^2

$$\therefore 16 = 4t + \frac{1}{2}(-0.5)t^2$$

$$\text{i.e., } t^2 - 16t + 64 = 0$$

$$\text{or } t = 8 \text{ s}$$

Option (d) is correct.

Option (c) is incorrect.

4. Let acceleration of wedge (A) = a

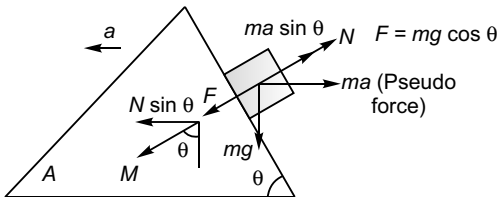

$$N + ma \sin \theta = mg \cos \theta$$

$$N = mg \cos \theta - ma \sin \theta$$

Acceleration of

$$a = \frac{N \sin \theta}{M}$$

$$\text{or } Ma = (mg \cos \theta - ma \sin \theta) \sin \theta$$

$$\text{or } a(M + m \sin^2 \theta) = mg \cos \theta \sin \theta$$

$$\begin{aligned} \text{i.e., } a &= \frac{mg \cos \theta \sin \theta}{M + m \sin^2 \theta} \\ &= \frac{0.6 \times g \times \cos 45^\circ \sin 45^\circ}{1.7 + (0.6 \times \sin^2 45^\circ)} \\ &= \frac{3g}{17 + 3} \\ &= \frac{3g}{20} \end{aligned}$$

Let $a_B = \text{Acceleration of block } B$

Net force on B (along inclined plane)

$$ma_B = ma \cos \theta + mg \sin \theta$$

$$\Rightarrow a_B = a \cos \theta + g \sin \theta$$

Thus, $(a_B)_V = (a \cos \theta + g \sin \theta) \cos \theta$

$$= a \cos^2 \theta + g \sin \theta \cos \theta$$

$$= (a + g) \frac{1}{2}$$

$$= \left(\frac{3g}{20} + g \right) \frac{1}{2}$$

$$= \frac{23g}{40}$$

$$(a_B)_H = (a \cos \theta + g \sin \theta) \sin \theta - a$$

$$= \frac{23g}{40} - \frac{3g}{20}$$

$$= \frac{17g}{40}$$

5. $f_1 (\text{max.}) = \mu_1 m_A g$

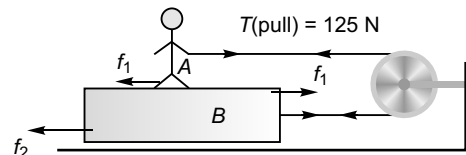

$$= 0.3 \times 60 \times 10$$

$$= 180 \text{ N}$$

$$F_{\text{net on } B} = f_1 (\text{max.}) + T$$

$$= 180 + 125$$

$$= 305 \text{ N}$$

A will remain stationary as

$$T < f_1 (\text{max.})$$

$$\therefore f_1 = 125 \text{ N}$$

Force of friction acting between A and B = 125 N

\therefore Options (c) and (d) are incorrect.

$$\begin{aligned}
 f_2 (\text{max}) &= \mu_2 (m_A + m_B) g \\
 &= 0.2(60 + 40) 10 \\
 &= 200 \text{ N}
 \end{aligned}$$

$$f_1 + T = 125 + 125 = 250 \text{ N}$$

As, $f_1 + T > f_2$ (max. block B /along the A as A is stationary) will move towards right with acceleration.

Option (a) is correct.

$$\begin{aligned}
 a_B &= \frac{(f_1 + T) - f_2 (\text{max.})}{m_B + m_A} \\
 &= \frac{250 - 200}{40 + 60} \\
 &= 0.5 \text{ m/s}^2
 \end{aligned}$$

Option (b) is correct.

6. (See solution to Question no. 4).

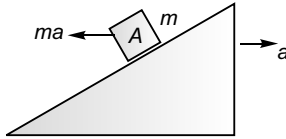

$$N = mg \cos \theta - ma \sin \theta$$

Option (c) is correct and option (d) is incorrect.

As angle between the directions of a and $g \sin \theta$ will be less than 90° , acceleration of block A will be more than $g \sin \theta$.

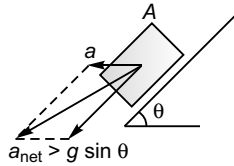

Option (a) is correct and option (b) is incorrect.

7. Maximum value of friction.

$$\begin{aligned}
 f_1 &= \text{between A and B} \\
 &= 0.25 \times 3 \times 10 = 7.5 \text{ N}
 \end{aligned}$$

$$\begin{aligned}
 f_2 &= \text{between B and C} \\
 &= 0.25 \times 7 \times 10 = 17.5 \text{ N}
 \end{aligned}$$

$$\begin{aligned}
 f_3 &= \text{between C and ground} \\
 &= 0.25 \times 15 \times 10 = 37.5 \text{ N}
 \end{aligned}$$

(a)

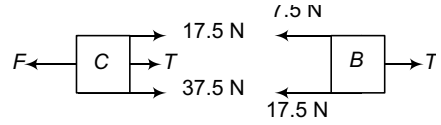

$$T = 17.5 + 7.5 = 25 \text{ N}$$

$$F = T + 37.5 + 17.5 = 80 \text{ N}$$

$$(c) T - 7.5 - 17.5 = 4a \quad \dots(i)$$

$$F - T - 37.5 - 17.5 = 8a \quad \dots(ii)$$

$$F = 200 \text{ N} \quad \dots(iii)$$

Solving these equations we get,

$$a = 10 \text{ m/s}^2$$

8. Maximum value of friction available to block is less than the maximum value of friction available to man.

$$9. N \sin \theta = ma = 1 \times 5 = 5 \quad \dots(i)$$

$$N \cos \theta = mg = 1 \times 10 = 10 \quad \dots(ii)$$

Solving these two equations we get, $\tan \theta = \frac{1}{2}$ and $N = 5\sqrt{5} \text{ N}$.

10. Let f_1 = friction between 2 kg and 4 kg

f_2 = friction between 4 kg and ground

$$(f_{s1})_{\text{max}} = 0.4 \times 2 \times 10 = 8 \text{ N}$$

$$(f_{k1}) = 0.2 \times 2 \times 10 = 4 \text{ N}$$

$$(f_{s2})_{\text{max}} = 0.6 \times 6 \times 10 = 36 \text{ N}$$

$$F_{k2} = 0.4 \times 6 \times 10 = 24 \text{ N}$$

$$(b) \text{ At } t = 1 \text{ s, } F = 2 \text{ N} < (f_{s2})_{\text{max}}$$

\therefore Both the blocks are at rest.

$$\therefore f_1 = 0$$

$$(c) \text{ At } t = 4 \text{ s, } F = 8 \text{ N} < (f_{s2})_{\text{max}}$$

\therefore Both the blocks are at rest.

$$f_2 = F = 8 \text{ N,}$$

$$11. a = 0, T_1 = 10 \text{ N,}$$

$$T_2 = 20 + T_1 = 30 \text{ N,}$$

$$T_3 = 20 \text{ N.}$$

$$12. f_{\text{max}} = 0.3 \times 2 \times 10 = 6 \text{ N}$$

$$(a) \text{ At } t = 2 \text{ s, } F = 2 \text{ N}$$

$$\therefore f = 2 \text{ N}$$

$$(b) \text{ At } t = 8 \text{ s, } F = 8 \text{ N} > 6 \text{ N}$$

$$\therefore f = 6 \text{ N}$$

(c) At $t = 10$ s, $F = 10$ N and $f = 6$ N

$$\therefore a = \frac{10 - 6}{2} = 2 \text{ m/s}^2$$

(d) Block will start at 6 s. After that, net impulse

$$= \frac{1}{2} \times 4 \times (6 + 10) + 2 \times 10 - 6 \times 6$$

$$= 16 \text{ N-s} = mv$$

$$\therefore v = \frac{16}{2} = 8 \text{ m/s.}$$

13. $f_{\text{max}} = 0.4 \times 2 \times 10 = 8$ N

(b) At $t = 3$ s, $F = 6$ N

\therefore Common acceleration

$$a = \frac{6}{6} = 1 \text{ m/s}^2$$

\therefore Pseudo force on 2 kg

$$= 2 \times 1 = 2 \text{ N} \quad (\text{backward})$$

14. $N = Mg - F \sin \theta$

$$F \cos \theta = \mu N = \mu(Mg - F \sin \theta)$$

$$\therefore F = \frac{\mu Mg}{\cos \theta + \mu \sin \theta}$$

For F to be minimum,

$$\frac{dF}{d\theta} = 0$$

Match the Columns

1. Acceleration after $t = 4$ s

At $t = 4$ s, $F = 8$ N

$$\therefore F_{\text{max}} = 8$$

$$\text{i.e., } \mu_s mg = 8$$

$$\Rightarrow \mu_s = \frac{8}{mg} = \frac{8}{2 \times 10} = 0.4$$

\therefore (a) \rightarrow (r)

At $t = 4$ s, $a = 1 \text{ ms}^{-2}$

$t = 4$ s, $F = 8$ N

$$F - \mu_k N = ma$$

$$\text{i.e., } \mu_k = \frac{F - ma}{N} = \frac{F - ma}{mg}$$

$$= \frac{8 - (2 \times 1)}{2 \times 10} = 0.3$$

(b) = (q)

At $t = 0.1$ s, $F = 0.2$ N

\therefore Force of friction (at $t = 0.1$ s) = 0.2 N

\therefore (c) \rightarrow (p)

At $t = 8$ s, $F = 16$ N

$$\therefore a = \frac{F - \mu_k mg}{m}$$

$$= \frac{16 - (0.3 \times 2 \times 10)}{2} = 5$$

$$\text{i.e., } \frac{a}{10} = 0.5$$

\therefore (d) \rightarrow (s).

2. At $\theta = 0^\circ$, dragging force = 0

\therefore Force of force = 0

\therefore (a) \rightarrow (s)

At $\theta = 90^\circ$

Normal force on block by plane will be zero.

\therefore Force of friction = 0

\therefore (b) \rightarrow (s)

At $\theta = 30^\circ$

$$\text{Angle of repose} = \tan^{-1} \mu$$

$$= \tan^{-1}(1) = 45^\circ$$

As $\theta <$ angle of repose, the block will not slip and thus,

$$\text{force of friction} = mg \sin \theta$$

$$= 2 \times 10 \times \sin 30^\circ = 10 \text{ N}$$

\therefore (c) \rightarrow (p)

At $\theta = 60^\circ$

As $\theta >$ angle of repose

Block will accelerate and thus force of friction = μN

$$= 1 \times 2 \times 10 \times \cos 60^\circ$$

$$= 10 \text{ N}$$

\therefore (d) \rightarrow (p).

3. All contact forces (e.g., force of friction and normal reaction) are electromagnetic in nature.

\therefore (a) \rightarrow (q), (r)

(b) \rightarrow (q), (r).

Nuclear force is the force between nucleons (neutrons and protons). Between two protons field force also acts.

4. (a) $N_R - 10 = 2(+5)$

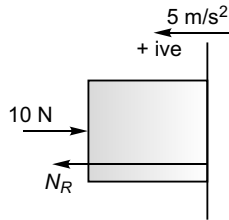

$\Rightarrow N_R = 20 \text{ N}$

\therefore (a) \rightarrow (f)

(b) $mg (= 20 \text{ N}) > F (= 15 \text{ N})$

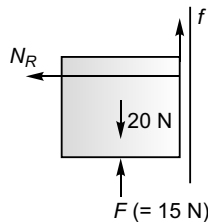

Block would be slipping in the downward direction.

Force of friction will be in the upward direction.

Frictional force = $20 - 15 = 5 \text{ N}$

\therefore (b) \rightarrow (p)

(c) If $F = 0$, the block will slip downwards due to $mg (= 20 \text{ N})$

Limiting friction = $\mu_s N_R = 0.4 \times 20 = 8 \text{ N}$

Minimum value of F for stopping the block moving down = $20 - 8 = 12 \text{ N}$

\therefore (c) \rightarrow (s).

(d) $F = mg + 8 = (2 \times 10) + 8 = 28 \text{ N}$

\therefore (d) \rightarrow (s)

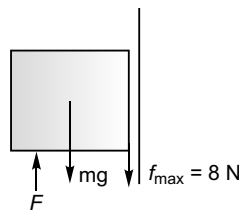

5. (a) As block A is stationary, $f = 10 \text{ N}$

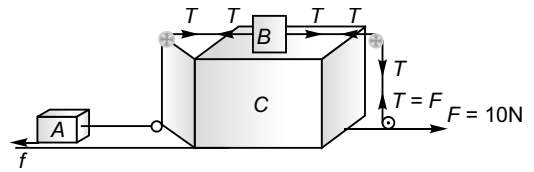

\therefore (a) \rightarrow (p)

(b) As block C is stationary force of friction between C and ground will be zero.

\therefore (b) \rightarrow (s)

(c) Normal force (N_C) on C from ground

$$\begin{aligned} N_C &= N_B + m_C g \\ &= m_B g + m_C g \\ &= (m_B + m_C) g \\ &= (1 + 1) 10 = 20 \text{ N} \end{aligned}$$

\therefore (c) \rightarrow (q).

(d) As block A is stationary

$$\begin{aligned} T &= F \text{ (as shown in figure)} \\ &= 10 \text{ N} \end{aligned}$$

\therefore (a) \rightarrow (p).

6. If friction force (f) is less than the applied force (F).



Net force on body = $F - f$

The body will be in motion and thus the friction will be kinetic.

\therefore (a) \rightarrow (q)

(b) If friction force (f) is equal to the force applied, the body will be at rest. If the body is at the point of slipping the force of friction will be limiting too. Emphasis is being given to the word "may be" as when a body is moving and the external force is made just equal to the frictional force, the body would still be moving with friction force at its limiting (kinetic) value.

\therefore (b) \rightarrow (p), (r)

(c) If object is moving the friction would be kinetic as explained in (a).

\therefore (c) \rightarrow (q).

(d) If the object is at rest, then friction may be static and limiting as explained in (b).

\therefore (d) \rightarrow (p), (r)

7. (a) Normal force between A and B = $m_A g$
 $f_1(\text{max.}) = \mu_1 m_A g$ (towards left)



$$= 0.2 \times 2 \times 10$$

$$= 4 \text{ N}$$

Normal force between B and C

$$= (m_A + m_B) g$$

$$f_2(\text{max}) = \mu_2 (m_A + m_B) g$$

$$= 0.1(2 + 3) \times 10$$

$$= 5 \text{ N}$$

Total friction force on 3 kg block

$$= f_1(\text{max}) + f_2(\text{max}) = 4 + 5$$

$$= 9 \text{ N towards left}$$

\therefore (a) \rightarrow (q), (s)

(b) Friction force on 5 kg block

$$= f_2(R) = f_2(\text{max})$$

$$= 5 \text{ N, towards right}$$

\therefore (b) \rightarrow (p), (s)

(c) Friction force on 2 kg block due to 3 kg block = $f_1(R)$

$$= f_1(\text{max})$$

$$= 4 \text{ N, towards right}$$

\therefore (c) \rightarrow (p), (s)

- (d) Friction force on 3 kg block due to 5 kg block = $f_2(\text{max})$
 $= 5 \text{ N, towards left.}$

\therefore (d) \rightarrow (q), (s).

8. (a) and (b)

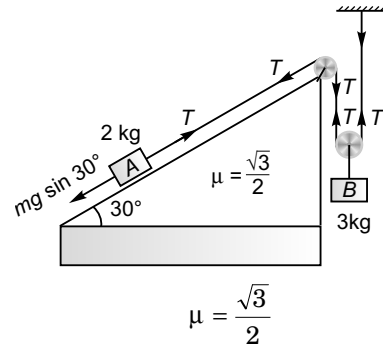

$$\mu = \frac{\sqrt{3}}{2}$$

\therefore Angle of repose = $\tan^{-1} \frac{\sqrt{3}}{2} = 40.89^\circ$

Now as, angle of incline (30°) < angle repose ($= 40.89^\circ$)

The block A and so also B will remain stationary.

\therefore (a) \rightarrow (r),

(b) \rightarrow (r)

(c) Tension (T) in the string connecting

$$2 \text{ kg mass} = mg \sin 30^\circ$$

$$= 2 \times 10 \times \frac{1}{2}$$

$$= 10 \text{ N}$$

\therefore (c) \rightarrow (s)

(d) Friction force on 2 kg mass = zero.

\therefore (d) \rightarrow (r).

6

Work, Energy and Power

Introductory Exercise 6.1

1. Work done by $\vec{F} = \vec{F} \cdot \vec{x}$

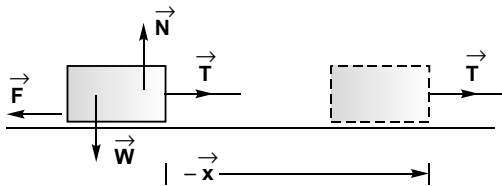

$$|\vec{F}| = F, |\vec{N}| = N, |\vec{W}| = W$$

$$|\vec{T}| = T \text{ and } |\vec{x}| = x$$

$$= |\vec{F}| |\vec{x}| \cos \pi$$

$$= -Fx$$

Work done by $\vec{N} = \vec{N} \cdot \vec{x}$

$$= |\vec{N}| |\vec{x}| \cos \frac{\pi}{2}$$

$$= 0$$

Work done by $\vec{W} = \vec{W} \cdot \vec{x}$

$$= |\vec{W}| |\vec{x}| \cos \frac{\pi}{2}$$

$$= 0$$

Work done by $\vec{T} = \vec{T} \cdot \vec{x}$

$$= |\vec{T}| |\vec{x}| \cos 0$$

$$= Tx$$

2. Work done by $\vec{F} = \vec{F} \cdot \vec{l}$

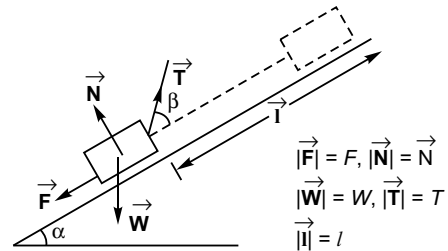

$$|\vec{F}| = F, |\vec{N}| = N$$

$$|\vec{W}| = W, |\vec{T}| = T$$

$$|\vec{l}| = l$$

$$= |\vec{F}| \cdot |\vec{l}| \cos \pi$$

$$= -Fl$$

Work done by $\vec{N} = \vec{N} \cdot \vec{l}$

$$= |\vec{N}| \cdot |\vec{l}| \cos \frac{\pi}{2} = 0$$

Work done by $\vec{W} = \vec{W} \cdot \vec{l}$

$$= |\vec{W}| |\vec{l}| \cos \left(\frac{\pi}{2} + \alpha \right)$$

$$= -Wl \sin \alpha$$

Work done by $\vec{T} = \vec{T} \cdot \vec{l}$

$$= |\vec{T}| |\vec{l}| \cos \beta$$

$$= Tl \cos \beta$$

3. $\vec{W} - \vec{T} = m \frac{\vec{g}}{4}$

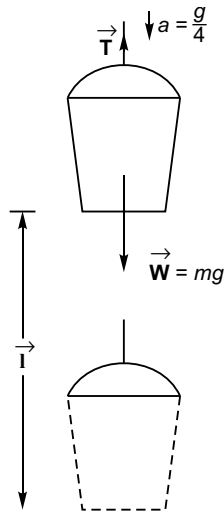

$|\vec{g}| = g$ and $|\vec{l}| = l$

$\therefore |\vec{T}| = m \vec{g} - \frac{m \vec{g}}{4}$
 $= \frac{3}{4} m \vec{g}$

Work done by string = $\vec{T} \cdot \vec{l}$
 $= |\vec{T}| |\vec{l}| \cos \pi$
 $= \left| \frac{3}{4} m \vec{g} \right| |\vec{l}| \cos \pi$
 $= -\frac{3}{4} mgl$

4. $\mu N = F \cos 45^\circ$... (i)

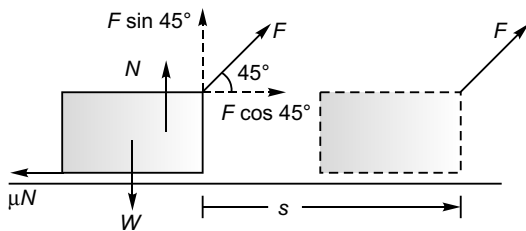

$N = |\vec{N}|, W = |\vec{W}|$

$s = |\vec{s}|, F = |\vec{F}|, g = |\vec{g}|$

$N + F \sin 45^\circ = W$... (ii)

Substituting value of N from Eq. (ii) in Eq. (i).

$\mu (W - F \sin 45^\circ) = F \cos 45^\circ$
 or $\frac{1}{4} (W - F \frac{1}{\sqrt{2}}) = F \frac{1}{\sqrt{2}}$
 or $W - \frac{F}{\sqrt{2}} = 4 \frac{F}{\sqrt{2}}$
 or $\frac{5F}{\sqrt{2}} = W$
 or $F = \frac{\sqrt{2}}{5} W = \frac{\sqrt{2}}{5} mg$

Work done by force $F = \vec{F} \cdot \vec{s}$

$= |\vec{F}| |\vec{s}| \cos 45^\circ = F s \frac{1}{\sqrt{2}}$
 $= \left(\frac{\sqrt{2}}{5} mg \right) s \frac{1}{\sqrt{2}} = \frac{mgs}{5}$
 $= \frac{1.8 \times 10 \times 2}{5}$
 $= 7.2 \text{ J}$

Work done by friction = $\mu \vec{N} \cdot \vec{s}$

$= \mu |\vec{N}| |\vec{s}| \cos \pi$
 $= -\mu Ns$
 $= -F \cos 45^\circ s$
 $= -7.2 \text{ J}$

Work done by gravity = $\vec{g} \cdot \vec{s}$

$= |\vec{g}| \cdot |\vec{s}| \cos \frac{\pi}{2}$
 $= 0$

5. $F = mg \sin 45^\circ$

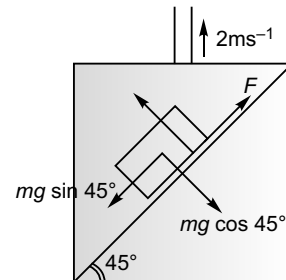

$= 1 \times 10 \times \frac{1}{\sqrt{2}}$

$= 5\sqrt{2} \text{ N}$

Displacement of lift in 1s = 2m

Work done by force of friction (F) = $\vec{F} \cdot \vec{s}$

$$= |\vec{F}| |\vec{s}| \cos 45^\circ$$

$$= F s \cos 45^\circ = 5\sqrt{2} \cdot 2 \cdot \frac{1}{\sqrt{2}} = 10 \text{ Nm}$$

6. Total work-done by spring on both masses

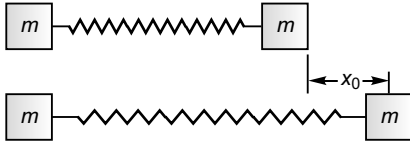

= PE of the spring when stretched by $2x_0$

$$= \frac{1}{2} k (2x_0)^2$$

$$= 2kx_0^2$$

\therefore Work done by spring on each mass

$$= \frac{2kx_0^2}{2} = kx_0^2$$

7. Work done = Area under the curve

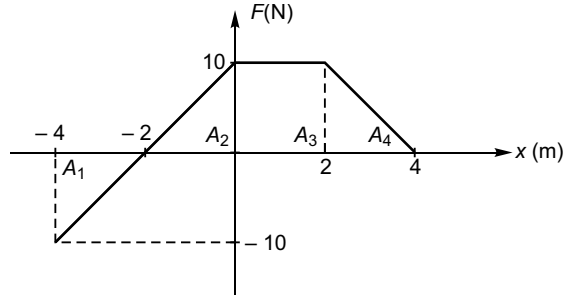

$$= A_1 + A_2 + A_3 + A_4$$

$$= \left[\frac{-2 \times -10}{2} \right] + \left[\frac{-2 \times 10}{2} \right] + [10 \times 2]$$

$$+ \left[\frac{2 \times 10}{2} \right]$$

$$= 30 \text{ Nm}$$

Introductory Exercise 6.2

1. $a = \frac{-20 \text{ ms}^{-1}}{2 \text{ s}} = -10 \text{ ms}^{-2}$

$\therefore F = ma = 2 \text{ kg} \times -10 \text{ ms}^{-2} = -20 \text{ N}$

$s = \text{Area under curve}$

$$= \frac{1}{2} \times 25 \times 20 \text{ ms}^{-1}$$

$$= 20 \text{ m}$$

\therefore Work done = $F s = (-20 \text{ N})(20 \text{ m})$

$$= -400 \text{ Nm}$$

2. According to A (inertial frame)

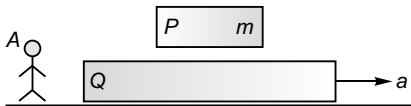

Acceleration of $P = a$

\therefore Force on $P = ma$

Work done over s displacement = mas

Now, $v^2 = u^2 + 2as$

$$= 2as \quad (\because u = 0)$$

\therefore Gain in KE = $\frac{1}{2}mv^2 = \frac{1}{2}m \cdot 2as = mas$

$\therefore \Delta K = W$ (Work-Energy theorem)

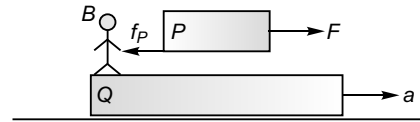

According to B (non-inertial frame)
work done

= Work done by F + Work done by f_p
(pseudo force)

$$= (mas) + (-mas) = 0$$

As P is at rest, $\Delta K = 0$

$\therefore \Delta K = W$ (Work-Energy theorem)

Note In inertial frames one has to also consider work-done due to pseudo forces, while applying Work-energy theorem.

3. $v = \alpha \sqrt{x}$

$$\therefore a = \frac{dv}{dt} = \alpha \frac{1}{2\sqrt{x}} \frac{dx}{dt}$$

$$= \alpha \frac{1}{2\sqrt{x}} \alpha \sqrt{x} = \frac{\alpha^2}{2}$$

$$F = ma = m \frac{\alpha^2}{2}$$

$\therefore W = \frac{m\alpha^2}{2} b$

4. $\Delta K = \text{Work done by } F$

+ Work done by gravity

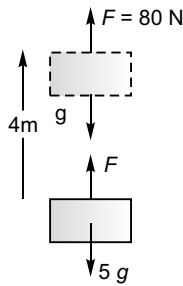

$$= 80 \cdot 4 \cdot \cos 0 + 5g \cdot 4 \cdot \cos \pi$$

$$= 320 + (-200)$$

or $K_f - K_i = 120 \text{ J}$

or $K_f = 120 \text{ J}$ (as $K_i = 0$)

5. Change in KE = Work done

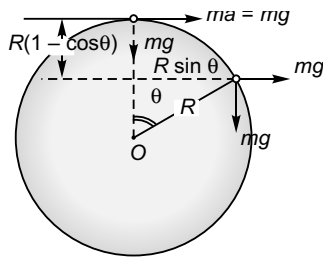

$$\frac{1}{2}mv^2 = mgR(1 - \cos \theta) + mgR \sin \theta$$

$$\Rightarrow v = \sqrt{2gR(1 - \cos \theta + \sin \theta)}$$

6. $\Delta K = W$

or $0 - \frac{1}{2}mv_0^2 = \int_0^x -Ax dx$

or $-\frac{1}{2}mv_0^2 = -A \frac{x^2}{2}$

$$\Rightarrow x = v_0 \sqrt{\frac{m}{A}}$$

7. (a) If $T = mg$, the block will not get accelerated to gain KE. The value of T must be greater than Mg .

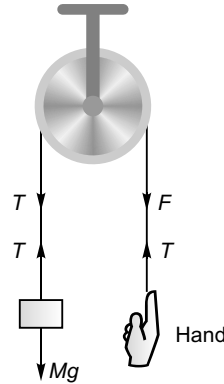

\therefore **Ans.** False

(b) As some negative work will be done by Mg , the work done by T will be more than 40 J.

\therefore **Ans.** False

(c) Pulling force F will always be equal to T , as T is there only because of pulling.

\therefore **Ans.** True

(d) Work done by gravity will be negative
Ans. False

Introductory Exercise 6.3

1. In Fig. 1

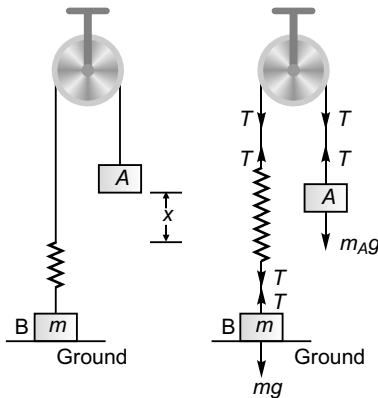

Fig. 1

Fig. 2

Spring is having its natural length.

In Fig. 2 A is released. A goes down by x . Spring get extended by x . Decrease in PE of A is stored in spring as its PE.

$$\therefore mAgx = \frac{1}{2}kx^2$$

Now, for the block B to just leave contact with ground

$$kx = mg$$

i.e., $2m_A g = mg$

$$\Rightarrow m_A = \frac{m}{2}$$

112 | Mechanics-1

2. Decrease in PE = $mg \frac{l}{2}$

$\therefore \frac{1}{2}mv^2 = mg \frac{l}{2}$

i.e., $v = \sqrt{gl}$

3. OA = 50 cm

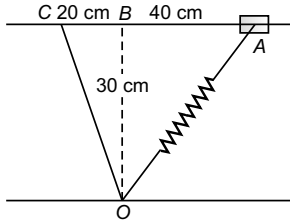

\therefore Extension in spring (when collar is at A)
= 50 cm – 10 cm = 0.4 m

Extension in spring (collar is at B)
= 30 cm – 10 cm
= 20 cm = 0.2 m

KE of collar at B

= PE of spring – PE of spring
(collar at A) (collar at B)
= $\frac{1}{2} \times K \times [(0.4)^2 - (0.2)^2]$

or $\frac{1}{m}mv_B^2 = \frac{1}{2} \times 500 \times 12$

or $v_B = \sqrt{\frac{500 \times 0.12}{10}} = 2.45 \text{ s}^{-1}$

Extension in spring (collar arrives at C)
= $[\sqrt{(30)^2 + (20)^2} - 10] \text{ cm} = 0.26 \text{ m}$

KE of collar at C

= PE of spring – PE of spring

(Collar at A) (Collar at C)
= $\frac{1}{2} \times 500 \times [(0.4)^2 - (0.26)^2]$

or $\frac{1}{2}mv_C^2 = \frac{1}{2} \times 500 \times 0.0924$

or $v_C = \frac{500}{100} \times 0.0924 = 2.15 \text{ m s}^{-1}$

4. Work done by man = $\frac{m}{2}gh + Mgh$
= $\left(\frac{m}{2} + M\right)gh$

5. When block of man M goes down by x , the spring gets extended by x . Decrease in PE of man M is stored in spring as its PE.

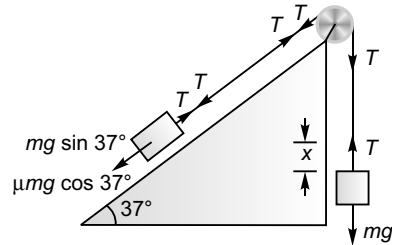
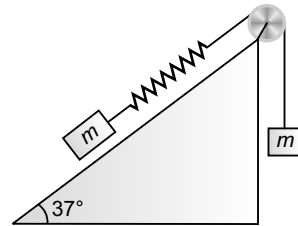

$\therefore Mg x = \frac{1}{2}kx^2$

or $kx = 2Mg$

For the block of man m to just slide

$kx = mg \sin 37^\circ + \mu mg \cos 37^\circ$

or $2Mg = mg \frac{3}{5} + \frac{3}{4}mg \frac{4}{5}$

or $M = \frac{3}{5}m$

Introductory Exercise 6.4

1. Velocity at time $t = 2 \text{ s}$

$v = gt = 10 \times 2 = 20 \text{ ms}^{-1}$

Power = Force \times velocity

= $mgv = 1 \times 10 \times 20 = 200 \text{ W}$

2. Velocity at time = $a t = \frac{F}{m} \cdot t$

$\therefore v_{av} = \frac{Ft}{2m}$ (acceleration being constant)

$P_{av} = F \times v_{av} = \frac{F^2 t}{2m}$

Instantaneous power

= Force \times instantaneous velocity

$$= F \cdot \frac{Ft}{m} = \frac{F^2 t}{m}$$

3. Power = $\frac{\text{Energy}}{\text{Time}}$

$$P = \frac{\text{KE}}{t} \Rightarrow \text{KE} = P \cdot t$$

$$\therefore \frac{1}{2}mv^2 = Pt$$

or $v = \sqrt{\frac{2Pt}{m}}$

or $\frac{ds}{dt} = \sqrt{\frac{2P}{m}} \cdot t^{1/2}$

or $\int ds = \sqrt{\frac{2P}{m}} \int t^{1/2} dt$

or $s = \sqrt{\frac{2P}{m}} \frac{t^{3/2}}{3/2} + c$

At $t = 0, s = 0, \therefore c = 0$

Thus, $s = \sqrt{\frac{8P}{9m}} t^{3/2}$

4. $P = 2t$

$$\text{KE} = \int P dt = \int 2t dt = t^2 + c$$

As at $t = 0, \text{KE} = 0, c = 0$

$$\therefore \text{KE} = t^2$$

i.e., $\frac{1}{2}mv^2 = t^2$ or $v = \sqrt{\frac{2}{m}} t$

$$P_{\text{av}} = \frac{2.0 + 2t}{2} = t$$

5. $U = -20 + (x - 2)^2$

PE(= U) is minimum at $x = 2$.

\therefore Equilibrium position is at $x = 2$ m

$$\frac{dU}{dx} = 2(x - 2)$$

$$\frac{d^2U}{dx^2} = 2$$

\therefore Equilibrium is stable.

6. $F = x - 4$

For equilibrium, $F = 0$

i.e., $x - 4 = 0$

i.e., $x = 4$ m

As, $F = -\frac{dU}{dx}$

$$\frac{dU}{dx} = -(x - 4)$$

$$\therefore \frac{d^2U}{dx^2} = -1$$

Thus, equilibrium is unstable.

AIEEE Corner

Subjective Questions (Level I)

(a) Work done by a constant force

1. (a) Work done by a constant force

Work done by applied force = $F s \cos 0$

$$= 40 \times 2 = 80 \text{ Nm}$$

Work done by force of gravity = $mgs \cos \pi$

$$= 2 \times 10 \times 2 \times -1 = -40 \text{ Nm}$$

2. $\vec{r}_{21} = \vec{r}_2 - \vec{r}_1$

$$= (2\hat{i} + 3\hat{j} - 4\hat{k}) - (1\hat{i} + 4\hat{j} + 6\hat{k})$$

$$= \hat{i} - \hat{j} - 10\hat{k}$$

Work done = $\vec{F} \cdot \vec{r}_{21}$

$$= (6\hat{i} - 2\hat{j} + \hat{k}) \cdot (\hat{i} - \hat{j} - 10\hat{k})$$

$$= 6 + 2 - 10 = -2 \text{ Nm}$$

3. $m_1g - T = m_1a \quad \dots(i)$

$T - m_2g = m_2a \quad \dots(ii)$

Solving Eq. (i) and Eq. (ii),

$$a = \frac{m_1 - m_2}{m_1 + m_2} g$$

$$= \frac{4 - 1}{4 + 1} g$$

$$\left(\because m_1 = 4 \text{ kg} \right. \\ \left. \text{and } m_2 = 1 \text{ kg} \right)$$

$$= \frac{3}{5} g$$

$$s = ut + \frac{1}{2}at^2$$

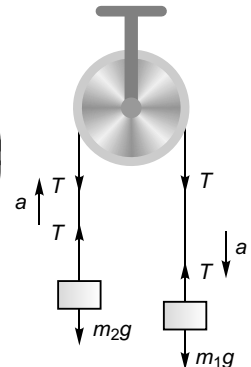

$$= \frac{1}{2} \left(\frac{3}{5} g \right) 2^2$$

$$= 12 \text{ m}$$

Work done by gravity on 4 kg block

$$= 4g \times 12 \cos 0$$

$$= 480 \text{ Nm}$$

Solving Eq. (i) and Eq. (ii),

$$T = \frac{2m_1m_2}{m_1 + m_2} g$$

$$= 2 \times \frac{4}{5} g$$

$$= 16 \text{ N}$$

Work done by string on 1 kg block

$$= 16 \times 12 \cos 0$$

$$= 192 \text{ Nm}$$

4. Work done by applied force = $F s \cos 45^\circ$

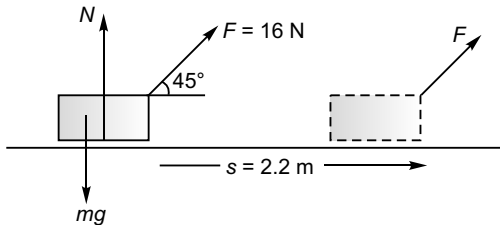

$$= 16 \times 2.2 \times \frac{1}{\sqrt{2}}$$

$$= 24.9 \text{ Nm}$$

Work done by normal force

$$= N s \cos 90^\circ = 0$$

Work done by force of gravity

$$= mgs \cos 90^\circ = 0$$

Total work done on the block

$$= 24.9 + 0 + 0$$

$$= 24.9 \text{ Nm}$$

5. Work done by gravity = $mgs \sin \theta$

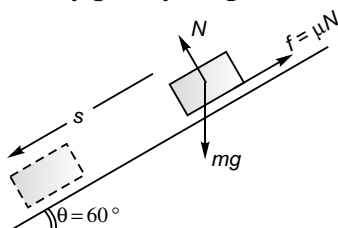

$$= 2 \times 10 \times 2 \sin 60^\circ$$

$$= 20\sqrt{3} \text{ Nm}$$

$$= 34.6 \text{ Nm}$$

Work done by force of friction

$$= f s \cos \pi$$

$$= \mu N s \cos \pi$$

$$= -\mu (mg \cos \theta) s$$

$$= -\frac{1}{2} (2 \times 10 \times \cos 60^\circ) \times 2$$

$$= -10 \text{ Nm}$$

(b) Work done by a variable force.

6. $W = \int F dx$

$$= \int_{x=2}^{x=-4} -2x dx$$

$$= - \left[\frac{2x^2}{2} \right]_{x=2}^{x=-4}$$

$$= - [(-4)^2 - (2)^2]$$

$$= -12 \text{ Nm}$$

7. $W = \int F dx$

$$= \int_{x=4}^{x=2} \frac{4}{x^2} dx$$

$$= \int_{x=4}^{x=2} 4x^{-2} dx$$

$$= \left[\frac{4x^{-2+1}}{-2+1} \right]_{x=4}^{x=2}$$

$$= -4 \left[\frac{1}{x} \right]_{x=4}^{x=2}$$

$$= -4 \left[\frac{1}{2} - \frac{1}{4} \right] = -1 \text{ Nm}$$

(c) Work done by area under $F-x$ graph

8. (a) $W = 3 \times (5 - 10) = -15 \text{ Nm}$

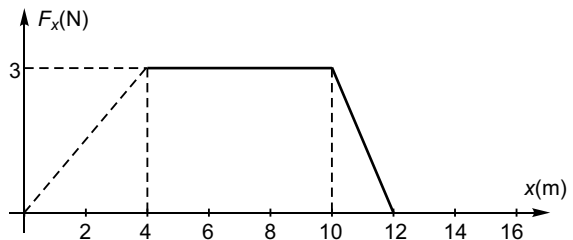

(b) $W = 3 \times (10 - 5) = +15 \text{ Nm}$

$$(c) W = \frac{3 \times (12 - 10)}{2} = 3 \text{ Nm}$$

$$(d) W = \frac{(10 - 4) + (12 - 0)}{2} \times 3$$

$$= +27 \text{ Nm}$$

$$9. (a) W = \frac{(3 - 2) + (3 - 0)}{2} \times 2$$

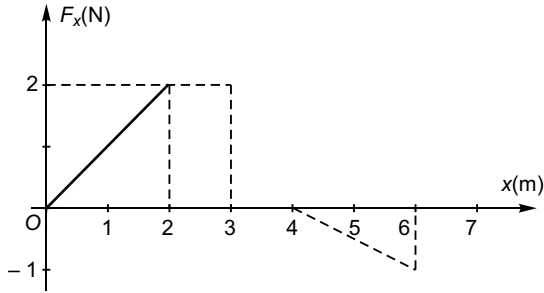

$$= 4 \text{ Nm}$$

$$(b) W = 0 \text{ Nm}$$

$$(c) W = \frac{1}{2} (6 - 4) (-1 - 0) = -1 \text{ Nm}$$

$$(d) W = 4 \text{ Nm} + 0 \text{ Nm} + (-1) \text{ Nm}$$

$$= 3 \text{ Nm.}$$

Conservative force field and Potential Energy.

$$10. F = - \frac{d}{dr} U$$

$$= - \frac{d}{dr} Ar^{-1}$$

$$= (-)(-A)r^{-1-1} = \frac{A}{r^2}$$

$$11. U = (x - 4)^2 - 16$$

$$\therefore \text{PE (at } x = 6.0 \text{ m)}$$

$$= (6 - 4)^2 - 16 = -12 \text{ J}$$

$$\text{KE (at } x = 6.0 \text{ m)} = 8 \text{ J}$$

$$(a) \therefore \text{Total mechanical energy}$$

$$= (-12) + (8) = -4 \text{ J}$$

(b) KE will be maximum where, PE, is minimum.

For U to be minimum,

$$\frac{dU}{dx} = 0$$

$$\text{i.e., } \frac{d}{dx} [(x - 4)^2 - 16] = 0$$

$$\text{or } 2(x - 4) = 0$$

$$\text{or } x = 4 \text{ m}$$

$$\therefore \text{minimum PE} = (4 - 4)^2 - 16$$

$$= -16 \text{ J}$$

Now, $(\text{KE})_{\text{max}} + (\text{PE})_{\text{min}} = \text{Total mechanical energy}$

$$\text{or } (\text{KE})_{\text{max}} + (-16) = -4$$

$$\text{or } (\text{KE})_{\text{max}} = 12 \text{ J}$$

$$(c) \text{PE}_{\text{max}} = \text{KE}_{\text{max}} = 12 \text{ J}$$

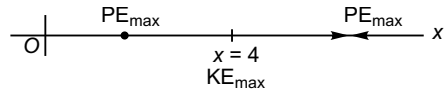

$$U = (x - 4)^2 - 16$$

$$\text{or } 12 = (x - 4)^2 - 16$$

$$\text{or } x^2 - 8x - 12 = 0$$

$$\Rightarrow x = 4 + 2\sqrt{3}$$

$$\text{and } x = 4 - 2\sqrt{3}$$

$$(d) U = (x - 4)^2 - 16$$

$$\frac{dU}{dx} = 2(x - 4)$$

$$\therefore F_x = - \frac{dU}{dx} = -2(x - 4)$$

$$\text{or } F_x = 8 - 2x$$

$$(e) F_x = 0$$

$$\text{i.e., } 8 - 2x = 0$$

$$\text{or } x = 4 \text{ m}$$

Kinetic energy and Work-energy theorem

$$12. K = \frac{p^2}{2m}$$

$$\therefore K' = \frac{\left(p + \frac{p}{2}\right)^2}{2m}$$

(K' is the KE when momentum p is increased by 50%)

$$\text{or } K' = \frac{9 p^2}{4 \cdot 2m}$$

$$\text{or } K' = \frac{9}{4} K$$

$$\text{or } K' - K = \frac{9}{4} K - K = \frac{5}{4} K$$

$$\therefore \frac{K' - K}{K} = \frac{5}{4}$$

$$= \frac{5}{4} \times 100\% = 125\%$$

116 | Mechanics-1

13. $p = (2mK)^{1/2}$
 $\therefore p' = [2m(K + 1\% \text{ of } K)]^{1/2}$
 (p' is the momentum when KE i.e., K is increased by 1%)

$$= [2mK(1 + 1\%)]^{1/2}$$

$$= (2mK)^{1/2} \left(1 + \frac{1}{100}\right)^{1/2}$$

i.e., $p' = p \left(1 + \frac{1}{100}\right)^{1/2}$

$$= p \left(1 + \frac{1}{2} \times \frac{1}{100}\right)$$

$$= p \left(1 + \frac{1}{2}\% \right)$$

$$p' = p + \frac{1}{2}\% \text{ of } p$$

\therefore Increase in momentum = 0.5 %.

14. $s = (2t^2 - 2t + 10) \text{ m}$
- $$\frac{ds}{dt} = 4t - 2$$
- $$\frac{d^2s}{dt^2} = 4 \text{ ms}^{-2}$$
- $$F = m \frac{d^2s}{dt^2}$$
- $$= 2 \times 4 = 8 \text{ N}$$

s (at $t = 0 \text{ s}$) = 10 m

s (at $t = 2 \text{ s}$) = $2 \cdot 2^2 - 2 \cdot 2 + 10 = 14 \text{ m}$

$\therefore \Delta s = 14 \text{ m} - 10 \text{ m} = 4 \text{ m}$

$$\text{Work} = F \Delta s$$

$$= 8 \text{ N} \times 4 \text{ m}$$

$$= 32 \text{ Nm}$$

15. $a = \frac{v^2}{2s} = \frac{(0.4)^2}{2 \times 2} = \frac{0.16}{4} = 0.04 \text{ m s}^{-2}$

$$\frac{mg - T}{m} = a$$

i.e., $T = m(g - a)$

$$= 30(10 - 0.04)$$

$$= 298.8 \text{ N}$$

Work done by chain = $T s \cos \pi$

$$= -(298.8 \times 2) \text{ Nm}$$

$$= -597.6 \text{ Nm}$$

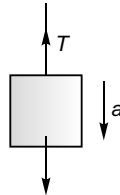

16. $a = \frac{10^2}{2 \times 20} = 2.5 \text{ ms}^{-2}$

Now, $mg - F = ma$

$$\therefore F = m(g - a)$$

$$= 5(10 - 2.5)$$

$$= 37.5 \text{ N}$$

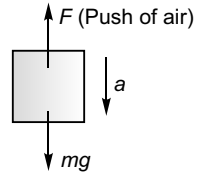

Work done by push of air

$$= F s \cos \pi$$

$$= -(37.5 \times 20)$$

$$= -750 \text{ Nm}$$

17. (a) $W = \int F dx$
- $$= \int_0^2 (2.5 - x^2) dx$$
- $$= \left[2.5x - \frac{x^3}{3} \right]_0^2$$
- $$= (2.5 \times 2) - \frac{2^3}{3}$$
- $$= 2.33 \text{ Nm}$$

$$\therefore \Delta K = 2.33 \text{ J} \quad (1 \text{ Nm} = 1 \text{ J})$$

i.e., KE (at $x = 2$) - KE (at $x = 0$) = 2.33 J

\therefore KE (at $x = 2$) = 2.33 J

(b) Position of maximum KE

$$F = 2.5 - x^2$$

$\therefore F$ decreases as x increases and F is zero when $x = \sqrt{2.5} \text{ m}$

Thus, work will be +ive from $x = 0$ to $x = \sqrt{2.5} \text{ m}$ and so KE will be maximum at $x = \sqrt{2.5} \text{ m}$.

KE (at $x = \sqrt{2.5} \text{ m}$)

$$= \int_0^{\sqrt{2.5}} (2.5 - x^2) dx$$

$$= \left[2.5x - \frac{x^3}{3} \right]_0^{\sqrt{2.5}}$$

$$= \left[2.5\sqrt{2.5} - \frac{2.5\sqrt{2.5}}{3} \right]$$

$$= \frac{2}{3} \times 2.5\sqrt{2.5}$$

$$= 2.635 \text{ J}$$

$$18. a = \frac{F - mg}{m}$$

$$\text{or } \frac{g}{10} = \frac{F}{m} - g$$

$$\text{or } F = \frac{11}{10} mg$$

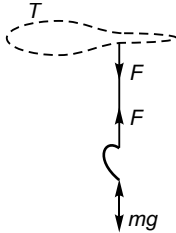

(a) \therefore Work done on astronaut by F

$$\begin{aligned} &= \frac{11mg}{10} \times 15 \\ &= \frac{11}{10} \times 72 \times 10 \times 15 \\ &= 11642.4 \text{ Nm} \end{aligned}$$

(b) Work done on astronaut by gravitational force

$$\begin{aligned} &= mgh \cos \pi \\ &= -72 \times 9.8 \times 15 = -10584 \text{ Nm} \end{aligned}$$

(c) Net work done on astronaut

$$= (11642.4) + (-10584) = 1058.4 \text{ Nm}$$

\therefore KE = 1058.4 J

$$(d) \frac{1}{2} mv^2 = 1058.4$$

$$\therefore v = \sqrt{\frac{1058.4 \times 2}{72}} = 5.42 \text{ ms}^{-1}$$

$$19. \quad T = m_2 a \quad \dots(i)$$

$$\text{and } m_1 g - T = m_1 a \quad \dots(ii)$$

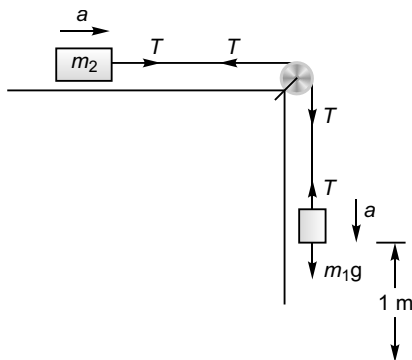

Adding Eq. (i) and Eq. (ii),

$$m_1 g = (m_1 + m_2) a$$

$$\therefore a = \frac{m_1}{m_1 + m_2} g$$

$$= \frac{1}{1 + 4} g \quad (\because m_1 = 1 \text{ kg and } m_2 = 4 \text{ kg})$$

$$= \frac{g}{5} = 2 \text{ ms}^{-2}$$

Now, $v^2 = u^2 + 2as$

i.e., $v^2 = 2as$ ($\because u = 0 \text{ ms}^{-1}$)

$$\begin{aligned} \text{or } v &= \sqrt{2as} \\ &= \sqrt{2 \times 2 \times 1} \\ &= 2 \text{ ms}^{-1} \end{aligned}$$

$$20. T - 50 = \frac{50}{10} a$$

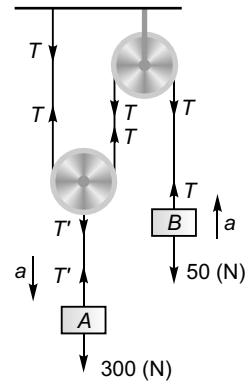

$$\text{or } T - 50 = 5a \quad \dots(i)$$

and

$$T' = 2T$$

$$\text{i.e., } T = \frac{T'}{2} \quad \dots(ii)$$

From Eq. (i) and Eq. (ii),

$$\frac{T'}{2} - 50 = 5a$$

$$\text{or } T' - 100 = 10a \quad \dots(iii)$$

$$\text{Also, } 300 - T' = \frac{300}{10} a$$

$$\text{i.e., } 300 - T' = 30a \quad \dots(iv)$$

Solving Eq. (iii) and Eq. (iv),

$$a = 5 \text{ ms}^{-2}$$

$$T' = 100 + 10a = 150 \text{ N}$$

21. $NR \cos(180^\circ - \alpha) + mgR = \frac{1}{2} mv_s^2$

$(mg \cos \alpha) R (-\cos \alpha) + mgR = \frac{1}{2} mv_s^2$

or $\frac{1}{2} mv_s^2 = mgR (1 - \cos^2 \alpha)$

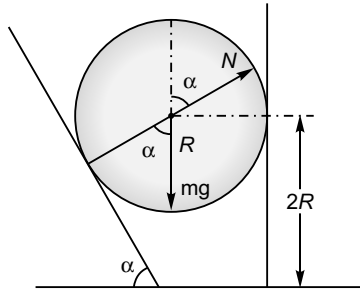

or $v_s^2 = 2gR \sin^2 \alpha$

or $v_s = \sqrt{2gR} \sin \alpha$

(v_s is the speed with which sphere hits ground)

$\frac{1}{2} mv_w^2 = mgR - \frac{1}{2} mv_s^2$

$= mgR - \frac{1}{2} m 2gR \sin^2 \alpha$

$= mgR (1 - \sin^2 \alpha) = mgR \cos^2 \alpha$

$\therefore v_w = \sqrt{2gR} \cos \alpha$

(v_w is the speed of wedge when the sphere hits ground)

22. For 45 kg mass to drop 12 mm, the increase in length of the spring will be 24 mm.

Now, decrease in PE of 45 kg mass

= Increase in KE of 45 kg mass + Increase in PE of spring

$45 \times 9.8 \times 12 \times 10^{-3} = \frac{1}{2} \times 45 \times v^2 + \frac{1}{2} \times 1050$

$\times [(75 + 24)^2 - 75^2] \times 10^{-6}$

i.e., $5.292 = 22.5v^2 + 2.192$

or $22.5v^2 = 3.0996$

or $v^2 = 0.13776$

or $v = 0.371 \text{ ms}^{-1}$

(b) With friction (when mechanical energy does not remain conserved)

23. Decrease in PE of 1 kg mass

= Work done against friction due to 4 kg mass + Increase in KE of 1 kg mass

$1 \times 10 \times 1 = \mu_k \times 4 \times 10 \times 2 + \frac{1}{2} \times 1 \times (0.3)^2$

or $10 = 80\mu_k + 0.045$

or $\mu_k = \frac{10 - 0.045}{80} = 0.124$

24. f = force of friction while disc is slipping over inclined surface = $\mu mg \cos 30^\circ$

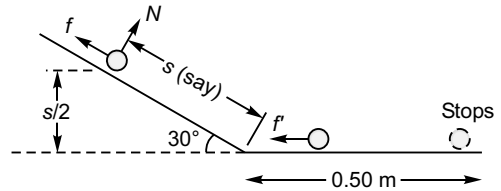

f' = force of friction while disc is slipping over plane surface = μmg

Now, decreases in PE of disc = Work done against frictional force

$mg \frac{s}{2} = fs + f'(0.5)$

or $mg \frac{s}{2} = (\mu mg \cos 30^\circ) s + \mu mg (0.5)$

or $mgs(0.5 - \mu \cos 30^\circ) = \mu mg (0.5)$

$\Rightarrow s = \frac{\mu \times 0.5}{0.5 - \mu \cos 30^\circ}$

$= \frac{0.15 \times 0.5}{0.5 - 0.15 \times \frac{\sqrt{3}}{2}} = 0.2027 \text{ m}$

Work performed by frictional forces over the whole distance

$= -mg \frac{s}{2} = -\frac{50}{1000} \times 10 \times \frac{0.2027}{2}$

$= -0.051 \text{ J}$

25. $m_A g \sin \theta - \mu m_A g \cos \theta - 2T = m_A a$

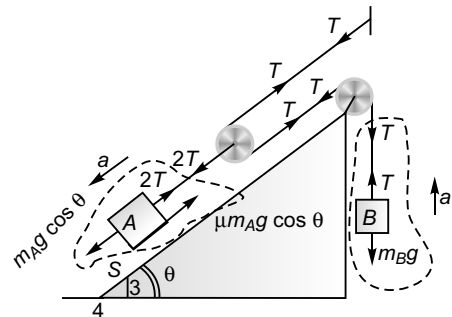

or $300 \times \frac{3}{5} - 0.2 \times 300 \times \frac{4}{5} - 2T = 30a$

$$\text{or } 180 - 48 - 2T = 30a$$

$$\text{or } 132 - 2T = 30a \quad \dots(i)$$

$$\text{Also, } T - m_B g = m_B a$$

$$\text{or } T - 50 = 5a$$

$$\text{or } 2T - 100 = 10a \quad \dots(ii)$$

Adding Eq. (i) and Eq. (ii),

$$32 = 40a$$

$$\text{or } a = 0.8 \text{ ms}^{-2}$$

Speed (v) of block A after it moves 1 m down the plane

$$v^2 = 2as$$

$$\text{or } v^2 = 2 \times 0.8 \times 1$$

$$\text{or } v = 1.12 \text{ ms}^{-1}$$

26. Work done by frictional force acting on block

$$= -\mu mgs$$

$$= -0.25 \times 35 \times 9.8 \times 7.8$$

$$= -66.88 \text{ J}$$

\therefore Increase in thermal energy of block-floor system

$$= 66.88 \text{ J}$$

As the block stopped after traversing 7.8 m on rough floor the maximum kinetic energy of the block would be 66.88 J (just before entering the rough surface).

Maximum PE of spring

$$= \text{Maximum KE of block}$$

$$\frac{1}{2} kx_{\max}^2 = 66.88$$

$$\therefore x_{\max} = \sqrt{\frac{2 \times 66.88}{640}} \text{ m}$$

Maximum compression in the spring

$$= 0.457 \text{ m}$$

27. Decrease in PE of mass $m_2 =$ Work done against friction by mass $m_1 +$ Increase KE of mass $m_1 +$ Increase in KE of mass m_2

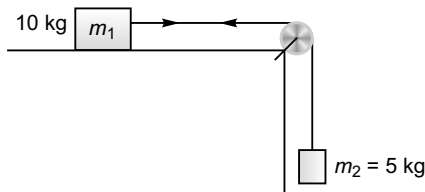

$$m_2 g \times 4 = \mu m_1 g \times 4 + \frac{1}{2} m_1 v^2 + \frac{1}{2} m_2 v_2^2$$

$$5 \times 10 \times 4 = 0.2 \times 10 \times 10 \times 4 + \frac{1}{2} (10 + 5) v^2$$

$$\text{Solving, } v = 4 \text{ ms}^{-1}$$

Three types of Equilibrium

28. (a) $F = -\frac{dU}{dr}$

Point	$\frac{dU}{dr}$	F
A	+ ive	- ive
B	+ ive	- ive
C	- ive	+ ive
D	- ive	+ ive
E	zero	zero

(b) $x = 2 \text{ m}$ point is of unstable equilibrium (U being +ive)

$x = 6 \text{ m}$ point is of stable equilibrium (U being lowest - ive)

29. $U = \frac{x^3}{3} - 4x + 6$

For U to be maximum (for unstable equilibrium) and minimum (for stable equilibrium)

$$\frac{dU}{dx} = 0$$

$$\text{i.e., } \frac{d}{dx} \left(\frac{x^3}{3} - 4x + 6 \right) = 0$$

$$\text{or } x^2 - 4 = 0$$

$$\text{or } x = \pm 2$$

$$\frac{d^2U}{dx^2} = \frac{d}{dx} (x^2 - 4) = 2x$$

At $x = +2 \text{ m}$,

$$\frac{d^2U}{dx^2} = 2 \times (+2) = +4$$

$\therefore U$ is minimum.

At $x = -2 \text{ m}$,

$$\frac{d^2U}{dx^2} = 2 \times (-2) = -4$$

$\therefore U$ is maximum.

$\therefore x = +2 \text{ m}$ point of stable equilibrium.

$x = -2 \text{ m}$ point of unstable equilibrium.

30. $F = -\frac{dU}{dx}$

i.e., $U = -\int F dx$
 $= -(\text{Area under } F - x \text{ graph})$

The corresponding U Vs x graph will be as shown in figure

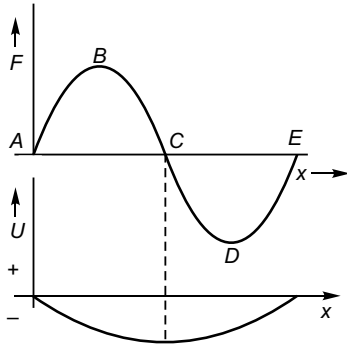

Thus, point C corresponds to stable equilibrium and points A and E correspond to unstable equilibrium.

31. $-q$ charge placed at origin is in equilibrium as is two equal and opposite forces act on it.

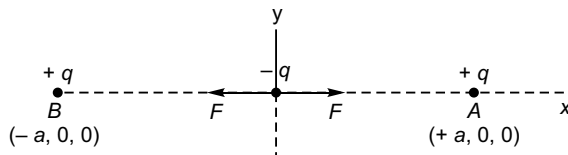

- (a) But, if we displace it slightly say towards +ive x side, the force on it due to charge to B will decrease while that due to A will increase.

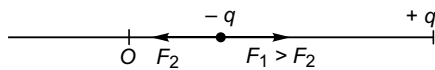

Due to net force on $-q$ towards right the charge $-q$ will never come back to original O, its origin position.

Thus, the equilibrium of the charge $-q$ is **unstable** if it is slightly displaced along x -axis.

- (b) If charge $-q$ is displaced slightly along Y axis, the net force on it will be along origin O and the particle will return to its original position. And as such the equilibrium of the $-q$ is stable.

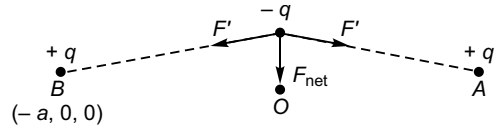

32. (a) Velocity at $t = 0$ s is 0 ms^{-1}
 Velocity at $t = 2$ s is 8 ms^{-1} (using $v = 0 + at$)
 $\therefore v_{av} = 4 \text{ m s}^{-1}$ (as acceleration is constant)

$$P_{av} = F \times v_{av}$$

$$= ma v_{av}$$

$$= 1 \times 4 \times 4 = 16 \text{ W}$$

- (b) Velocity at $t = 4$ s is 16 ms^{-1} (using $v = u + at$)
 \therefore Instantaneous power of the net force at $t = 4$ s will be

$$P = mav$$

$$= 1 \times 4 \times 16$$

$$= 64 \text{ W}$$

33. Power = $F_{min} v_{max}$

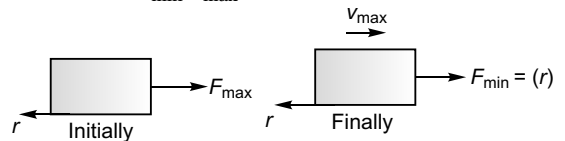

$$P = r v_{max}$$

$$\therefore v_{max} = \frac{P}{r}$$

Objective Questions (Level 1)

Single Correct Option

1. In $KE = \frac{1}{2}mv^2$

m is always +ive and v^2 is +ive.

(even if v is -ive).

\therefore KE is always +ive.

Below reference level (PE = 0) PE is -ive.

\therefore Mechanical energy which is sum of KE and PE may be -ive.

\therefore Correct option is (a).

2. Yes, this is work-energy theorem.

∴ Correct option is (a).

3. On a body placed on a rough surface if an external force is applied the static body does not move then the work done by frictional force will be zero.

$$\begin{aligned}
 4. \quad W &= \vec{\mathbf{F}} \cdot \vec{\mathbf{r}}_{21} \\
 &= \vec{\mathbf{F}} \cdot (\vec{\mathbf{r}}_2 - \vec{\mathbf{r}}_1) \\
 &= (\hat{\mathbf{i}} + 2\hat{\mathbf{j}} + 3\hat{\mathbf{k}}) \cdot [(\hat{\mathbf{i}} - \hat{\mathbf{j}} + 2\hat{\mathbf{k}}) - (\hat{\mathbf{i}} + \hat{\mathbf{j}} + \hat{\mathbf{k}})] \\
 &= (\hat{\mathbf{i}} + 2\hat{\mathbf{j}} + 3\hat{\mathbf{k}}) \cdot (-2\hat{\mathbf{j}} + \hat{\mathbf{k}}) \\
 &= -4 + 3 \\
 &= -1 \text{ J}
 \end{aligned}$$

∴ Correct option is (b).

$$\begin{aligned}
 5. \quad \therefore W &= \int F dx \\
 &= \int_0^5 7 - 2x + 3x^2 dx \\
 &= [7x - x^2 + x^3]_0^5 = 135 \text{ J}
 \end{aligned}$$

∴ Correct option is (d).

$$\begin{aligned}
 6. \quad P &= \vec{\mathbf{F}} \cdot \vec{\mathbf{v}} \\
 &= (10\hat{\mathbf{i}} + 10\hat{\mathbf{j}} + 20\hat{\mathbf{k}}) \cdot (5\hat{\mathbf{i}} - 3\hat{\mathbf{j}} + 6\hat{\mathbf{k}}) \\
 &= 50 - 30 + 120 \\
 &= 140 \text{ W}
 \end{aligned}$$

∴ Correct option is (c).

$$\begin{aligned}
 7. \quad \text{Work done in displacing the body} \\
 &= \text{Area under the curve} \\
 &= (1 \times 10) + (1 \times 5) + (1 \times -5) + \left(\frac{1 \times 10}{2}\right) \\
 &= 15 \text{ J}
 \end{aligned}$$

∴ Correct option is (b).

$$\begin{aligned}
 8. \quad P &= \frac{W}{t} = \frac{mgh + \frac{1}{2}mv^2}{t} \\
 &= \frac{800 \text{ kg} \times 10 \text{ ms}^{-2} \times 10 \text{ m} + \frac{1}{2} \times 800 \text{ kg} \times (20 \text{ ms}^{-1})^2}{1 \text{ min}} \\
 &= \frac{(800 \times 10 \times 10) + [400 \times (20)^2]}{60}
 \end{aligned}$$

$$= \frac{80000 + 160000}{60}$$

$$= 4000 \text{ W}$$

Option (c) is correct.

$$9. \quad x = \frac{t^3}{3}$$

$$\therefore v = \frac{dx}{dt} = t^2$$

$$\text{and } a = \frac{dv}{dt} = 2t$$

$$F = ma = 2 \times 2t = 4t$$

$$W = Fv = 4t \times t^2 = 4t^3$$

∴ Work done by force in first two seconds

$$= \int_{t=0}^{t=2} 4 \cdot t^3 dt$$

$$= 4 \cdot \left[\frac{t^4}{4} \right]_0^2$$

$$= 16 \text{ J}$$

∴ Correct option is (c).

10. Range = $4 \times$ height

$$\text{or } \frac{u^2 \sin 2\theta}{g} = 4 \cdot \frac{u^2 \sin^2 \theta}{2g}$$

$$\text{or } \sin 2\theta = 2 \sin^2 \theta$$

$$\text{or } 2 \sin \theta \cos \theta - 2 \sin^2 \theta = 0$$

$$\text{or } \sin \theta (\cos \theta - \sin \theta) = 0$$

$$\text{or } \cos \theta - \sin \theta = 0 \quad (\text{as } \sin \theta \neq 0)$$

$$\text{or } \tan \theta = 1$$

$$\text{i.e., } \theta = 45^\circ$$

Now, $K = \text{KE}$ at highest point

$$= \frac{1}{2} m (u \cos \theta)^2$$

$$= \frac{1}{2} m u^2 \cos^2 \theta$$

$$= \frac{1}{2} m u^2 \cos^2 45^\circ$$

$$= \frac{1}{2} m u^2 \cdot \frac{1}{2}$$

$$\therefore \frac{1}{2} m u^2 = 2K$$

i.e., Initial KE = $2K$

∴ Correct option is (b).

122 | Mechanics-1

11. $P = 3t^2 - 2t + 1$

i.e., $\frac{dW}{dt} = 3t^2 - 2t + 1$

$$dW = (3t^2 - 2t + 1) dt$$

$$W = \int_2^4 (3t^2 - 2t + 1) dt$$

$$= \left[3 \cdot \frac{t^3}{3} - \frac{2t^2}{2} + t \right]_2^4$$

or $= [t^3 - t^2 + t]_2^4$
 $= (4^3 - 4^2 + 4) - (2^3 - 2^2 + 2)$
 $= 52 - 6$
 $= 46$

$$\Delta K = 46 \text{ J}$$

Correct option is (b).

12. $K_i = \frac{1}{2} \times 10 \times 10^2 = 500 \text{ J}$

Work done by retarding force,

$$W = \int_{20}^{30} -0.1x dx$$

$$= -0.1 \left[\frac{x^2}{2} \right]_{20}^{30}$$

$$= -0.05 \times [(30)^2 - (20)^2]$$

$$= -25 \text{ J}$$

Final kinetic energy $= K_i + W$
 $= 500 + (-25)$
 $= 475 \text{ J}$

∴ Correct option is (a).

13. KE of 12 kg mass : KE of 6 kg mass

$$= \frac{1}{2} m_{12} v^2 : \frac{1}{2} m_6 v^2$$

[Acceleration being same (equal to g) both will have same velocities]

$$= m_{12} : m_6$$

$$= 12 : 6$$

$$= 2 : 1$$

14. $W = \frac{1}{2} k [x_2^2 - x_1^2]$

$$= \frac{1}{2} \times 5 \times 10^3 \left[\left(\frac{10}{100} \right)^2 - \left(\frac{5}{100} \right)^2 \right]$$

$$= \frac{5 \times 10^3}{2 \times 10^4} (100 - 25) = 18.75 \text{ Nm}$$

∴ Correct option is (c).

15. $x = 2.0 \text{ m to } 3.5 \text{ m}$

$$\frac{dU}{dx} = -\frac{6}{1.5} = -4$$

$$\therefore F = +4 \text{ N}$$

$x = 3.5 \text{ m to } 4.5 \text{ m}$

$$\frac{dU}{dx} = \frac{2}{1} = 2$$

$$\therefore F = -2 \text{ N}$$

$x = 4.5 \text{ m to } 5.0 \text{ m}$

$$\frac{dU}{dx} = 0$$

$$\therefore F = 0 \text{ N}$$

Work done $= (4 \times 1.5) + (-2 \times 1) + 0$
 $= 4 \text{ J}$

$$\therefore \frac{1}{2} mv^2 = 4$$

or $\frac{1}{2} \times 1 \times v^2 = 4$

$$\therefore v = 2\sqrt{2} \text{ ms}^{-1}$$

16. KE at highest point

$$= \frac{1}{2} m (u \cos 45^\circ)^2$$

$$= \frac{1}{2} mu^2 \left(\frac{1}{\sqrt{2}} \right)^2$$

$$= \frac{1}{2} \left(\frac{1}{2} mu^2 \right)$$

$$= \frac{E}{2}$$

∴ Correct option is (a).

17. Work done by person

$= -$ [Work done by gravitational pull on rope + gravitational pull on bucket]

$$= \left[\left(-mg \frac{h}{2} \right) + (-Mgh) \right]$$

$$= \left(M + \frac{m}{2} \right) gh$$

∴ Correct option is (a).

18. $\frac{1}{2} mv^2 = Fx$... (i)

$$\frac{1}{2} mv'^2 = Fx'$$
 ... (ii)

$$\therefore \frac{x'}{x} = \frac{v'^2}{v^2} = \frac{(2v)^2}{v^2} = 4 \Rightarrow x' = 4x$$

∴ Correct option is (b).

19. Vertical velocity (initial) = $v_0 \sin \theta$
 At an altitude h
 (vertical velocity)² = $(v_0 \sin \theta)^2 + 2(-g)h$
 (horizontal velocity)² = $(v_0 \cos \theta)^2$
 (Net velocity)² = $v_0^2 - 2gh$
 Net velocity = $\sqrt{v_0^2 - 2gh}$

20. Maximum power will be at 2 s
 velocity (at $t = 2$ second) = $a \cdot 2$

$$= \frac{F}{m} \cdot 2$$

 \therefore Power (at $t = 2$ s) = $F \times \frac{2F}{m} = \frac{2F^2}{m}$
 \therefore Correct option is (d).

21.
$$v = 0 + at$$

$$= at = \frac{F}{m} \cdot t$$

Instantaneous power,

$$P = Fv$$

$$= F \frac{F}{m} \cdot t$$

or
$$P = \frac{F^3}{m} \cdot t$$

or
$$P = \text{constant } t.$$

\therefore Correct option is (b).

22. While ball comes down

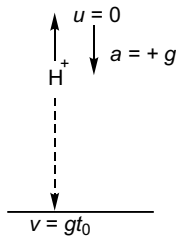

at $t = t_0$ when ball strikes the surface

Using
$$v = u + at$$

$$v = 0 + gt$$

i.e.,
$$v = gt.$$

\therefore
$$\text{KE} = \frac{1}{2}mv^2 = \frac{1}{2}mg^2t^2$$

$$K = \phi t^2$$

where,
$$\phi = \frac{1}{2}mg^2 = \text{constant}.$$

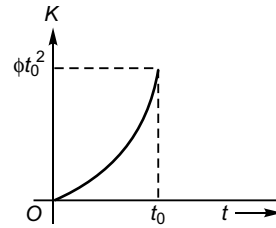
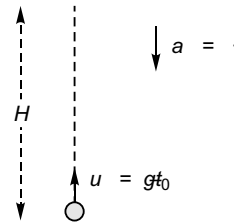

Fig. 1

While ball goes up after elastic collision with the surface it strikes



Using,
$$v = u + at$$

$$v = (-gt_0) + (+g)(t - t_0)$$

$$v = -g(t - 2t_0)$$

\therefore
$$\text{KE} = \frac{1}{2}mg^2(t - 2t_0)^2$$

i.e.,
$$K = \phi(t - 2t_0)^2$$

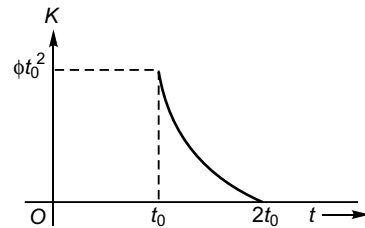

Fig. 2

From the expression for KE

at
$$t = 2t_0, K = 0$$

as shown in Fig. 2.

\therefore Correct option is (b).

23. ρ (block) = 3000 kgm^{-3} and σ (water) = 1000 kgm^{-3}

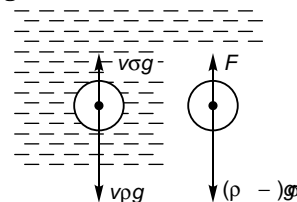

i.e.,
$$\frac{\sigma}{\rho} = \frac{1}{3}$$

(External force applied to move the block upward with constant velocity).

$$\begin{aligned} \text{Work done} &= F s \\ &= v(\rho - \sigma) g s \\ &= v(\rho - \sigma) \times 10 \times 3 \\ &= \frac{5}{\rho}(\rho - \sigma) \times 10 \times 3 \quad (\because v\rho = 5) \\ &= 5\left(1 - \frac{\sigma}{\rho}\right) \times 10 \times 3 \\ &= 5\left(1 - \frac{1}{3}\right) \times 10 \times 3 = 100 \text{ J} \end{aligned}$$

\therefore Correct option is (a).

24.
$$p_{\text{av}} = \frac{\text{Net work done}}{\text{Time of flight } (T)}$$

$$= \frac{mgH \cos \pi + mgH \cos 0}{T}$$

H = Maximum height attained by the projectile

$$= \frac{(0)}{T} = \text{zero}$$

25.
$$W(a) = \frac{1}{2} 2k'(x)^2$$

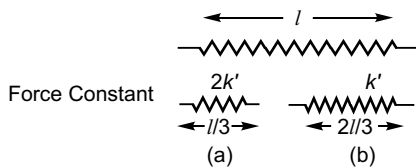

$$W(b) = \frac{1}{2} k'(x)^2$$

$\therefore W(a) > W(b)$

\therefore Correct option is (c).

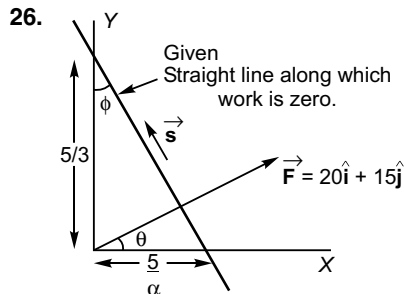

$$\begin{aligned} 3y + \alpha x &= 5 \\ \frac{y}{5/3} + \frac{x}{5/\alpha} &= 1 \end{aligned}$$

From above figure

$$\tan \theta = \frac{15}{20} = \frac{3}{4}$$

Work done will be zero, if

$$\phi = \theta$$

i.e., $\tan \phi = \tan \theta$

or
$$\frac{5/\alpha}{5/3} = \frac{3}{4}$$

or
$$\frac{3}{\alpha} = \frac{3}{4}$$

$\Rightarrow \alpha = 4$

\therefore Correct option is (d).

27. Let x be the elongation in the spring.

Increase in PE of spring = Decrease in PE of block

$$\therefore \frac{1}{2} k x^2 = mgx \sin \theta$$

$$\Rightarrow x = \frac{2mg \sin \theta}{k}$$

\therefore Correct option is (a).

28.
$$\vec{s} = 2t^2 \hat{i} - 5 \hat{j}$$

$$\therefore \vec{ds} = 4t \hat{i} dt$$

$$\begin{aligned} W &= \int \vec{F} \cdot \vec{ds} \\ &= \int_0^2 (3t \hat{i} + 5 \hat{j}) \cdot 4t \hat{i} dt \\ &= \int_0^2 12t^2 dt \\ &= \left[12 \frac{t^3}{3} \right]_0^2 \\ &= [4t^3]_0^2 \\ &= 32 \text{ J} \end{aligned}$$

\therefore Correct option is (b).

29.
$$W = mgh + mgd$$

$$= mg(h + d)$$

or
$$F_{\text{av}} d = mg(h + d)$$

$$\therefore F_{\text{av}} = mg \left(1 + \frac{h}{d} \right)$$

30. Energy stored in A = $E = \frac{1}{2} k_A x_A^2$

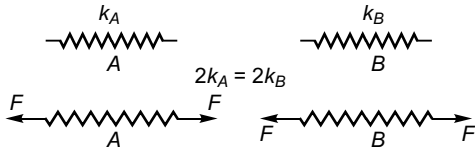

$$= \frac{1}{2} k_A \left(\frac{F}{k_A} \right)^2$$

$$= \frac{F^2}{2k_A}$$

Energy stored in B = $\frac{F^2}{2k_B}$

$$= \frac{F^2}{4k_A} \quad (\because k_B = 2k_A)$$

$$= \frac{1}{2} \frac{F^2}{2k_A} = \frac{E}{2}$$

\therefore Correct option is (a).

31. $\frac{1}{2} kx^2 = \frac{1}{2} mv^2$

$$x = v \sqrt{\frac{m}{k}}$$

$$= 1.5 \sqrt{\frac{0.5}{50}} = 0.15 \text{ m}$$

\therefore Correct option is (a).

32. $\frac{1}{2} mv^2 = F(2x)$... (i)

$$\frac{1}{2} m(2v)^2 = F(nx)$$
 ... (ii)

Dividing Eq. (i) by Eq. (ii),

$$\frac{(2v)^2}{v^2} = \frac{n}{2}$$

$$\Rightarrow n = 8$$

\therefore Correct option is (d).

33. $mgh = \frac{1}{2} mv^2 + \frac{1}{2} kx^2$

i.e., $v^2 = \sqrt{2gh - \frac{k}{m} h^2}$

$$= \sqrt{2 \times 10 \times 0.15 - \frac{10}{0.1} \times (0.15)^2}$$

or $v = 0.866 \text{ m s}^{-1}$

\therefore Correct option is (b).

34. Decrease in PE of mass m

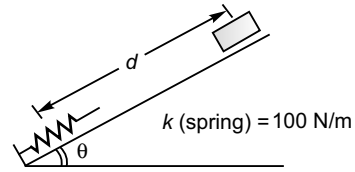

= Increase in PE of spring

i.e., $mgd \sin \theta = \frac{1}{2} kx^2$

or $d = \frac{kx^2}{2mg \sin \theta}$

$$= \frac{100 \times 2^2}{2 \times 10 \times 10 \times \sin 30^\circ} = 4 \text{ m.}$$

\therefore Correct option is (c).

35. PE of block will change into its KE and then the KE gained by the block will change into the PE of the spring.

Due to inertia the spring will not start compressing the moment the block just touches the spring and as such the block will still be in the process as increasing its KE. Thus v of the block will be maximum when it compresses the spring by some amount.

\therefore Correct option is (b).

36. Work done by normal force is zero, being perpendicular to the displacement.

Work done by string is $+mgh$ while that due to gravity it is $-mgh$.

Net work done = $(+mgh) + (-mgh)$

$$= 0$$

\therefore Correct option is (c).

37. Work done on floor = 0 (as displacement is zero).

38. Acceleration = $\frac{(0 - 20) \text{ ms}^{-1}}{(10 - 0) \text{ s}}$

$$= -2 \text{ ms}^{-2}$$

Therefore, net force on particle

$$= 2 \text{ kg} \times -2 \text{ m s}^{-2}$$

$$= -4 \text{ N}$$

i.e., the net force on the particle is opposite to the direction of motion.

\therefore Correct option is (a).

$$\begin{aligned} \text{Net work done} &= F \times s \\ &= F \times (\text{Area under } v-t \text{ graph}) \\ &= -4 \times \left(\frac{1}{2} \times 20 \times 10 \right) = -400 \text{ J} \end{aligned}$$

Thus net work done may not be wholly due to frictional force only.

Further net force -4 N may not be wholly due to friction only.

39. Height of bounce = $(100 - 20)\%$ of 10 m
 $= 8$

\therefore Correct option is (c).

$$\text{KE just before bounce} = \frac{1}{2}mv^2 = mgh$$

KE just after bounce = 80% of mgh

When the ball attains maximum height after bounce

$$\text{Gain in PE} = mgh' = \text{Loss of KE}$$

$$\text{or } mgh' = 80\% \text{ of } mgh$$

$$\text{or } h' = 80\% \text{ of } h = 80\% \text{ of } 10 \text{ m} \\ = 8 \text{ m}$$

JEE Corner

Assertion and Reason

1. $P = Fv$

For power to be constant, the velocity must also be constant. Thus, assertion is false.

According to 2nd law of motion, net constant force will always produce a constant acceleration. Reason is true.

\therefore Correct option is (d).

2. As displacement is opposite to force (reason) the work done by force will be negative.

Thus, Assertion is true. Further, as reason is the correct explanation of the Assertion.

\therefore Correct option is (a).

3. Conservative force has nothing to do with kinetic energy. (If a non-conservative force acts on a particles, there would be loss of KE). Thus, assertion is false.

Work done by conservative force decreases PE (reason is true).

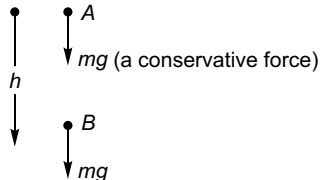

$$W = mgh$$

If PE at A is zero.

The PE at B would be $-mgh$.

\therefore Correct option is (d).

4. In circular motion only the work done by The centripetal force is zero. Assertion is false, centripetal force acts towards centre while the velocity acts tangentially.

Reason is true.

\therefore Correct option is (d).

5. As the speed is increasing (slope of graph being increasing) there must be net force in the +ive direction of displacement.

Thus, work done to all forces will be positive, Assertion is true and also as explained above reason besides being true is the correct explanation for the Assertion.

\therefore Correct option is (a).

6. Work done by constant force \vec{F} when the body shifts from A to B.

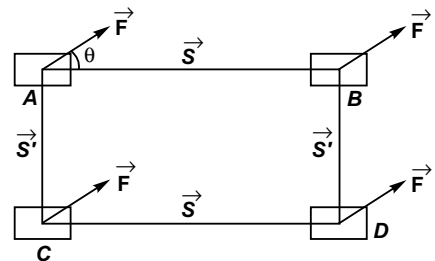

$$W_{AB} = \vec{F} \cdot \vec{s} = F s \cos \theta$$

Similarly, $W_{AC} = \vec{F} \cdot \vec{s}$

$$= F s' \cos (90^\circ + \theta)$$

$$= -F s' \sin \theta$$

$$W_{CD} = \vec{F} \cdot \vec{s} = F s \cos \theta$$

$$W_{DB} = \vec{F} \cdot \vec{s} \cos(90^\circ - \theta)$$

$$= F s' \sin \theta$$

$$W_{AC} + W_{CD} + W_{DB} = F s \cos \theta = W_{AB}$$

∴ Work done by a constant force is path independent. thus, Assertion is true.

The Reason is false. Kinetic frictional force remains constant but is a non-conservative force.

∴ Correct option is (c).

7. It is true that work-energy theorem can be applied to non-inertial frame also as explained in the answer to question no. 2 of introductory exercise 6.2.

Earth is non-inertial which is also true is a separate issue and has nothing to do with the assertion.

Thus, option (b) would be the answer.

8. When block is depressed the excess of upthrust force will act as restoring force and will bring the block up. The velocity gained by block will take the block above its equilibrium and the block will oscillate about its equilibrium position (as given in reason). Thus, the block will be in equilibrium in the vertical direction. Thus, assertion is also true and the reason being correct explanation of the assertion.

∴ Correct option is (a).

9. As displacement ($= s_2 - s_1$) is not equal to zero, the work done by all forces may not be zero. Therefore, assertion is false.

Work done by all the forces is equal to change in KE is as per work-energy theorem. Thus, reason is true.

∴ Correct option is (d).

10. When the block comes down the wedge, the wedge will move towards left and the actual displacement of normal force will not be along the wedge (see chapter on CM). It will along AB as shown in figure. Thus, the angle between N (normal force on block) and its displacement AB will be

greater than 90° and that between N (normal force on wedge) and its displacement will be less than 90° as given in reason.

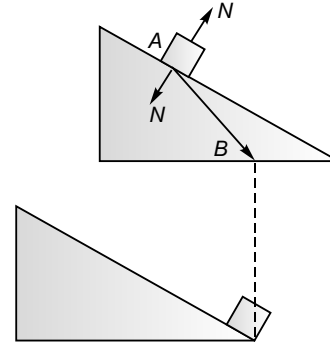

For this the work done by N (or block) will be negative and that by N (on wedge) will be positive as given in assertion.

Reason also being the correct explanation of the assertion.

11. There will be increase in length of the elastic cord.

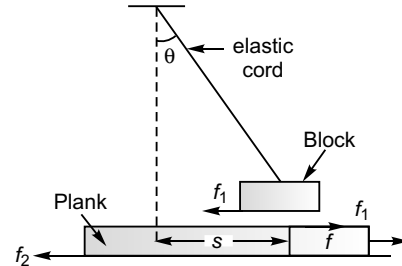

Work-done by static force

$$f_1 \text{ (on block)} = - f_1 s$$

Work done by static force

$$f_1 \text{ (on plank)} = + f_1 s$$

∴ Work done by static force f_1 on the system (block + plank + cord) = 0

Thus, reason is true.

The work done by the force F will be used up in doing work against friction f_2 and also increasing the elastic potential energy of the cord. Thus, assertion is true.

Further, as the reason is the correct explanation of the assertion.

12. Decrease in KE = $\frac{1}{2}mv^2 - 0$

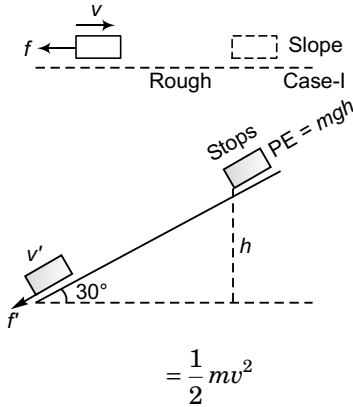

Change in mechanical energy

Objective Questions (Level 2)

Single Correct Option

1. Increase in KE of bead = Work done by gravity + work done by force F

$$\therefore \frac{1}{2}mv^2 = mgh + FR$$

(Displacement of force F is R)

$$= \frac{1}{2} \times 10 \times 5 + 5 \times 5 = 50$$

$$\therefore u = \sqrt{\frac{100}{m}}$$

$$= \sqrt{200} = 14.14 \text{ ms}^{-1}$$

\therefore Correct option is (a).

2. $P = Fv$

$$= mav$$

$$= m \left(v \frac{dv}{dx} \right) v \left(a = \frac{dv}{dt} = \frac{dv}{ds} \cdot \frac{ds}{dt} = v \frac{dv}{ds} \right)$$

$$\therefore ds = \frac{m}{p} v^2 dv$$

$$\text{i.e., } \int ds = \frac{m}{p} \int_v^{2v} v^2 dv$$

$$\text{or } s = \frac{m}{p} \left[\frac{v^3}{3} \right]_v^{2v}$$

$$= \frac{m}{3p} [(2v)^3 - (v)^3] = \frac{7mv^3}{3p}$$

\therefore Correct option is (a).

$$PE + KE = \frac{1}{2}mv^2$$

Decrease in ME is used up in doing work against friction.

In this case the mechanical energy is being used up in doing work against friction and in increasing the PE of the block.

$$\therefore \text{Change ME} = \frac{1}{2}mv^2 - mgh$$

Thus, assertion is true.

As explained above the reason is false.

(μ does not change with the increase in angle of inclination)

\therefore Correct option is (c).

3. Loss of PE of block = Gain in PE of spring

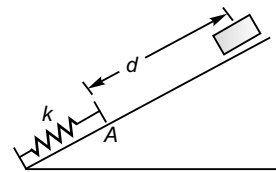

$$mg(d+2)\sin 30^\circ = \frac{1}{2}k \times 2^2$$

$$\text{or } 10 \times 10 \times (d+2) \times \frac{1}{2} = \frac{1}{2} \times 100 \times 2^2$$

$$d = 2 \text{ m}$$

Let, v_A = velocity of block when it just touches spring

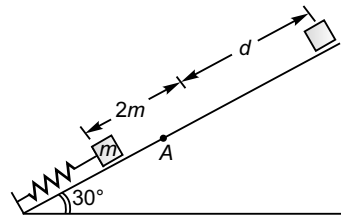

$$\therefore \frac{1}{2}mv_A^2 = mgd \sin 30^\circ$$

$$v_A^2 = 10 \times 2 \times 2 \times \frac{1}{2}$$

$$v_A = \sqrt{20} \text{ ms}^{-1}$$

Correct option is (a).

4. Mass per unit length of chain = $\frac{m}{\pi R/2}$

$$dm = R d\theta \frac{m}{\pi R/2}$$

$$y_{CM} = \frac{\int y dm}{\int dm}$$

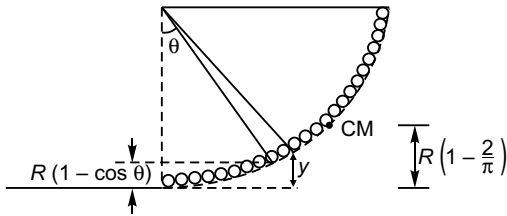

$$= \frac{\int_0^{\pi/2} R(1 - \cos \theta) \frac{m}{\pi R/2} R d\theta}{m}$$

$$= \frac{2R}{\pi} \int_0^{\pi/2} (1 - \cos \theta) d\theta$$

$$= \frac{2R}{\pi} \left[\frac{\pi}{2} - 1 \right]$$

$$= R \left[1 - \frac{2}{\pi} \right]$$

Now, $\frac{1}{2}mv^2 + mg y_{CM}$

or $v^2 = 2g y_{COM}$
 $v = \sqrt{2gR \left(1 - \frac{2}{\pi} \right)}$

∴ Correct option is (c).

5. The moment string is cut

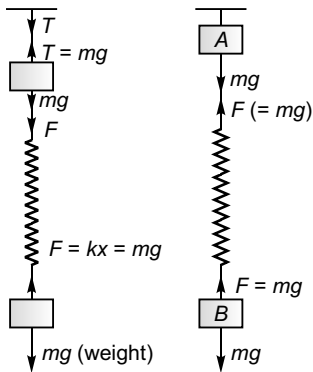

Net force on A = $2mg$ (downward)

∴ $a_1 = 2g$

Net force on B = 0

∴ $a_2 = 0$

∴ Correct option is (b).

6. Let x be the expansion in the spring.

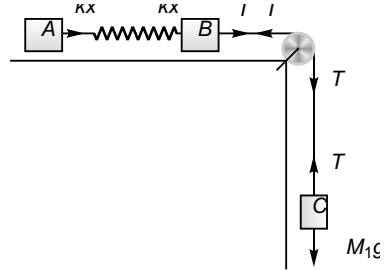

Increase in PE of spring = Decrease in PE of block C

$$\frac{1}{2}kx^2 = M_1gx$$

i.e., $kx = 2M_1g$

For block A to remain at rest

$$kx = \mu_{\min} Mg$$

or $2M_1g = \mu_{\min} Mg$

∴ $\mu_{\min} = \frac{2M_1}{M}$

∴ Correct option is (c).

7. $T_i = mg$

$$KX_i = \frac{2mg}{2} = mg$$

When one spring is cut. It means KX_i becomes zero. Downward acceleration,

$$a = \frac{KX_i}{2m} = \frac{mg}{2m} = \frac{g}{2}$$

Now drawing FBD of lower mass :

$$mg - T_f = m \cdot a = \frac{mg}{2}$$

∴ $T_f = \frac{mg}{2}$

or $\Delta T = T_f - T_i = \frac{mg}{2}$

8. $a = \frac{mg \sin \theta - \mu mg \cos \theta}{m}$

$$= g \sin \theta - \mu g \cos \theta$$

For v to be maximum

$$\frac{dv}{dx} = 0$$

or $v \frac{dv}{dx} = 0$

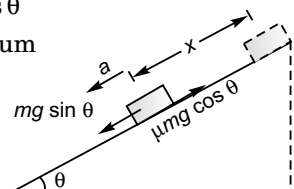

130 | Mechanics-1

or $\frac{dx}{dt} \cdot \frac{dv}{dx} = 0$

or $\frac{dv}{dt} = 0$

or $a = 0$

i.e., $g \sin \theta = \mu g \cos \theta$

or $\sin \theta = \mu \cos \theta$

or $\frac{3}{5} = \frac{3}{10} x \cdot \frac{4}{5}$

$\Rightarrow x = \frac{10}{4} = 2.5 \text{ m}$

\therefore Correct option is (d).

9. (a) Between points E and F , $\frac{dU}{dr}$ is - ive.

Now, $F = -\frac{dU}{dr}$, the force between E and F will be + ive i.e., repulsive.

(b) At point C the potential energy is minimum. Thus, C is point of stable equilibrium.

\therefore Correct option is (c).

10. Power = $\vec{F} \cdot \vec{v}$

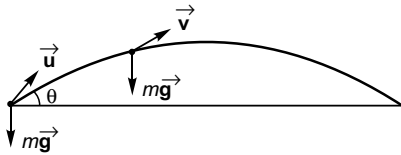

$= m \vec{g} \cdot (\vec{u} + \vec{g} t)$

$= mg u \cos (90^\circ + \theta) + m \vec{g} \cdot \vec{g} t$

i.e., $P = -mg u \sin \theta + mg^2 t$

$[|\vec{u}| = u, |\vec{g}| = g]$

Therefore, the graph between P and t will be as shown in option (c).

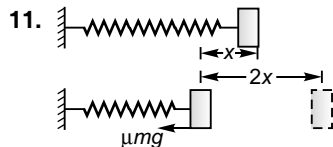

PE of spring due to its compression by x

= | Work done by frictional force when displaced by $2x$ |

i.e., $\frac{1}{2} kx^2 = \mu mg 2x$

$\Rightarrow x = \frac{4 \mu mg}{k}$

\therefore Correct option is (c).

12. Power delivered by man = $\vec{T} \cdot \vec{v}$

$= T v \cos \theta$

$|\vec{T}| = T$

and $|\vec{v}| = T$

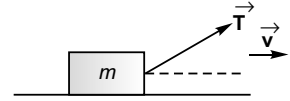

13. $\phi = 3x + 4y$

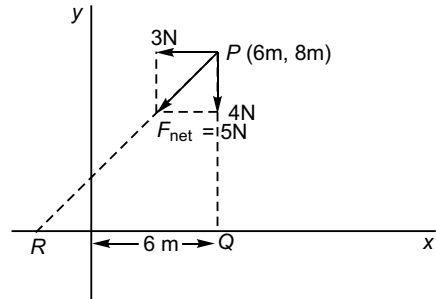

$\therefore F_x = -\frac{\partial \phi}{\partial x} = -3 \text{ N}$

and $F_y = -\frac{\partial \phi}{\partial y} = -4 \text{ N}$

$\frac{PR}{PQ} = \frac{5}{4}$

$\Rightarrow PR = \frac{5}{4} \times PQ = 10 \text{ m}$

\therefore Work done by the conservative force on the particle

$= F_{\text{net}} \times PR = 5 \text{ N} \times 10 \text{ m}$

$= 50 \text{ Nm} = 50 \text{ J}$

\therefore Correct option is (c).

14. Both at $x = x_1$ and $x = x_2$ the force acting on the body is zero i.e., it is in equilibrium.

Now, if the body (when at $x = x_1$) is moved towards right (i.e., $x > x_1$) the force acting on it is + ive i.e., the body will not come back and if the body (when at $x = x_2$) is moved toward right (i.e., $x > x_2$) the force acting on it is - ive i.e., the body will return back. Then, $x = x_2$ is the position of stable equilibrium.

\therefore Correct option is (b).

15. The man will stop when

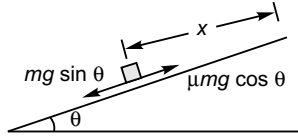

$$\mu mg \cos \theta = mg \sin \theta$$

or $(\mu_0 x) mg \cos \theta = mg \sin \theta$
 or $x = \frac{\tan \theta}{\mu_0}$

16. Taking moment about A

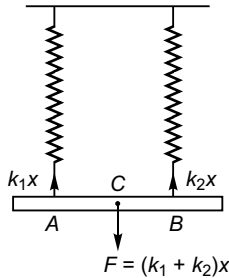

$$AC \cdot F = (k_2 x) l$$

$\therefore AC = \frac{(k_2 x) l}{F}$
 $= \frac{(k_2 x) l}{(k_1 + k_2)x}$
 $= \frac{k_2}{k_1 + k_2} l$

\therefore Correct option is (d).

17. mgh + work done by the force of friction

$$= \frac{1}{2} mv^2$$

\therefore Work done by the force of friction

$$= \frac{1}{2} mv^2 - mgh$$

$$= \left(\frac{1}{2} \times 1 \times 2^2 \right) - (1 \times 10 \times 1)$$

$$= -8\text{J}$$

\therefore Correct option is (c).

18. $U = \frac{a}{x^{12}} - \frac{b}{x^6}$

$$U = ax^{-12} - bx^{-6}$$

For stable equilibrium, $\frac{dU}{dx} = 0$

i.e., $a(-12)x^{-13} - b(-6)x^{-7} = 0$

i.e., $6bx^{-7} = 12ax^{-12}$

i.e., $x = \left(\frac{2a}{b} \right)^{\frac{1}{6}}$

\therefore Correct option is (a).

19. For the rotational equilibrium of the rod

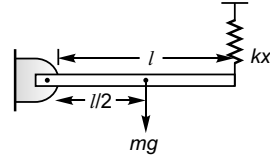

$$mg \cdot \frac{l}{2} = kx l$$

i.e., $x = \frac{mg}{2k}$

\therefore PE stored in the spring $= \frac{1}{2} kx^2$

$$= \frac{1}{2} k \left(\frac{mg}{2k} \right)^2 = \frac{(mg)^2}{8k}$$

\therefore Correct option is (c).

20. $a = \frac{m_1 - m_2}{m_1 + m_2} g$

Speed (v) with which mass m_1 strikes the floor

$$= \sqrt{0^2 + 2gh} = \sqrt{2 \left(\frac{m_1 - m_2}{m_1 + m_2} \right) gh}$$

\therefore Correct option is (a).

21. $F = -ax + bx^2$

$\therefore -\frac{dU}{dx} = -ax + bx^2$

or $dU = (ax - bx^2) dx$

or $U = \int (ax - bx^2) dx$

or $U = \frac{ax^2}{2} - \frac{bx^3}{3} + c$

At $x = 0$, $F = 0$

$\therefore U = 0$

and so, $c = 0$

Thus, $U = \frac{ax^2}{2} - \frac{bx^3}{3}$

$U = 0$, when $\frac{ax^2}{2} = \frac{bx^3}{3}$

i.e., at $x = \frac{3a}{2b}$

132 | Mechanics-1

$$\frac{dU}{dx} = 0, \text{ when } F = 0$$

$$\text{i.e., } -ax + bx^2 = 0$$

$$\text{i.e., at } x = \frac{a}{b}$$

Graph between U and x will be

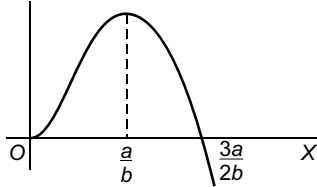

∴ Correct option is (c).

22. $\frac{W_A}{W_B} = \frac{Fs}{Fs} = 1$

∴ Correct option is (c).

$$\frac{W_A}{W_B} = \frac{\frac{1}{2}mv_A^2}{\frac{1}{2}4mv_B^2} = 1$$

$$\Rightarrow \frac{v_A^2}{v_B^2} = \frac{4}{1}$$

$$\Rightarrow \frac{v_A}{v_B} = \frac{2}{1}$$

$$\frac{W_A}{W_B} = \frac{1}{1}$$

$$\therefore \frac{K_A}{K_B} = \frac{1}{1}$$

23. U_i at $(1, 1) = k(1 + 1) = 2k$

$$U_f \text{ at } (2, 3) = k(2 + 3) = 5k$$

$$W = U_f - U_i = 5k - 2k = 3k$$

∴ Correct option is (b).

24. Gain in PE of spring = Loss of PE of block

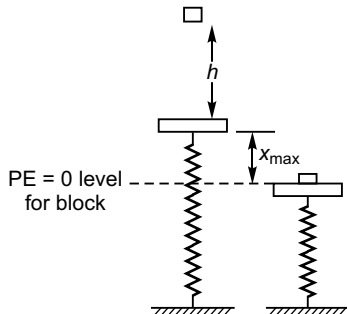

$$\therefore \frac{1}{2}kx_{\max}^2 = mg(h + x_{\max}) \quad \dots(i)$$

∴ From above Eq. (i),

x_{\max} depends upon h and also x_{\max} depends upon k .

KE of the block will be maximum when it is just at the point of touching the plank and at this moment there would be no compression in the spring.

$$\text{Maximum KE of block} = mgh$$

∴ Correct option is (c).

25. Gain in KE of chain = Decrease in PE of chain

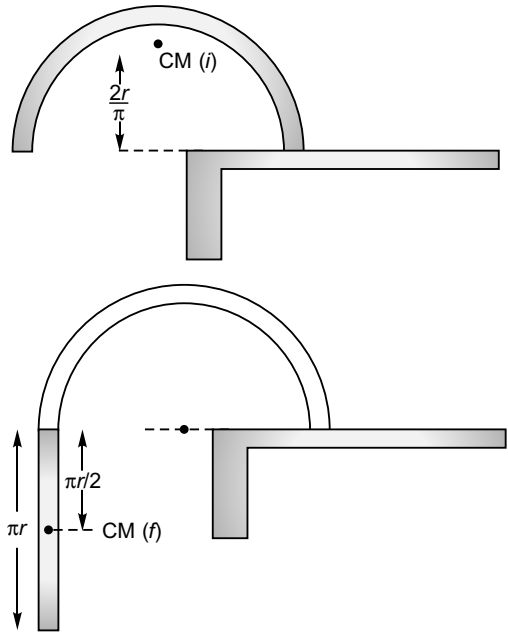

When the whole chain has just come out of the tube.

$$\text{or } \frac{1}{2}mv^2 = mg\left(\frac{2\pi}{\pi} + \frac{\pi r}{2}\right)$$

$$\therefore v = \sqrt{2gr\left(\frac{2}{\pi} + \frac{\pi}{2}\right)}$$

∴ Correct option is (b).

26. Acceleration of the block will decrease as the block moves to the right and spring expands the velocity (v) of block will be maximum, when

$$\frac{1}{2}mv^2 = \frac{1}{2}kx^2$$

At this moment, $F = kx$

i.e., $x = \frac{F}{k}$

or $v^2 = \frac{k}{m} \left(\frac{F}{k}\right)^2 = \frac{F^2}{km}$

$\therefore v = \frac{F}{\sqrt{mk}}$

\therefore Correct option is (b).

27. Force on each block = kx



$$= 200 \times \frac{1}{10} = 20 \text{ N}$$

Power of A = $20 \times 4 = 80 \text{ W}$

Power of B = $20 \times 6 = 120 \text{ W}$

\therefore Total power = 200 W

i.e., rate of energy transfer = 200 Js^{-1}

\therefore Correct option is (c).

28. From O to x compression in the spring



Average acceleration of A

$$a_A = \frac{kx - F}{2m}$$

Average acceleration of B

$$a_B = \frac{kx}{2(3m)}$$

As at maximum compression of the spring both the blocks would be having same velocity.

$$2a_A x = 2a_B x \quad [\text{using } v^2 = u^2 + 2as]$$

i.e., $\frac{kx - F}{2m} = \frac{kx}{6m}$

or $kx - F = \frac{kx}{3}$

or $F = \frac{2kx}{3}$

i.e., $x = \frac{3F}{2k}$

\therefore Correct option is (c).

29. Work done on block A in ground frame

$$= 0.2 \times 45 \times 10 \times \frac{(50 - 30)}{100}$$

$$= 18 \text{ J}$$

\therefore Correct option is (b).

30. $N = mg \cos \theta$

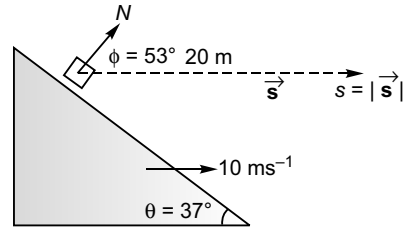

$$= 10 \times 10 \times \cos 37^\circ$$

$$= 10 \times 10 \times \frac{4}{5}$$

$$= 80 \text{ N}$$

\therefore Work done by N in 2 s

$$= N \cos \phi$$

$$= 80 \times 20 \times \cos 53^\circ$$

$$= 80 \times 20 \times \frac{3}{5}$$

$$= 960 \text{ Nm}$$

$$= 960 \text{ J}$$

\therefore Correct option is (b).

31. $\frac{T' + mg}{m} = 5$

(given)

Upper spring cut

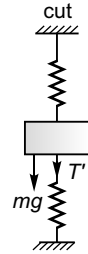

Initially

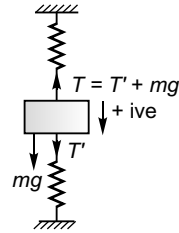

Lower spring cut

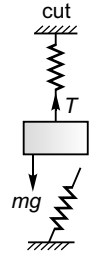

$$T' + m \times 10 = 5m$$

i.e., $T' = -5m$

$$a = \frac{mg - T}{m}$$

$$= \frac{mg - (T' + mg)}{m}$$

$$= -\frac{T'}{m}$$

$$= -\frac{(-5m)}{m}$$

$$= 5 \text{ ms}^{-2}$$

∴ Correct option is (b).

32. Total ME = 25 J

∴ PE (U)_{max} = 25 J [as KE can't be -ive.]

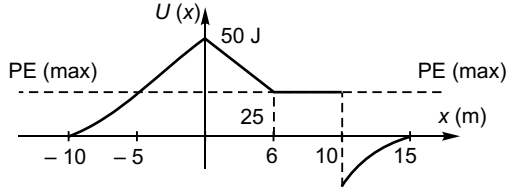

Particle can't be found in the region above PE (max) line.

∴ $-10 < x < -5$ and $0 < x < 15$

∴ Correct option is (a).

More than One Correct Options

1. (i) Acceleration

$$U = 7x + 24y$$

$$\therefore F_x = -\frac{\partial U}{\partial x} = -7$$

$$F_y = -\frac{\partial U}{\partial y} = -24$$

i.e., $a_x = -\frac{7}{5}$

i.e., $a_y = -\frac{24}{5}$

$$\therefore \vec{a} = -\frac{7}{5}\hat{i} - \frac{24}{5}\hat{j} \text{ m/s}^2$$

i.e., $|\vec{a}| = 5 \text{ ms}^{-2}$

∴ Correct option is (b).

(ii) Velocity at $t = 4$ s

$$\vec{v} = \vec{u} + \vec{a} t$$

$$= (8.6\hat{i} + 23.2\hat{j}) + \left[-\frac{7}{5}\hat{i} - \frac{24}{5}\hat{j}\right] 4$$

$$= 8.6\hat{i} + 23.2\hat{j} - 5.6\hat{i} - 10.2\hat{j}$$

$$= 3\hat{i} + 4\hat{j}$$

$$\therefore |\vec{v}| = 5 \text{ ms}^{-1}$$

∴ Correct option is (a).

33. Total ME = - 40 J

∴ PE (max) = - 40 J

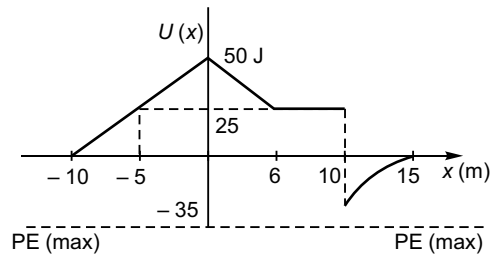

Particle can't be found in the regions above PE (max) line.

∴ "It is not possible". Option (d).

(iii) As $\vec{a} \cdot \vec{v} \neq 0$, the path of the particle can't be a circle.

i.e., \vec{a} is not perpendicular to \vec{v} .

Options (c) and (d) are incorrect.

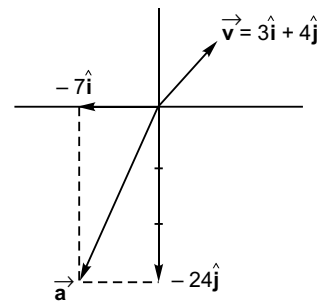

2. $U = 100 - 5x + 100x^2$

$$\therefore F_x = -\frac{\partial U}{\partial x} = -\frac{\partial}{\partial x}(100 - 5x + 100x^2)$$

$$= -[-5 + 200x]$$

$$= 5 - 200x$$

$$\therefore a_x = \frac{F_x}{0.1} = \frac{5 - 200x}{0.1}$$

$$= 50 - 2000x$$

(i) At 0.05 m from origin

$$x = +0.05 \text{ m}$$

(first point)

$$a_x = 50 - 2000(0.05)$$

$$= 50 - 100$$

$$= -50 \text{ m/s}^2$$

$$= 50 \text{ m/s}^2 \text{ towards -ive } x$$

∴ Correct option is (a).

(ii) At 0.05 m from origin

$$x = -0.05 \text{ m} \quad (\text{second point})$$

$$a_x = 50 - 2000(-0.05)$$

$$= 50 + 100$$

$$= 150 \text{ m/s}^2$$

∴ Correct option is (c).

Mean Position

$$a = 0 \text{ at } x = \frac{50}{2000} \text{ m} = 0.025 \text{ m}$$

(iii) For point 0.05 m from mean position

$$x = (0.05 + 0.025) \text{ m}$$

$$= 0.075 \text{ m}$$

$$\therefore a_x \text{ (at } x = 0.075 \text{ m)} = 50 - 2000(0.075)$$

$$= 50 - 150 = -100 \text{ m/s}^2$$

$$= 100 \text{ m/s}^2 \text{ towards -ve } x\text{-axis.}$$

∴ Correct option is (b).

(iv) For second point 0.05 m from mean position

$$x = 0.025 \text{ m} - 0.05 \text{ m}$$

$$= -0.025 \text{ m}$$

$$\therefore a_x = 50 - 2000(-0.025)$$

$$= 100 \text{ ms}^{-2}$$

∴ Option (d) is incorrect.

3. (i) If the spring is compressed by x , elastic potential energy equal to $\frac{1}{2}kx^2$ gets stored

in the spring. Now, if the compressed spring is released the energy stored in the spring will be lost. When the spring attains to natural length.

Work done by spring = Energy stored in the spring

$$= \frac{1}{2}kx^2$$

∴ Correct option is (a).

(ii) If the spring is extended by x , energy stored in the spring would be $\frac{1}{2}kx^2$. If the

extended spring is released the energy stored in the spring will be lost when the spring attains its natural length.

Work done by spring = Energy stored in the spring

$$= \frac{1}{2}kx^2$$

∴ Correct option is (b).

(iii) If spring is initially its natural length and finally compressed.

Work done on (not by) the spring $\left(= \frac{1}{2}kx^2 \right)$

will be stored in the spring.

∴ Option (c) is incorrect.

(iv) If spring is initially at its natural length and finally extended.

Work done on (not by) the spring $\left(= \frac{1}{2}kx^2 \right)$

will be stored in the spring.

∴ Option (d) is incorrect.

4. (i) Work-Energy theorem states that W_{net} (Work done by all forces conservative or non-conservative, external or internal)

$$= \Delta (\text{KE})$$

Correct option is (d) is incorrect.

∴ Correct option is (c).

(ii) Work done by non-conservative forces (*i.e.*, all forces except conservative forces) lead to decrease in KE and thus change in mechanical energy takes place.

∴ Correct option is (b).

(iii) Work done by a conservative force may be + ve, - ve or zero.

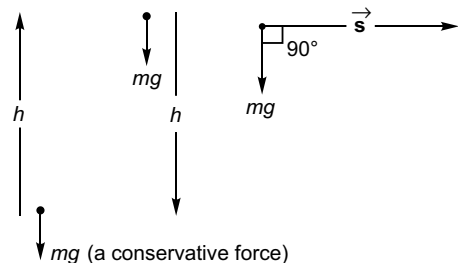

$$W = m \vec{g} \cdot \vec{h}$$

$$= mgh \cos \pi$$

$$= -mgh$$

(PE increases)

$$\begin{aligned}
 W &= m \vec{g} \cdot \vec{h} \\
 &= mgh \cos 0 \\
 &= + mgh
 \end{aligned}$$

(PE increases)

$$W = m \vec{g} \cdot \vec{h} = mgh \cos \frac{\pi}{2} = 0$$

(PE remains same)

Option (a) is incorrect.

5. F is the force by hand or upper disc

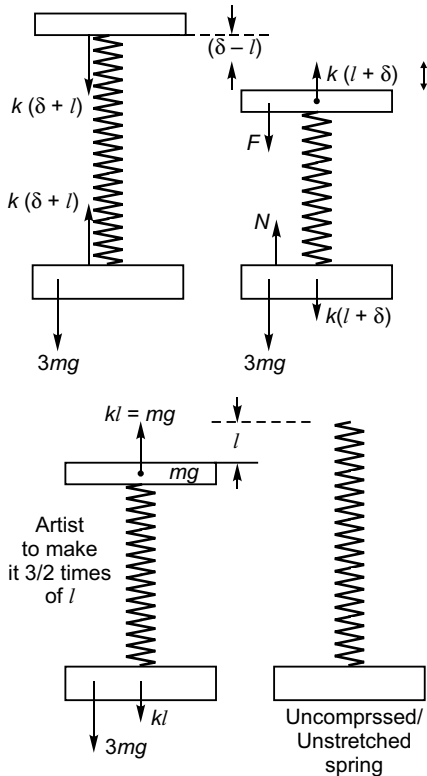

$$\begin{aligned}
 N &= 3mg + k(l + \delta) \\
 &= 3mg + k\left(l + \frac{2mg}{k}\right) \\
 &= 3mg + kl + 2mg \\
 &= 3mg + mg + 2mg \\
 &= 6mg \quad \left(\text{for } \delta = \frac{2mg}{k}\right)
 \end{aligned}$$

∴ Correct option is (b).

$$\begin{aligned}
 N &= kl + 3mg \\
 &= mg + 3mg = 4mg
 \end{aligned}$$

∴ Correct option is (c).

When F is removed, the upper disc accelerates upwards and when it attains the position as in figure 2, its acceleration reduces to zero and the velocity gained by it takes it further upwards. Restoring force on the upper plate now acts downwards and that on the lower plate acts in the upward direction and would lift it (lower plate) if

$$k(\delta - l) > 3mg$$

i.e.,

$$k\delta > 3mg + kl$$

or

$$k\delta > 3mg + mg$$

or

$$\delta > \frac{4mg}{k}$$

∴ Correct option is (d).

Correct option is (a) obviously being incorrect.

6. At maximum extension x :

decrease in potential energy of B = increase in spring energy

$$\therefore (2m)(g)(x) = \frac{1}{2} kx^2$$

or

$$k = \frac{4mg}{x}$$

7. Total work done by internal forces of a system, which constitute action and reaction pairs, is always zero and if it is not so the total work done will not zero.

∴ Correct options are (b) and (c).

8. (i) Work done by conservative forces may be + ive, - ive or zero as explained in the answer to question no. 4

∴ Option (a) is incorrect.

Correct option is (b).

Correct option is (c).

(ii) In pure rolling work done by frictional force (a non-conservative force) is always zero.

∴ Correct option is (d).

9. In moving from 1 to 2 work done by conservative force

$$\begin{aligned}
 &= U_1 - U_2 \\
 &= (-20) - (-10) \\
 &= -10 \text{ J}
 \end{aligned}$$

∴ Option (a) is incorrect.

Option (b) is correct.

Work done by all forces

$$\begin{aligned} &= (K_2 + U_2) - (K_1 + U_1) \\ &= [20 + (-10)] - [10 + (-20)] \\ &= 20 \text{ J} \end{aligned}$$

∴ Correct option is (c).

Option (d) is incorrect.

10.

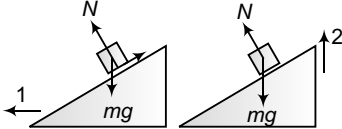

Work done by gravity

In motion 2 → -ive [as $\theta = \pi$]

In motion 1 → zero [as $\theta = \frac{\pi}{2}$]

∴ Correct option is (a).

Match the Columns

1. As body is displaced from $x = 4 \text{ m}$ to $x = 2 \text{ m}$

$$\vec{s} = -2 \hat{i} \text{ m}$$

(a) $\vec{F} = 4 \hat{i}$

∴ $W = \vec{F} \cdot \vec{s} = 4 \hat{i} \cdot (-2 \hat{i}) = -8 \text{ unit}$

(a) → (q)
and $|W| = 8 \text{ unit}$

(a) → (s)

(b) $\vec{F} = 4 \hat{i} - 4 \hat{j}$

∴ $W = \vec{F} \cdot \vec{s} = (4 \hat{i} - 4 \hat{j}) \cdot (-2 \hat{i}) = -8 \text{ unit}$

(b) → (q, s)

(c) $\vec{F} = -4 \hat{i}$

∴ $W = \vec{F} \cdot \vec{s} = 8 \hat{i} \cdot (-2 \hat{i}) = -16 \text{ unit}$

and $|W| = 16 \text{ unit}$

(c) → (p, s)

(d) $\vec{F} = -4 \hat{i} - 4 \hat{j}$

∴ $W = \vec{F} \cdot \vec{s} = (-4 \hat{i} - 4 \hat{j}) \cdot (-2 \hat{i}) = 8 \text{ unit}$

and $|W| = 8 \text{ unit}$

Work done by Normal force (N) on block A

$$W = Ns \cos \theta$$

In motion 2 → +ve as $\theta < 90^\circ$

In motion 1 → +ve as $\theta < 90^\circ$

∴ Correct option is (b).

Work done by force of friction (f)

In motion 1 → may be -ive if f is directed upwards along the plane as shown in figure 1. (Motion 1 being retarded)

∴ Correct option is (c).

In motion 1 → may be +ive if f is directed downwards along the plane if motion 1 is accelerated.

∴ Correct option is (d).

(d) → (p, s).

2. $W = Fs \cos \theta$

(a) Work done by N will be +ive as $\theta < 90^\circ$

(a) → (p)

(b) Work done by mg will be -ive as $\theta = \pi$

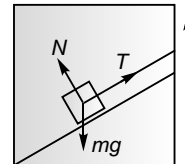

(b) → (q)

(c) Work done by force of friction (f) will be zero as f will be zero.

(c) → (r)

(d) Work done by tension (T) will be +ive as $\theta < 90^\circ$

(d) → (p)

- 3.

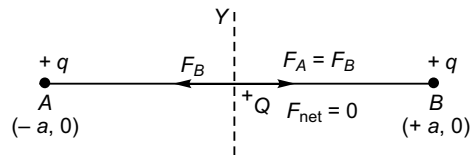

F_A = force on + Q by + q placed at A

F_B = force on + Q by + q placed at B

As $F_A = F_B$ charge $+Q$ will be in equilibrium.

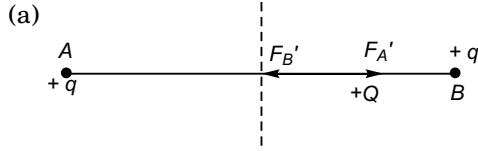

Due to increase in distance between $+q$ (at A) and $+Q$

$$F_{A'} < F_A$$

Due to decrease in distance between $+q$ (at B) and $+Q$

$$F_{B'} > F_B$$

Using $F_A = F_B$, we have $F_{B'} > F_{A'}$. As there will net force on $+Q$ which will bring $+Q$ to origin.

Thus, equilibrium will be a stable one.

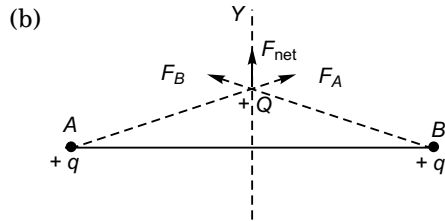

As F_{net} will be along the increasing direction of Y, the charge $+Q$ will not return to origin.

Thus, equilibrium will be an unstable one.

\therefore (b) \rightarrow (q)

(c) As explained in (b) the equilibrium will be an unstable on.

\therefore (c) \rightarrow (q)

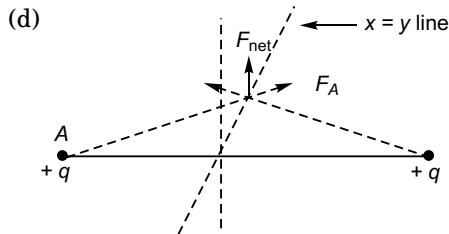

4. (a) From A to B :

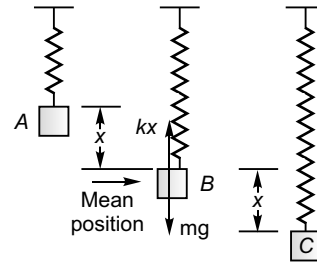

Increase in spring PE = $\frac{1}{2} kx^2$

Decrease in gravitational PE of block

$$= mgx$$

$$= (kx)x = kx^2$$

\therefore (a) \rightarrow (q)

(b) From A to B

Increase in KE of block

= Decrease in gravitational PE of block

– Increase in spring PE

$$= kx^2 - \frac{1}{2} kx^2$$

= $\frac{1}{2} kx^2 <$ Decrease in gravitational PE of block.

\therefore (b) \rightarrow (p)

(c) From B to C

Increase in spring PE = $\frac{1}{2} k(2x)^2 - \frac{1}{2} kx^2$

$$= \frac{3}{2} kx^2$$

Decrease in KE of block = $\frac{1}{2} kx^2$

(KE of block at C will be zero)

\therefore (c) \rightarrow (p).

(d) From B to C

decrease in gravitational PE = mgx

$$= (kx)x$$

$$= kx^2$$

Increase in spring PE = $\frac{3}{2} kx^2$

\therefore (d) \rightarrow (p)

$$5. a = \frac{m_1 - m_2}{m_1 + m_2} g = \frac{2 - 1}{2 + 1} g$$

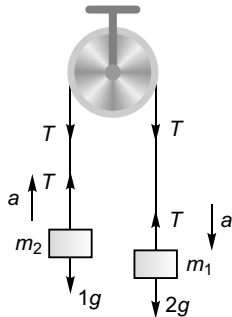

$$\begin{aligned} &= \frac{1}{3} g \\ &= \frac{10}{3} \text{ m s}^{-2} \\ T &= \frac{2m_1m_2}{m_1 + m_2} g \\ &= 2 \times \frac{1 \times 2}{1 + 2} \times 10 \\ &= \frac{40}{3} \text{ N} \end{aligned}$$

Displacement of blocks,

$$\begin{aligned} s &= ut + \frac{1}{2} at^2 \\ &= \frac{1}{2} at^2 \\ &= \frac{1}{2} \times \frac{10}{3} \times (0.3)^2 \\ &= 0.15 \text{ m} \end{aligned}$$

(a) Work done by gravity on 2 kg block

$$\begin{aligned} &= mgs \cos 0 \\ &= 2 \times 10 \times 0.15 \times (1) \\ &= 3 \text{ J} \end{aligned}$$

\therefore (a) \rightarrow (r)

(b) Work done by gravity on 1 kg block

$$\begin{aligned} &= mgs \cos \pi \\ &= 1 \times 10 \times 0.15 \times (-1) \\ &= -1.5 \text{ J} \end{aligned}$$

\therefore (b) \rightarrow (p).

(c) Work done by string on 2 kg block

$$\begin{aligned} &= Ts \cos \pi \\ &= \frac{40}{3} \times 0.15 \times (-1) \\ &= -20 \text{ J} \end{aligned}$$

\therefore (c) \rightarrow (s).

(d) Work done by string on 1 kg block

$$\begin{aligned} &= Ts \cos 0 \\ &= \frac{40}{3} \times 0.15 \times 1 \\ &= 2 \text{ J} \end{aligned}$$

\therefore (d) \rightarrow (q).

6. (a) Work done by friction force (f)
(w.r.t. ground)

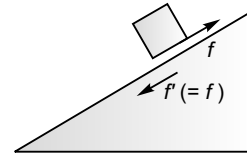

$$\begin{aligned} &= f s \cos \pi \\ &= -f s \end{aligned}$$

\therefore (a) \rightarrow (q).

(b) Work done by friction force on incline
(w.r.t. ground)

$$\begin{aligned} &= f \times 0 \times \cos 0 \\ &= 0 \end{aligned}$$

[There being no displacement of incline w.r.t. ground]

\therefore (b) \rightarrow (r).

(c) Work done by a man in lifting a bucket

$$\begin{aligned} &= Ts \cos 0 \quad (T = \text{Tension in rope}) \\ &= a + \text{ive quantity} \end{aligned}$$

$\theta = 0$ as T and s both would be in upward direction.

\therefore (c) \rightarrow (p).

(d) Total work done by friction force in (a)
w.r.t. ground

$$= -f s + 0 = -f s$$

\therefore (d) \rightarrow (q).

7

Circular Motion

Introductory Exercise 7.1

1. In uniform circular motion the magnitude of acceleration $\left(= \frac{v^2}{r}\right)$ does not change while its direction (being always towards the centre of the circular path) changes.
2. If ω_0 and ω are in rad s^{-1} the value of α must be in rad s^{-2} . But, if ω_0 and ω are in degree s^{-1} the value of α must also be in degree s^{-2} . Thus, it is not necessary to express all angles in radian. One way change rad into degree using $\pi \text{ rad} = 180^\circ$.
3. During motion of an object along a curved path the speed and magnitude of its radial acceleration may remain constant. Due to change in direction of motion the velocity of the object will change even if its speed is constant. Further, the acceleration will also change even if the speed is constant.

4. (i) Radial acceleration (a_c)

$$\begin{aligned}
 &= \frac{v^2}{r} = \frac{(2 \text{ cms}^{-1})^2}{1 \text{ cm}} \\
 &= 4 \text{ cms}^{-2}
 \end{aligned}$$

- (ii) Tangential acceleration (a_T)

$$\begin{aligned}
 &= \frac{dv}{dt} = \frac{d}{dt}(2t) \\
 &= 2 \text{ cms}^{-2}
 \end{aligned}$$

- (iii) Magnitude of net acceleration

$$\begin{aligned}
 &= \sqrt{(a_c)^2 + (a_T)^2} \\
 &= \sqrt{(4 \text{ cms}^{-2})^2 + (2 \text{ cms}^{-2})^2} \\
 &= 2\sqrt{5} \text{ cms}^{-2}
 \end{aligned}$$

5. $|\vec{v}_1| = |\vec{v}_2| = v$ (say)

$$T = \frac{2\pi r}{v}$$

$$\begin{aligned}
 |\vec{v}_{av}| &= \frac{|\vec{PQ}|}{t_{PQ}} \\
 &= \frac{r\sqrt{2}}{T/4} = \frac{r\sqrt{2}}{\pi r/2v} \\
 &= \frac{2\sqrt{2}}{\pi} v
 \end{aligned}$$

$$\therefore \frac{|\vec{v}_{av}|}{v} = \frac{2\sqrt{2}}{\pi}$$

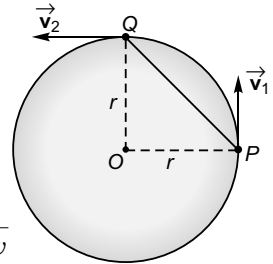

6. $\omega_t = 0 + 4t$

Centripetal acceleration

= tangential acceleration

$$r\omega_t^2 = r\alpha$$

$$\begin{aligned}
 \Rightarrow \quad &\omega_t^2 = \alpha \\
 &(4t)^2 = 4 \\
 &t = \frac{1}{2} \text{ s}
 \end{aligned}$$

Introductory Exercise 7.2

1. In uniform circular motion of a body the body is never in equilibrium as only one force (centripetal) acts on the body which forces the perform circular motion.

2. $v_{\max} = \sqrt{\frac{gra}{h}} = \sqrt{\frac{9.8 \times 250 \times (1.5/2)}{1.5}}$
 $= 35 \text{ ms}^{-1}$

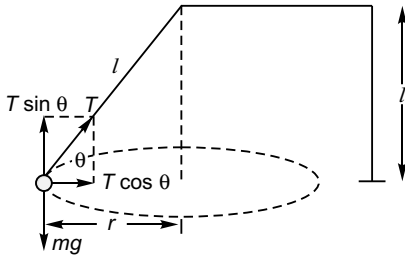

3. (a) $T \sin \theta = mg$

$T \cos \theta = mr\omega^2$

$\therefore \tan \theta = \frac{g}{r\omega^2}$

$\Rightarrow \omega = \sqrt{\frac{g}{r \tan \theta}} = \sqrt{\frac{g}{(l \cos \theta) \tan \theta}}$

or $\frac{2\pi}{T} = \sqrt{\frac{g}{l \sin \theta}} \Rightarrow T = 2\pi \sqrt{\frac{l \sin \theta}{g}}$

$= 2\pi \sqrt{\frac{\sqrt{2} \left(\frac{1}{\sqrt{2}}\right)}{9.8}}$

$\therefore f = \frac{1}{T} = \frac{\sqrt{9.8}}{2\pi} \text{ rve s}^{-1}$

$= \frac{\sqrt{9.8}}{2\pi} \times 60 \text{ rev min}^{-1}$

$= 29.9 \text{ rev min}^{-1}$

(b) $T = \frac{mg}{\sin \theta} = \sqrt{2} mg$

$= \sqrt{2} \times 5 \times 9.8 = 69.3 \text{ N}$

4.

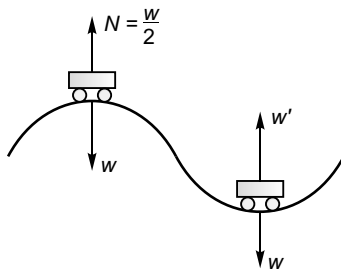

(a) At rest :

Required CPF = $w - N = \frac{w}{2}$

$\Rightarrow \frac{mv^2}{r} = \frac{w}{2} \dots(i)$

At dip :

Required CPF = $N' - w$

$\frac{mv^2}{r} = N' - w \dots(ii)$

Comparing Eqs. (i) and (ii),

$N' - w = \frac{w}{2}$

$\therefore N' = \frac{3w}{2} = \frac{3}{2} \times 16 \text{ kN}$

$= 24 \text{ kN}$

(b) At crest on increasing the speed (v), the value of N will decrease and for maximum value of v the of N will be just zero.

Thus, $\frac{mv_{\max}^2}{r} = w - 0$

$\Rightarrow v_{\max} = \sqrt{\frac{wr}{m}} = \sqrt{gr}$ (as $w = mg$)

$= \sqrt{10 \times 250}$
 $= 50 \text{ ms}^{-1}$

(c) At dip :

$N' = w + \frac{mv^2}{r}$

$= w + mg$

$= 2w = 32 \text{ kN}$

5. Case I. If the driver turns the vehicle

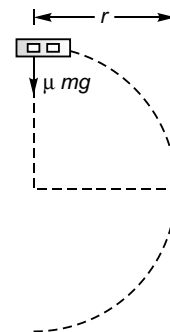

$$\frac{m v_1^2}{r} \leq \mu mg$$

[where v_1 = maximum speed of vehicle]

$$\Rightarrow v_1 \leq \sqrt{\mu gr}$$

Case II. If the driver tries to stop the vehicle by applying breaks.

Maximum retardation = μg

$$\therefore v_2^2 = 0^2 + 2(\mu g)r$$

$$\Rightarrow v_2 = \sqrt{2\mu gr} = \sqrt{2} v_1$$

As $v_2 > v_1$, driver should apply breaks to stop the vehicle rather than taking turn.

6. In the answer to question 3(a) if we replace θ by ϕ

$$\omega = \sqrt{\frac{g}{l \sin \phi}}$$

If θ is the angle made by the string with the vertical

$$\theta + \phi = 90^\circ$$

i.e., $\phi = 90^\circ - \theta$

$$\Rightarrow \sin \phi = \cos \theta$$

$$\therefore \omega = \sqrt{\frac{g}{l \cos \theta}}$$

$$\Rightarrow \cos \theta = \frac{g}{l \omega^2}$$

Introductory Exercise 7.3

1. $|\vec{v}_1| = u$ and $|\vec{v}_2| = v$ (say)

$$\Delta \vec{v} = \vec{v}_2 + (-\vec{v}_1)$$

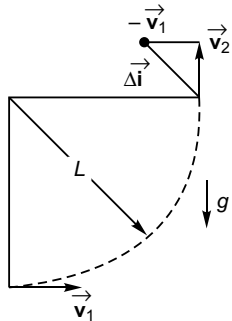

$$= \vec{v}_2 - \vec{v}_1$$

$$\Delta \vec{v} \cdot \Delta \vec{v} = (\vec{u}_2 - \vec{v}_1) \cdot (\vec{v}_2 - \vec{u}_1)$$

$$= \vec{u}_2 \cdot \vec{v}_2 + \vec{u}_1 \cdot \vec{v}_1 - 2\vec{v}_2 \cdot \vec{v}_1$$

$$|\vec{v}_2|^2 + |\vec{v}_1|^2 = v^2 + u^2$$

$$= u^2 - 2gL + u^2$$

$$|\Delta \vec{v}|^2 = 2(u^2 - gL)$$

$$|\Delta \vec{v}| = \sqrt{2(u^2 - gL)}$$

2. Ball motion from A to B :

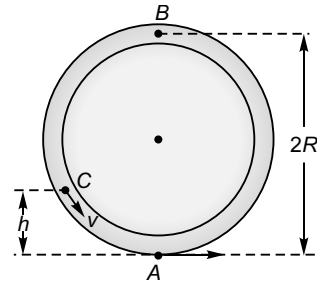

$$0^2 = u_{\min}^2 + 2(-g)(2R)$$

$$\Rightarrow u_{\min}^2 = 4gR$$

Ball motion from C to A :

$$v^2 = u_{\min}^2 + 2(-g)h$$

$$= 4gR - 2gh$$

$$\Rightarrow v = \sqrt{2g(2R - h)}$$

3. Decrease in KE of bob

= Increase in PE of bob

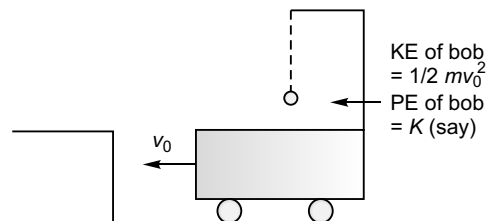

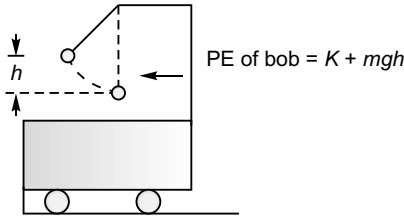

$$v_0^2 = 2gh$$

$$v_0 = \sqrt{2gl(1 - \cos \theta)}$$

$$= \sqrt{2 \times 9.8 \times 5 \times (1 - \cos 60^\circ)}$$

$$= 7 \text{ ms}^{-1}$$

$$\frac{1}{2}mv_0^2 = mgh$$

AIEEE Corner

Subjective Questions (Level 1)

1. $v = 4t^2$
- $\therefore \frac{dv}{dt} = 8t$
- i.e., $a_T = 8 \times 3 = 24 \text{ ms}^{-2}$
- $v = 4 \times 3^2 = 36 \text{ ms}^{-1}$ (at $t = 3 \text{ s}$)
- $\therefore a_c = \frac{v^2}{4} = \frac{(36)^2}{54} = 24 \text{ ms}^{-2}$

Angle between \vec{a}_{net} and \vec{a}_t

$$\theta = \tan^{-1} \frac{|\vec{a}_c|}{|\vec{a}_T|} = \tan^{-1} 1 = 45^\circ$$

2. $v = 16 \text{ ms}^{-1}$ and $r = 50 \text{ m}$
- $\therefore a_c = \frac{v^2}{r} = \frac{(16)^2}{50} = 5.12 \text{ ms}^{-2}$
- $a_{\text{net}} = \sqrt{a_c^2 + a_T^2} = \sqrt{(5.12)^2 + 8^2}$
- (given $a_T = 8 \text{ ms}^{-2}$)
- $= 9.5 \text{ ms}^{-2}$

3. Speed (v) at the highest point (P)

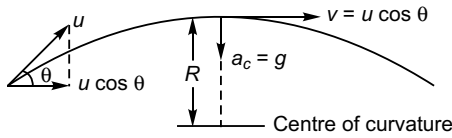

$v = u \cos \theta$

Now, $a_c = g$

$\therefore \frac{v^2}{R} = g$

i.e., $R = \frac{v^2}{g} = \frac{u^2 \cos^2 \theta}{g}$

4. (a) $a_c = a \cos 30^\circ = 25 \times \frac{\sqrt{3}}{2}$
- $= 21.65 \text{ ms}^{-2}$

- $\therefore \frac{v^2}{R} = 21.65$
- i.e., $v = \sqrt{21.65 \times 2.5}$ ($\because R = 2.5 \text{ m}$)
- $= 7.36 \text{ ms}^{-1}$
- (b) $a_T = a \sin 30^\circ = 25 \times \frac{1}{2} = 12.5 \text{ ms}^{-2}$

5. (a) $v = 2.0t = 2.0 \times 1$
- $= 2.0 \text{ cms}^{-1}$
- $\therefore a_c = \frac{v^2}{R} = \frac{(2.0)^2}{1} = 4 \text{ cms}^{-2}$

- (b) $v = 2.0t$
- $\therefore \frac{dv}{dt} = 2.0$
- i.e., $a_T = 2.0 \text{ cms}^{-2}$

- (c) $a_{\text{net}} = \sqrt{a_C^2 + a_T^2}$
- $= 4.47 \text{ cms}^{-2}$

6. $R = uT = u \sqrt{\frac{2h}{g}}$

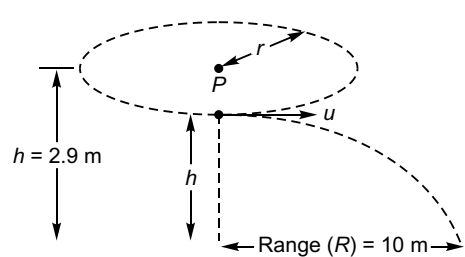

$\therefore u = R \sqrt{\frac{g}{2h}}$

i.e., $u^2 = \frac{R^2 g}{2h}$

Thus, centripetal acceleration of the stone (at point P) while in circular motion

$$= \frac{u^2}{r} = \frac{R^2 g}{2h} \cdot \frac{1}{r}$$

$$= \frac{10^2 \times 9.8}{2 \times 2.9 \times 1.5}$$

$$= 112.6 \text{ ms}^{-2}$$

7. $v = 18 \text{ km/h} = \frac{18.5}{18} \text{ ms}^{-1} = 5 \text{ ms}^{-1}$

Angle of banking (θ) = $\tan^{-1} \frac{v^2}{rg}$

$$= \tan^{-1} \frac{(5)^2}{10 \times 10}$$

$$= \tan^{-1} \frac{1}{40}$$

8. $\frac{mv^2}{r} = \mu mg$

i.e., $\mu = \frac{v^2}{gr} = \frac{(5)^2}{10 \times 10} = \frac{1}{4} = 0.25$

9. $v = \sqrt{rg \tan \theta}$

$$= \sqrt{50 \times 10 \times \tan 30^\circ}$$

$$= 17 \text{ ms}^{-1}$$

10. $mr\omega_{\min}^2 = N \dots(i)$

and $mg = \mu N \dots(ii)$

Solving Eqs. (i) and (ii),

$$\omega_{\min} = \sqrt{\frac{g}{\mu r}}$$

$$= \sqrt{\frac{10}{0.15 \times 3}}$$

$$= 4.7 \text{ rads}^{-1}$$

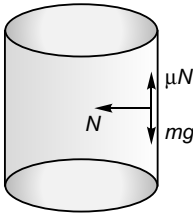

11. (a) $(T_1 + T_2) \cos \theta = mr\omega^2 \dots(i)$

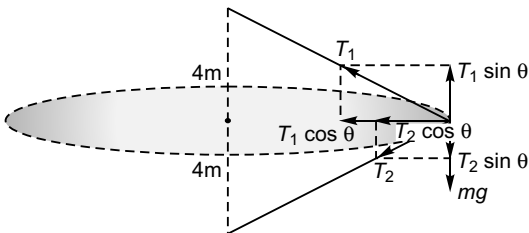

and $(T_1 - T_2) \sin \theta = mg \dots(ii)$

i.e., $T_2 \cos \theta = mr\omega^2 - T_1 \cos \theta$

and $T_2 \sin \theta = T_1 \sin \theta - mg$

$$\Rightarrow \cos \theta = \frac{mr\omega^2 - T_1 \cos \theta}{T_1 \sin \theta - mg}$$

or $T_1 \cos \theta - mg \cos \theta = mr\omega^2 - T_1 \cos \theta$

or $\omega = \sqrt{\frac{2T_1 \cos \theta - mg \cos \theta}{mr}}$

$$= \sqrt{\frac{2 \times 200 \times \left(\frac{3}{5}\right) - 4 \times 10 \times \left(\frac{3}{4}\right)}{4 \times 3}}$$

$$= 8.37 \text{ rads}^{-1}$$

$$8.37 \times \frac{1}{2\pi} \text{ rev}$$

$$= \frac{1}{60} \text{ min}$$

$$= 39.94 \text{ rev min}^{-1}$$

(b) From Eq. (ii),

$$T_2 = T_1 - \frac{mg}{\sin \theta}$$

$$= 200 - \frac{4 \times 100}{\left(\frac{4}{5}\right)}$$

$$= 150 \text{ N}$$

12. (a) For the block not to slip

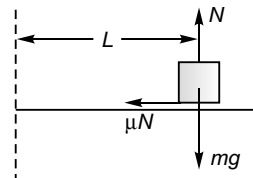

$$mL\omega_{\max}^2 = \mu N = \mu mg$$

$\therefore \omega_{\max} = \sqrt{\frac{\mu g}{L}}$

(b) If the angular speed is gradually increased, the block will also have translational acceleration ($= \alpha L$) besides centripetal acceleration ($= L\omega^2$).

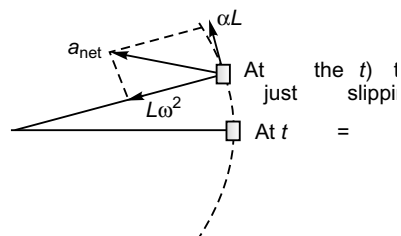

The block will be at the point of slipping, when

$$ma_{\text{net}} = \mu mg$$

$$\text{i.e., } \sqrt{(L\omega^2)^2 + (\alpha L)^2} = \mu g$$

$$\text{or } L^2\omega^4 + \alpha^2 L^2 = \mu^2 g^2$$

$$\text{or } \omega^4 + \alpha^2 = \frac{\mu^2 g^2}{L^2}$$

$$\text{or } \omega = \left[\frac{\mu^2 g^2}{L^2} - \alpha^2 \right]^{\frac{1}{4}}$$

13. $F' = 2F \cos \frac{60^\circ}{2} = F\sqrt{3}$

$$PQ = QR = RP = a = 2PO \cos 30^\circ$$

$$\therefore a = r\sqrt{3}$$

For the circular motion of P, Q or R

$$\frac{mv^2}{r} = F' = F\sqrt{3}$$

$$\text{or } \frac{mv^2}{r} = \frac{Gmm}{(r\sqrt{3})^2} - \sqrt{3}$$

$$\text{or } v = \left[\frac{Gm}{r\sqrt{3}} \right]^{\frac{1}{2}} = \left[\frac{GM}{a} \right]^{\frac{1}{2}}$$

Now, $v = \frac{2\pi r}{T}$

$$\therefore T = \frac{2\pi r}{v} = 2\pi \frac{a/\sqrt{3}}{\left[\frac{GM}{a} \right]^{\frac{1}{2}}} = 2\pi \sqrt{\frac{a^3}{3GM}}$$

14. $N \sin \theta = mr\omega^2$

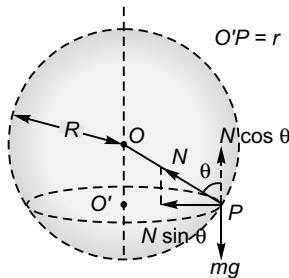

and $N \cos \theta = mg$

$$\therefore \frac{\sin \theta}{\cos \theta} = \frac{r\omega^2}{g} \text{ or } \frac{\sin \theta}{\cos \theta} = \frac{(R \sin \theta) \omega^2}{g}$$

$$\text{i.e., } \cos \theta = \frac{g}{R\omega^2}$$

For $\theta > 0^\circ$: $\cos \theta < 1$

$$\text{i.e., } \frac{g}{R\omega^2} < 1 \text{ or } \omega > \sqrt{\frac{g}{R}}$$

$$\therefore \text{if } \omega \leq \sqrt{\frac{g}{R}} : \theta = 0^\circ$$

i.e., bead will remain at the lowermost position.

$$\text{For } \omega = \sqrt{\frac{2g}{R}} : \cos \theta = \frac{g}{R \left(\frac{2g}{R} \right)} = \frac{1}{2}$$

$$\text{i.e., } \theta = 60^\circ$$

15. (a) $T = 2 \cdot 2 \cdot \omega^2$

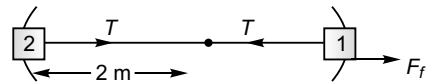

$$= 4(4)^2$$

$$= 64 \text{ N}$$

$$T - F_f = 1 \cdot 1 \cdot \omega^2$$

$$64 - F_f = (4)^2$$

$$\Rightarrow F_f = 48 \text{ N}$$

(b) $T = 2 \cdot 2 \cdot \omega_{\text{max}}^2$ and

$$T - F_{f_{\text{max}}} = 1 \cdot 1 \cdot \omega_{\text{max}}^2$$

$$\therefore 4\omega_{\text{max}}^2 - F_{f_{\text{max}}} = 1 \cdot \omega_{\text{max}}^2$$

$$\text{i.e., } 3\omega_{\text{max}}^2 = \mu mg$$

$$\therefore \omega_{\text{max}} = \sqrt{\frac{\mu mg}{3}}$$

$$= \sqrt{\frac{0.8 \times 1 \times 10}{3}}$$

$$= 1.63 \text{ rad s}^{-1}$$

(c) $100 = 2 \cdot 2 \cdot \omega_{\text{max}}^2$

$$\therefore \omega_{\text{max}} = 5 \text{ rad s}^{-1}$$

Therefore, if the string can sustain a tension of 1100 N, the angular speed of the block system will be 5 rad s^{-1} .

In this case the frictional force (F_f) on the block of mass 1 kg will be given by the relation

$$100 - F_f = 1 \cdot 1 \cdot 5^2$$

$$\Rightarrow F_f = 75 \text{ N}$$

16. $v_{\text{max}} = \sqrt{\frac{grl}{h}}$

$$= \sqrt{\frac{10 \times 200 \times 0.75}{1.5}} \quad (2r = 1.5 \text{ m})$$

$$= 31.6 \text{ ms}^{-1}$$

17. If the block just leaves the surface of sphere at point C

$$\frac{mv^2}{r} = mg \cos \theta \quad \dots(i)$$

[v = velocity of block at point C]

$$\Rightarrow v^2 = gr \cos \theta$$

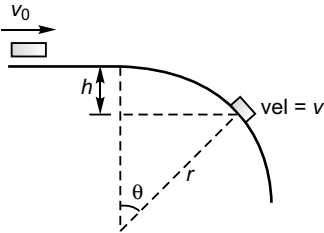

Further, $v^2 = v_0^2 + 2gh$
 $= v_0^2 + 2gr(1 - \cos \theta) \quad \dots(ii)$

Comparing Eqs. (i) and (ii),

$$v_0^2 + 2gr(1 - \cos \theta) = gr \cos \theta$$

or $(0.5\sqrt{gr})^2 + 2gr(1 - \cos \theta) = gr \cos \theta$
 $\frac{1}{4} + 2(1 - \cos \theta) = \cos \theta$

i.e., $\theta = \cos^{-1}\left(\frac{3}{4}\right)$

18. $T - mg \cos \theta = \frac{mv^2}{r}$

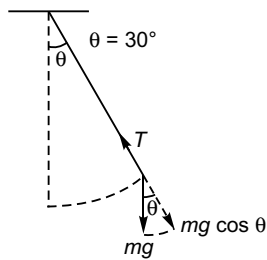

$$\therefore 2.5mg - mg \cos \theta = \frac{mv^2}{r}$$

$$\therefore a_c = \frac{v^2}{r} = 25 - 5\sqrt{3} \text{ ms}^{-2}$$

$$a_t = g \sin \theta = 5 \text{ ms}^{-2}$$

Thus, $a_{\text{net}} = \sqrt{(a_c)^2 + (a_t)^2}$
 $= \sqrt{(25 - 5\sqrt{3})^2 + (5)^2}$
 $= \sqrt{625 + 75 + 25 - 10\sqrt{3}}$
 $= 26.60 \text{ m/s}^2$

19. At point P

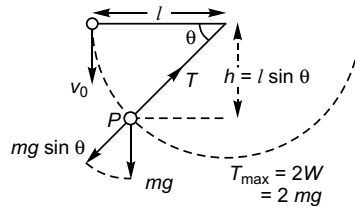

$$T - mg \sin \theta = \frac{mv^2}{l}$$

$$= \frac{m}{l} [v_0^2 + 2gh]$$

or $2mg - mg \sin \theta = \frac{m}{l} [v_0^2 + 2gl \sin \theta]$

or $2g - g \sin \theta = \frac{5^2 + 2g \times 2 \sin \theta}{2}$

Solving, $\sin \theta = \frac{1}{4}$

i.e., $\theta = \sin^{-1}\left(\frac{1}{4}\right)$

20. $8 = 5 + 5 \cos \theta$

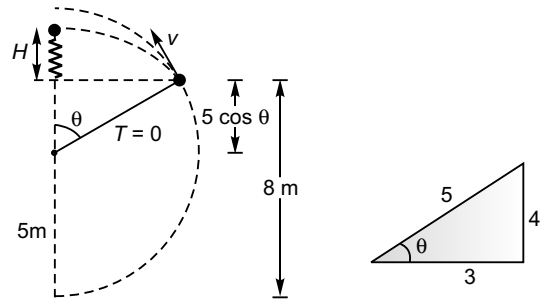

$$\therefore \cos \theta = \frac{3}{5}$$

$$T + mg \cos \theta = \frac{mv^2}{r}$$

$$\Delta t \theta = \cos^{-1} \frac{3}{5}$$

T is just zero.

$$\therefore mg \cos \theta = \frac{mv^2}{r}$$

i.e., $v^2 = 5g \cos \theta$
 $= 30$

$$\therefore v = 5.42 \text{ ms}^{-1}$$

The height (H) to which the particle will rise further.

$$H = \frac{v^2 \sin^2 \theta}{2g} = \frac{30}{2 \times 10} \times \frac{16}{25}$$

$$= \frac{24}{25} = 0.96 \text{ m}$$

21. (a) $N = \frac{mv^2}{R} = m \frac{8gR}{R} = 8mg$

$$v^2 = 0^2 + 2g \cdot 4R$$

$$= 8gR$$

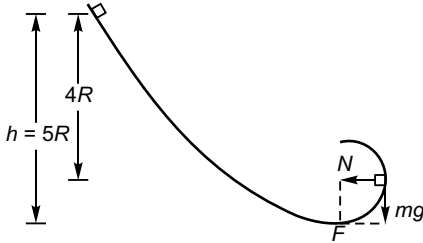

$$\therefore F = \sqrt{N^2 + (mg)^2}$$

$$= \sqrt{64 m^2 g^2 + m^2 g^2}$$

$$= \sqrt{65} mg$$

(b) $N' + mg = \frac{mv'^2}{R}$

$$mg + mg = \frac{m}{R} 2g (h' - 2R)$$

or $2R = 2(h' - 2R)$

i.e., $h' = 3R$

Objective Questions (Level 1)

Single Correct Option

1. (a) As the speed (v) is increasing uniformly the magnitude of centripetal acceleration ($= \frac{v^2}{r}$) will also keep on increasing besides

its direction as usual.

(b) $v = kt$ ($k = \text{constant}$)

$$\therefore \frac{dv}{dt} = k$$

i.e., $a_t = k$

Although the magnitude of the tangential acceleration will remain constant but its direction will keep on changing as the direction of velocity would be changing.

(c) $v = kt$

$$R\omega = kt$$

$$\omega = k' t$$

$$(k' = \frac{k}{R} = \text{constant})$$

$$\frac{d\omega}{dt} = k'$$

$$\alpha = \text{constant.}$$

As the direction of α (angular acceleration) is perpendicular to the plane of rotation of the body, it will remain constant both in magnitude and direction.

Option (c) is correct.

2. $|\vec{p}_1| = |\vec{p}_2| = mv$

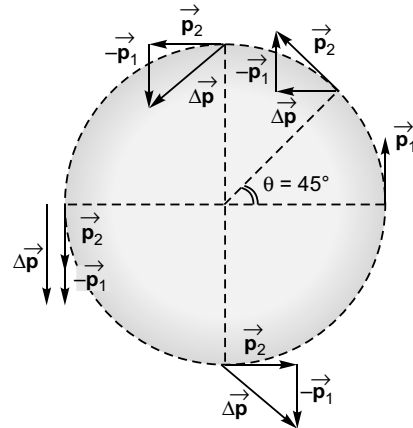

$$\theta = 45^\circ, |\Delta \vec{p}| = 2mv \sin 22 \frac{1}{2}^\circ$$

$$= 0.765 mv$$

$$\theta = 90^\circ, |\Delta \vec{p}| = 2mv \sin 45^\circ$$

$$= 1.414 mv$$

$$\theta = 180^\circ, |\Delta \vec{p}| = 2mv \sin 90^\circ$$

$$= 2mv$$

(max)

$$\theta = 270^\circ, |\Delta \vec{p}| = 2mv \sin 135^\circ$$

$$= 1.414 mv$$

$$\theta = 360^\circ, |\Delta \vec{p}| = 2mv \sin 180^\circ = 0 \text{ (min)}$$

Option (c) is correct.

3.

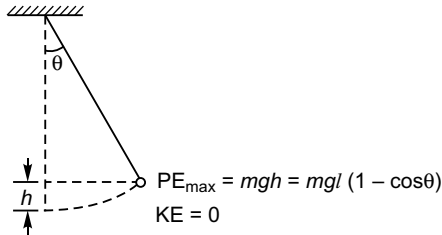

$$\therefore KE_{\max} = mgl(1 - \cos \theta) \quad [\text{as here PE} = 0]$$

Option (c) is correct.

4.

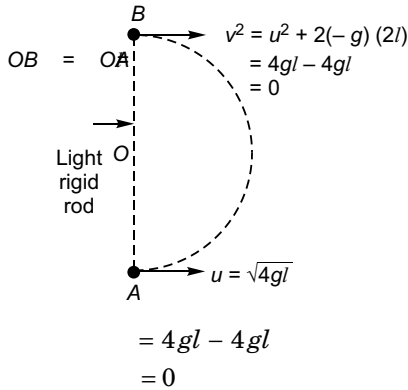

If the mass m is given velocity $u (= \sqrt{4gl})$ at point A it will complete circle to reach point B (the highest point) with zero velocity.

[If in place of light rod these is light string the minimum value of u at A for the mass to reach point B will be $\sqrt{5gl}$ and the minimum velocity at B will be \sqrt{gl} .]

5. As explained in question 4 speed at lowest point

$$u = \sqrt{5gl}$$

At the lowest point

$$T - mg = \frac{mu^2}{l} = \frac{m5gl}{l} = 5mg$$

$$\Rightarrow T = 6mg$$

Option (d) is correct.

6. Normal acceleration

= Tangential acceleration

$$\frac{v^2}{R} = 5 \text{ (cms}^{-2}\text{)}$$

$$\therefore v = 10 \text{ cms}^{-1} \quad (\because R = 20 \text{ cm})$$

$$\text{Using, } v = 0 + 5t$$

$$10 = 5t$$

$$\Rightarrow t = 2 \text{ s}$$

Option (b) is correct.

7. Mass = 2π kg

$$\therefore \text{Mass per unit length} = \frac{2\pi \text{ kg}}{2\pi (0.25) \text{ m}}$$

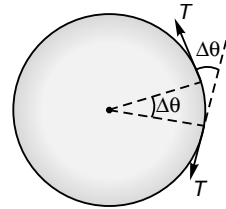

$$\Delta m = \frac{1}{0.25} r \Delta \theta = \Delta \theta \quad (\because r = 0.25)$$

$$= \frac{1}{0.25} \text{ kgm}^{-1}$$

$$\omega = 300 \frac{\text{rev}}{\text{min}}$$

$$= 300 \times \frac{2\pi \text{ rad}}{60 \text{ s}}$$

$$= 10\pi \text{ rad s}^{-1}$$

From figure

$$2T \cos \left(\frac{180^\circ - \Delta \theta}{2} \right) = (\Delta m) r \omega^2$$

$$\text{or } 2T \sin \frac{\Delta \theta}{2} = (\Delta m) r \omega^2$$

$$\text{or } 2T \frac{\Delta \theta}{2} = (\Delta m) r \omega^2$$

$$\text{or } T \Delta \theta = (\Delta \theta) r \omega^2$$

$$\text{or } T = r \omega^2 = 0.25 \times (10\pi)^2 \approx 250 \text{ N} \quad (\because \pi^2 \approx 10)$$

Option (d) is correct.

8. Maximum speed of car = $\sqrt{\mu gr}$

$$= \sqrt{0.3 \times 10 \times 300}$$

$$= 30 \text{ m/s}$$

$$= 30 \times \frac{18}{5} \text{ km/h}$$

$$= 108 \text{ km/h}$$

Option (c) is correct.

9. $T \sin \theta = m r \omega^2 = m (l \sin \theta) \omega^2$

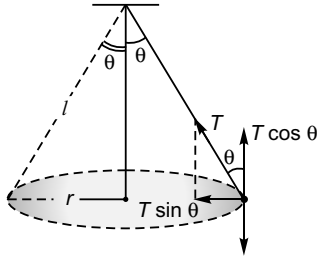

and $T \cos \theta = mg$

$$\therefore \cos \theta = \frac{g}{l \omega^2}$$

$$\omega l = \frac{2}{\pi} \text{ revs}^{-1}$$

$$= \frac{2}{\pi} (2\pi \text{ rad}) \text{ s}^{-1}$$

$$= 4 \text{ rads}^{-1}$$

$$\therefore \cos \theta = \frac{10}{1(4)^2} = \frac{5}{8}$$

i.e., $\theta = \cos^{-1}\left(\frac{5}{8}\right)$

Option (d) is correct.

10. From above question no. 9.

$$t = m l \omega^2$$

$$= \frac{100}{1000} \times 1 \times 4^2 = \frac{8}{5} \text{ N}$$

Option (b) is correct.

11. $\alpha = \frac{1}{3} \text{ rads}^{-1}$ and $R = 25 \text{ cm}$

$$\therefore a_t = R \alpha = \frac{25}{3} \text{ cms}^{-2}$$

Thus, $\omega_t = 0 + \alpha t$

$$= \frac{1}{3} \times 2 \quad [\because t = 2 \text{ s}]$$

$$\therefore a_N = R \omega_t^2 = 25 \times \left(\frac{2}{3}\right)^2 \text{ cms}^{-2}$$

Thus, $a_{\text{net}} = \sqrt{a_N^2 + a_t^2} = \sqrt{\frac{725}{3}} \text{ cms}^{-2}$

Frictional force $= m a_{\text{net}}$

$$= 0.36 \times 10^{-3} \text{ kg} \times \frac{\sqrt{725}}{3} \times 10^{-2} \text{ ms}^{-2}$$

$$= 32.4 \mu\text{N}$$

Option (a) is correct.

12. At the lowermost point

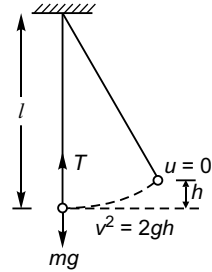

$$T - mg = \frac{m v^2}{l}$$

or $T = \frac{m \cdot 2gh}{l} + mg$

$$= mg \left(1 + \frac{2h}{l}\right)$$

Option (d) is correct.

13. $\omega_A = \frac{2\pi}{3} \text{ rad min}^{-1}$

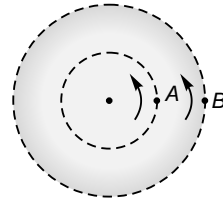

and $\omega_B = 2\pi \text{ rad min}^{-1}$

$$\therefore \omega_{BA} = \omega_B - \omega_A$$

$$= \left(2\pi - \frac{2\pi}{3}\right) \text{ rad min}^{-1}$$

$$= \frac{4\pi}{3} \text{ rad min}^{-1}$$

Time required for B to complete one revolution w.r.t. A

$$= \frac{2\pi}{4\pi/3} = \frac{3}{2} \text{ min}$$

$$= 1.5 \text{ min}$$

Option (c) is correct.

14. Let all the particles meet at time t (seconds)

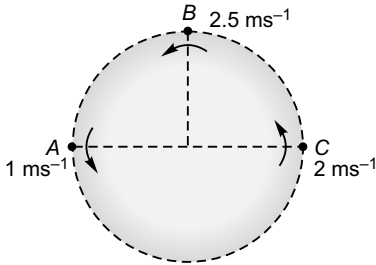

∴ Distance travelled by B in t second :

$$\begin{aligned} \text{Distance travelled by C in } t \text{ second} &= 2.5t : 2t \\ &= 5 : 4 \end{aligned}$$

Option (c) is correct.

JEE Corner

Assertion and Reason

1. For stopping car :

$$\begin{aligned} \text{Maximum retardation} &= \frac{\text{Maximum frictional force}}{m} \\ &= \frac{\mu N}{m} = \frac{\mu mg}{m} = \mu g \end{aligned}$$

$$v^2 = u^2 + 2as$$

$$0^2 = v^2 + (2)(-\mu g)d \quad [\because \text{Initial velocity} = v]$$

$$\therefore d = \frac{v^2}{2\mu g}$$

For circular turn of car :

Centripetal force

$$= \text{Maximum frictional force} = \mu mg$$

$$\therefore \frac{mv^2}{d'} = \mu mg$$

$$\text{i.e., safe radius} = d' = \frac{v^2}{\mu g} \Rightarrow d' = 2d$$

Thus, Assertion and Reason are both correct and Reason is the correct explanation of the Assertion.

Option (a) is correct.

2. $\vec{a}_{av} = \frac{\vec{v}_B - \vec{v}_A}{t_{AB}}$

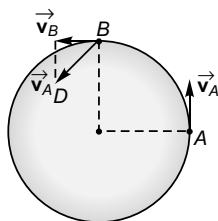

$$\text{i.e., } |\vec{a}_{av}| = \frac{|\vec{BD}|}{t_{AB}} = \frac{v\sqrt{2}}{t_{AB}}$$

$$\text{Now, } |\vec{v}_{av}| = \frac{|\vec{AB}|}{t_{AB}} = \frac{R\sqrt{2}}{t_{AB}}$$

$$\therefore \frac{|\vec{a}_{av}|}{|\vec{v}_{av}|} = \frac{v\sqrt{2}}{R\sqrt{2}} = \omega \text{ (angular velocity)}$$

Thus, assertion is correct.

In circular motion, when speed is constant, the angular velocity will obviously be constant; but this reason does not lead to the result as explained.

Option (b) is correct.

3. A frame moving in a circle with constant speed can never be an inertial frame as the frame is not moving with constant velocity (due to change in direction).

Reason that the frame is having constant acceleration is false.

Option (c) is correct.

4. If speed is constant angle between \vec{v} and \vec{a} will always be 90°

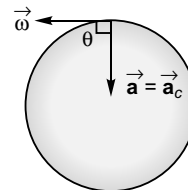

$$\therefore \vec{v} \cdot \vec{a} = 0$$

If speed is increasing angle θ between \vec{v} and \vec{a} will be less than 90° .

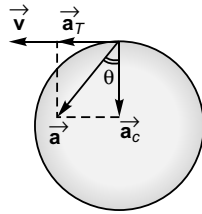

$\therefore \vec{v} \cdot \vec{a}$ will be positive.

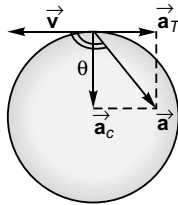

If speed is decreasing angle between \vec{v} and \vec{a} will be greater than 90° .

$\therefore \vec{v} \cdot \vec{a}$ will be negative.

Assertion is correct.

Reason $\vec{\omega} \cdot \vec{v} = 0$ as both are perpendicular to each other.

Reason is also true but not the correct explanation of the assertion.

Option (b) is correct.

5. $\vec{v} = 2\hat{i} \text{ ms}^{-1}$

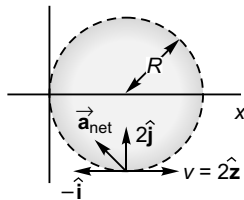

$$\vec{a} = -\hat{i} + 2\hat{j} \text{ ms}^{-2}$$

$\therefore \vec{a}_c = 2\hat{j} \text{ ms}^{-2}$

$$\vec{a}_c = |\vec{a}_c| = 2 \text{ ms}^{-2}$$

$$v = |\vec{v}| = 2 \text{ ms}^{-1}$$

$$a_c = \frac{v^2}{R}$$

$$\begin{aligned} \Rightarrow R &= \frac{v^2}{a_c} \\ &= \frac{(2)^2}{2} = 2 \text{ m} \\ \vec{a}_T &= -\hat{i} \text{ ms}^{-2} \end{aligned}$$

Speed is decreasing (as \vec{a}_T is -ive) at a rate of 1 ms^{-1} per second *i.e.*, 1 ms^{-2} .

Both Assertion and the Reason are correct but reason has nothing to do with the assertion.

Option (b) is correct.

6. $\vec{a} = \vec{a}_T + \vec{a}_c$ (Reason)

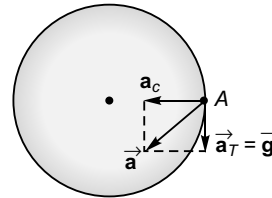

$\therefore |\vec{a}| = \sqrt{\frac{v^2}{r} + g^2}$

$\Rightarrow |\vec{a}| > g$ (Assertion)

We see that both Assertion and the Reason are correct and the reason is the correct explanation of assertion.

Option (a) is correct.

7. At points A and C : The bob is momentarily at rest.

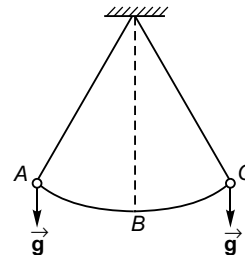

i.e., $v = 0$ (Reason)

$\therefore |\vec{a}_c| = \frac{v^2}{R} = 0$

but net acceleration is not zero (see figure) *i.e.*, Assertion is false.

\therefore Option (d) is correct.

8. v (speed) = $4t - 12$

For $t < 3$ (time unit) speed is negative, which can't describe a motion. Thus, assertion is correct.

As speed can be changed linearly with time, the reason is false.

Option (c) is correct.

9. In circular motion the acceleration changes regularly where as in projectile motion it is constant. Thus, in circular motion we can't apply $\vec{v} = \vec{u} + \vec{a} t$ directly, whereas in projectile motion we can say reason that in circular motion gravity has no role is wrong.

Option (c) is correct.

10. $N = mg \cos \theta$

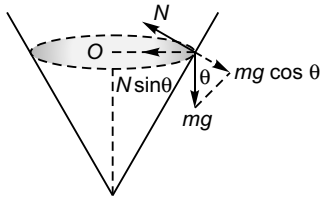

Therefore, assertion is wrong.

Particle performs circular motion due to $N \sin \theta$

$$\therefore \frac{mv^2}{r} = N \sin \theta$$

Objective Questions (Level 2)

Single Correct Option

1. $KE \left(\frac{1}{2} mv^2 \right) = \text{Change in PE} \left[\frac{1}{2} k(\Delta x)^2 \right]$

$$\Delta x = \text{Length of spring (Collar at B)} - \text{Length of spring (Collar at A)}$$

$$= \sqrt{(7+5)^2 + 5^2} \text{ m} - 7\text{m} = 6\text{ m}$$

$$\text{Thus, } \frac{1}{2} \times 2 \times v^2 = \frac{1}{2} \times 200 \times 6^2$$

i.e., $v^2 = 3600$

$$\therefore \text{Normal reaction} = \frac{mv^2}{r} = \frac{2 \times 3600}{5} = 1440\text{ N}$$

Option (a) is correct.

$N \cos \theta$ is balanced by mg (weight of particle).

Acceleration is not along the surface of the funnel. It is along the centre O of the circle. Thus, reason is true.

Option (d) is correct.

11. Centripetal force $\left(\frac{mv^2}{r} \right) = N + mg$

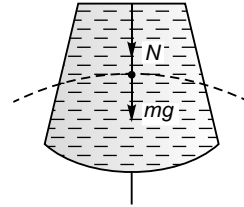

i.e., Centripetal force (reason) $\geq wt$ (mg) of water

for $N = 0, v = \sqrt{gr}$

If at the top of the circular path $v \geq \sqrt{gr}$

i.e., if bucket moved fast, the water will not fall (Assertion).

As assertion and reason both are true and reason is the correct explanation of the assertion of the option would be (a).

2. The particle will remain in equilibrium till ω is constant. Any change in the value of ω will displace the particle up (if ω increase) and down (if ω decreases). Thus, the equilibrium is unstable.

Option (b) is correct.

3. Centripetal force = μmg

or $mr\omega^2 = \mu mg$

or $\frac{5a}{4} \omega^2 = \mu g$

or $\omega^2 = \frac{4g}{15a}$ (as $\mu = \frac{1}{3}$)

Option (d) is correct.

4. Acceleration at $B =$ Acceleration at A

$$\therefore \frac{v^2}{r} = g \sin \theta$$

$$\text{or } \frac{2gr(1 - \cos \theta)}{r} = g \sin \theta$$

$$\text{or } 2(1 - \cos \theta) = \sin \theta$$

$$\text{or } [2(1 - \cos \theta)]^2 = 1 - \cos^2 \theta$$

$$\text{or } (5 \cos \theta - 3)(\cos \theta - 1) = 0$$

As $\cos \theta = 1$, i.e., $\theta = 0^\circ$ is not possible.

$$\cos \theta = \frac{3}{5}$$

$$\text{i.e., } \theta = \cos^{-1} \frac{3}{5}$$

Option (c) is correct.

5. At point P (for the circular motion)

$$mg \cos \theta - N = \frac{mv^2}{R}$$

If at point P skier leaves the hemisphere.

$$N = 0$$

$$\therefore mg \cos \theta = \frac{mv^2}{R}$$

$$\text{or } mg \cos \theta = \frac{m}{R} 2g \left(h + \frac{R}{4} \right)$$

$$\text{or } mg \cos \theta = \frac{m}{R} 2g \left[R(1 - \cos \theta) + \frac{R}{4} \right]$$

$$\Rightarrow \cos \theta = 2 \left[(1 - \cos \theta) + \frac{1}{4} \right]$$

$$\text{i.e., } \theta = \cos^{-1} \frac{5}{6}$$

Option (c) is correct.

6. Velocity at B

$$\begin{aligned} v &= \sqrt{2gh} \\ &= \sqrt{2gR(\cos \theta_2 - \cos \theta_1)} \\ &= \sqrt{2gR(\cos 37^\circ - \cos 53^\circ)} \\ &= \sqrt{2gR \left(\frac{4}{3} - \frac{3}{5} \right)} \\ &= \sqrt{\frac{2gR}{5}} \end{aligned}$$

For the circular motion at B , when block just leaves the track

$$\frac{v^2}{R_1} = g \cos \theta_2$$

$$\begin{aligned} \text{or } R_1 &= \frac{v^2}{g \cos \theta_2} = \frac{2R}{5 \cos \theta_2} \\ &= \frac{2R}{5 \cdot \cos 37^\circ} \\ &= \frac{2R}{5 \cdot \left(\frac{4}{5} \right)} \\ &= \frac{R}{2} \end{aligned}$$

Option (c) is correct.

$$\begin{aligned} 7. \quad mg \cos \theta &= \frac{mv^2}{a} \\ &= \frac{4^2 + 2 \cdot g \cdot \frac{a}{4}}{a} \\ \text{or } g \cos \theta &= \frac{4^2 + 2 \cdot g \cdot \frac{a}{4}}{a} \\ \text{or } g \frac{a - \frac{a}{4}}{4} &= \frac{u^2 + 2 \cdot g \cdot \frac{a}{4}}{a} \\ \text{or } g \cdot \frac{3}{4} a &= u^2 + 2g \frac{a}{4} \\ \Rightarrow u &= \frac{\sqrt{ag}}{2} \end{aligned}$$

Option (c) is correct.

$$\begin{aligned} 8. \quad \frac{v^2}{r} &= \frac{4}{r^2} \\ \Rightarrow v &= \frac{2}{\sqrt{r}} \\ \therefore \text{Momentum} &= mv \\ &= \frac{2m}{\sqrt{r}} \end{aligned}$$

9. $N \cos \theta = mr\omega^2$

and $N \sin \theta = mg$

$$\begin{aligned} \therefore N &= m\sqrt{g^2 + r^2\omega^4} \\ &= m\sqrt{g^2 + r^2 \left(\frac{2\pi}{T} \right)^4} \\ &= 10 \sqrt{10^2 + (0.5)^2 \left(\frac{2\pi}{1.5a} \right)^4} \\ &= 128 \text{ N} \end{aligned}$$

Option (b) is correct.

$$\begin{aligned} 10. \quad \theta &= \omega_0 t + \frac{1}{2} \alpha t^2 \\ &= \left[\omega_0 + \frac{1}{2} \alpha t \right] t \end{aligned}$$

$$\begin{aligned}
 &= \left[\frac{v}{R} + \frac{1}{2} \left(-\frac{1}{R} \cdot \frac{v^2}{4\pi R} \right) \left(\frac{4\pi R}{v} \right) \right] t \\
 &= \left[\frac{v}{R} - \frac{v}{2R} \right] \frac{4\pi R}{v} \\
 &= 4\pi \\
 &= 2 \text{ rev.} \\
 11. \quad H &= \frac{1}{2} g T^2
 \end{aligned}$$

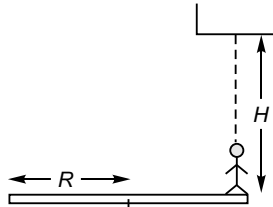

$$\begin{aligned}
 \Rightarrow T &= \sqrt{\frac{2H}{g}} \\
 \omega &= \frac{2\pi}{T} = 2\pi \sqrt{\frac{g}{2H}} \\
 &= \pi \sqrt{\frac{2g}{H}}
 \end{aligned}$$

$$\begin{aligned}
 12. \quad \omega \text{ (minute hand)} &= \frac{2\pi}{3600} \text{ rad s}^{-1} \\
 \omega \text{ (second hand)} &= \frac{2\pi}{60} \text{ rad s}^{-1}
 \end{aligned}$$

For second hand to meet minute hand for the first time.

$2\pi +$ Angle moved by minute hand in t second

$=$ Angle moved by second hand in t second

$$\begin{aligned}
 \text{or } 2\pi + \frac{2\pi}{3600} t &= \frac{2\pi}{60} t \\
 1 &= \frac{t}{60} - \frac{t}{3600} \\
 1 &= \frac{t}{60} \times \frac{59}{60} \\
 \Rightarrow t &= \frac{3600}{59} \text{ s}
 \end{aligned}$$

Option (d) is correct.

$$\begin{aligned}
 13. \quad (PR)^2 + (QR)^2 &= (PQ)^2 \\
 (v_A \cdot 2)^2 + (v_B \cdot 2)^2 &= 30^2 \\
 v_A^2 + v_B^2 &= 225 \quad \dots(i)
 \end{aligned}$$

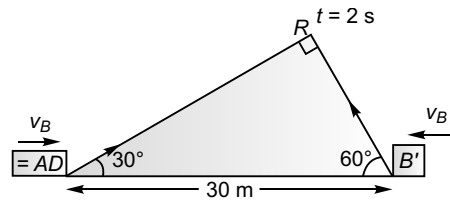

Further, $\frac{PR}{PQ} = \cos 30^\circ$

$$\frac{v_A \cdot 2}{30} = \frac{\sqrt{3}}{2}$$

$$\Rightarrow v_A = 7.5\sqrt{3} \text{ ms}^{-1}$$

Substituting value of v_A in Eq. (i),

$$v_B = 7.5 \text{ ms}^{-1}$$

$$14. \quad mg \cos \theta - N = \frac{mv^2}{r}$$

When breaks off $N = 0$

$$\therefore mg \cos \theta = \frac{mv^2}{r}$$

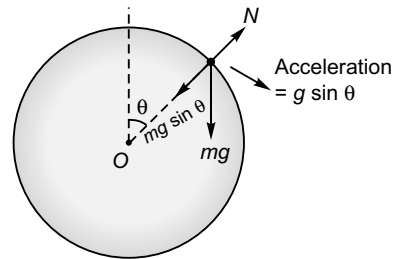

$$\text{or } g \cos \theta = \frac{2gr(1 - \cos \theta)}{r}$$

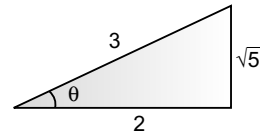

$$\text{or } \cos \theta = 2(1 - \cos \theta)$$

$$\text{or } \cos \theta = \frac{2}{3}$$

Acceleration of particle when it leaves sphere

$$\begin{aligned}
 &= g \sin \theta \\
 &= \frac{g\sqrt{5}}{3}
 \end{aligned}$$

Option (b) is correct.

15. For minimum velocity (v) :

$$\tan \theta = \tan 45^\circ = 1$$

$$\mu = 1 \quad \text{(given)}$$

As $\mu = \tan \theta$

θ is the angle of repose.

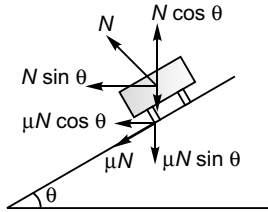

Therefore, the automobile will be at the point of slipping when its velocity is zero

For maximum velocity (v')

$$N \sin \theta + \mu N \cos \theta = \frac{mv'^2}{r}$$

Also $N \cos \theta = mg + \mu N \sin \theta$
i.e., $N(\cos \theta - \mu \sin \theta) = mg \quad \dots(ii)$

Dividing Eq. (i) by Eq. (ii),

$$\frac{\sin \theta + \mu \cos \theta}{\cos \theta - \mu \sin \theta} = \frac{v'^2}{gr}$$

Now, as $\theta = 45^\circ$ and $\mu = 1$
 $v' = \infty$

Option (d) is correct.

16. For the particle to just complete the circle the value of

$$u = \sqrt{5gR}$$

Particle's velocity (v) when it is at B i.e., when its velocity is vertical would be given by the relation

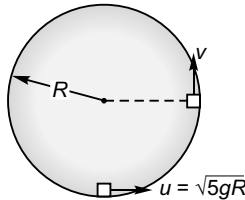

$$\begin{aligned} v^2 &= u^2 + 2(-g)R \\ &= 5gR - 2gR \\ &= 3gR \end{aligned}$$

At B :

$$a_c = \frac{v^2}{R} = 3g$$

$$\begin{aligned} a_T &= g \\ \therefore a_{\text{net}} &= \sqrt{a_c^2 + a_T^2} \\ &= \sqrt{(3g)^2 + g^2} = g\sqrt{10} \end{aligned}$$

Option (a) is correct.

17. $N = m\omega^2 r$
and $\mu N = mg$
 $\therefore \mu = \frac{g}{r\omega^2} = \frac{10}{0.2(5)^2} = 0.2$

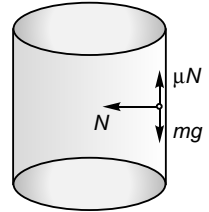

Option (c) is correct.

18. $v_{\text{max}} = \sqrt{\frac{gra}{h}} = \sqrt{\frac{10 \times 200 \times 0.75}{1.5}} = 31.62 \text{ m/s}$

19. At point A : Velocity is zero and as such its vertical component will also be zero.

At point B : Velocity is completely horizontal and as such its vertical component will again be zero.

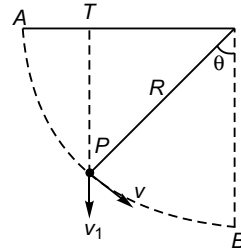

In figure, $TP = R \cos \theta$

At point P :

$$\begin{aligned} v^2 &= 2g(R \cos \theta) \\ v &= \sqrt{2gR \cos^{1/2} \theta} \\ \therefore v_{\perp} &= v \sin \theta = \sqrt{2gR \cos^{1/2} \theta} \sin \theta \end{aligned}$$

For v_{\perp} to be maximum

$$\begin{aligned} \frac{d}{d\theta} v_{\perp} &= 0 \\ \text{i.e., } \frac{d}{d\theta} \sqrt{2gR \cos^{1/2} \theta} \sin \theta &= 0 \\ \text{or } \cos^{1/2} \theta \cos \theta + \frac{1}{2} \cos^{-1/2} \theta (-\sin \theta) \sin \theta &= 0 \\ \text{or } \cos \theta \sqrt{\cos \theta} - \frac{\sin^2 \theta}{2\sqrt{\cos \theta}} &= 0 \end{aligned}$$

or $2\cos^2 \theta - \sin^2 \theta = 0$
 or $3\cos^2 \theta = 1$
 or $\theta = \cos^{-1} \frac{1}{\sqrt{3}}$

Option (b) is correct.

20. At any time

$a_t = a_c$
i.e., $\frac{dv}{dt} = \frac{v^2}{R}$
 $\therefore \int v^{-2} dv = \int \frac{dt}{R} + k$
i.e., $\frac{v^{-2+1}}{-2+1} = \frac{t}{R} + k$
 or $-\frac{1}{v} = \frac{t}{R} + k$
 At $t = 0, v = v_0$ (given)
 $\therefore -\frac{1}{v_0} = \frac{0}{R} + k$
i.e., $k = -\frac{1}{v_0}$
 Thus, $-\frac{1}{v} = \frac{t}{R} - \frac{1}{v_0}$
 or $-\frac{1}{v} = \frac{tv_0 - R}{Rv_0}$
 or $u = \frac{Rv_0}{R - tv_0}$
 or $\omega = \frac{v_0}{R - tv_0}$
i.e., $\frac{d\theta}{dt} = \frac{v_0}{R - tv_0}$
 or $d\theta = \frac{v_0}{R - tv_0} dt$
 $\int_0^{2\pi} d\theta = \int_0^T \frac{v_0}{R - tv_0} dt$
 or $2\pi = -[\log_e (R - tv_0)]_0^T$
 $= \log_e R - \log_e (R - Tv_0)$
 or $\log_e = \frac{R - Tv_0}{R} = -2\pi$
 or $1 - \frac{T}{r} v_0 = e^{-2\pi}$
 or $T = \frac{R}{v_0} (1 - e^{-2\pi})$

Option (c) is correct.

21. At highest point B

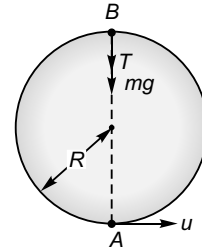

$$T + mg = \frac{mv^2}{l}$$

(where v = velocity at point B)

Thus, $T = 0$
 if $mg = \frac{mv^2}{l}$

i.e., $v^2 = gl$

If u = velocity at the lowest point A

$$v^2 = u^2 + 2(-g)(2l)$$

or $gl = u^2 - 4gh$

$\Rightarrow u^2 = 5gl$

i.e., $u = \sqrt{5gl}$

(If $T = 0, \vec{T} \cdot \vec{a} = 0$)

Option (b) is correct.

22. For any value of u at the lowest point both \vec{T} and \vec{a} will be towards the centre of the circle and thus

$\vec{T} \cdot \vec{a}$ will be positive.

Option (d) is correct.

23. Change in PE of the system

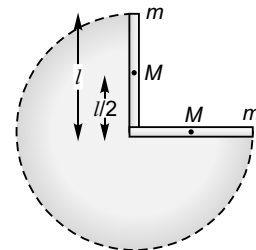

$$= Mg \frac{l}{2} + mgl$$

$$= \left(\frac{M}{2} + m \right) gl$$

24. Decrease in KE = Increase in PE

i.e., $\frac{1}{2}mu^2 = \left(\frac{M}{2} + m\right)gl$

∴ Initial speed given to ball,

$$u = \sqrt{\left(\frac{M + 2m}{m}\right)gl}$$

25. Maximum and minimum velocities will be respectively at the lowest and the highest points.

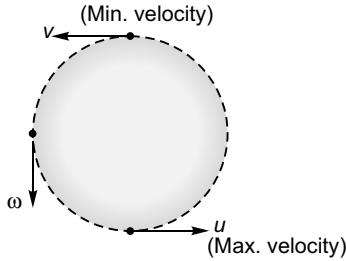

$$v^2 = u^2 + 2(-g)2L$$

$$= u^2 - 4gl$$

$$= (2v)^2 - 4gL \quad (\because u = 2v)$$

or

$$3v^2 = 4gL$$

i.e., $v = \frac{4}{3}gL = 2\sqrt{\frac{gL}{3}}$

Option (b) is correct.

26. $u = 2v = 4\sqrt{\frac{gL}{3}}$

∴ KE at the lowermost position = $\frac{1}{2}mu^2$

$$= \frac{8mgL}{3}$$

27. Let ω = velocity of the particle when moving downwards.

$$\therefore \omega^2 = v^2 + 2gL$$

$$= \frac{4gl}{3} + 2gl$$

or $\omega = \sqrt{\frac{10gl}{3}}$

Option (a) is correct.

More than One Correct Options

1. At point C :

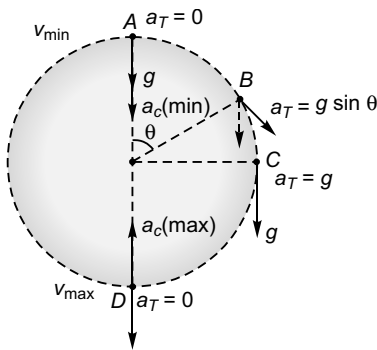

a_T is maximum and a_c is somewhere between maximum value (at D) and minimum value (at A).

∴ Option (b) is correct.

At point D :

a_c is maximum while a_T is minimum.

∴ Option (d) is correct.

2. At point B :

$$T + mg = \frac{mv'^2}{l}$$

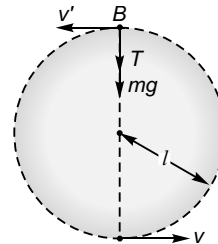

or $2mg + mg = \frac{mv'^2}{l}$

or $v'^2 = 3gl$

i.e., $v' = \sqrt{3gl}$

Option (d) is correct.

Now, $v^2 = v'^2 + 2g(2l)$

$$\therefore v^2 = 3gl + 4gl$$

$$= 7gl$$

i.e., $v = \sqrt{7gl}$

Option (b) is correct.

3. $N \sin \alpha = mg$

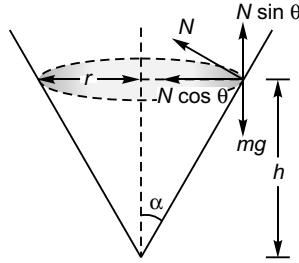

$$N \cos \alpha = mr\omega^2$$

$$\Rightarrow \tan \alpha = \frac{g}{r\omega^2} = \sqrt{\frac{g}{r \tan \theta}}$$

i.e., $\frac{2\pi}{T} = \sqrt{\frac{g}{r \tan \alpha}}$

or $T = 2\pi \sqrt{\frac{r \tan \alpha}{g}}$

If α is increase r will also increase and as such T will increase.

Option (c) is correct.

$$T = 2\pi \sqrt{\frac{h \tan^2 \alpha}{g}}$$

Thus, if h is increase, T will increase.

Option (a) is correct.

Match the Columns

1. At point B :

$$v^2 = u^2 - 2gl$$

$$= 12gl - 2gl$$

i.e., $v = \sqrt{10gl}$

$$= \sqrt{10 \times 10 \times 1}$$

$$= 10 \text{ ms}^{-1}$$

(a) \rightarrow (p).

Acceleration of bob :

$$a_c = \frac{v^2}{l} = \frac{10g}{1} = 100 \text{ ms}^{-2}$$

$$a_T = g = 10 \text{ ms}^{-2}$$

$$a_{\text{net}} = \sqrt{a_c^2 + a_T^2}$$

$$= \sqrt{100^2 + 10^2} \text{ ms}^{-2}$$

(b) \rightarrow (s).

Tension in string :

$$T = \frac{mv^2}{l} = \frac{1 \times 100}{1} = 100 \text{ N}$$

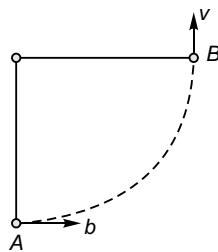

4. Particle can't have uniform motion because of change in direction of motion i.e., its velocity value. [Option (a)]

Particle can't have uniformly accelerated motion as acceleration changes direction even if speed is constant. [Option (b)]

Particle can't have not force equal to zero as centripetal force would be required for the circular motion. [Option (c)]

5. For this see figure in answer 3.

If ω is increased $N \cos \alpha$ will increase.

Thus, N will increase (as α is constant) [Option (b)]

And as such net force

$$= \sqrt{N^2 + m^2 g^2} + 2N \cos (90^\circ + \alpha)$$

on the block will increase.

\therefore Option (a) is correct.

As N increases, the value of $N \sin \alpha$ (acting opposite to mg) will increase and the block will upwards i.e., h will increase.

(c) \rightarrow (r).

Tangential acceleration of bob :

$$a_T = g = 10 \text{ ms}^{-2}$$

(d) \rightarrow (p).

2. $v = 2t$

$$\therefore \frac{dv}{dt} = 2$$

i.e., $a = 2 \text{ ms}^{-2}$

At $t = 1 \text{ s} : v = 2 \text{ ms}^{-1}$

$$\therefore a_c = \frac{v^2}{r} = \frac{2^2}{2} = 2 \text{ ms}^{-2}$$

$$a_T = 2 \text{ ms}^{-2}$$

$$\therefore a_{\text{net}} = \sqrt{2^2 + 2^2} = 2\sqrt{2} \text{ ms}^{-2}$$

Angle between \vec{a}_{net} and $\vec{v} = 45^\circ$

[As $a_c = a_T$]

$$\begin{aligned}
 \text{(a) } \vec{\mathbf{a}} \cdot \vec{\mathbf{v}} &= |\vec{\mathbf{a}}| |\vec{\mathbf{v}}| \cos 45^\circ \\
 &= \vec{\mathbf{a}}_{\text{net}} \cdot v \frac{1}{\sqrt{2}} \\
 &= 2\sqrt{2} \cdot 2 \frac{1}{\sqrt{2}} \\
 &= 4 \text{ unit.}
 \end{aligned}$$

Thus, (a) \rightarrow (r).

$$\text{(b) } |\vec{\mathbf{a}} \times \vec{\boldsymbol{\omega}}| = |\vec{\mathbf{v}}| |\vec{\boldsymbol{\omega}}| \sin 90^\circ$$

$|\vec{\boldsymbol{\omega}}$ will be perpendicular to the plane of circle]

$$\begin{aligned}
 &= a_{\text{net}} \omega \\
 &= a_{\text{net}} \frac{v}{r} \\
 &= 2\sqrt{2} \cdot \frac{2}{\sqrt{r}} \\
 &= 2\sqrt{2} \text{ unit}
 \end{aligned}$$

Thus, (b) \rightarrow (p)

$$\begin{aligned}
 \text{(c) } \vec{\mathbf{v}} \cdot \vec{\boldsymbol{\omega}} &= |\vec{\mathbf{v}}| |\vec{\boldsymbol{\omega}}| \sin 90^\circ \\
 &= v \omega = v \cdot \frac{v}{r} \\
 &= \frac{(2)^2}{2} \\
 &= 2 \text{ unit}
 \end{aligned}$$

Thus, (c) \rightarrow (q)

$$\begin{aligned}
 \text{(d) } |\vec{\mathbf{v}} \times \vec{\mathbf{a}}| &= |\vec{\mathbf{v}}| |\vec{\mathbf{a}}| \sin 45^\circ \\
 &= v a_{\text{net}} \cdot \frac{1}{\sqrt{2}} \\
 &= 4 \text{ unit}
 \end{aligned}$$

Thus, (d) \rightarrow (r)

$$3. N_1 = \frac{M}{2} \left[g - \frac{v^2 h}{ra} \right]$$

On increase v , the value of N_1 will decrease.

Thus, (a) \rightarrow (q).

$$N_2 = \frac{M}{2} \left[g + \frac{v^2 h}{ra} \right]$$

On increasing v , the value of N_2 will increase.

\therefore (b) \rightarrow (q).

As the centripetal force (F) would be provided by the frictional force (f)

$$\begin{aligned}
 F &= f \\
 \frac{F}{f} &= 1
 \end{aligned}$$

i.e.,

\therefore (c) \rightarrow (r).

If v is increased F will increase which will automatically increase the value of f .

\therefore (d) \rightarrow (p).

4. Speed of particle is constant

$$\therefore |\vec{\mathbf{a}}| = \frac{|\vec{\mathbf{v}}|^2}{|\vec{\mathbf{r}}|}$$

$$\sqrt{(-6)^2 + (b)^2} = \frac{(4)^2 + (-a)^2}{\sqrt{(3)^2 + (-4)^2}}$$

$$\sqrt{36 + b^2} = \frac{16 + a^2}{5} \quad \dots(i)$$

$$\text{(A) } \vec{\mathbf{r}} \cdot \vec{\mathbf{v}} = |\vec{\mathbf{r}}| |\vec{\mathbf{v}}| \cos 90^\circ = 0$$

$$*i.e.*, \quad (3 \hat{\mathbf{i}} - 4 \hat{\mathbf{j}}) \cdot (4 \hat{\mathbf{i}} - a \hat{\mathbf{j}}) = 0$$

$$12 + 4a = 0$$

$$a = -3$$

\therefore (a) \rightarrow (s).

(B) Substituting value of $a (= -3)$ in Eq. (i)

$$\sqrt{36 + b^2} = 5$$

$$36 + b^2 = 25$$

$$b = \sqrt{25 - 36}$$

\therefore (b) \rightarrow (s).

$$\text{(C) } \vec{\mathbf{r}} = 3 \hat{\mathbf{i}} - 4 \hat{\mathbf{j}}$$

$$\therefore r = |\vec{\mathbf{r}}| = 5$$

\therefore (c) \rightarrow (r).

$$\text{(D) } (\vec{\mathbf{v}} \times \vec{\mathbf{a}}) = |\vec{\mathbf{v}}| |\vec{\mathbf{a}}| \sin 90^\circ \hat{\mathbf{k}}$$

$$= |\vec{\mathbf{v}}| |\vec{\mathbf{a}}| \hat{\mathbf{k}}$$

$$\text{Thus, } \vec{\mathbf{r}} \cdot (\vec{\mathbf{v}} \times \vec{\mathbf{a}})$$

$$= \vec{\mathbf{r}} \cdot |\vec{\mathbf{v}}| |\vec{\mathbf{a}}| \hat{\mathbf{k}}$$

$$= (3 \hat{\mathbf{i}} - 4 \hat{\mathbf{j}}) \cdot |\vec{\mathbf{v}}| |\vec{\mathbf{a}}| \hat{\mathbf{k}} = 0$$

$$[\text{as } \hat{\mathbf{i}} \cdot \hat{\mathbf{k}} = 0, \hat{\mathbf{j}} \cdot \hat{\mathbf{k}} = 0]$$

\therefore (d) \rightarrow (s).

160 | Mechanics-1

5. (A) As speed is constant
Average speed = 1 ms^{-1}

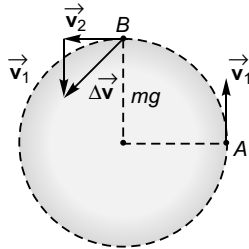

\therefore (a) \rightarrow (s)

(B) Modulus of average velocity = $\frac{AB}{t_{AB}}$

$$= \frac{R\sqrt{2}}{\frac{AB \text{ arc}}{2}} = \frac{R\sqrt{2}}{\frac{\pi R}{2}} \cdot 1 = \frac{2\sqrt{2}}{\pi}$$

\therefore (b) \rightarrow (q)

(C) Modulus of average acceleration

$$= |\vec{\mathbf{a}}_c| \text{ [as speed is constant]}$$

$$= \frac{|\vec{\mathbf{v}}_2 - \vec{\mathbf{v}}_1|}{t_{AB}} = \frac{|\Delta \vec{\mathbf{v}}|}{t_{AB}} = \frac{v\sqrt{2}}{\pi \frac{R}{2}}$$

$$= \sqrt{2} \text{ [} \because v = 1 \text{ ms}^{-1} \text{ and } R = \frac{2}{\pi}]$$

\therefore (c) \rightarrow (r)

8

Centre of Mass, Conservation of Linear Momentum, Impulse and Collision

Introductory Exercise 8.1

1. If a body is placed in a uniform gravitational field, the CG of the body coincides with the CM of the body.

$$\vec{\mathbf{r}}_{\text{CM}} = \frac{\sum_{i=1}^n m_i \vec{\mathbf{r}}_i}{\sum_{i=1}^n m_i}$$

while

$$\vec{\mathbf{r}}_{\text{CG}} = \frac{\sum_{i=1}^n m_i g_i \vec{\mathbf{r}}_i}{\sum_{i=1}^n m_i g_i}$$

If a body is placed in a uniformly increasing gravitational field ($\vec{\mathbf{g}}$) in the upward direction the CG of the body will be higher level than the CM. And, if the body is placed in a uniformly decreasing gravitational field in the upward direction the CG will be at a lower level than the CM.

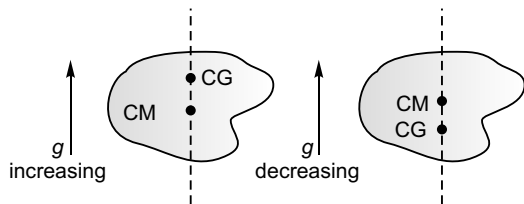

CG shifts from CM according to the magnitude and direction of the gravitational field (by some other agency *eg*, earth) in which the body is placed.

In zero gravitational field CG has no meaning while CM still exists, as usual.

2. The centre of mass of a rigid body may lie inside, on the surface and even outside the body. The CM of a solid uniform sphere is at its centre. The CM of a solid ring is at the centre of the ring which lies outside the mass of the body thus, the statement is false. (For further details see answer to 1 Assertion and Reason JEE corner).

3. Centre of mass always lies on the axis of symmetry of the body, if it exists. The statement is thus true.

4. Statement is true.

5. As more mass is towards base.

$$\text{Distance} < \frac{r}{4}$$

6. If two equal masses are kept at co-ordinates $(R, 0)$ and $(-R, 0)$, then their centre of mass will lie at origin.

7. $3 \text{ kg } (1/2, \sqrt{3}/2)$

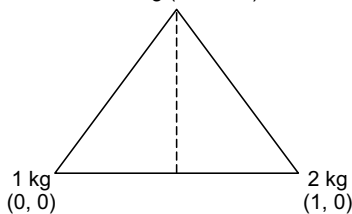

$$X_{\text{CM}} = \frac{m_1 X_1 + m_2 X_2}{m_1 + m_2}$$

$$Y_{\text{CM}} = \frac{m_1 y_1 + m_2 y_2}{m_1 + m_2}$$

$$r = \sqrt{X_{\text{CM}}^2 + Y_{\text{CM}}^2}$$

= Distance of centre of mass from A

8.

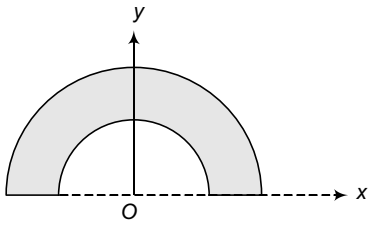

$$Y_{CM} = \frac{A_1 y_1 - A_2 y_2}{A_1 - A_2}$$

9. $A_1 = 4a^2, x_1 = a, y_1 = a$

$A_2 = a^2, x_2 = \frac{3a}{2}, y_2 = \frac{3a}{2}$

Introductory Exercise 8.2

1. Method 1

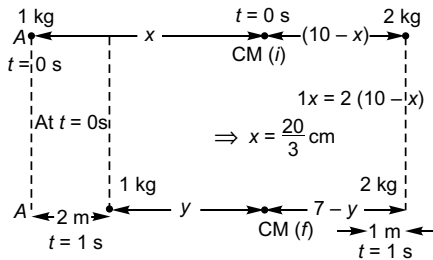

$$1x = 2(10 - x)$$

$$\Rightarrow x = \frac{20}{3} \text{ cm}$$

$$1y = 2(7 - y)$$

$$\Rightarrow y = \frac{14}{3} \text{ cm}$$

Displacement of CM

= Position of CM (f) - Position of CM (i)

$$= (y + 2) - (x)$$

$$= \left(\frac{14}{3} + 2\right) - \left(\frac{20}{3}\right)$$

$$= 0$$

Method 2

$$M v_{CM} = m_1 v_1 + m_2 v_2$$

$$= 1(2 \text{ ms}^{-1}) + 2(-1 \text{ ms}^{-1})$$

$$= 0$$

As velocity of CM is zero, there will not be any change in the position of the CM.

2.

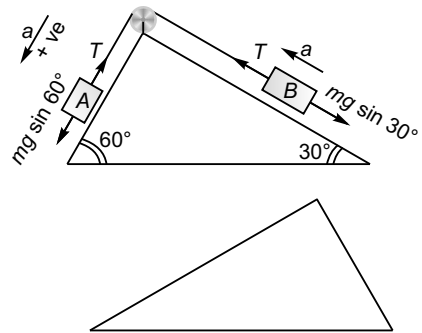

$$mg \sin 60^\circ - T = ma \quad \dots(i)$$

$$T - mg \sin 30^\circ = ma \quad \dots(ii)$$

Adding above equations,

$$mg (\sin 60^\circ - \sin 30^\circ) = 2ma$$

$$\Rightarrow a = g \left(\frac{\sqrt{3} - 1}{4} \right)$$

\vec{a}_1 and \vec{a}_2 are at right angle

$$\therefore \vec{a}_{CM} = \frac{m \vec{a}_1 + m \vec{a}_2}{2m} = \frac{1}{2}(a_1 + a_2)$$

or $|\vec{a}_{CM}| = \frac{a}{\sqrt{2}} = \frac{g(\sqrt{3} - 1)}{4\sqrt{2}}$

Introductory Exercise 8.3

1. $v_{CM} = \frac{20v + 60(+3)}{20 + 60} = 0$

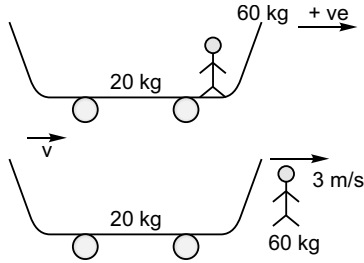

[As there is no force along horizontal direction].

\Rightarrow Velocity of trolley (v) = -9 ms^{-1}

Total energy produced by man

= KE of man + KE of trolley

$= \frac{1}{2} \times 60 \times 3^2 + \frac{1}{2} \times 20 \times (-9)^2 = 1.08 \text{ kJ}$

2. On stretching and then releasing the spring the restoring force on each block at instant will be same (according to Newton's 3rd law of motion). Now, as force is same momentum p of each block will also be same (Δt being same) [As according to Newton's second law of motion rate of change of momentum of a body is directly proportional to the net force applied on the body.]

Now, as $\text{KE} = \frac{p^2}{2m}$,

KE of blocks at any instant will be inversely proportional to their respective masses.

3. As no external force acts on the system of particles, the velocity of CM shall not change. Thus,

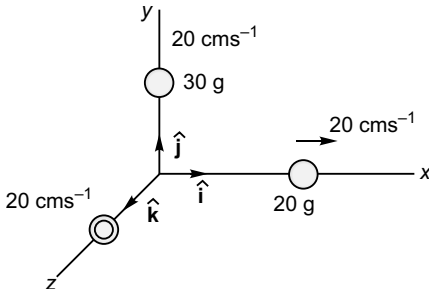

$v_{CM} = \frac{20 \times 20 \hat{i} + 30 \times 20 \hat{j} + 40 \times 20 \hat{k}}{20 + 30 + 40}$

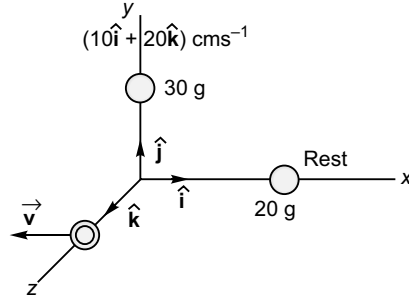

$v_{CM} = \frac{20 \times 0 + 30(10 \hat{i} + 20 \hat{j}) + 40 \vec{v}}{20 + 30 + 40}$

$300 \hat{i} + 600 \hat{j} + 40 \hat{k} = 400 \hat{i} + 600 \hat{j} + 800 \hat{k}$

$\Rightarrow 40 \vec{v} = 100 \hat{i} + 600 \hat{j} + 200 \hat{k}$

i.e., $\vec{v} = (2.5 \hat{i} + 15 \hat{j} + 5 \hat{k}) \text{ cms}^{-1}$

4. Velocity of projectile at the highest point before explosion = $10\sqrt{2} \hat{i} \text{ ms}^{-1}$

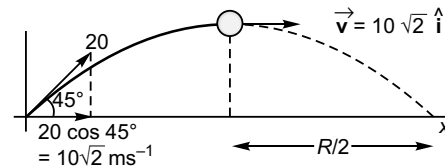

As no extra external force would be acting during explosion, the velocity of CM will not change

$\frac{m}{2} \cdot \vec{0} + \frac{m}{2} \vec{v} = 10\sqrt{2} \hat{i}$

$\Rightarrow \vec{v} = 20\sqrt{2} \hat{i}$

Range of rest half part = $\frac{R}{2} \times 2$

(as the velocity of the projectile has doubled at the highest point)

$= R = \frac{u^2}{g}$ (as $\alpha = 45^\circ$)

$= \frac{(20)^2}{10} = 40 \text{ m}$

Therefore, the rest half part will land at a distance of $\left(40 + \frac{40}{2}\right)$ m i.e., 60 m from the point of projection.

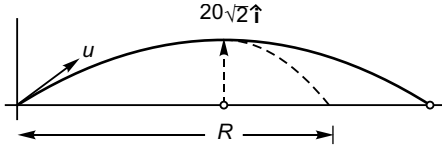

5. At point P

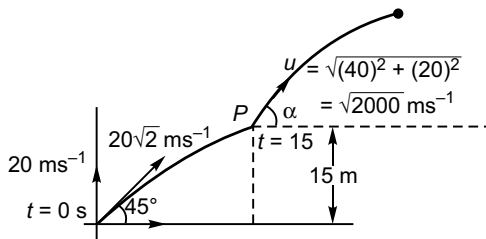

Horizontal velocity = Initial horizontal velocity

$$= 20\sqrt{2} \cos 45^\circ \text{ ms}^{-1}$$

$$= 20 \text{ ms}^{-1}$$

Vertical velocity

$$= 20\sqrt{2} \sin 45^\circ - g \cdot 1 \text{ (as } t = 1 \text{ s)}$$

$$= 70 \text{ ms}^{-1}$$

$\therefore \vec{v}$ (velocity of projectile at point P i.e., at $t = 15$ just before explosion)

$$= 20\hat{i} + 10\hat{j}$$

Now, as the projectile breaks up into two equal parts and one part comes to rest, the velocity of other half part after explosion will be

$$\vec{u} = 2\vec{v} = 40\hat{i} + 20\hat{j} \text{ ms}^{-1}$$

Angle of projection (α) of 2nd half part after explosion at point P.

$$\alpha = \tan^{-1} \left[\frac{20}{40} \right]$$

$$= \tan^{-1} \left[\frac{1}{2} \right]$$

$$\sin \alpha = \frac{1}{\sqrt{5}}$$

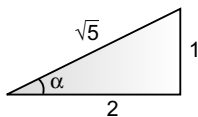

Maximum height attained by second half part

= Height of point P + Extra maximum height attained by second half part

$$= \left[20 \times 1 - \frac{1}{2} g \times 1^2 \right] + \frac{(\sqrt{2000})^2 \sin^2 \alpha}{2g}$$

$$= 15 + \frac{2000}{2 \times 10} \times \frac{1}{5}$$

$$= 15 + 20$$

$$= 35 \text{ m}$$

6. Momentum of platform + boy + stone along x-axis after throwing stone = before throwing stone

$$\therefore (60 + 40)v + 1 \left(10 \frac{1}{\sqrt{2}} \right) = 0$$

$$\Rightarrow v = -\frac{5\sqrt{2}}{100} \text{ ms}^{-1}$$

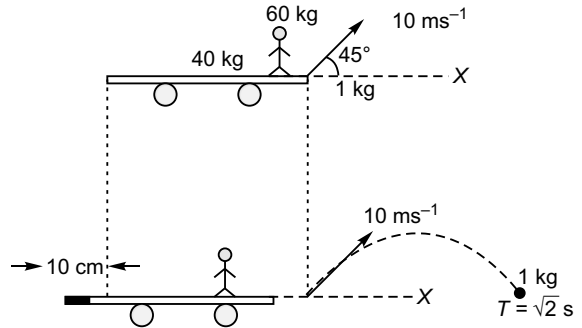

Time of flight of stone $\frac{2 \times 10 \sin 45^\circ}{g} = \sqrt{2} \text{ s}$

\therefore Horizontal displacement of platform (+ boy)

$$= v T$$

$$= -\frac{5\sqrt{2}}{100} \times \sqrt{2} = -\frac{1}{10} \text{ m} = -10 \text{ cm}$$

7. Thrust due to the upward component of the velocity of the bullet will rotate the movable end of the barrel and thus the bullet leaving the barrel will be travelling at an angle greater than 45° when it comes out of the barrel.

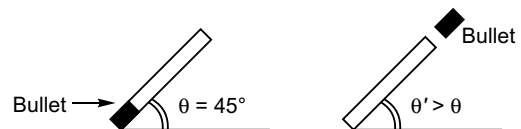

Introductory Exercise 8.4

1. To just lift rocket off the launching pad

Thrust force = Weight

or $v \left(-\frac{dm}{dt} \right) = mg$

or $\left(-\frac{dm}{dt} \right) = \frac{mg}{v}$
 $= \frac{(20 + 180) \times 9.8}{1.6 \times 10^3}$
 $= 1.225 \text{ kgs}^{-1}$

(i) Rate of consumption of fuel = 2 kgs⁻¹

∴ Time required for the consumption of fuel

$$t = \frac{180 \text{ kg}}{2 \text{ kgs}^{-1}} = 90 \text{ s}$$

Ultimate speed gained by rocket

$$v = u - gt + v \log_e \left(\frac{m_0}{m} \right) \quad \dots(i)$$

Substituting $u = 0, v = 1.6 \text{ kms}^{-1}$,

$m_0 = (20 + 180) \text{ kg}$ and $m = 20 \text{ kg}$ in Eq. (i).

$$v = -9.8 \times 90 + 1.6 \times 10^3 \ln \left(\frac{200}{20} \right)$$

$$= 2.8 \text{ kms}^{-1}$$

(iii) Rate of consumption of fuel = 20 kgs⁻¹

$$\therefore t = \frac{180 \text{ kg}}{20 \text{ kgs}^{-1}} = 9 \text{ s}$$

i.e., $v = -9.8 \times 9 + 1.6 \times 10^3 \ln \frac{200}{20}$
 $= 3.6 \text{ kms}^{-1}$

2. Mass at time $t, m = m_0 - \mu t$

$$\therefore \frac{dm}{dt} = -\mu$$

$ma = \text{thrust force} - mg$

or $ma = v \left(-\frac{dm}{dt} \right) - mg$

or $ma = \mu v - mg$

or $(m_0 - \mu t) \frac{d^2x}{dt^2} = \mu u - (m_0 - \mu t)g$ ($\because v = u$)

3. $v = u - gt + v \ln \left(\frac{m_0}{m} \right)$

$$= 0 - gt + u \ln \frac{m_0}{m_0 \left(1 - \frac{t}{3} \right)}$$

$$= -g1 + u \ln \frac{3}{2} \quad (\text{at } t = 1 \text{ s})$$

$$= u \ln \frac{3}{2} - g$$

Introductory Exercise 8.5

1. \vec{u} (at $t = 0 \text{ s}$) = $(10\sqrt{3} \hat{i} + 10 \hat{j}) \text{ ms}^{-1}$

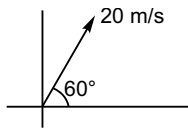

At $t = 1 \text{ s}$

Horizontal velocity = $10\sqrt{3} \hat{i} \text{ ms}^{-1}$

Vertical velocity = $(10 - g \cdot 1) \hat{j} \text{ ms}^{-1}$
 $= 0 \hat{j} \text{ ms}^{-1}$

$$\therefore \vec{v} = 10\sqrt{3} \hat{i} \text{ ms}^{-1}$$

Change in velocity, $\Delta \vec{v} = \vec{v} - \vec{u}$

$$= (10\sqrt{3}) \hat{i} - (10\sqrt{3} \hat{i} + 10 \hat{j})$$

$$= -10 \hat{j} \text{ ms}^{-1}$$

i.e., $\Delta \vec{v} = 10 \text{ ms}^{-1}$, downwards.

2. Impulse (\vec{J}) imparted

= Change in momentum in the time interval

$$t = 0 \text{ s to } t = 2 \text{ s}$$

$$= m [(\text{Velocity at } t = 2 \text{ s})$$

$$- (\text{Velocity at } t = 0 \text{ s})]$$

$$= 2 \text{ kg} [(4 \hat{i} + 4 \hat{j}) \text{ ms}^{-1} - (4 \hat{j}) \text{ ms}^{-1}]$$

$$= 8 \hat{i} \text{ Ns} \quad (\because 1 \text{ kg ms}^{-1} = 1 \text{ Ns})$$

3. Spring will become taut when the ball would go down by 2 m.

$$v^2 = u^2 + 2 \times g \times 2$$

or $v = 2\sqrt{10} \text{ ms}^{-1}$

$$\Delta p = m \Delta v$$

$$= 1(2\sqrt{10} - 0) \text{ kg ms}^{-1}$$

$$= 2\sqrt{10} \text{ kg ms}^{-1}$$

∴ Impulse imparted = $2\sqrt{10} \text{ Ns}$.

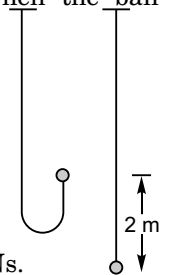

Introductory Exercise 8.6

1. At maximum extension of the spring both blocks will move with same velocity v .

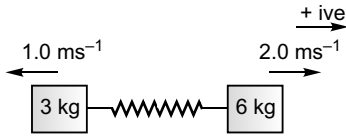

$$\begin{aligned} \therefore (-1.0) \times 3 + (+2.0) \times 6 &= (3 + 6)v \\ \Rightarrow v &= +1 \text{ m/s} \end{aligned}$$

Applying law of conservation of mechanical energy

$$\frac{1}{2} 3(-1)^2 + \frac{1}{2} 6(2)^2 = \frac{1}{2} 9 \times 1^2 + \frac{1}{2} 6v^2$$

Substituting $k = 200 \text{ Nm}^{-1}$
 $x = 0.3 \text{ m} = 30 \text{ cm}$

2. Kinetic energy of particle = K

$$\Rightarrow \frac{1}{2} mv^2 = K$$

$$\therefore v = \sqrt{\frac{2K}{m}}$$



During collision the EPE of the system would be at its maximum value when both the particles move with same velocity V given by the relation

$$\begin{aligned} mv + m \times 0 &= (m + m)V \\ \text{(Law of conservation of momentum)} \\ \Rightarrow V &= \frac{v}{2} \\ &= \frac{1}{2} \sqrt{\frac{2K}{m}} \end{aligned}$$

Applying law of conservation of mechanical energy

$$\begin{aligned} K + 0 &= \frac{1}{2} (m + m) V^2 + \text{EPE}_{\max} \\ \text{or } K &= mV^2 + \text{EPE}_{\max} \\ \text{or } K &= m \cdot \frac{1}{4} \left(\frac{2K}{m} \right) + \text{EPE}_{\max} \\ \text{or } \text{EPE}_{\max} &= \frac{K}{2} \end{aligned}$$

3. Let us consider the following case

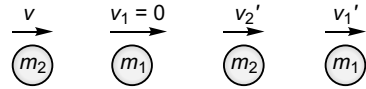

$$\begin{aligned} v_2' &= \left(\frac{m_1 - m_2}{m_1 + m_2} \right) v_2 + \left(\frac{2m_2}{m_1 + m_2} \right) v_1 \\ &= \frac{m_1 - m_2}{m_1 + m_2} v_2 \quad (\text{as } v_1 = 0) \end{aligned}$$

ΔK (Transfer of KE of particle of mass m_2)

$$\begin{aligned} &= \frac{1}{2} m_2 v_2'^2 - \frac{1}{2} m_2 v_2^2 \\ &= \frac{1}{2} m_2 v_2^2 - \frac{1}{2} m_2 \left[\frac{m_1 - m_2}{m_1 + m_2} v_2 \right]^2 \\ &= \frac{1}{2} m_2 v_2^2 \left[1 - \left(\frac{m_1 - m_2}{m_1 + m_2} \right)^2 \right] \end{aligned}$$

From above we conclude that ΔK will be maximum when

$$\begin{aligned} m_1 - m_2 &= 0 \\ \text{i.e., } \frac{m_2}{m_1} &= 1 \end{aligned}$$

4. Continuing from the previous answer

$$\begin{aligned} \frac{\Delta K}{K} &= 1 - \left(\frac{m_1 - m_2}{m_1 + m_2} \right)^2 \\ &= \frac{(m_1 + m_2)^2 - (m_1 - m_2)^2}{(m_1 + m_2)^2} \\ &= \frac{4m_1 m_2}{(m_1 + m_2)^2} \end{aligned}$$

5. Substituting $m_2 = m$ and $m_1 = 2m$ in the result of the previous question no. 4.

$$\begin{aligned} \frac{\Delta K}{K} &= \frac{4(2m)(m)}{(2m + m)^2} \\ &= \frac{8}{9} \end{aligned}$$

6. As the collision is elastic

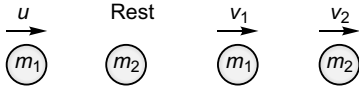

$$v_1 = \frac{m_1 - m_2}{m_1 + m_2} u$$

and

$$\begin{aligned} v_2 &= v_1 + u \\ &= \frac{m_1 - m_2}{m_1 + m_2} u + u \\ &= \frac{2m_1}{(m_1 + m_2)} u \end{aligned}$$

Before first collision of B with C

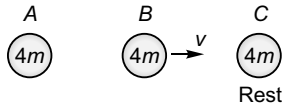

After collision of B with C

$$\begin{aligned} v_{B_1} &= \frac{m - 4m}{m + 4m} v \\ &= -\frac{3}{5} v \end{aligned}$$

and $v_{C_1} = -\frac{3}{5} v + v = \frac{2}{5} v$

Before second collision of B with A

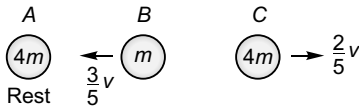

$$\begin{aligned} v_{B_2} &= \frac{m - 4m}{m + 4m} \left(-\frac{3}{5} v\right) \\ &= \frac{9}{25} v \end{aligned}$$

$$v_{A_2} = \frac{9}{25} v + \left(-\frac{3}{5} v\right) = -\frac{6}{25} v$$

After second collision : of B with A

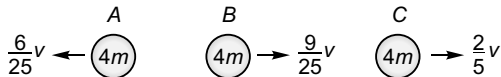

As velocity of C is greater than that of B, no further collision will take place.

∴ Total number collisions between the balls = 2.

$$7. v'_2 = \frac{m_2 - m_1}{m_1 + m_2} v_2 + \frac{2m_1}{m_1 + m_2} v_1$$

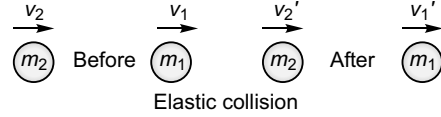

$$v'_1 = \frac{m_1 - m_2}{m_1 + m_2} v_1 + \frac{2m_2}{m_1 + m_2} v_2$$

We see that $v'_2 \neq v_1$ and $v'_1 \neq v_2$.

However, if $m_1 = m_2$

$$v'_2 = v_1 \text{ and } v'_1 = v_2$$

Ans. No.

8. In elastic collision of two bodies of equal masses, the velocities get interchanged.

Before collision of A with B

velocity of A = +v

velocity of B = zero

Therefore, after collision of A with B

velocity of A = zero

velocity of B = +v

After collision of B with wall

velocity of B = -v

Before collision of B with A

velocity of A = zero

velocity of B = -v

Therefore, after collision of B with A

velocity of A = -v

velocity of B = zero

Now, no more collision will take place as A will move towards left with speed v leaving B at rest to its right side.

Thus, we see that speeds of the balls remains unchanged after all the possible collisions have taken place.

Introductory Exercise 8.7

1. Applying law of conservation of momentum

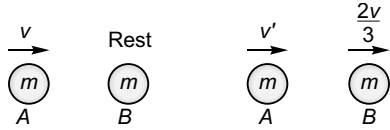

$$mv = mv' + m \cdot \frac{2v}{3}$$

i.e.,

$$v' = \frac{v}{3}$$

$$e = \frac{\text{velocity of separation}}{\text{velocity of approach}}$$

$$= \frac{2v - v'}{v - 0} = \frac{2v - \frac{v}{3}}{v} = \frac{1}{3}$$

2. $v'_1 = \left(\frac{1+e}{2}\right)v$ and $v'_2 = \left(\frac{1-e}{2}\right)v$

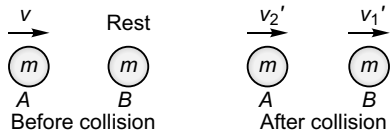

KE after collision = 0.2 J (given)

$$\therefore \frac{1}{2}mv_2'^2 + \frac{1}{2}mv_1'^2 = 0.2$$

or $v_2'^2 + v_1'^2 = 4$ ($\because m = 0.1 \text{ kg}$)

or $\left(\frac{1-e}{2}\right)^2 v^2 + \left(\frac{1+e}{2}\right)^2 v^2 = 4$

or $\frac{v^2}{4}(2+2e^2) = 4$

Extreme cases

If collision is perfectly in elastic i.e., $e = 0$

$$\frac{v^2}{4}(2) = 4$$

i.e., $v = 2\sqrt{2} \text{ m/s}$

If collision is perfectly elastic i.e., $e = 1$

$$\frac{v^2}{4}(2+2) = 4$$

i.e., $v = 2 \text{ m/s}$

$$\therefore v_{\min} = 2 \text{ m/s}$$

$$v_{\max} = 2\sqrt{2} \text{ m/s}$$

3. A (m) hitting B(2m)

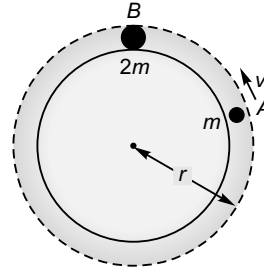

A collision is elastic

$$v_B = \frac{2(m)}{2m+m}v = \frac{2}{3}v$$

and

$$v_A = \frac{m-2m}{2m+m}v = -\frac{v}{3}$$

\therefore Velocity of B w.r.t. A = $v_B - v_A$

$$= \frac{2}{3}v - \left(-\frac{v}{3}\right) = v$$

\therefore Next collision between the balls will take place after time

$$t = \frac{2\pi r}{v}$$

4. As collision is elastic

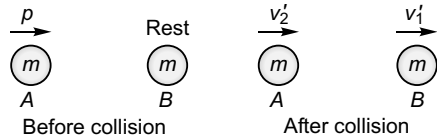

$$v'_2 = \left(\frac{1-e}{2}\right)\frac{p}{m}$$

Now, Momentum of A before impact

– Impulse given by B on A

= Momentum of A after impact.

$$\therefore p - J = mv'_2$$

or $p - J = m\left(\frac{1-e}{2}\right)\frac{p}{m}$

or $e = \frac{2J}{p} - 1$

Introductory Exercise 8.8

1. $v_0 \sin \alpha = v \cos(\alpha + \beta)$

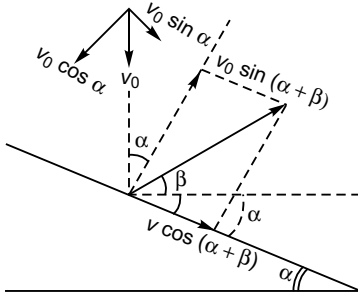

$v_0 \cos \alpha = v \sin(\alpha + \beta)$ (Impact being elastic)

$\therefore \tan \alpha = \cot(\alpha + \beta)$

or $\cot \frac{\pi}{2} - \alpha = \cot(\alpha + \beta)$

or $\frac{\pi}{2} - \alpha = \alpha + \beta$

or $\beta = \frac{\pi}{2} - 2\alpha$

2. Speed after n impacts

Speed before first impact $= u (= \sqrt{2gh})$

Speed before one impact $= eu$

Speed after 2 impacts $= e(eu) = e^2u$

.....

Speed after n impacts $= e^n u$

Height (H) upto which the ball rebounds after n th rebound

$$H = \frac{(e^n u)^2}{2g} = \frac{e^{2n} u^2}{2g} = e^{2n} \cdot h$$

3. $mv + 0 = 0 + MV$

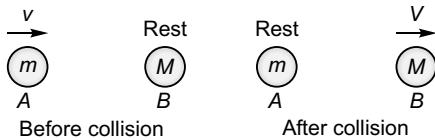

$\Rightarrow V = \frac{m}{M} v$

$e = \frac{\text{Velocity of separation}}{\text{Velocity of approach}}$

$$= \frac{V - 0}{v - 0} = \frac{V}{v} = \frac{m}{M}$$

4.

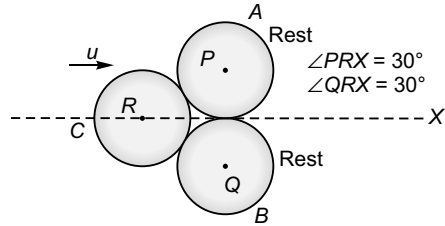

As the balls are of same size, the centres of the balls P, Q and R will be at vertices of an equilateral triangle when ball C just strikes balls A and B symmetrically and as such the balls A and B will follow the path as shown below

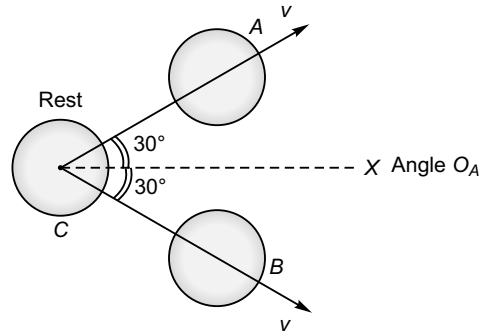

Applying law of conservation of momentum

$mu =$ Resultant momentum of A and B balls along the axis of X .

or $mu = 2mv \cos 30^\circ$

or $u = 2v \frac{\sqrt{3}}{2}$

or $u = v\sqrt{3}$

As the ball C will strike ball A (and as well as ball B) with velocity $u \cos 30^\circ$

Velocity of approach of ball C towards ball A
 $= u \cos 30^\circ - 0$
 $= u \cos 30^\circ$
 $= u\sqrt{3}$

Velocity of separation of ball A away from ball C = v

$$\begin{aligned} \therefore e &= \frac{v}{\frac{u\sqrt{3}}{2}} \\ &= \frac{v}{u\sqrt{3}} \cdot \frac{\sqrt{3}}{2} \\ &= \frac{2}{3} \end{aligned}$$

5. x-component of velocity

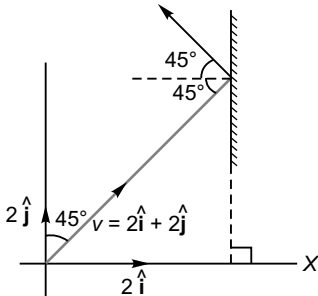

before impact = $2\hat{i}$
 \therefore after impact = $-e2\hat{i}$
 $= -\frac{1}{2} \times 2\hat{i}$
 $= -\hat{i}$
 y-component of velocity
 before impact = $2\hat{j}$

\therefore after impact = $2\hat{j}$
 \therefore Velocity after impact = $-\hat{i} + 2\hat{j}$

6. At A, $u_{\parallel} = u \cos \theta$
 $u_{\perp} = u \sin \theta$

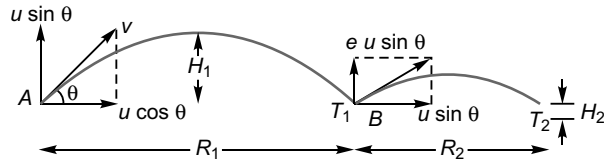

\therefore At B

$$\begin{aligned} u_{\parallel} &= u \cos \theta \\ u_{\perp} &= e u \sin \theta \\ \frac{T_1}{T_2} &= \frac{g}{2eu \sin \theta} = \frac{1}{e} \end{aligned}$$

[Using $T = \frac{2u_{\perp}}{g}$]

$$\begin{aligned} \frac{R_1}{R_2} &= \frac{2(u \sin \theta)(u \cos \theta)}{2(eu \sin \theta)u \cos \theta} \left[\text{Using } R = \frac{2u_{\parallel}u_{\perp}}{g} \right] \\ &= \frac{1}{e} \\ &= \frac{(u \sin \theta)^2}{2g} \left[\text{Using } H = \frac{u_{\perp}^2}{2g} \right] \\ \frac{H_1}{H_2} &= \frac{2g}{(eu \sin \theta)^2} \\ &= \frac{1}{e^2} \end{aligned}$$

AIEEE Corner

Subjective Questions (Level 1)

1.

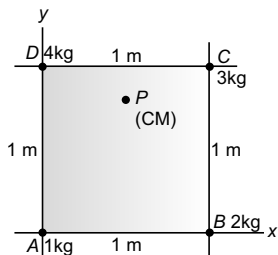

$$\begin{aligned} x_{CM} &= \frac{1 \cdot 0 + 2 \cdot 1 + 3 \cdot 1 + 4 \cdot 0}{1 + 2 + 3 + 4} \\ &= \frac{5}{10} \text{ m} \\ y_{CM} &= \frac{1 \cdot 0 + 2 \cdot 0 + 3 \cdot 1 + 4 \cdot 1}{1 + 2 + 3 + 4} \\ &= \frac{7}{10} \text{ m} \end{aligned}$$

$$AP^2 = x_{CM}^2 + y_{CM}^2 = \left(\frac{5}{10}\right)^2 + \left(\frac{7}{10}\right)^2$$

$$= 0.74 \text{ m}^2$$

$$2. \quad x_{CM} = \frac{A_1 x_1 + A_2 x_2}{A_1 + A_2}$$

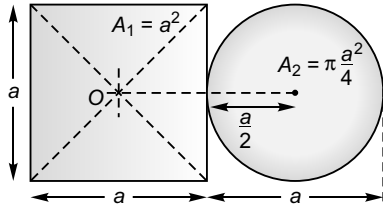

$$= \frac{a^2 \cdot 0 + \frac{\pi a^2}{4} \cdot (a)}{a^2 + \frac{\pi a^2}{4}}$$

$$= \frac{\pi}{4 + \pi} a$$

3. Let A = area of rectangle

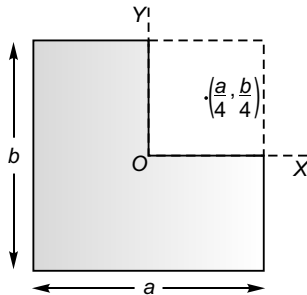

$$x_{CM} = \frac{A \cdot 0 + \left(-\frac{A}{4}\right) \frac{a}{4}}{A + \left(-\frac{A}{4}\right)}$$

$$= -\frac{A}{4} \cdot \frac{4}{3A} \cdot \frac{a}{4}$$

$$= -\frac{a}{12}$$

$$y_{CM} = \frac{A \cdot 0 + \left(-\frac{A}{4}\right) \frac{b}{4}}{A + \left(-\frac{A}{4}\right)}$$

$$= -\frac{b}{12}$$

Centre of mass $\left(-\frac{a}{12}, -\frac{b}{12}\right)$

$$4. \quad x_{CM} = \frac{V \cdot 0 + \left(-\frac{4}{3} \pi a^3\right) b}{V - \frac{4}{3} \pi a^3}$$

$$= \frac{-\frac{4}{3} \pi a^3 b}{\frac{4}{3} \pi R^3 - \frac{4}{3} \pi a^3}$$

$$= -\left(\frac{a^3}{R^3 - a^3}\right) b$$

By symmetry $y_{CM} = 0$

5. In Fig. 1, C is CM.

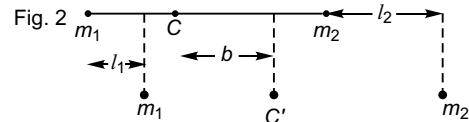
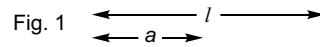

$$\therefore m_1 a = m_2 (l - a) \quad \dots (i)$$

In Fig. 2, C' is CM.

$$m_1 (a + b - l_1) = m_2 (l - a + l_2 - b) \dots (ii)$$

Substituting Eq. (i) in Eq. (ii),

$$m_1 (b - l_1) = m_2 (l_2 - b)$$

$$\text{or } m_1 b - m_1 l_1 = m_2 l_2 - m_2 b$$

$$\text{or } (m_1 + m_2) b = m_1 l_1 + m_2 l_2$$

$$\text{or } b = \frac{m_1 l_1 + m_2 l_2}{m_1 + m_2}$$

$$6. \quad x_{CM} = \frac{\int x \, dm}{\int dm}$$

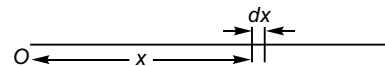

where, dm = mass of element of length dx .

$$= \frac{\int x \rho \, dx \, A}{\int \rho \, dx \, A}$$

$$= \frac{\int_0^l x \left(\rho_0 \frac{x^2}{l^2}\right) dx}{\int_0^l \left(\rho_0 \frac{x^2}{l^2}\right) dx} \quad (\because \rho = \rho_0 \frac{x^2}{l^2})$$

$$= \frac{\int_0^l x^3 \, dx}{\int_0^l x^2 \, dx}$$

$$= \left[\frac{3}{x^3} \cdot \frac{x^4}{4} \right]_0^l$$

$$= \frac{3}{4} l$$

7. $x_{CM} = \frac{1 \times 10 + 2 \times 12}{1 + 2}$

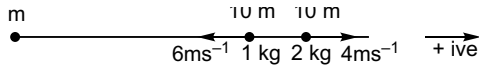

$$= \frac{34}{3} \text{ m}$$

$$v_{CM} = \frac{1 \times (-6) + 2 \times (+4)}{1 + 2} = + \frac{2}{3} \text{ ms}^{-1}$$

x'_{CM} (new position of CM)

$$= \frac{34}{3} \text{ m} + 2 \text{ s} \left(\frac{2}{3} \text{ ms}^{-1} \right)$$

$$= \frac{38}{3} \text{ m} = 12.67 \text{ m}$$

8. $v_{CM} = \frac{1 \times 2(+2) + 2 \times (-1)}{1 + 2}$

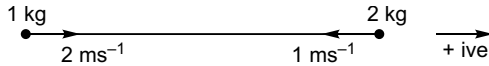

$$= 0 \text{ ms}^{-2}$$

∴ Displacement of CM in 1 s = 0 m.

9. Acceleration (\vec{a}) = $-10 \hat{j} \text{ ms}^{-2}$

$$\vec{v} = \vec{u} + \vec{a} t$$

$$= \frac{(1)(0) + (2)(10\hat{i} + 10\hat{j})}{3} - 10\hat{j}$$

$$= \left(\frac{20}{3}\hat{i} - \frac{10}{3}\hat{j} \right) \text{ m/s}$$

New position vector (\vec{r}_1) of particle A

$$(\vec{r}_1) = \vec{s}_0 + \vec{u} t + \frac{1}{2} \vec{a} t^2$$

$$= (10\hat{i} + 20\hat{j}) + \vec{0} + \frac{1}{2}(-10\hat{j}) \cdot 1^2$$

$$= 10\hat{i} + 15\hat{j} \text{ m}$$

New position vector (\vec{r}_2) of particle B

$$\vec{r}_2 = (20\hat{i} + 40\hat{j}) + (10\hat{i} + 10\hat{j}) \cdot 1 + \frac{1}{2}(-10\hat{j}) \cdot 1^2$$

$$= 30\hat{i} + 45\hat{j}$$

New position of CM

$$\vec{R} = \frac{\vec{r}_1(1) + \vec{r}_2(2)}{1 + 2}$$

$$= \frac{10\hat{i} + 15\hat{j} + 60\hat{i} + 90\hat{j}}{3}$$

$$= \frac{70\hat{i} + 105\hat{j}}{3} \text{ m}$$

10.

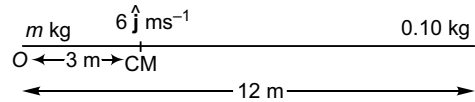

(a) $3 = \frac{m \cdot 0 + 0.1 \times 12}{m + 0.1}$

⇒ $m = 0.3 \text{ kg}$

(b) Momentum of system = Momentum of CM

$$= (m + 0.1) \text{ kg} \times 6\hat{j} \text{ ms}^{-1}$$

$$= 2.4\hat{j} \text{ kg ms}^{-1}$$

(c) $\vec{v}_{CM} = \frac{\vec{v}_m(0.3) + \vec{0}(0.10)}{0.3 + 0.1}$

$$\vec{v}_m = \frac{4}{4} \vec{v}_{CM}$$

$$= \frac{4}{3} \times 6\hat{j} \text{ ms}^{-1}$$

$$= 8\hat{j} \text{ m s}^{-1}$$

11.

$$A \bullet t = 0 \text{ s}$$

$$B \bullet (t = 100 \text{ ms})$$

Position of 1st particle (A) at $t = 300 \text{ ms}$

$$s_1 = \frac{1}{2} \times 10 \times (300 \times 10^{-3})^2$$

$$= 0.45 \text{ m}$$

Position of 2nd particle (B) at $t = 300 \text{ ms}$

(B is at the position of A at $t = 100 \text{ ms}$)

$$s_2 = \frac{1}{2} \times 100 \times (200 \times 10^{-3})^2$$

$$= 0.20 \text{ m}$$

∴ Position of CM = $\frac{2m \times 0.2 + m \times 0.45}{2m + m}$

$$= 28.3 \text{ cm}$$

Velocity of 1st particle (A) at $t = 300$ ms

$$v_1 = 10 \times 300 \times 10^{-3} = 3 \text{ ms}^{-1}$$

Velocity of 2nd particle at $t = 300$ ms

$$v_2 = 10 \times 200 \times 10^{-3} \text{ ms}^{-1} = 2 \text{ ms}^{-1}$$

$$\begin{aligned} \therefore v_{\text{CM}} &= \frac{2m \times 2 + m \times 3}{2m + m} \\ &= \frac{7}{3} = 2.33 \text{ ms}^{-1} \end{aligned}$$

12. $24 = \frac{m_A \cdot 0 + m_B \cdot 80}{m_A + m_B}$

or $24(m_A + 0.6) = 80 \times 0.6$

or $m_A = 1.4 \text{ kg}$

\therefore Total mass of system = $1.4 \text{ kg} + 0.6 \text{ kg} = 2.0 \text{ kg}$

$$v_{\text{CM}} = 6.0 t^2 \hat{j}$$

$\therefore a_{\text{CM}} = 12 t \hat{j} \text{ ms}^{-2}$

Net force acting on system (at $t = 3$ s)

= Total mass of system $\times (a_{\text{COM}}$ at $t = 3$ s)

= $2.0 \text{ kg} \times 36 \hat{j} \text{ ms}^{-2}$

= $72 \text{ N } \hat{j}$

13.

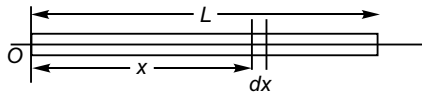

$$\begin{aligned} x_{\text{CM}} &= \frac{\int x dm}{\int dm} \\ &= \frac{\int_0^L x (Ax dx)}{\int_0^L Ax dx} \\ &= \frac{\int_0^L x^2 dx}{\int_0^L x dx} \\ &= \frac{L^3 / 3}{L^2 / 2} \\ &= \frac{2}{3} L \end{aligned}$$

14. Let $x =$ displacement of wedge (30 kg) towards right.

\therefore Displacement of block A towards right (along x -axis) when it arrives at the bottom of the wedge

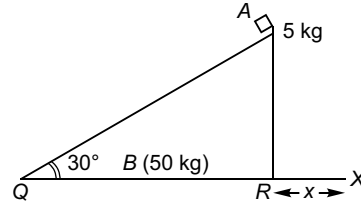

$$\begin{aligned} &= QR - x \\ &= 0.5 - x \end{aligned}$$

Now, as net force on the system (wedge + block) along x -axis is zero, the position of CM of the system, along x -axis, will not change

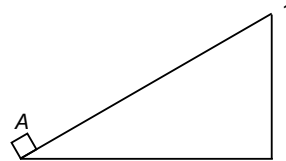

$$\begin{aligned} \therefore 5(0.5 - x) &= 30x \\ \text{i.e., } x &= \frac{0.5}{7} \text{ m} \\ &= 71.4 \text{ mm} \end{aligned}$$

15. As no external force acts on the system, the velocity of CM will be zero.

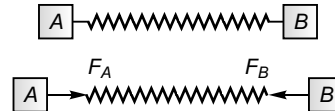

i.e., $\frac{m_A v_A + m_B v_B}{m_A + m_B} = 0$

i.e., $\frac{v_A}{v_B} = -\frac{m_B}{m_A} = -\frac{2}{1}$

(a) \therefore Ratio of speeds = 2

(b) $\frac{p_A}{p_B} = \frac{m_A v_A}{m_B v_B} = \frac{m_A}{m_B} \left(-\frac{m_B}{m_A} \right) = -1$

(c) $\frac{K_A}{K_B} = \frac{p_A^2 / 2m_A}{p_B^2 / 2m_B} = \frac{p_A^2}{p_B^2} \times \frac{m_B}{m_A} = \frac{2}{1}$

16. While man travels from P to Q

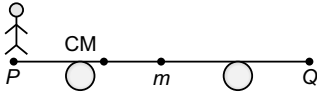

$$v_{CM} = \frac{m \left(\frac{3v}{2} - v \right) + mv}{m + m} = \frac{3v}{4}$$

Displacement of CM (along horizontal) = $\frac{L}{2}$.

\therefore Time taken by man to reach point Q starting from point P

$$t_{PQ} = \frac{L/2}{3v/4} = \frac{2L}{3v}$$

While man travels from Q to P

$$v_{CM} = \frac{m \left(-\frac{3v}{2} - v \right) + mv}{m + m} = -\frac{3v}{4}$$

Displacement of CM = $-\frac{1}{2}L$

\therefore Time taken by man to reach point P starting from point Q

$$t_{QP} = \frac{-L/2}{-3v/4} = \frac{2L}{3v}$$

\therefore Total time = $t_{PQ} + t_{QP}$

$$= \frac{2L}{3v} + \frac{2L}{3v} = \frac{4L}{3v}$$

\therefore Net displacement of trolley = $\frac{4L}{3v} \times v = \frac{4L}{3}$

17. (a) While the man climbs in the rope, no extra external net force acts on the system (balloon along with rope + man). Force applied by man to gain velocity to climb up is an internal force and as such the velocity of the CM of the system will remain stationary.

$$mv + (M + m)V = 0$$

or
$$V = -\frac{m}{(M + m)}v$$

Negative sign shows that the balloon will move downwards.

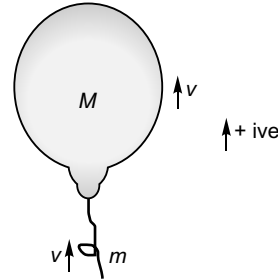

(b) If the man stops climbing *i.e.*, $v = 0$, then according to the above relation the value of v will also be zero. Thus, the balloon will also stop.

18.

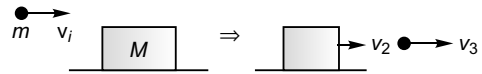

$$mv_1 = Mv_2 + mv_3 \quad \dots(i)$$

$$m = 4 \times 10^{-3} \text{ kg}$$

$$M = 1 \text{ kg}$$

$$v_3 = 100 \text{ m/s}$$

$$v_1 = 500 \text{ m/s}$$

Find v_2

$$(a) 0 = v_2^2 - 2as = v_2^2 - 2(\mu g)s$$

$$\therefore \mu = \frac{v_2^2}{2gs}$$

Here $s = 0.30 \text{ m}$

(b) Decrease in kinetic energy of bullet

$$= \frac{1}{2}m(v_1^2 - v_3^2)$$

$$(c) \text{ KE of block} = \frac{1}{2}Mv_2^2$$

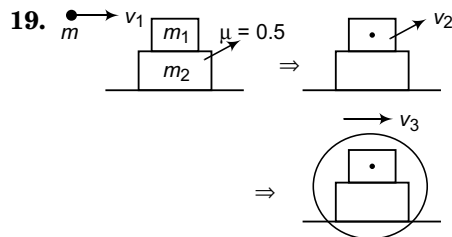

$$(m + m_1)v_2 = mv_1$$

$$\therefore v_2 = \frac{mv_1}{m + m_1} \quad \dots(i)$$

$$\text{Common velocity } v_3 = \frac{mv_1}{m + m_1 + m_2} \quad \dots(ii)$$

For m_1 : $v_3^2 = v_2^2 - 2a_1s_1$ and Find s_1

For m_2 : $v_3^2 = 2a_2s_2$ and Find s_2

$$\text{Here : } a_1 = \frac{\mu m_1 g}{m_1} = \mu g$$

$$\text{and } a_2 = \frac{\mu m_1 g}{m_2}$$

20. Let v = Velocity of pendulum bob when the pendulum is vertical

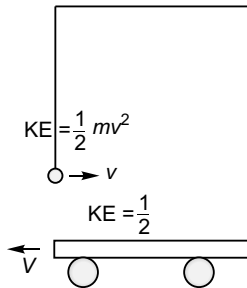
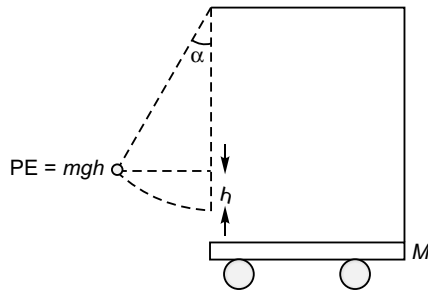

V = Velocity of wagon when pendulum is vertical

$$\therefore mv = MV$$

$$\text{or } v = \frac{M}{m} V$$

KE of wagon + KE of bob = PE of bob

$$\frac{1}{2}MV^2 + \frac{1}{2}mv^2 = mgh$$

$$\text{or } \frac{1}{2}MV^2 + \frac{1}{2}m\left(\frac{M}{m}V\right)^2 = mgh$$

$$\text{or } \frac{1}{2}MV^2 \left[1 + \frac{M}{m}\right] = mgh$$

$$\text{or } \frac{1}{2}MV^2(M + m) = m^2gh$$

$$\text{or } V^2 = \frac{2m^2gh}{M(M + m)}$$

$$\text{or } V^2 = \frac{2m^2gl(1 - \cos \alpha)}{M(M + m)}$$

$$\text{or } V^2 = \frac{2m^2gl2\sin^2 \frac{\alpha}{2}}{M(M + m)}$$

$$\text{or } V = 2m \sin \frac{\alpha}{2} \sqrt{\frac{gl}{M(M + m)}}$$

21. Let the track shift by x (to the right) when the cylinder reaches the bottom of the track.

$$\therefore x' + x = R - r$$

$$\text{or } x' = (R - r) - x$$

(x' = horizontal displacement of cylinder w.r.t. ground)

As no force would be acting along horizontal direction, for no shift in CM along horizontal. We would have

$$mx' - Mx = 0$$

$$\text{or } m[(R - r) - x] - Mx = 0$$

$$\text{or } (M + m)x = m(R - r)$$

$$\Rightarrow x = \frac{m(R - r)}{M + m}$$

Now, as the PE of the cylinder would change into the kinetic energies of the

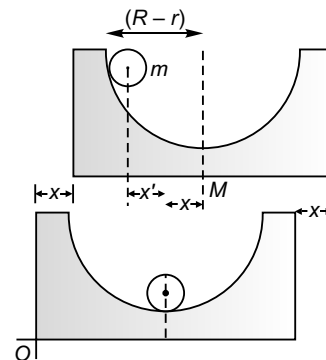

cylinder and the track we have,

$$mg(R - r) = \frac{1}{2}mv^2 + \frac{1}{2}MV^2 \quad \dots(i)$$

where, v = velocity of cylinder

and V = velocity of track.

(when cylinder just reaches bottom of the track)

176 | Mechanics-1

Applying law of conservation of momentum

$$mv + MV = 0$$

or
$$v = -\frac{M}{m}V$$

Thus, Eq. (i) becomes

$$mg(R - r) = \frac{1}{2}m\left(-\frac{M}{m}V\right)^2 + \frac{1}{2}MV^2$$

or
$$mg(R - r) = \frac{1}{2}MV^2\left[\frac{M}{m} + 1\right]$$

or
$$V^2 = \frac{2m^2g(R - r)}{M(M + m)}$$

or
$$V = m\sqrt{\frac{2g(R - r)}{M(M + m)}}$$

22. No change in momentum of ball and also that of wall along horizontal direction.

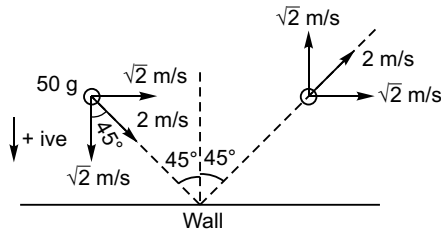

Along perpendicular direction :

Momentum of ball after reflection

$$(\vec{p}_f) = -50 \times 10^{-3} \sqrt{2} \text{ kg ms}^{-1}$$

Momentum of ball before reflection

$$(\vec{p}_i) = +50 \times 10^{-3} \sqrt{2} \text{ kg ms}^{-1}$$

$$\begin{aligned} \therefore \Delta \vec{p} &= \vec{p}_f - \vec{p}_i \\ &= -100 \times 10^{-3} \sqrt{2} \text{ kg ms}^{-1} \\ &= -0.14 \text{ kg ms}^{-1} \end{aligned}$$

i.e., $|\Delta \vec{p}| = 0.14 \text{ kg ms}^{-1}$

Momentum of wall (when ball strikes wall)

$$\vec{p}_i = 50 \times 10^{-3} \times \sqrt{2} \text{ kg ms}^{-1}$$

$$\therefore |\vec{p}_i| = 50 \times 10^{-3} \times \sqrt{2} \text{ kg ms}^{-1}$$

Momentum of wall (when ball rebounds from the wall)

$$\vec{p}_f = -50 \times 10^{-3} \times \sqrt{2} \text{ kg ms}^{-1}$$

$$\therefore |\vec{p}_f| = 50 \times 10^{-3} \times \sqrt{2} \text{ kg ms}^{-1}$$

\therefore Change in the magnitude of the momentum of the wall $= |\vec{p}_f| - |\vec{p}_i| = 0$

23. $m_0 = 40 \text{ kg}$

$$\begin{aligned} m &= (40 + 160) \text{ kg} \\ &= 200 \text{ kg} \end{aligned}$$

$$v_i = 2 \text{ km/s} = 2 \times 10^3 \text{ kg}^{-1}$$

Rate of consumption of fuel = 4 kgs^{-1}

\therefore Time (t) required to completely burnt out of the fuel $= \frac{160 \text{ kg}}{4 \text{ kgs}^{-1}} = 40 \text{ s}$.

Ultimate vertical speed gained by the rocket

$$\begin{aligned} &= -gt + v_i \ln \frac{m}{m_0} \\ &= -10 \times 40 + 2 \times 10^3 \times \ln \frac{200}{40} \\ &= -400 + 3218 = 2818 \text{ m/s} \\ &= 2.82 \text{ kms}^{-1} \end{aligned}$$

24. When y length of rope has fallen on table top

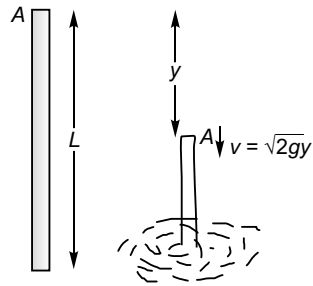

$$\begin{aligned} F_{th} &= v_{rel} \frac{dm}{dt} \\ &= v \frac{dm}{dy} \cdot \frac{dy}{dt} \\ &= v^2 \frac{dm}{dy} = v^2 \frac{M}{L} \end{aligned}$$

$$W = \frac{M}{L} g$$

$$F_{net} = W + F_{th}$$

$$\begin{aligned}\therefore F_{\text{net}} &= \frac{M}{L} yg + v^2 \frac{M}{L} \\ &= \frac{M}{L} yg + 2gy \frac{M}{L} \\ &= 3 \frac{M}{L} yg\end{aligned}$$

= Weight due to $3y$ length of the rope.

25. Horizontal velocity of incoming sand

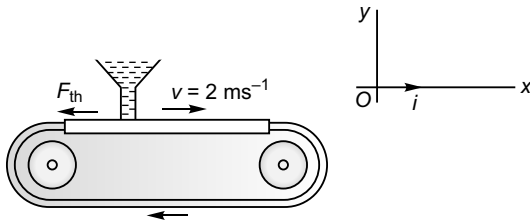

$$\vec{v} = \vec{0}$$

Horizontal velocity of the conveyer belt

$$= (\vec{v}) \text{ (say)} = v \hat{i}$$

$$\begin{aligned}\therefore \vec{u}_{\text{rel}} &= \vec{v}_1 - \vec{v}_2 \\ &= \vec{0} - (v \hat{i}) \\ &= -v \hat{i}\end{aligned}$$

$$\begin{aligned}\therefore F_{\text{th}} &= \vec{v}_{\text{rel}} \frac{dm}{dt} \\ &= - \left(v \cdot \frac{dm}{dt} \right) \hat{i}\end{aligned}$$

As $\frac{dm}{dt} > 0$, the falling sand particles exert thrust force which decelerates the conveyer belt.

Force required to keep the belt moving

$$\begin{aligned}\vec{F} &= -\vec{F}_{\text{th}} \\ &= v \frac{dm}{dt} \hat{i} \\ &= (2\text{ms}^{-1} \times 5\text{kgs}^{-1}) \hat{i} \\ &= 10\text{N} \hat{i}\end{aligned}$$

Power delivered by motor to drive belt at 2 m/s

$$\begin{aligned}&= |\vec{F}| |\vec{v}| = 10\text{N} \times 2\text{ms}^{-1} \\ &= 20\text{W}\end{aligned}$$

$$\begin{aligned}26. \quad ma &= F_{\text{th}} - mg \\ \text{or} \quad ma &= F_{\text{th}} \\ &\text{(neglecting } mg \text{ as compare to } F_{\text{th}})\end{aligned}$$

$$\text{or} \quad ma = u \left(-\frac{dm}{dt} \right)$$

$$\text{or} \quad \frac{dm}{m} = -\frac{a}{u} dt$$

$$\text{or} \quad \int \frac{dm}{m} = \int -\frac{a}{u} dt$$

$$\text{or} \quad \log_e m = -\frac{a}{u} t + K$$

Now, as $t = 0$, $m = m_0$ (given)

$$\log_e m_0 = K$$

$$\text{Thus,} \quad \log_e m = -\frac{a}{u} t + \log_e m_0$$

$$\text{or} \quad \log_e \frac{m}{m_0} = -\frac{a}{u} t$$

$$\text{or} \quad m = m_0 e^{-\frac{a}{u} t}$$

$$27. \quad u = 100\text{ms}^{-1}, v = 0\text{ms}^{-1}, s = 6\text{cm}$$

$$v^2 = u^2 + 2as$$

$$\Rightarrow \quad a = -\frac{u^2}{2s}$$

(a) Now, $v = u + at$

$$\begin{aligned}\therefore \quad t &= -\frac{u}{a} = -\frac{u}{-\frac{u^2}{2s}} = \frac{2s}{u} \\ &= \frac{2 \times 6 \times 10^{-2}}{100} = 1.2\text{ms}\end{aligned}$$

(b) Impulse on log = - Change in momentum of bullet

$$\begin{aligned}&= -m(0 - u) \\ &= mu \\ &= 5 \times 10^{-3} \times 100 \\ &= 0.5\text{Ns}\end{aligned}$$

(c) Average force experienced by the log

$$\begin{aligned}&= \frac{\text{Impulse}}{\text{time}} = \frac{0.5}{1.2 \times 10^{-3}} \\ &= 416.67\text{N}\end{aligned}$$

28. Let us consider right direction as positive.

Impulse of the spring on the block

$$\begin{aligned}&= \text{Change in momentum of block} \\ &= m(v - u)\end{aligned}$$

$$\begin{aligned}
 &= 3[(+40) - (-50)] \\
 &= +270 \text{ Ns} \\
 &= 270 \text{ Ns} \quad \text{(to the right)}
 \end{aligned}$$

$$\text{Average force on block} = \frac{\text{Impulse}}{\Delta t}$$

$$\begin{aligned}
 &= \frac{270}{0.02} \\
 &= 13500 \text{ N} \\
 &= 13.5 \text{ kN} \quad \text{(to the right)}
 \end{aligned}$$

29. $\vec{p} = m \vec{v} = 2(2t \hat{i} - 4 \hat{j})$

$$\therefore \frac{d\vec{p}}{dt} = 4 \hat{i}$$

or $d\vec{I} = 4 \hat{i} dt$ (where, \vec{I} = Impulse)

or $\int d\vec{I} = \int_0^2 4 \hat{i} dt$

$$\begin{aligned}
 \text{or} \quad \vec{I} &= 4 \hat{i}(2 - 0) \\
 &= 8 \hat{i} \text{ kg}\cdot\text{ms}^{-1}
 \end{aligned}$$

30. $m \Delta v = F \Delta t$

or $m \Delta v = \text{Area under } F\text{-}t \text{ graph}$

or $m \Delta v = \frac{16 + 8}{2} \times 20000$

or $m \Delta v = 240000$

$$\therefore \Delta v = \frac{240000}{1200} = 200 \text{ m/s}$$

$$v - u = 200$$

$$\therefore v = 200 \text{ ms}^{-1} \text{ as } u = 0$$

31. $v_1 = v_2' = -2 \text{ ms}^{-1}$

$$v_2 = v_1' = +3 \text{ ms}^{-1}$$

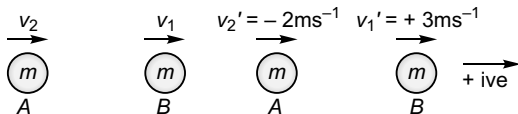

(When two bodies of equal masses collide elastically they interchange their velocities)

32. $m_1 = 1 \text{ kg}$ and $m_2 = 1 \text{ kg}$ (given)

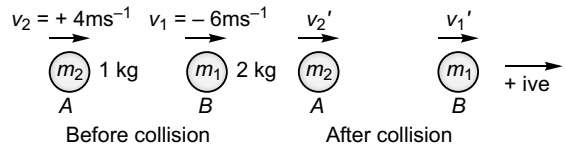

$$v_1' = \left(\frac{m_1 - m_2}{m_1 + m_2} \right) v_1 + \left(\frac{2m_2}{m_1 + m_2} \right) v_2$$

$$= \left(\frac{2 - 1}{2 + 1} \right) (-6) + \left(\frac{2 \times 1}{2 + 1} \right) (4)$$

$$= -2 + \frac{8}{3}$$

$$= +\frac{2}{3} \text{ ms}^{-1}$$

$$= \frac{2}{3} \text{ ms}^{-1} \text{ (in + ive } x \text{ direction)}$$

$$v_2' = \left(\frac{m_2 - m_1}{m_1 + m_2} \right) v_2 + \left(\frac{2m_1}{m_1 + m_2} \right) v_1$$

$$= \left(\frac{1 - 2}{2 + 1} \right) (4) + \left(\frac{2 \times 2}{2 + 1} \right) (-6)$$

$$= -\frac{4}{3} - 8$$

$$= -\frac{28}{3} \text{ ms}^{-1} = \frac{28}{3} \text{ ms}^{-1}$$

(in - ive x direction).

33. $v_1' = \frac{1+e}{2} v_2$ and $v_2' = \frac{1-e}{2} v_2$

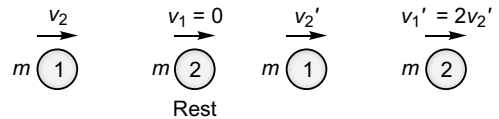

$$\Rightarrow \frac{v_1'}{v_2'} = \frac{1+e}{1-e}$$

or $2 = \frac{1+e}{1-e}$ ($\because v_1' = 2v_2'$)

or $2 - 2e = 1 + e$

or $e = \frac{1}{3}$

34. $mv = mv_1 + mv_2$

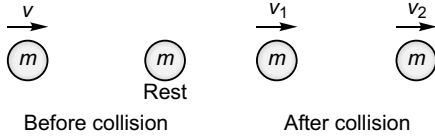

\Rightarrow

$$v = v_1 + v_2$$

Also,
$$\frac{\frac{1}{2}mv_1^2 + \frac{1}{2}mv_2^2}{\frac{1}{2}mv^2} = \frac{3}{4}$$

or
$$(v_1^2 + v_2^2) = \frac{3}{4}v^2 \quad \dots(i)$$

or
$$(v_1 + v_2)^2 - 2v_1v_2 = \frac{3}{4}v^2$$

or
$$v^2 - 2v_1v_2 = \frac{3}{4}v^2$$

or
$$2v_1v_2 = \frac{1}{4}v^2$$

$$e = \frac{\text{Velocity of separation}}{\text{Velocity of approach}}$$

or
$$e = \frac{v_2 - v_1}{v - 0}$$

$$e = \frac{v_2 - v_1}{v}$$

$$e^2 = \left(\frac{v_2 - v_1}{v}\right)^2$$

or
$$e^2 = \frac{v_2^2 + v_1^2 - 2v_1v_2}{v^2}$$

or
$$e^2 = \frac{(v_1 + v_2)^2 - 4v_1v_2}{v^2}$$

or
$$e^2 = \frac{v^2 - \frac{v^2}{2}}{v^2}$$

or
$$e^2 = \frac{1}{2}$$

or
$$e = \frac{1}{\sqrt{2}}$$

35.
$$v_1' = \left(\frac{2m_2}{m_1 + m_2}\right)v_2$$

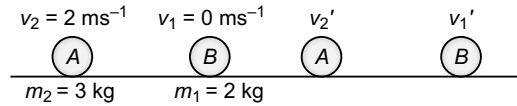

$$= \frac{2 \times 3}{2 + 3} \times 2$$

$$= \frac{12}{5} = 2.4 \text{ ms}^{-1}$$

and
$$v_2' = \left(\frac{m_2 - m_1}{m_1 + m_2}\right)v_2$$

$$= \frac{3 - 2}{2 + 3} \times 2$$

$$= \frac{2}{5} = 0.4 \text{ ms}^{-1}$$

Distance between blocks when they stop sliding

$$= \frac{v_1'^2}{2\mu_k g} - \frac{v_2'^2}{2\mu_k g}$$

$$= \frac{1}{2\mu_k g} (v_1'^2 - v_2'^2)$$

$$= \frac{1}{2 \times 0.3 \times 10} [(2.4)^2 - (0.4)^2]$$

$$= \frac{2.8}{3} = 0.933 \text{ m}$$

Objective Questions (Level 1)

Single Correct Option

- Momentum remains conserved. Decrease in momentum of the ball is transferred to sand while KE does not remain conserved as it gets used up in doing work against friction.
- $F_{\text{ext}}^{\text{net}} = M \times a_{\text{CM}}$
 \therefore If $F_{\text{ext}}^{\text{net}} = 0$, $a_{\text{CM}} = 0$
i.e., $\frac{d}{dt} v_{\text{CM}} = 0$
 or $v_{\text{CM}} = \text{constant}$
 Option (a) is correct.
- The forces acting on the blocks would be equal and opposite as per Newton's 3rd law of motion. Acceleration of the blocks will depend upon their masses as per Newton's 2nd law of motion. Accelerations being different velocities will be unequal.



- Option (c) is correct.
- While colliding the balls will apply equal and opposite impulsive force on each other. Impulsive forces will change the momentum of the balls but the total momentum of the system of 2 balls will remain conserved impulsive forces being internal ones. Change in momentum of the system will definitely be due to external gravitational forces on the balls but as the time of impact shall be very less the impulsive force will over shadow the weak gravitational force.
 - External force acting on the cannon shell before explosion is the gravitational force. Now, as no extra net external force would be act on the shell during collision the momentum of the system shall remain conserved and the CM of the system (now broken in pieces) will also keep on following the path which the shell would have followed had the explosion not taken place. Further, as the explosion would never be super-elastic, the KE of the system can't increase after explosion.
 Option (d) is correct.

6. $\frac{\text{Velocity of separation}}{\text{Velocity of approach}} = e$

As in an elastic collision $e < 1$

Velocity of separation < velocity of

approach

(when $e = 0$, the velocity of separation is zero and the colliding bodies do not separate from each other.)

Further, whether the collision is elastic or inelastic the law of conservation of momentum always hold good.

\therefore Option (d) is correct.

7. $\vec{p} = M \vec{v}_{\text{CM}}$, Option (a) is correct.

$\vec{p} = \vec{p}_1 + \vec{p}_2 + \vec{p}_3 + \dots$

Option (b) is correct.

Further, we define momentum for every type of motion.

\therefore Option (d) is correct.

- Let us consider a system of two masses as shown in figure.

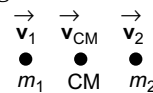

Momentum of system about CM

$$\begin{aligned}
 &= m_1(\vec{v}_1 - \vec{v}_{\text{CM}}) + m_2(\vec{v}_2 - \vec{v}_{\text{CM}}) \\
 &= m_1 \vec{v}_1 + m_2 \vec{v}_2 - (m_1 + m_2) \vec{v}_{\text{CM}} \\
 &= (m_1 + m_2) \vec{v}_{\text{CM}} - (m_1 + m_2) \vec{v}_{\text{CM}} \\
 &= \vec{0}
 \end{aligned}$$

Option (c) is correct.

- Option (a) If collision is inelastic.

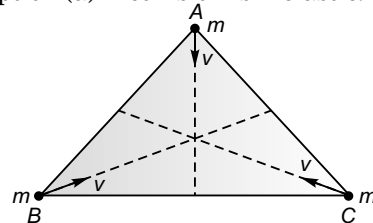

- Option (b) If collision is perfectly inelastic
 Option (c) If the dimensions of the particles $\rightarrow 0$

\therefore Option (d) would be the answer.

10. $F \Delta t = m \Delta v$
 $\Rightarrow F = \frac{m \Delta v}{\Delta t}$
 $= \frac{5 \times (65 - 15)}{2}$
 $= 125 \text{ N}$

11. $m_c \times d_1 = m_o \times (d - d_1)$

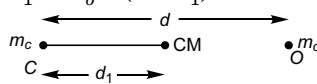

$\Rightarrow d_1 = \frac{m_o}{m_o + m_c} d$
 $= \frac{8}{8 + 6} d$
 $= \frac{4}{7} d$
 $= \frac{4}{7} \times (1.2 \times 10^{-10} \text{ m})$
 $= 0.64 \times 10^{-10} \text{ m}$

12. $M \times 0 = mv + (M - m) V$

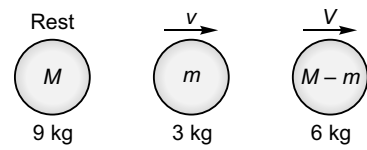

$\Rightarrow V = -\frac{m}{(m - M)} v$
 $= -\frac{3}{9 - 3} \times 16$
 $= -8 \text{ ms}^{-1}$
 $\therefore \text{KE of 6 kg mass} = \frac{1}{2} \times 6 \times (-8)^2$
 $= 192 \text{ J}$

13. $v_1' = \frac{2m_2}{m_1 + m_2} v_2$

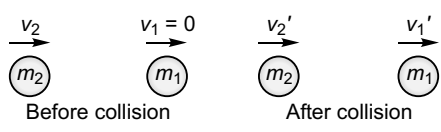

$= 2v_2 \quad (\text{as } m_1 < m_2)$

Option (b) is correct.

14. Horizontal velocity of the leaving coal :

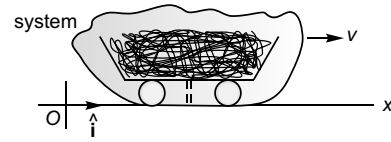

$$\vec{v}_1 = +v \hat{i}$$

Horizontal velocity of the system

$$\vec{v}_2 = +v \hat{i}$$

$$\therefore \vec{U}_{\text{rel}} = \vec{v}_1 - \vec{v}_2 = \vec{0}_1$$

$$\therefore \vec{F}_{\text{th}} = \vec{U}_{\text{rel}} \frac{dm}{dt} = \vec{0}$$

As, the leaving coal does not exert any thrust force on the wagon, the speed of the wagon won't change.

Option (a) is correct.

15. If n be the number of bullet shots per second

$$n \times [\text{change in momentum per second}] \leq F$$

$$\text{i.e., } n \left[\frac{40}{100} \times (1200 - 0) \right] \leq 144$$

$$\text{or } n \leq \frac{144}{48} \quad \text{or } n \leq 3$$

\therefore Option (a) is correct.

16. Change in momentum along x -axis

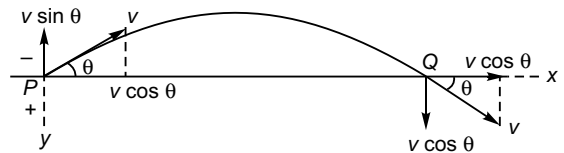

$$= m (v \cos \theta - v \cos \theta) = 0$$

\therefore Net change in momentum

= Change in momentum along y -axis

$$= m[(+v \sin \theta) - (-v \sin \theta)]$$

$$= 2mv \sin \theta$$

$$= mv\sqrt{2} \quad (\text{as } \theta = 45^\circ)$$

Option (a) is correct.

17. Velocity of ball before first impact *i.e.*, when it reaches point Q of the horizontal plane

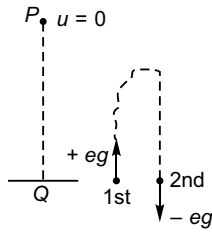

$$v = 0 + (g) \cdot 1 = g$$

∴ Velocity of ball after 1st impact
 $= ev = eg$

time elapsed between 1st and 2nd impact with the horizontal plane

$$(+eg) = (+eg) + (-g)t$$

$$\Rightarrow t = 2e = \frac{4}{3} \text{ s} \quad (\text{as, } e = \frac{2}{3} L)$$

Option (c) is correct.

18. $x_{CM} = \frac{\int x dm}{\int dm} = \frac{\int x m dx}{\int m dx}$

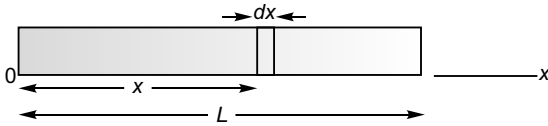

(where m = mass per unit length)

$$\begin{aligned} &= \frac{\int x \frac{Ax^2}{L} dx}{\int \frac{Ax^2}{L} dx} \quad \left(\because m = \frac{Ax^2}{L} \right) \\ &= \frac{\int_0^L x^3 dx}{\int_0^L x^2 dx} \\ &= \frac{\frac{L^4}{4} \times \frac{3}{L^3}}{\frac{3}{4} L} \\ &= \frac{3}{4} L \end{aligned}$$

Option (a) is correct.

19. As there is no net external force acting on the system in the horizontal direction, the CM of the system shall not shift along x-axis.

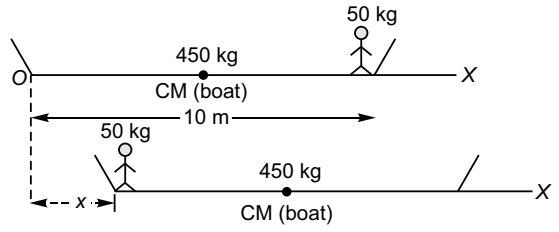

$$\therefore \frac{50 \times 10 + 450 \times 5}{50 + 450} = \frac{50 \times (x) + 450 \times (x + 5)}{50 + 450}$$

(Initially) (Finally)

$$\Rightarrow x = 1 \text{ m}$$

Option (b) is correct.

20. As discussed in the answer to previous question no. 19.

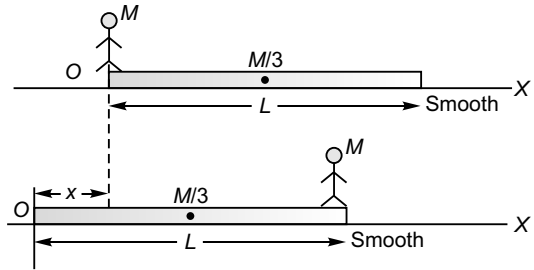

$$\frac{Mx + \frac{M}{3} \left(x + \frac{L}{2} \right)}{M + \frac{M}{3}} = \frac{ML + \frac{M}{3} \left(\frac{L}{2} \right)}{M + \frac{M}{3}}$$

$$\Rightarrow x \left[M + \frac{M}{3} \right] = ML$$

$$x = \frac{3}{4} L$$

i.e., the distance that plank moves = $\frac{3}{4} L$

∴ The distance that the man moves

$$\begin{aligned} &= L - \frac{3}{4} L \\ &= \frac{L}{4} \end{aligned}$$

Option (b) is correct.

21.

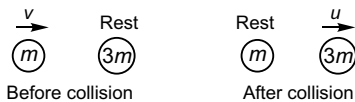

$$mv + 3m \cdot 0 = m \cdot 0 + 3mu$$

$$\begin{aligned} \therefore u &= \frac{v}{3} \\ e &= \frac{\text{Velocity of separation}}{\text{Velocity of approach}} \\ &= \frac{u - 0}{v - 0} = \frac{u}{v} \\ &= \frac{1}{3} \end{aligned}$$

Option (d) is correct.

22. Change in momentum of A or B = mu

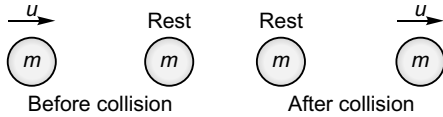

(As collision is elastic)

Impulse = Change in momentum

$$\frac{Ft_0}{2} = mu$$

$$\Rightarrow F = \frac{2mu}{t_0}$$

Option (b) is correct.

23. Acceleration of block A



$$a_0 = \frac{F'}{m}$$

$$\Rightarrow F' = ma_0$$

Acceleration of block B:

$$\begin{aligned} a_B &= \frac{F - F'}{m} \\ &= \frac{F - ma_0}{m} = \frac{F}{m} - a_0 \end{aligned}$$

- 24.

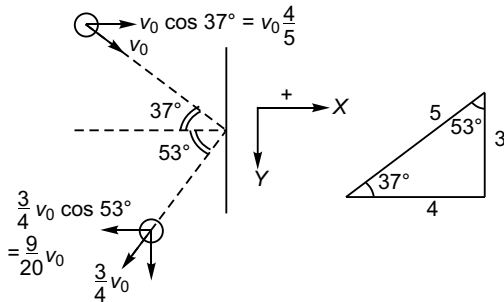

Option (c) is correct.

Impulse on ball

= Change in momentum of ball

$$\begin{aligned} &= \left(-\frac{9}{20}mv_0\right) - \left(+\frac{4}{5}mv_0\right) \\ &= -\frac{5}{4}mv_0 \end{aligned}$$

25. If a ball dropped from height h rebounds to a height h' , then speed of ball just before 1st impact, $u = \sqrt{2gh}$

Just after 1st impact $u' = \sqrt{2gh'}$

$$\begin{aligned} \therefore e &= \frac{u'}{u} = \sqrt{\frac{h'}{h}} = \sqrt{\frac{64}{100}} \\ &= 0.8 \end{aligned}$$

$$\text{i.e., } h' = e^2h$$

Height attained after n th impact

$$= e^{2n}h$$

$$= (0.8)^{2n} \cdot 1 \quad (\text{as } h = 1 \text{ m})$$

$$= (0.8)^{2n}$$

Option (d) is correct.

26. Momentum of car (+ block) before throwing block

= Momentum of car after throwing block + Momentum of block

$$500 \times 1 \hat{\mathbf{i}} = (500 - 25) \vec{\mathbf{v}} + 25(20 \hat{\mathbf{k}})$$

$$\text{or } 475 \vec{\mathbf{v}} = 500(\hat{\mathbf{i}} - \hat{\mathbf{k}})$$

$$\text{or } \vec{\mathbf{v}} = \frac{20}{19} (\hat{\mathbf{i}} - \hat{\mathbf{k}})$$

Option (c) is correct.

27. While force is increasing with time

$$F = kt \quad (\text{where } k \text{ is +ive constant})$$

$$\text{or } ma = kt$$

$$\text{or } \frac{dv}{dt} = \frac{k}{m}t$$

$$\therefore v = \frac{k}{m} \frac{t^2}{2} + C$$

$$\text{or } v = \frac{k}{m} \cdot \frac{t^2}{2}$$

(If at $t = 0, v = 0$)

Thus, graph between v and t would be

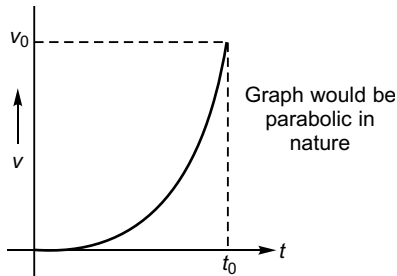

While force is decreasing with time.

$$F = -kt \text{ (where } k \text{ is +ive constant)}$$

$$\Rightarrow v = -\frac{k}{m} \frac{t^2}{2} + C'$$

$$\text{At } t = 0, v = v_0$$

$$\therefore C' = v_0 + \frac{k}{m} \frac{t_0^2}{2}$$

$$\text{Thus, } v = v_0 + \frac{k}{2m} (t_0^2 - t^2)$$

Thus, graph between v and t would be

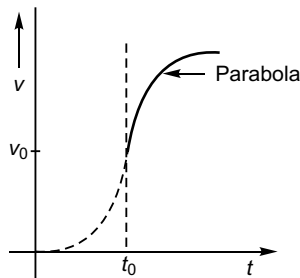

\therefore Option (a) is correct.

$$28. x_{CM} = \frac{A_1 x_1 + A_2 x_2}{A_1 + A_2}$$

$$0 = \frac{[\pi(3R)^2 - \pi R^2]x_1 + [-\pi R^2]2R}{\pi(3R)^2 - \pi R^2}$$

$$\text{or } 8\pi R^2 x_1 = 2\pi R^2 R \text{ or } 8x_1 = 2R$$

$$\text{or } x_1 = \frac{R}{4}$$

Option (c) is correct.

$$29. x_{CM} = \frac{A_1 x_1 + A_2 x_2 + A_3 x_3}{A_1 + A_2 + A_3}$$

$$\therefore 0 = [\pi(4R)^2 - \pi R^2 - \pi R^2]x_1 + [-\pi R^2]3R + [-\pi R^2] \cdot 0$$

$$\text{or } 14x_1 = 3R$$

$$\text{or } x_1 = \frac{3}{14}R$$

Option (d) is correct.

30. As no external force is acting along the horizontal direction on the system (wedge + block). The CM of the system shall not change along horizontal when the block moves over the wedge but would change along vertical as net force (= gravitational force) is acting on the block.

Further, as no non-conservative force is acting on the system, its total energy will not change.

Option (d) is correct.

31.

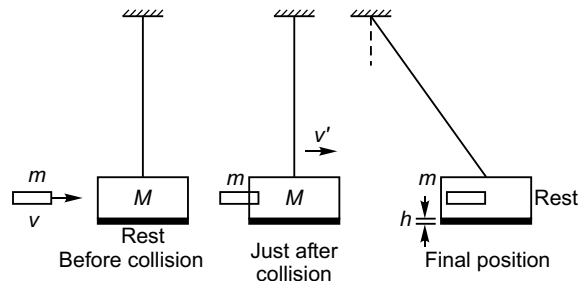

$$mv = (M + m)v' \quad \dots(i)$$

From final position, $v' = \sqrt{2gh}$

From Eq. (i),

$$\text{or } \frac{m}{M + m}v = \sqrt{2gh}$$

$$\text{or } v = \left(1 + \frac{M}{m}\right)\sqrt{2gh}$$

Option (c) is correct.

32. As no net extra external force is acting on the system the CM of the gun and the bullet system remains at rest. The force exerted by the trigger of the gun on the bullet is an internal one.

$$33. m_1 g - T = m_1 a$$

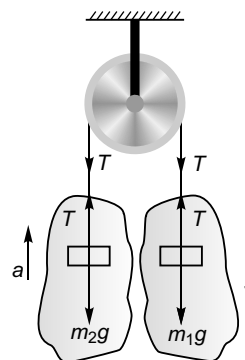

$$T - m_2g = m_2a$$

$$\therefore (m_1 - m_2)g = (m_1 + m_2)a$$

or

$$a = \frac{m_1 - m_2}{m_1 + m_2}g$$

$$a_{CM} = \frac{m_1a + m_2(-a)}{m_1 + m_2}$$

$$= \frac{m_1 - m_2}{m_1 + m_2}a$$

$$= \left(\frac{m_1 - m_2}{m_1 + m_2}\right)^2 g$$

Option (b) is correct.

34. $v = u - gt + v_i \ln \frac{m_0}{m}$

or

$$v = u + v_2 \ln \frac{m_0}{m}$$

(neglecting gravity as given)

or

$$v = v_2 \ln \frac{m_0}{m} \quad (\text{Taking } u = 0)$$

or

$$v = v \ln \frac{m_0}{m} \quad (\text{as } v_i = v)$$

\therefore

$$\log_e \frac{m_0}{m} = 1$$

\Rightarrow

$$\frac{m_0}{m} = e^1 = 2.718$$

Option (a) is correct.

35. Velocity of water after striking the plate would be almost zero as then it flows parallel to the plate.

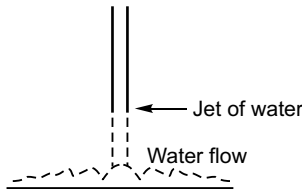

Force exerted on plate

= - [Rate of change of momentum of water]

$$= - \left[\frac{m \cdot 0 - mu}{t} \right]$$

$$= \frac{mu}{t} = \frac{m}{t} \cdot u$$

$$= 0.5 \frac{\text{kg}}{\text{s}} \times 1 \text{ms}^{-1}$$

$$= 0.5 \text{ N}$$

Option (c) is correct.

36. Velocity of separation would be zero as the collision is completely inelastic.

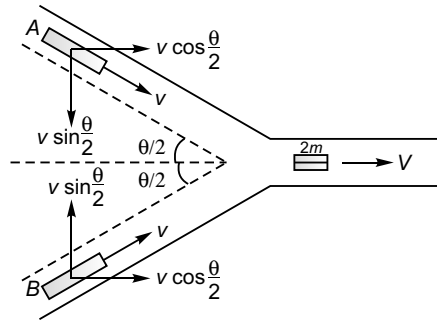

Velocity of approach = Velocity of A w.r.t.

B or velocity of B w.r.t. A

$$= \left(+v \sin \frac{\theta}{2} \right) - \left(-v \sin \frac{\theta}{2} \right)$$

$$= 2v \sin \frac{\theta}{2}$$

Common velocity (V) after collision

$$mv \cos \frac{\theta}{2} + mv \cos \frac{\theta}{2} = 2mV$$

\therefore

$$V = v \cos \frac{\theta}{2}$$

Option (d) is correct.

37. $v \sin 53^\circ = u \sin 37^\circ$

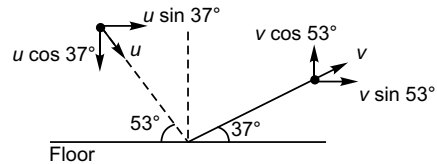

$$v \times \frac{4}{5} = u \times \frac{3}{5}$$

i.e.,

$$v = \frac{3}{4}u$$

Impulse exerted on floor

= - [Change in momentum of ball]

= - [(-mv cos 53°) - (+mu cos 37°)]

= m [v cos 53° + u cos 37°]

$$= m \left[\frac{3}{4}u \times \frac{3}{5} + u \times \frac{4}{5} \right]$$

$$= \frac{5}{4}mu$$

$$= \frac{5}{4} \times 1 \times 5 = 6.25 \text{ Ns}$$

38. As the CM will not change along x -axis, for no net force acting on system (wedge + block) along x -axis.

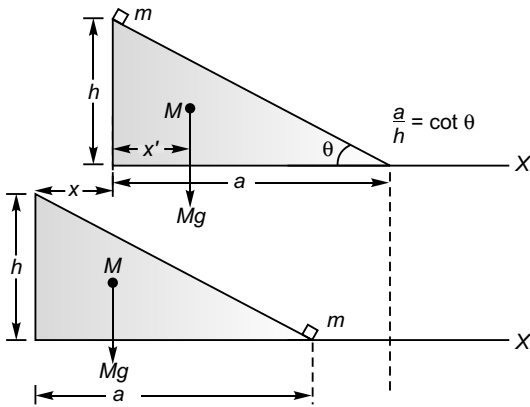

$$mx + M(x + x') = Ma + Mx'$$

$$\therefore mx + Mx = ma \text{ or } x = \frac{m}{M + m} a$$

$$= \frac{m h \cot \theta}{M + m}$$

Option (b) is correct.

39. $x_{CM} = \frac{2(4M) + 3(-M) + 3(+M)}{4M + (-M) + (+M)} = 2 \text{ cm}$

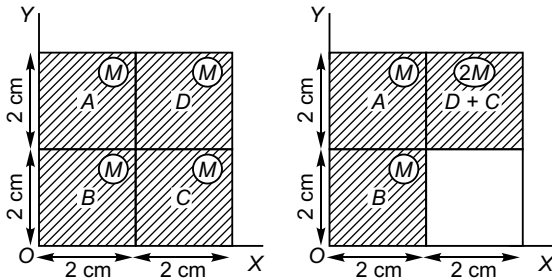

$$y_{CM} = \frac{2(4M) + 1(-M) + 3(+M)}{4M + (-M) + (+M)} = 2.5 \text{ cms}$$

Option (c) is correct.

40. As explained in the answer to question no. 20 and 19.

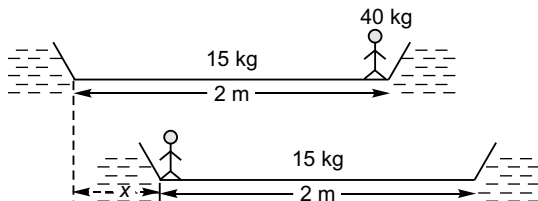

x = Displacement of boat

$$x \cdot 40 + (1 + x) 15 = 2 \times 40 + 1 \times 15$$

i.e., $x = 1.46 \text{ m}$

(The frictional forces on the boat by the boy and that by the boy on the boat are internal forces).

41.
$$\vec{v} = \frac{m \vec{v}_1 + m \vec{v}_2 + m \vec{v}_3}{m + m + m}$$

$$= \frac{1}{3} [\vec{v}_1 + \vec{v}_2 + \vec{v}_3]$$

$$= \frac{1}{3} [v_0 \hat{i} + (-3v_0 \hat{j}) + (5v_0 \hat{k})]$$

$$= \frac{v_0}{3} [\hat{i} - 3 \hat{j} + 5 \hat{k}]$$

Option (d) is correct.

42. The shell explodes at A, the highest point. As piece of mass $\frac{M}{5}$ falls very close to mortar, its velocity after explosion must be $-u$.

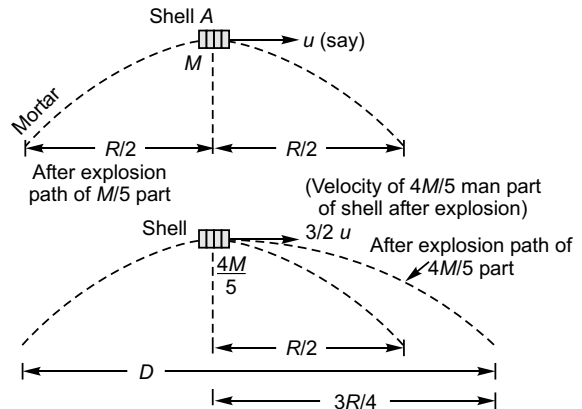

Thus, $Mu = \frac{M}{5}(-u) + \frac{4M}{5}(v)$

i.e., $v = \frac{3}{2}u$

As the velocity has increased $\frac{3}{2}$ times the range of this part will be

$$\frac{3}{2} \text{ of } \frac{R}{2} \text{ i.e., } \frac{3R}{4}$$

$\therefore D = \frac{R}{2} + \frac{3R}{4} = \frac{5R}{4}$

Option (c) is correct.

43.
$$v_2' = \frac{m_2 - m_1}{m_2 + m_1} v_2$$

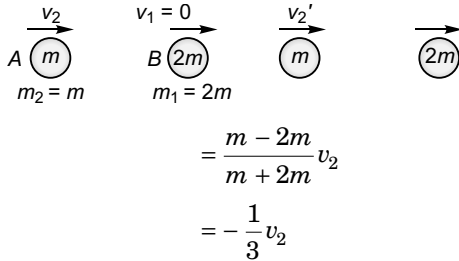

$$= \frac{\frac{1}{2} m v_2^2 - \left[\frac{1}{2} m \left(-\frac{1}{3} v_2 \right)^2 \right]}{\frac{1}{2} m v_2^2}$$

$$= \frac{\frac{1}{2} - \frac{1}{18}}{\frac{1}{2}}$$

$$= \frac{8}{9}$$

Fraction of KE lost by colliding particle A

$$= \frac{\text{KE lost}}{\text{Initial KE}}$$

JEE Corner

Assertion and Reason

1. To answer this question, let us find the centre of mass of an L -shaped rigid body (as shown in figure) of uniform thickness.

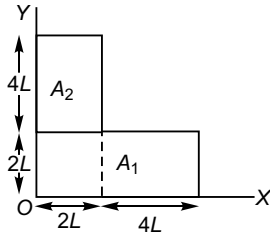

$$x_{\text{CM}} = \frac{A_1 x_1 + A_2 x_2}{A_1 + A_2}$$

$$= \frac{(6L \times 2L) 3L + (4L \times 2L) L}{(6L \times 2L) + (4L \times 2L)}$$

$$= \frac{36L^3 + 8L^3}{12L^2 + 8L^2}$$

$$= \frac{44L^3}{20L^2}$$

$$= 2.2L$$

Similarly $y_{\text{CM}} = 2.2L$

Thus, we see that CM is lying outside.

Centre of mass of the rigid body of uniform thickness as shown in figure would be at point P which is neither outside nor inside.

The centre of mass of a uniform plate lies at its centre. The CM of a uniform sphere is at its centre.

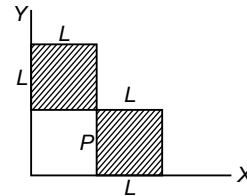

These examples show that assertion is false.

It is correct that centre of mass and centre of gravity of a body coincide if the body is placed in a uniform gravitational field.

Option (d) is correct.

2. $a_1 = \frac{F_1}{m}$, $a_2 = \frac{F - F_1}{2m}$

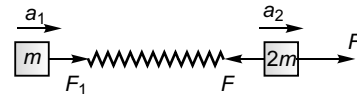

$$\therefore a_{\text{CM}} = \frac{m a_1 + 2m a_2}{m + 2m}$$

$$= \frac{F_1 + (F - F_1)}{3m}$$

$$= \frac{F}{3m}$$

As F is constant, the value of a_{CM} will remain constant (Reason).

As CM is accelerated the velocity of CM will obviously increase (Assertion).

Option (a) is correct.

3. As per assertion if force is applied on a system the linear momentum of the system must not remain conserved. But, it will not be true if we apply two equal and opposite external forces on the system as then net external force on the system will be zero and the linear momentum will remain conserved as given under Reason which is correct.

Option (d) is correct.

4. A rocket moves forward due to the thrust force produced on it as per Newton's 3rd law of motion (as given under Reason) when gas inside (not the surrounding air as given under assertion) it is pushed backwards.

Option (d) is correct.

5. Linear momentum of a system remains conserved when no net external force acts on the system *i.e.*, only a net external force on a system can change its linear momentum. Inside a system internal forces are always in pairs and as such can't change linear momentum.

If two blocks connected by a spring placed on a smooth surface are stretched apart the internal restoring forces acting on blocks will definitely increase the KE of the system but this argument under Reason has nothing to do with the nothing under Assertion that internal forces can't change linear momentum.

Option (b) is correct.

6. $KE = \frac{p^2}{2m}$

i.e., $KE \propto \frac{1}{m}$ (if momentum p is constant).

\therefore Nothing under reason is correct.

When bullet is fired and comes out of the gun.

Linear momentum of gun

$$= \text{Linear momentum of bullet} = p$$

(In magnitude)

$$\therefore \frac{(\text{KE})_{\text{gun}}}{(\text{KE})_{\text{bullet}}} = \frac{\text{Mass of bullet}}{\text{Mass of gun}}$$

(as given under Reason)

This is what is given in Assertion.

Thus, both **Assertion and Reason** are true and also reason is the correct explanation of the assertion.

Option (a) is correct.

7. As no net external force is acting there on the system along horizontal direction the momentum of the system remains conserved along horizontal direction but as gravitational force (a net external force) acts on block in the vertical direction (downwards) the momentum of the system does not remain constant along vertical direction. As overall momentum of the system does not remain constant, **Assertion is true.**

As wedge is at rest, **Reason is false.**

Option (c) is correct.

8. In any collision, there is not change in the momentum of the system as given in **reason**, which is **true.**

$$\therefore \Delta \vec{p}_1 + \Delta \vec{p}_2 = \vec{0}$$

i.e., $\Delta \vec{p}_1 = -\Delta \vec{p}_2 \quad \dots(i)$

\therefore **Assertion is false.**

Option (d) is correct.

9. **Reason is true** as explained in the answer to question no. 6 and also in Eq. (i) in the answer to question no. 8.

As KE is inversely proportional to mass, the KE of the block of mass $2m$ will be $\frac{K}{2}$

when the KE of the block of mass m is K .

\therefore **Assertion is true.**

Further, as Reason is the correct explanation of the Assertion. Option would be (a).

10. **Assertion is false** as for example heat energy can be given to a system without any increase in momentum of the system while KE given to a system increases its momentum.

$\left(KE = \frac{p^2}{2m}\right)$ as given is Reason which is true.

Option (d) is correct.

11. As no external force would be acting on the system of electron and proton along the line joining electron and proton the CM of electron and proton will remain at rest. Therefore, **Assertion is false**.

Further, as proton is heavier than electron **the reason is true**.

Option (d) is correct.

12. $v_1' = \frac{m_1 - m_2}{m_1 + m_2} v_1 + \frac{2m_2}{m_1 + m_2} v_2$

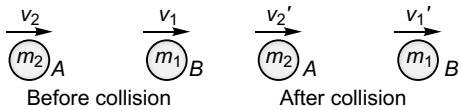

and $v_2' = \frac{m_2 - m_1}{m_1 + m_2} v_2 + \frac{2m_1}{m_1 + m_2} v_1$

$$\begin{aligned} v_2' - v_1' &= \frac{m_2 - m_1 - 2m_2}{m_1 + m_2} v_2 + \frac{2m_1 - m_1 + m_2}{m_1 + m_2} v_1 \\ &= -v_2 + v_1 \\ &= -(v_2 - v_1) \end{aligned}$$

i.e., $v'_{21} = -v_{21}$

i.e., relative velocity of A w.r.t. B after collision

= - (relative velocity of A w.r.t. B before collision)

∴ Reason is true and Assertion is false.

Option (d) is correct.

13. As explained in the answer to question no. 11, the CM of the objects will remain at rest. Therefore, assertion is false.

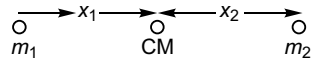

$$m_1 x_1 = m_2 x_2$$

$$\therefore \frac{x_2}{x_1} = \frac{m_1}{m_2}$$

$$\therefore x_2 > x_1 \text{ as } m_2 > m_1$$

Reason is true.

Option (d) is correct.

14. $\vec{F} = \frac{d\vec{p}}{dt}$ (Newton's second law of motion)

$$\vec{a} = \frac{\vec{F}}{m} \quad (\text{outcome of the above})$$

∴ Reason is true.

First equation tells that if same force \vec{F} is applied on different masses the rate of

change of momentum *i.e.*, $\frac{d\vec{p}}{dt}$ of each mass

will be same. Second equation tells that if same force \vec{F} is applied on different masses the \vec{a} produced in each will be different.

∴ Assertion is true.

Further, as Reason is the correct explanation of the Assertion.

Option (a) is correct.

15. **Assertion is false** as explained in the answer to question no. 12.

In every type of collision the linear momentum of the system remains conserved. Therefore, **Reason is true**.

Option (d) is correct.

Objective Questions (Level 2)

Single Correct Option

1. $m_1 v_1 + m \times 0 = m \sqrt{5gl} + m_1 \frac{v_1}{3}$

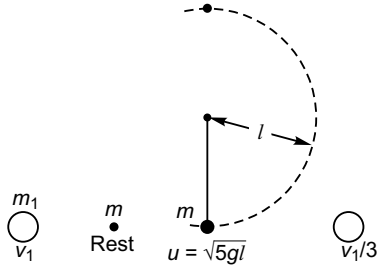

$$m_1 \cdot \frac{2v_1}{3} = m \sqrt{5gl}$$

$$\therefore v_1 = \frac{3}{2} \frac{m}{m_1} \sqrt{5gl}$$

Option (b) is correct.

2. $mu = 2mv$

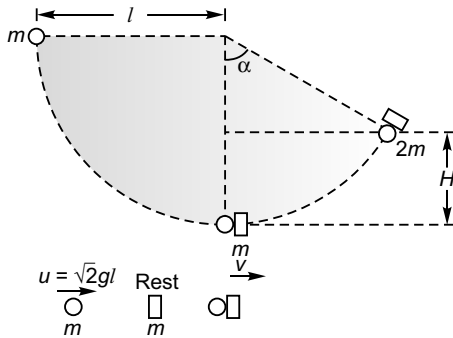

$$\Rightarrow v = \frac{u}{2}$$

$$0^2 = v^2 + 2(-g)H$$

$$\Rightarrow H = \frac{v^2}{2g}$$

$$= \frac{(u/2)^2}{2g}$$

$$= \frac{u^2}{8g}$$

or $H = \frac{2gl}{8g}$

or $l(1 - \cos \alpha) = \frac{l}{4}$

or $1 - \cos \alpha = \frac{1}{4}$

or $\alpha = \cos^{-1} \frac{3}{4}$

Option (c) is correct.

3. Here $|\vec{v}_2| = |\vec{v}_1| = v$ say

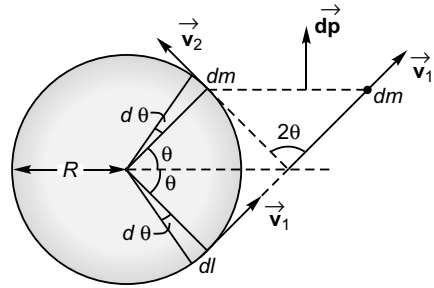

Net momentum of the two elements as shown in figure = $dp = |\vec{dp}|$

$$= 2v \, dm \sin \theta$$

$$= 2v \left(\frac{M}{\pi R} \right) (R \, d\theta) \sin \theta$$

$$= \frac{2Mv}{\pi} \sin \theta \, d\theta$$

$$p = \int_0^{\pi/2} \frac{2Mv}{\pi} \sin \theta \, d\theta$$

$$= -\frac{2Mv}{\pi} [\cos \theta]_0^{\pi/2}$$

$$= -\frac{2Mv}{\pi} [0 - 1] = \frac{2Mv}{\pi}$$

Option (b) is correct.

4. $\frac{1}{2}(2m)v^2 = \frac{1}{2}kx_0^2$

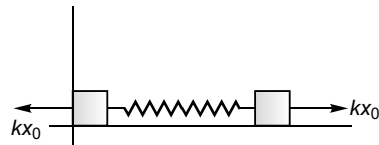

or $v = \sqrt{\frac{k}{2m}} x_0$

or $2mv = \sqrt{2mk} x_0$

or $F_{av} \times \Delta t = \sqrt{2mk} x_0$

or $F_{av} = \frac{\sqrt{2mk}}{\Delta t} x_0$

Option (b) is correct.

5. As the collisions of the striker and the walls of the carrom are perfectly elastic the striker will follow the path $OPQR$ OP ...

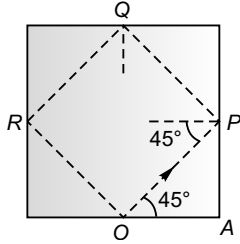

Change in KE = work done against friction

$$\frac{1}{2}mv^2 - 0 = \mu mgs$$

(m = mass of striker, s = displacement of the striker)

$$\Rightarrow s = \frac{v^2}{2\mu g} = \frac{(2)^2}{2 \times 0.2 \times 10} = 1 \text{ m}$$

$$PQ = OP = OA\sqrt{2} = \left(\frac{1}{2\sqrt{2}}\right)\sqrt{2} = \frac{1}{2} \text{ m}$$

$$OP + PQ = \frac{1}{2} + \frac{1}{2} = 1 \text{ m}$$

\therefore Striker will stop at point Q where co-ordinates are $\left(\frac{1}{2\sqrt{2}}, \frac{1}{\sqrt{2}}\right)$.

Option (a) is correct.

6. As no force is acting on the system along horizontal, the CM of the system will not shift horizontally.

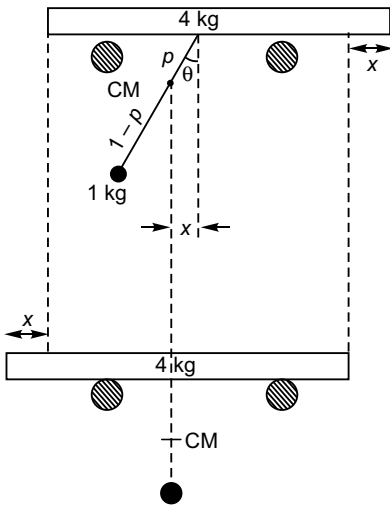

$$4p = 1(1 - p)$$

$$\Rightarrow p = \frac{1}{5} \text{ m}$$

Displacement (x) of bar when pendulum becomes vertical

$$\frac{x}{p} = \sin \theta$$

$$x = p \sin \theta = \frac{1}{5} \sin 30^\circ = \frac{1}{10} \text{ m} = 0.1 \text{ m}$$

When the ball reaches the other extreme end the bar will further shift to the left by distance x and as such the net displacement of the bar will be $2x$ i.e., 0.2 m.

Option (b) is correct.

7.

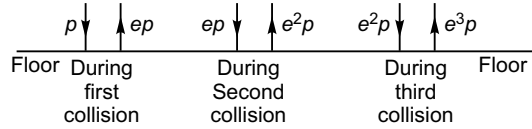

Momentum imparted to the floor in

$$\text{1st collision} = p - (-ep) = p(1 + e)$$

$$\text{2nd collision} = ep - (-e^2p) = ep(1 + e)$$

$$\text{3rd collision} = e^2p - (-e^3p) = e^2p(1 + e)$$

As theoretically there will be infinite collision, total momentum imparted to floor

$$\begin{aligned} &= p(1 + e) + ep(1 + e) + e^2p(1 + e) + \dots \infty \\ &= p(1 + e)[1 + e + e^2 + \dots \infty] \\ &= p(1 + e) \frac{1}{1 - e} = p \left(\frac{1 + e}{1 - e} \right) \end{aligned}$$

Option (d) is correct.

8. Let F be the frictional force applied by plate when bullet enters into it

$$\therefore \frac{1}{2}mu^2 = Fh \quad \dots(i)$$

If plate was free to move

$$mu + 0 = (M + m)u'$$

$$\therefore u' = \frac{m}{M + m}u$$

$$\text{New KE of bullet} = \frac{1}{2}mu^2 - \frac{1}{2}(M + m)u'^2$$

(entering plate)

$$\begin{aligned}
 &= \frac{1}{2} mu^2 - \frac{1}{2} (M+m) \left(\frac{m}{M+m} u \right)^2 \\
 &= \frac{1}{2} mu^2 \left[1 - \frac{m}{M+m} \right] = \frac{1}{2} mu^2 \left(\frac{M}{M+m} \right) \\
 &= Fh' \quad \dots(ii)
 \end{aligned}$$

Dividing Eq. (ii) by Eq. (i),

$$\begin{aligned}
 \frac{h'}{h} &= \frac{M}{M+m} \\
 \text{i.e.,} \quad h' &= \left(\frac{M}{M+m} \right) h
 \end{aligned}$$

Option (a) is correct.

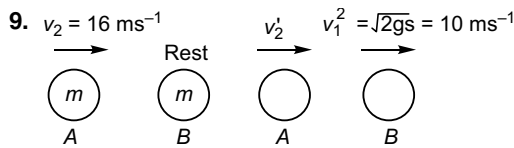

Now, $v_1' = \frac{1+e}{2} v_2$ (entering phase)

$\therefore 10 = \frac{1+e}{2} \cdot 16$

i.e., $e = \frac{1}{4}$

Option (b) is correct.

10. $y_{CM} = \frac{(l \cdot b) \frac{l}{2} + \left(\frac{1}{2} L \cdot b \right) \left(l + \frac{L}{3} \right)}{(l \cdot b) + \left(\frac{1}{2} L \cdot b \right)}$

$$l = \frac{\frac{bl^2}{2} + \frac{bLl}{2} + \frac{L^2b}{6}}{bl + \frac{bL}{2}} \quad \left[\begin{array}{l} y_{CM} = l \\ \text{according} \\ \text{to question} \end{array} \right]$$

or $l \left[l + \frac{L}{2} \right] = \frac{l^2}{2} + \frac{Ll}{2} + \frac{L^2}{6}$

or $\frac{l^2}{2} = \frac{L^2}{6}$

or $l = \frac{L}{\sqrt{3}}$

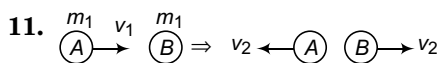

$m_1 v_1 = m_2 v_2 - m_1 v_2$... (i)

$e = 1$

$\therefore 2v_2 = v_1$

$\therefore m_1(2v_2) = m_2 v_2 - m_1 v_2$

$\therefore 3m_1 = m_2$
or $\frac{m_1}{m_2} = \frac{1}{3}$

12. As the resultant of the velocities of 1st and 2nd are just opposite to that of 3rd, the 4th particle will travel in the line in which 3rd is travelling.

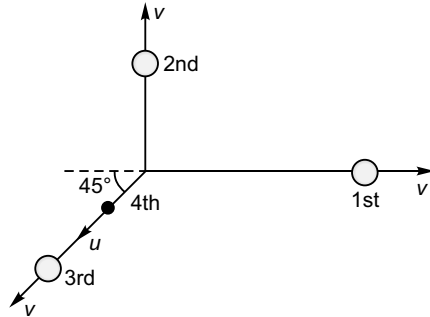

Let the velocity of 4th particle is u as shown in figure.

$\therefore u \cos 45^\circ + v \cos 45^\circ = v$

i.e., $u = v(\sqrt{2} - 1)$

Total energy released

$= \frac{1}{2} mv^2 + \frac{1}{2} mv^2 + \frac{1}{2} mv^2 + \frac{1}{2} m [v(\sqrt{2} - 1)]^2$

$= \frac{1}{2} mv^2 [3 + (\sqrt{2} - 1)^2] = mv^2 [3 - \sqrt{2}]$

Option (a) is correct.

13.

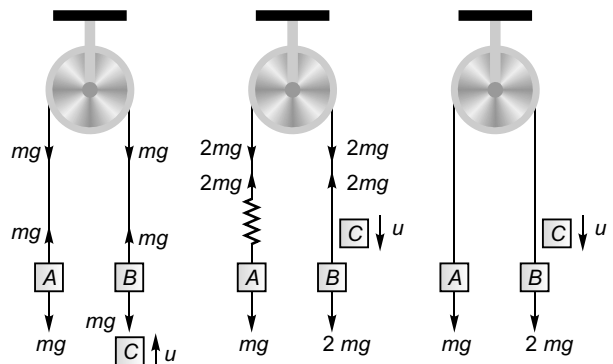

$mu = 2mv_1$ C will increase the tension in the string.

i.e., $v_1 = \frac{u}{2}$

$mu = 2mv_2$

i.e., $v_2 = \frac{u}{2}$

C will also increase the weight of B when collision takes place. Thus,

$mu = (2m + m)v_3$

i.e., $v_3 = \frac{u}{3}$

$$\begin{aligned} \therefore v_1 : v_2 : v_3 \\ = \frac{u}{2} : \frac{u}{2} : \frac{u}{3} = 3 : 3 : 2 \end{aligned}$$

Option (b) is correct.

14.

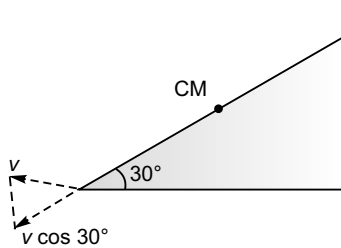

$$\begin{aligned} v_{CM} &= v \cos 30^\circ \\ &= v \frac{\sqrt{3}}{2} \end{aligned}$$

Option (a) is correct.

15. $\vec{r}_{CM} = \hat{i}$

\vec{r}_1 (position vector of lighter piece)

$$= 3 \hat{i} + 2 \hat{j} - 4 \hat{k}$$

$$\vec{r}_{CM} = \frac{m_1 \vec{r}_1 + m_2 \vec{r}_2}{m_1 + m_2}$$

$$\vec{r}_2 = \frac{(m_1 + m_2) \vec{r}_{CM} - m_1 \vec{r}_1}{m_2}$$

$$= \frac{2 \hat{i} - \frac{2}{3} (3 \hat{i} + 2 \hat{j} - 4 \hat{k})}{\frac{4}{3}}$$

$$= \frac{1}{4} [6 \hat{i} - 2(3 \hat{i} + 2 \hat{j} - 4 \hat{k})]$$

$$= \frac{1}{4} [-4 \hat{j} + 8 \hat{k}]$$

$$= -\hat{j} + 2 \hat{k}$$

\therefore The heavier part will be at $(0, -1, 2)$.

Option (d) is correct.

16. Motion of A :

$$\frac{h}{2} = \frac{1}{2} g t^2, v_A \text{ (at time } t) = g t = \sqrt{gh}$$

$$\text{i.e., } t = \sqrt{\frac{h}{g}}$$

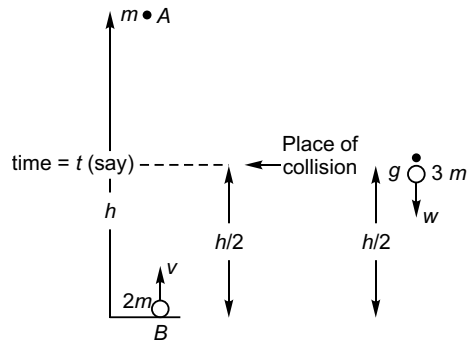

Motion of B :

$$\frac{h}{2} = v \frac{\sqrt{h}}{g} - \frac{1}{2} g \frac{h}{g}$$

$$\text{i.e., } h = v \sqrt{\frac{h}{g}}$$

$$\therefore v = \sqrt{gh}$$

$$v_B = \sqrt{gh} - g \cdot \sqrt{\frac{h}{g}} = 0$$

Collision of A and B at time t :

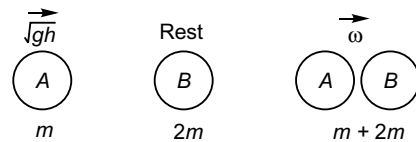

$$m \sqrt{gh} = 3m \omega$$

$$\therefore \omega = \frac{\sqrt{gh}}{3}$$

Velocity of the combined mass when it reach ground

$$v'^2 = \omega^2 + 2gh$$

$$= \frac{gh}{9} + 2gh$$

$$= \frac{g}{9} \sqrt{19gh}$$

$$\text{i.e., } v' = \frac{\sqrt{19gh}}{3}$$

Option (d) is correct.

17. u = velocity of man w.r.t. cart

Let v = velocity of cart w.r.t. ground

\therefore Velocity of man w.r.t. ground = $u + v$

$$m(u + v) + 2mv = 3m \cdot 0$$

$$\therefore v = -\frac{u}{3}$$

Work done = KE gained by man and cart

$$= \frac{1}{2} m(u + v)^2 + \frac{1}{2} 2mv^2$$

$$\begin{aligned}
 &= \frac{1}{2} m \left(u - \frac{u}{3} \right)^2 + \frac{1}{2} 2m \left(-\frac{u}{3} \right)^2 \\
 &= \frac{1}{2} m \cdot \frac{4u^2}{9} + \frac{1}{2} 2m \frac{u^2}{9} \\
 &= \frac{2mu^2}{3} + \frac{mu^2}{9} \\
 &= \frac{7}{9} mu^2
 \end{aligned}$$

Option (d) is correct.

18. $v_{CM} = \frac{30m + 50m}{m + m}$
 $= 40 \text{ m/s upwards.}$

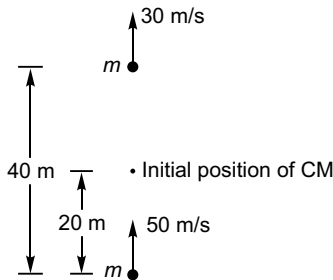

If the velocity of CM becomes zero at displacements

$$0^2 = 40^2 + 2(-10)s$$

$$\Rightarrow s = 80 \text{ m}$$

\therefore Maximum height attained by CM

$$= 20 \text{ m} + 80 \text{ m}$$

$$= 100 \text{ m}$$

Option (c) is correct.

19. As the masses are equal and the collision is elastic, the particles will exchange their velocities as shown in figure.

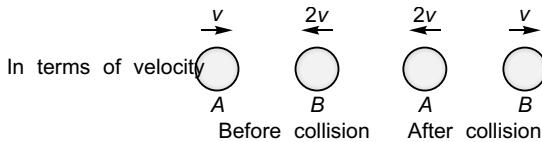
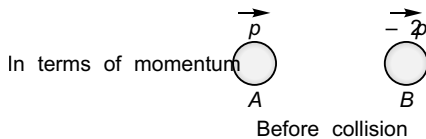

Gain in KE of 1st particle

$$= \frac{1}{2} m (-2v)^2 - \frac{1}{2} mu^2$$

$$\begin{aligned}
 &= 2mv^2 - \frac{1}{2} mv^2 \\
 &= \frac{3}{2} mv^2 \\
 &= \frac{3p^2}{2m}
 \end{aligned}$$

Option (c) is correct.

20. According to question

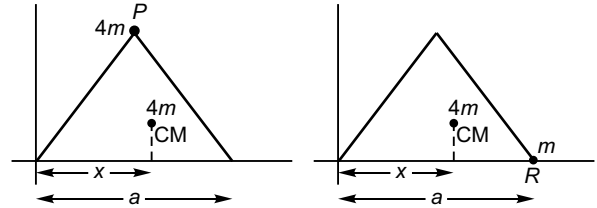

$$\frac{(4m)x + (4m)\frac{a}{2}}{4m + 4m} = \frac{(4m)x + (m)a}{4m + m}$$

or $\frac{x}{2} + \frac{a}{4} = \frac{4x + a}{5}$

i.e., $x = \frac{a}{6}$

Option (b) is correct.

21. x_{CM} of Fig. 1 will as that of Fig. 2.

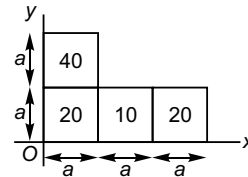

Fig. 1

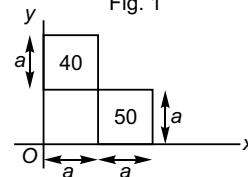

Fig. 2

$$\begin{aligned}
 x_{CM} &= \frac{40 \cdot \frac{a}{2} + 50 \cdot \frac{3a}{2}}{40 + 50} \\
 &= \frac{20a + 75a}{90} \\
 &= \frac{95a}{90} = \frac{19a}{18}
 \end{aligned}$$

$$y_{CM} = \frac{40 \cdot \frac{3a}{2} + 50 \cdot \frac{a}{2}}{40 + 50} \left[\begin{array}{l} \text{There is no} \\ \text{need to find} \\ \text{the value of } y_{CM} \end{array} \right]$$

$$= \frac{17a}{18}$$

Option (a) is correct.

22. Conservation of momentum along y-axis

$$m_0 \frac{v_0}{\sqrt{2}} \sin 45^\circ = 2m_0 v \sin \theta$$

$$\text{i.e., } 2v \sin \theta = \frac{v_0}{2} \quad \dots(i)$$

Conservation of momentum along x-axis.

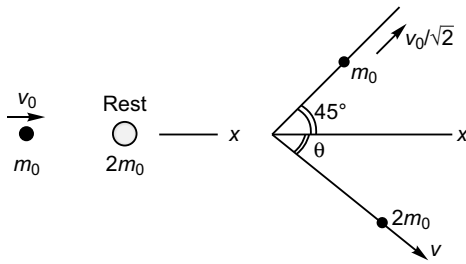

$$m_0 \frac{v_0}{\sqrt{2}} \cos 45^\circ + 2m_0 v \cos \theta = m_0 v_0$$

$$\text{i.e., } 2v \cos \theta = \frac{v_0}{2} \quad \dots(ii)$$

Squaring and adding Eqs. (i) and (ii),

$$2v = \frac{v_0}{2} \sqrt{2}$$

$$\therefore v = \frac{v_0}{2\sqrt{2}}$$

Option (b) is correct.

23. $\frac{1}{2} kx_0^2 = \frac{1}{2} m_2 v_2^2$

$$\text{i.e., } v_2 = x_0 \sqrt{\frac{k}{m_2}}$$

$$v_{CM} = \frac{m_1 \times 0 + m_2 v_2}{m_1 + m_2}$$

(When wall just breaks off the velocity of mass m_1 would be zero)

$$= \frac{m_2}{m_1 + m_2} v_2$$

$$= \frac{m_2}{m_1 + m_2} x_0 \sqrt{\frac{k}{m_2}}$$

$$= \frac{x_0}{m_1 + m_2} \sqrt{k m_2}$$

Option (b) is correct.

24. Velocity of 2nd ball when 1st with velocity v strikes 2nd at rest

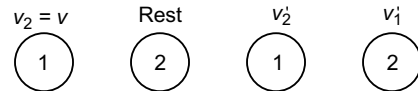
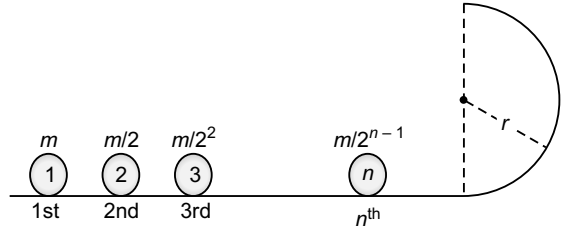

$$m_2 = m \quad m_1 = m/2$$

$$v_1' = \frac{2m_2}{m_1 + m_2} v_2 = \frac{2m}{\frac{m}{2} + m} v = \frac{4}{3} v$$

Velocity of 3rd ball when 2nd with velocity $\frac{4}{3}v$ strikes 3rd at rest

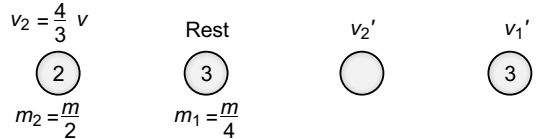

$$m_2 = \frac{m}{2} \quad m_1 = \frac{m}{4}$$

$$v_1' = \frac{2m_2}{m_1 + m_2} v_2 = \frac{2 \cdot \frac{m}{2}}{\frac{m}{4} + \frac{m}{2}} \cdot \frac{4}{3} v$$

$$= \frac{4}{3} \cdot \frac{4}{3} v$$

$$= \left(\frac{4}{3}\right)^2 v$$

Velocity of 3rd ball = $\left(\frac{4}{3}\right)^{3-1} v$

As in every collision $\frac{m_2}{m_1 + m_2} = \frac{4}{3}$

The velocity of nth ball = $\left(\frac{4}{3}\right)^{n-1} v$

Now, this must be equal to $\sqrt{5gr}$ for it to complete the circle

$$\therefore \left(\frac{4}{3}\right)^{n-1} v = \sqrt{5gr}$$

$$\text{i.e., } v = \left(\frac{3}{4}\right)^{n-1} \sqrt{5gr}$$

Option (a) is correct.

25. Impulse given to the block will also release it from abstraction besides giving and then imparting the restoring force on it due to velocity to it 5cm of the spring expansion will accelerate it.

$$\text{Impulse} = 4 \text{ kg ms}^{-1}$$

$$\text{Initial velocity } (u) = \frac{4 \text{ kg ms}^{-1}}{2 \text{ kg}} = 2 \text{ ms}^{-1}$$

Average Acceleration (a)

$$\begin{aligned} &= \frac{kx}{2m} = \frac{4000 \times \left(\frac{5}{100}\right)}{2 \times 2} \\ &= 50 \text{ m/s}^2 \end{aligned}$$

$$\text{Displacement } (s) = x = \frac{5}{100} \text{ m}$$

$$\begin{aligned} \therefore v^2 &= u^2 + 2as \\ &= 2^2 + 2 \times 50 \times \frac{5}{100} \end{aligned}$$

$$= 4 + 5$$

$$= 9$$

$$\therefore v = 3 \text{ ms}^{-1}$$

Option (b) is correct.

26. **Compression in spring** Velocity gained by block when the spring is at its natural length will compress the spring.

$$\frac{1}{2} kx^2 = \frac{1}{2} mv^2$$

$$x = v \sqrt{\frac{m}{k}}$$

$$= 3 \sqrt{\frac{2}{4000}}$$

$$= \sqrt{\frac{2 \times 9 \times 5}{4000 \times 5}}$$

$$= \sqrt{\frac{45}{10000}}$$

$$= \frac{6.7}{100} \text{ m}$$

$$= 6.7 \text{ cm}$$

Spring at its natural length.

Block at rest first time due to some reason.

Restoring force brings the spring to its natural length and block attains a velocity of 3 ms^{-1} .

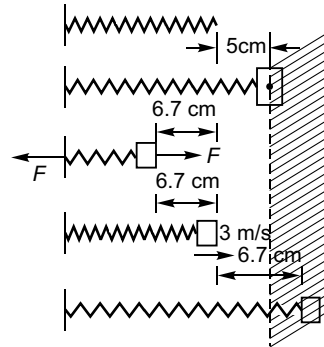

KE of the block moves blocks ahead and the spring stretches by 6.7 cm but the block does not return due to same region. Block is now at rest for the second time.

$$\begin{aligned} \therefore \text{Distance travelled by block when it comes to rest for the second time} &= (5 + 6.7 + 6.7 + 6.7) \text{ cm} \\ &= 25 \text{ cm approx.} \end{aligned}$$

Option (b) is correct.

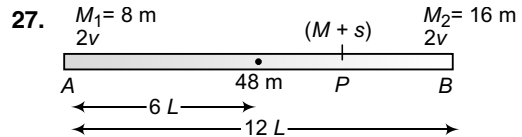

$$8m \times AP = 16m \times (12L - AP)$$

$$AP = 24L - 2AP$$

$$3AP = 24L$$

$$AP = 8L$$

As the CM of M and S does not change, the CM of the bar shall also not change *i.e.*, the displacement of bar will be zero.

Let x be the displacement of rod.

$$\begin{aligned} \therefore x \times 8m + (x + 6L) 48m + (x + 12L) 16m &= (6L \times 48m) + (8L \times 24m) \end{aligned}$$

$$\text{i.e., } x = 0 \text{ m}$$

i.e., no displacement of bar.

Option (d) is correct.

$$28. v_{\text{CM}} \text{ of } M \text{ and } S = \frac{8m(2v) + 16m(-v)}{8m + 16m} = 0$$

There CM of M and S will not change while they move *i.e.*, the point P (where they meet) is at the edge of the table supporting the end B .

Option (b) is correct.

29. When the spider eats up the moth and travels towards A with velocity $\frac{v}{2}$ relative to rod.

$$24 m \left(\frac{v}{2} + v_R \right) + 48 m v_R = 0$$

[v_R = velocity (absolute) of rod]

$$\Rightarrow v_R = -\frac{v}{6}$$

Option (c) is correct.

30. Time taken by spider to reach point A starting from point B

$$= \frac{4L}{v} + \frac{8L}{v/2}$$

$$= \frac{20L}{v} = \frac{20L}{L/T} = 20T$$

$$= 20 \times 4 = 80 \text{ s}$$

31. Form CM not to shift

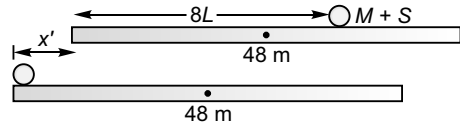

$$\Rightarrow (x' + 8L) 24 m + (x' + 6L) 48 m = 64 \times 48 m$$

$$\text{i.e., } x' = -\frac{8L}{3}$$

Option (a) is correct.

More than One Correct Options

1. Along vertical : $2mV \sin \theta = m \cdot \frac{v}{2} \sin 45^\circ$

$$\text{i.e., } 2V \sin \theta = \frac{v}{2\sqrt{2}} \quad \dots(i)$$

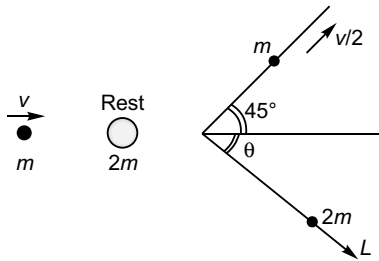

Along horizontal :

$$mv = m \frac{v}{2} \cos 45^\circ + 2mV \cos \theta$$

$$\text{i.e., } 2V \cos \theta = v \left(1 - \frac{1}{2\sqrt{2}} \right) \quad \dots(ii)$$

Squaring and adding Eq. (i) and (ii),

$$8V^2 = \left(\frac{v}{2\sqrt{2}} \right)^2 + \left(v - \frac{v}{2\sqrt{2}} \right)^2$$

$$= \frac{v^2}{8} + v^2 + \frac{v^2}{7} - 2 \cdot v \cdot \frac{v}{2\sqrt{2}}$$

$$= \frac{5v^2}{4} - \frac{v^2}{\sqrt{2}}$$

Dividing Eq. (ii) by Eq. (i)

$$\tan \theta = \frac{1}{\frac{2\sqrt{2}}{2\sqrt{2}-1} - \frac{1}{2\sqrt{2}}}$$

$$= \frac{1}{2\sqrt{2}-1} < 1$$

$$\therefore \theta < 45^\circ$$

Thus, the divergence angle between the particles will be less than $\frac{\pi}{2}$.

Option (b) is correct.

$$\text{Initial KE} = \frac{1}{2} m v^2$$

$$\text{Final KE} = \frac{1}{2} m \left(\frac{v}{2} \right)^2 + \frac{1}{2} 2mV^2$$

$$= \frac{1}{2} m v^2 \left[\frac{1}{4} + 2 \cdot \frac{5}{32} - 2 \cdot \frac{1}{8\sqrt{2}} \right]$$

As Final KE < Initial KE

Collision is inelastic.

Option (d) is correct.

2. $v_2' = \frac{m_2 - m_1}{m_1 + m_2} v_2$

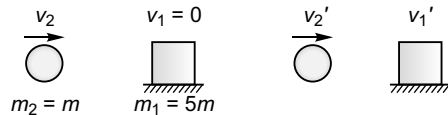

$$= \frac{m - 5m}{5m + m} v_2$$

$$= -\frac{2}{3} v_2$$

$$= -\frac{2}{3} \sqrt{2gl}$$

$$T - \frac{mv_2'^2}{l} = mg$$

or
$$T = \frac{mv_2'}{l} + mg$$

$$= \frac{m \cdot 8g}{9} + mg$$

$$= \frac{17mg}{9}$$

Option (a) is correct.

Velocity of block

$$v_1' = \frac{2m_2}{m_1 + m_2} v_2$$

$$= \frac{2m}{5m + m} \cdot \sqrt{2gl}$$

$$= \frac{1}{3} \sqrt{2gl}$$

Option (c) is correct.

Maximum height attained by pendulum bob

$$= \frac{v_2'^2}{2g} = \frac{8gl/9}{2g} = \frac{4l}{g}$$

Option (d) is correct.

3. $v \cos \phi = u \cos \theta \Rightarrow \frac{v}{u} = \frac{\cos \theta}{\cos \phi}$

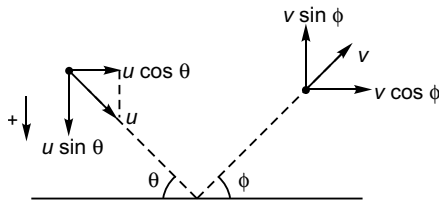

and

$$e = \frac{v \sin \phi}{u \sin \theta}$$

$$= \frac{\cos \theta}{\cos \phi} \times \frac{\sin \phi}{\sin \theta}$$

$$= \frac{\tan \phi}{\tan \theta}$$

Option (b) is correct.

Change in momentum of particle

$$= (-mv \sin \phi) - (+mu \sin \theta)$$

∴ Impulse delivered by floor to the particle

$$= mv \sin \phi + mu \sin \theta$$

$$= mv \sin \theta \left[\frac{\sin \phi}{\sin \theta} + \frac{u}{v} \right]$$

$$= mv \sin \theta \left[\frac{u}{v} e + \frac{u}{v} \right]$$

$$= mu \sin \theta (1 + e)$$

Option (d) is correct.

$$u \sqrt{1 - (1 - e^2) \sin^2 \theta}$$

$$= u \sqrt{1 - \sin^2 \theta + e^2 \sin^2 \theta}$$

$$= u \sqrt{\cos^2 \theta + e^2 \sin^2 \theta}$$

$$= u \sqrt{\cos^2 \theta + \frac{v^2}{u^2} \sin^2 \theta}$$

$$= \sqrt{u^2 \cos^2 \theta + v^2 \sin^2 \theta}$$

$$= \sqrt{v^2 \cos^2 \phi + v^2 \sin^2 \phi}$$

$$= v$$

Option (c) is correct.

$$\cos^2 \theta + e^2 \sin^2 \theta$$

$$= \cos^2 \theta + \frac{\tan^2 \phi}{\tan^2 \theta} \sin^2 \theta$$

$$= \cos^2 \theta (1 + \tan^2 \phi)$$

$$= \cos^2 \theta \sec^2 \phi$$

$$= \frac{\cos^2 \theta}{\cos^2 \phi}$$

$$= \frac{v^2}{u^2} = \frac{\text{Final KE}}{\text{Initial KE}}$$

Option (d) is correct.

4. $\vec{u} = (3\hat{i} + 2\hat{j}) \text{ ms}^{-1}$

$$\frac{\vec{u}}{M} \cdot \frac{\vec{v}}{m} = (-2\hat{i} + \hat{j}) \text{ m/s}$$

Impulse received by particle of mass m

$$= -m\vec{u} + m\vec{v}$$

$$= -m(3\hat{i} + 2\hat{j}) + m(-2\hat{i} + \hat{j})$$

$$= -m(5\hat{i} + \hat{j}) \text{ unit}$$

Option (b) is correct.

Impulse received by particle of mass M

$$= -(\text{impulse received by particle of mass } m)$$

$$= m(5\hat{i} + \hat{j})$$

Option (d) is correct.

5. $T = m_1 a$

and $m_2 g - T = m_2 a$
 Solving, $a = \frac{m_2}{m_1 + m_2} g$

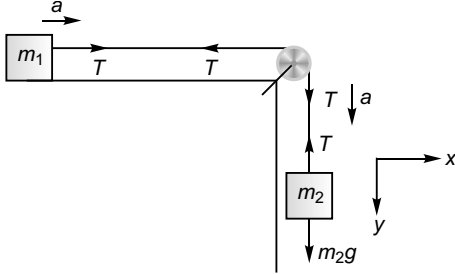

$$(a_{CM})_x = \frac{m_1 a + m_2 \cdot 0}{m_1 + m_2}$$

$$= \frac{m_1}{m_1 + m_2} a$$

$$= \frac{m_1 m_2}{(m_1 + m_2)^2} g$$

Option (b) is correct.

$$(a_{CM})_y = \frac{m_1 \cdot 0 + m_2 a}{(m_1 + m_2)}$$

$$= \frac{m_2}{m_1 + m_2} a$$

$$= \left(\frac{m}{m_1 + m_2} \right)^2 g$$

Option (c) is correct.

6. As the block comes down, the CM of the system will also come down *i.e.*, it does not remain stationary.

$$a_{CM} = \frac{mg}{m + M} \neq g$$

a_{CM} is downwards and also $a_{CM} < g$.

Option (d) is correct.

As no force acts along horizontal direction, the momentum of the system will remain conserved along horizontal direction.

Option (c) is correct.

7. Velocity of B after collision :

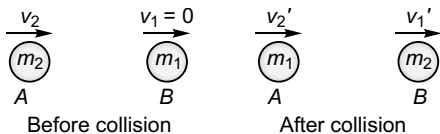

$$v_1' = \left(\frac{1+e}{2} \right) v_2$$

$$= \frac{3}{4} v \text{ [as } e = \frac{1}{2} \text{ and } v_2 = v \text{ (given)]}$$

$$\neq \frac{v}{2}$$

Impulse given by A to B

$$= \text{change in momentum of B}$$

$$= m \left(\frac{3}{4} v \right) - m \cdot 0$$

$$= \frac{3}{4} mv$$

Option (b) is correct.

Velocity of A after collision

$$v_2' = \left(\frac{1-e}{2} \right) v_2$$

$$= \frac{v}{4}$$

Loss of KE during collision

$$= \frac{1}{2} m v_2^2 - \frac{1}{2} m (v_1'^2 + v_2'^2)$$

$$= \frac{1}{2} m \left[v^2 - \left(\frac{v}{4} \right)^2 - \left(\frac{3v}{4} \right)^2 \right]$$

$$= \frac{3}{16} m v^2$$

Option (c) is correct.

8. As the mass of the system keeps on decreasing momentum of the system does not remain constant.

Thrust force is developed on the rocket due to Newton's 3rd law of motion.

Option (b) is correct.

$$\text{As, } a = \frac{dv}{dt} = \frac{v_i}{m} \left(- \frac{dm}{dt} \right) - g$$

The value of a will remain constant if v_i and $-\frac{dm}{dt}$ are constant.

Option (c) is correct.

$$F_{net} = F_t \text{ (Thrust force due to gas ejection)}$$

$$- W \text{ (weight of rocket)}$$

$$a = \frac{F_{net}}{m}$$

Thus, Newton's 2nd law is applied.

Option (d) is correct.

Match the Columns

1. If x_0 is the compression made in the spring, the restoring force on B will decrease from kx_0 to zero as the spring regains its original length. Thus, the acceleration of B will also decrease from $\frac{kx_0}{m_B}$ to zero.

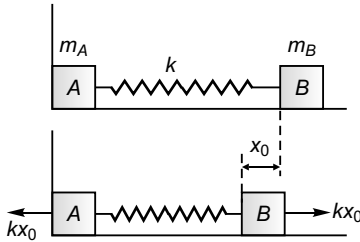

So, the a_{CM} will also decrease from $\frac{kx_0}{m_A + m_B}$ to zero.

\therefore (a) \rightarrow (r)

When spring is released after compressing it, the restoring on B will accelerate it towards right while the reaction force on A will apply a force on the wall which in turn will apply equal and opposite force on A and consequently A will travel towards right. As both travel towards right the velocity of CM will be maximum in the beginning.

After this A will start compressing the spring and at a certain instant when the spring is compressed to maximum value both the blocks will travel towards right with a constant velocity and then the velocity of CM will become constant.

\therefore (b) \rightarrow (q)

As the blocks will never move along y -axis, the y -component of the CM of the two blocks will not change.

\therefore (d) \rightarrow (p)

As the two blocks will keep on moving towards right (surface below being smooth) the x -coordinate of the CM of the blocks will keep on increasing.

\therefore (c) \rightarrow (s)

2. Initial $a_{CM} = \frac{m(+g) + m(+g)}{m + m}$

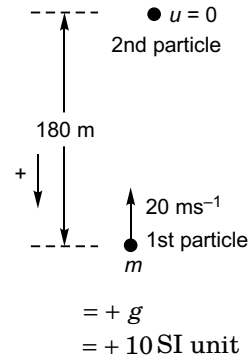

\therefore (a) \rightarrow (q)

Initial $v_{CM} = \frac{m(-20) + m \times 0}{m + m}$

$= -10$

$\therefore |v_{CM}| = 10 \text{ SI unit}$

\therefore (b) \rightarrow (q)

For the time taken by the first particle to return to ground

$$s = ut + \frac{1}{2}at^2$$

$$0 = (-20)t + 5t^2$$

$\Rightarrow t = 4 \text{ s}$

Now, as the collision of the first particle with the ground is perfectly inelastic, the first particle will remain on ground at rest.

Now, let us find the position of 2nd particle at $t = 5 \text{ s}$

$$s = (0)5 + \frac{1}{2}(10)5^2$$

$= 125 \text{ m}$

The particle (2nd) will still be in space moving downwards.

$$a_{CM} = \frac{m \cdot 0 + m \cdot g}{m + m}$$

$= \frac{g}{2} = 5 \text{ (SI unit)}$

\therefore (c) \rightarrow (p)

Velocity of 2nd particle at $t = 5 \text{ s}$

$$v = 0 + 10 \times 5 = 50 \text{ ms}^{-1}$$

∴ At $t = 5$ s

$$v_{CM} = \frac{m \cdot 0 + m \cdot 50}{m + m}$$

$$= 25 \quad (\text{SI unit})$$

∴ (d) → (s)

3. Initial KE of block $B = 4$ J

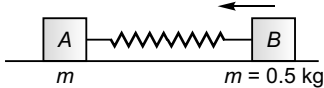

$$\therefore \frac{1}{2} \times 0.5 \times u^2 = 4$$

$$\Rightarrow u = 4 \text{ ms}^{-1}$$

$$\therefore \text{Initial momentum of } B = 0.5 \times 4$$

$$= 2 \text{ kg ms}^{-1}$$

∴ (a) → (r)

Initial momentum

$$p_{CM} = p_A + p_B$$

$$= 0 + 2$$

$$= 2 \text{ kg ms}^{-1}$$

∴ (b) → (r)

Velocity given to block B will compress the spring and this will gradually increase the velocity of A . When the spring gets compressed to its maximum both the blocks will have the same velocities *i.e.*, same momentum as both have same mass.

$$p_A = p_B$$

(at maximum compression of the spring)

But, $p_A + p_B =$ initial momentum of B .

$$\therefore p_A + p_A = 2$$

i.e., $p_A = 1 \text{ kgms}^{-1}$

∴ (c) → (q)

After the maximum compression in the spring, the spring will gradually expand but now the velocity of block A will increase and that of B will decrease and when the spring attains maximum expansion the velocity of B will be zero and so will be its momentum.

∴ (d) → (p)

4. If collision is elastic, the two blocks will interchange their velocities (mass of both balls being equal).

Thus, velocity of A after collision = v

∴ (a) → (r)

If collision is perfectly inelastic, the two balls will move together (with velocities V).

$$\therefore mv = (m + m)V$$

$$\Rightarrow V = \frac{v}{2}$$

∴ (b) → (s)

If collision is inelastic with $e = \frac{1}{2}$,

$$v_1' = \frac{1 + e}{2} \cdot v_2$$

$$= \frac{1 + \frac{1}{2}}{2} \cdot v \quad [\because v_2 = v \text{ (given)}]$$

$$= \frac{3}{4}v$$

∴ (c) → (p)

If collision is inelastic with $e = \frac{1}{4}$,

$$v_1' = \left(1 + \frac{1}{4}\right) \frac{v}{2} = \frac{5}{8}v$$

∴ (d) → (q).

5. If A moves x towards right

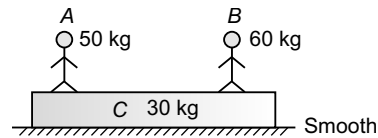

Let plank (along with B) move by x' to the right.

$$\therefore \frac{x \times 30 + x'(60 + 30)}{30 + (60 + 30)} = 0$$

$$\text{i.e., } x' = -\frac{x}{3}$$

$$= \frac{x}{3}, \text{ towards left.}$$

∴ (a) → (r)

If B moves x towards left

Let plank (along with A) move x' to the left

$$\therefore \frac{x \cdot 60 + x'(30 + 30)}{60 + (30 + 30)} = 0$$

$$\text{i.e., } x' = -x$$

$$= x, \text{ towards right}$$

∴ (b) → (p)

If A moves x towards right and B moves x towards left.

Let plank moves x' towards right

$$\therefore \frac{30 \times x + 60(-x) + 30(x')}{30 + (60) + (30)} = 0$$

i.e., $x' = x$
 $= x$, towards right

∴ (c) → (p)

If A and B both move x towards right.

Let plank moves x' towards right

$$\therefore \frac{(30 + 60)x + 30x'}{(30 + 60) + 30} = 0$$

i.e., $x' = -3x$
 $= 3x$, towards right

∴ (d) → (s)

6. For man to be in equilibrium

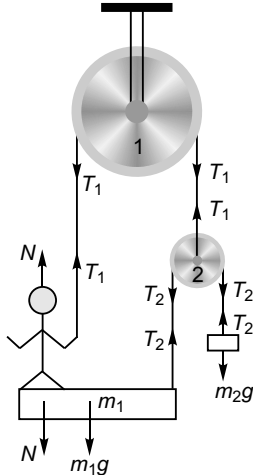

$$N + T_1 = W \quad \dots(i)$$

For the block of mass m_1 to be in equilibrium

$$T_2 = N + m_1g \quad \dots(ii)$$

For the block of mass m_2 to be in equilibrium

$$T_2 = m_2g \quad \dots(iii)$$

For the equilibrium of pulley 2

$$T_1 = 2T_2 \quad \dots(iv)$$

Solving Eqs. (i), (ii), (iii) and (iv)

$$W = 3m_2g - m_1g$$

$$= (3m_2 - m_1)g$$

$$= (60 - 10)10$$

$$= 500 \text{ N}$$

∴ (a) → (r)

For the equilibrium of man

$$N = W - T_1$$

$$= W - 2T_2$$

$$= W - 2(N + m_1g)$$

i.e., $3N = W - 2m_1g$
 $N = 100 \text{ N}$

∴ (d) → (s)

Force exerted by man on string to accelerate the centre of mass of the system upwards

Centre of mass of the system will move upwards if man move upward.

i.e., when $T_1 > W - N$
 $> 500 - 10$
 $> 400 \text{ N}$

Options are 500 N and 600 N.

∴ (b) → (r) and (s).

Force (T_1) exerted by man on string to accelerate the centre of mass of the system.

Centre of mass of the system will move downward if man moves downward.

i.e., when $T_1 < W - N$
 $< 400 \text{ N}$

Options are 100 N and 150 N.

∴ (c) → (q).

7. $v_{\text{CM}} = \frac{2 \times 3 + 0 \times 6}{3 + 6}$

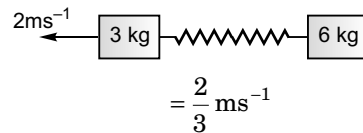

When both the blocks move with same velocity (say v) deformation in the spring will be maximum

$$2 \times 3 = 3v + 6v$$

i.e., $v = \frac{2}{3} \text{ ms}^{-1}$
 $= \text{velocity of A}$
 $= \text{velocity of B}$

$$v_{CM} = \frac{3 \times \frac{2}{3} + 6 \times \frac{2}{3}}{3 + 6}$$

$$= \frac{2}{3} \text{ ms}^{-1}$$

When both the blocks move with same velocities, each will be at rest w.r.t. the other

∴ (a) → (p), (r), (s)

(b) → (p), (r), (s)

Minimum speed of 3 kg block will be $\frac{2}{3} \text{ ms}^{-1}$ and at that moment velocity of CM

will be $\frac{2}{3} \text{ ms}^{-1}$.

∴ (c) → (p)

Initial velocity of 6 kg block is zero.

When the spring is compressed to maximum value the velocity of 6 kg will be maximum and the velocity of CM will be $\frac{2}{3} \text{ ms}^{-1}$ (as explained above).

∴ (c) → (p).

$$8. v_{CM} = \frac{2 \times 5 + 1(-10)}{2 + 1}$$

$$= 0 \text{ ms}^{-1}$$

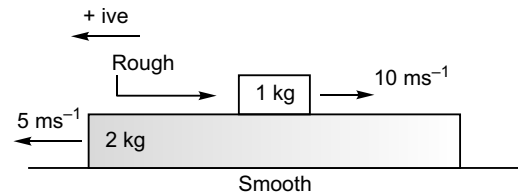

∴ (a) → (r)

$$\text{Momentum of CM} = 2(+5) + 1(-10)$$

$$= 0 \text{ kg ms}^{-1}$$

∴ (b) → (r)

Velocity and so the momentum of 1 kg block will decrease to zero as the surface below is rough.

∴ (c) → (q)

Velocity and so the KE of 2 kg block will decrease to zero when the velocity of 1 kg block becomes zero (according to law of conservation of momentum).

∴ (d) → (q).