

TECHNICAL REPORT

STATE OF THE ART: CCS TECHNOLOGIES 2023



GLOBAL CCS
INSTITUTE

HUGH BARLOW
Consultant CCS Technology

SHAHRZAD S M SHAHI
Consultant CCS Technology

MATTHEW LOUGHREY
Principal Consultant CCS Technology

CONTENTS

| | |
|--|------------|
| FOREWORD | 4 |
| CAPTURE | 6 |
| AIR LIQUIDE | 8 |
| AKER CARBON CAPTURE | 18 |
| B&W | 22 |
| CAPTURA | 26 |
| CARBONCAPT | 28 |
| CARBON CLEAN | 32 |
| CARBON ENGINEERING | 36 |
| C-CAPTURE | 40 |
| CAPSOL TECHNOLOGIES | 44 |
| CO2CRC | 48 |
| DELTA CLEAN TECH | 52 |
| ELESSENT CLEAN TECHNOLOGIES | 54 |
| FUELCELL ENERGY | 58 |
| HEIRLOOM | 62 |
| HUANENG CLEAN ENERGY RESEARCH INSTITUTE (HNCERI) | 64 |
| HONEYWELL | 68 |
| K2CO2 | 72 |
| KC8CAPTURE | 74 |
| LINDE | 78 |
| NET POWER | 90 |
| NOVOZYMES | 94 |
| NUADA (FORMERLY MOF TECHNOLOGIES) | 98 |
| SHELL AND TECHNIP ENERGIES | 100 |
| SINOPEC NANJING CHEMICALS RESEARCH INSTITUTE | 104 |
| SUMITOMO SHI FW | 108 |
| TOSHIBA | 114 |
| SVANTE | 118 |
| TRANSPORTE | 120 |
| GHD | 122 |
| JFE STEEL | 126 |
| MAXTUBE GROUP | 130 |
| STORAGE | 134 |
| CMG | 136 |
| GETECH | 138 |
| HALLIBURTON | 142 |
| NSAI-PETRO | 154 |
| QUORUM SOFTWARE | 156 |
| FULL VALUE CHAIN | 164 |
| ABB | 166 |
| ASPENTECH | 168 |
| BAKER HUGHES | 170 |
| CHART & HOWDEN | 196 |
| CHEVRON | 200 |
| ENI | 204 |
| JCCS | 208 |
| NOV | 212 |
| OPENGOSIM LTD | 216 |
| RITE | 218 |
| SAIPEM | 226 |
| SICK | 232 |
| SLB | 236 |



FOREWORD

There is an urgent need for innovative, new technologies to reduce greenhouse gas emissions to tackle climate change and meet net-zero targets. Carbon Capture and Storage (CCS) covers a range of technologies that will be crucial in supporting these global efforts.

The uptake of CCS is growing at an unprecedented rate. While early CCS projects targeted easier to capture emissions sources, projects further into the energy transition need to address harder to abate emissions that are more expensive and challenging to address. Technological advancements are essential to improving the economics and ensuring the successful application of CCS to these more challenging emissions sources.

This year's Technology Compendium expands on the inaugural version in all categories with several new technologies. One of the key advancements is the development of new and improved methods for capturing carbon dioxide, including several new technologies utilizing calcium looping and metal organic frameworks (MOFs). For transport and storage, new technologies focused on robust design and monitoring are supporting the need to provide safe and optimized transport and storage infrastructure. This highlights the ongoing work to develop technologies to improve energy efficiency, reduce costs, and improve infrastructure performance for future CCS projects.

The year's Technology Compendium continues to showcase the breadth and depth of commercially-available CCS technologies worldwide. We look forward to seeing further growth and development of CCS technologies in coming years as we continue to fight the threat of climate change.

Matt Loughrey
Principal – CCS Technologies
Global CCS Institute
July 2023

Acknowledgements

We are grateful for the contributions and support of all the technology companies who have contributed to this publication.

Thank you to Hugh Barlow and Shahrzad Shahi for their invaluable editing and coordination of this report.

Special mentions also go to Yi Wu, Yasuo Murakami, Kazuko Miyashita, Erin Billeri, Spencer Schecht, Bruno Gerrits, and Sarah Hardman of the Global CCS Institute for their efforts and support.



CAPTURE





CRYOCAP™^{mw} (H₂, FG, OXY, STEEL, NG) AIR LIQUIDE

SUMMARY

Air Liquide has been designing gas separation technologies for more than 100 years, and has leveraged its industrial demonstration units on power plants, steel blast furnaces, and H₂ production plants to develop the Cryocap™ product line. Cryocap™ is an award-winning proprietary technological innovation for CO₂ capture that is unique in the world, using a cryogenic process (involving low temperatures to separate gases). Cryocap™ can be adapted to specific applications combining a variety of Air Liquide technologies. Customers can reduce their CO₂ emissions by up to 99% and have the possibility to valorize other molecules contained in the feed gas (e.g. CO, H₂, etc). Cryocap™ is a robust and pioneering technology available to service customers looking to reduce the carbon footprint of their production facilities.

To date, Cryocap™ is the only full-scale cryogenic capture technology with an industrial reference in operation in the world. Driven by innovation and the need to decarbonize carbon intensive processes, Cryocap™ reference examples date back to 2005 and the product line has since then been selected for multiple engineering studies, pre-

Front End Engineering & Design (pre-FEED), FEED, and implementation across four continents for a diverse set of industries. To further showcase its innovative and efficient design in CO₂ capture, Cryocap™ has resulted in several patent filings. It has also consistently been recognized by US and EU experts through several grant awards by EU Innovation Fund and US Department of Energy (DOE) in 2021 and 2022.

Our portfolio of cryogenic technologies includes:

- Cryocap™ H₂ for hydrogen production: Steam Methane Reformer (SMR), AutoThermal Reforming (ATR), or Partial Oxidation (POX)
- Cryocap™ FG for flue gases (optimal: >15% CO₂ dry basis)
- Cryocap™ Oxy for oxy combustion
- Cryocap™ Steel for steel production
- Cryocap™ NG for acid natural gas fields
- Cryocap™ XLL for large scale liquefaction (in a separate section)

Air Liquide cryogenic offerings for CO₂ capture and liquefaction

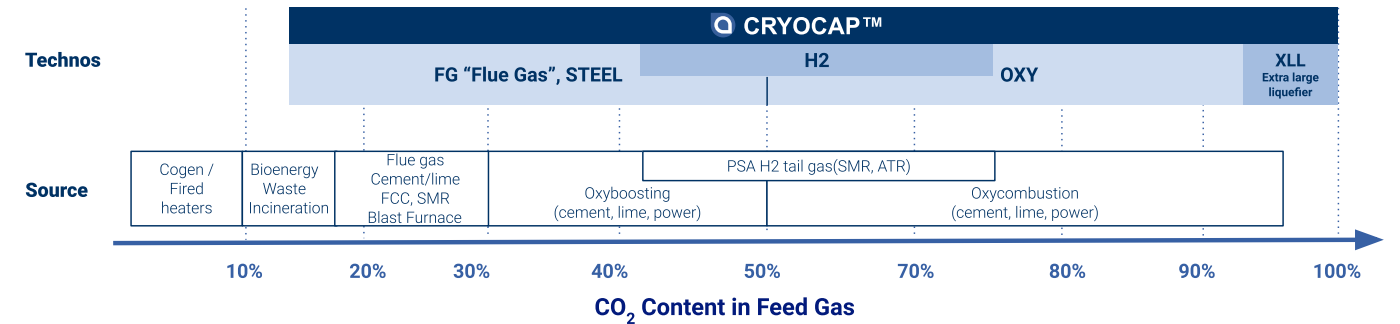

The first industrial deployment of this technology was made in Port-Jerome, France (Cryocap™ H₂), at the largest SMR Hydrogen production unit operated by Air Liquide. Since its startup in 2015, the plant has captured 100 ktpa CO₂ from an existing SMR while boosting H₂ production. The plant has been designed for ease of scalability; wherein all equipment in Port Jerome will be purely upscaled to larger scale CCS projects. After 8 years of operation, the Port Jerome site demonstrated:

- Proven robustness of design - no aging of key components over time
- Very high reliability: No H₂ production interruption, CO₂ availability > 99%
- Performances confirmed and stable over time
- Improvement thanks to continuous capitalization from operation to design

Port Jerome is one of the 4 sites in Europe able to produce Hydrogen certified low carbon, and has been integrated as a pilot site for the project CertifHy, the first Guarantee of Origin (GO) platform for Green and Low-Carbon Hydrogen. All Cryocap™ products benefit from 8 years of return of operational experience gained in Port Jerome.

Air Liquide has always been committed to innovation by improving its vast portfolio of patented technologies and customized solutions to meet and exceed customer expectations in terms of efficiency, safety, reliability and competitiveness to achieve energy transition goals. As a top technology provider with a longstanding experience in Engineering, Procurement, and Construction (EPC), we cover the entire project life-cycle: license engineering services / proprietary equipment, high-end engineering & design capabilities, project management & execution services. In addition, we also offer efficient customer services through our worldwide set-up.

BENEFITS

The entire Cryocap™ suite was designed to address the challenges experienced from traditional capture solutions. Our customers value the following Cryocap™ features:

- Minimizes overall carbon footprint: the technologies are electrically-driven (negligible steam) which maximize the CO₂ avoided by reduced indirect CO₂ emissions, with high CO₂ recovery (92 - 99%), and can be paired with renewable or low-carbon power supply
- High intrinsic process efficiency: the technology bricks are used in their optimum range
- Safety and no toxicity: solvent-free, and no toxic or flammable gases used
- Match the end specifications and high CO₂ product purity: all Cryocap™ produce either high pressure gaseous or liquid CO₂ at marginal extra cost and can meet the most stringent CO₂ specifications (>99.9%v)
- Favor synergies and optimize space: 1-step capture and liquefaction for any stream containing >15% CO₂ (dry basis), very compact solutions with flexible layout configuration and simplified infrastructure compared to steam-based solutions
- Improve productivity: for some applications (H₂ and steel), installing our product improves the efficiency of the original process or enable the co-production of valuable molecules (e.g. Cryocap™ H₂ increase H₂ production up to 20%)

DESCRIPTION

CRYOCAP™ H₂

Based on its extensive experience in hydrogen production units, Air Liquide has developed a technology capable of capturing the CO₂ emitted during hydrogen production (by SMR or ATR or POX). This proprietary technology is the subject of several patents and allows customers to make significant cost reductions.

On top of capturing and liquefying the CO₂ in one step, it is the only technology that can reduce CO₂ emissions during the production process while boosting hydrogen production by 13 to 20%. It has the lowest cost on the market for CO₂ capture in hydrogen production units (especially compared to activated MDEA), and can be adapted to existing and future hydrogen production units.

The technology uses cryogenic purification to separate the CO₂ from Pressure Swing Adsorption (PSA) offgas, containing typically 40-50%v CO₂. The PSA offgas is compressed, dried and sent to a cryogenic unit, where the CO₂ is separated from the other components by a combination of partial condensation and distillation. A pure and pressurized CO₂ flow is produced from the cold process. The non-condensed gases are recycled through a membrane system to recover H₂ and CO₂. Residual gas is sent to the burners of the H₂ production plant. The CO₂ product is compressed up to supercritical pressure or liquefied and stored in liquid storage. Liquid CO₂ can also be directly withdrawn from the cold process at marginal costs. The CO₂ can be then liquefied and purified to meet CO₂ specifications of local industrial markets (agri-food, water treatment, etc.) or transport systems for sequestration. Cryocap™ H₂ can be installed for greenfield and brownfield H₂ plants.

Key Figures:

- Capacity: from 300 - 10,000 tpd
- Hydrogen production: increase of 13 - 20%
- Avoided CO₂ cost reduction: up to 40% compared to MDEA
- OPEX + CAPEX: 30-50 €/tCO₂ captured
- Gaseous or liquid CO₂
- More than 99% of CO₂ and H₂ recovery from syngas

Main Applications:

- H₂ production (SMR or ATR), POx, any syngas with >15% CO₂

Reference / Project Examples:

- 2012 - Industrial CCU EPC for 300 tpd in France
- 2019 - Industrial CCS pre-FEED in EU (Air Liquide SMR)
- 2020 - Industrial CCS FEED in Belgium (Air Liquide SMR)
- 2021 - Award by Dutch SDE++ for Porthos project and by EU Innovation fund for Kairos@C project (both Air Liquide SMR)
- 2022 - Selection by US DOE for FEED in USA (Air Liquide SMR)
- 2022 - Industrial CCU EPC project in Grandpuits, France (with TotalEnergies)

CRYOCAP™ FG

Air Liquide developed a dedicated capture technology in order to address low-hanging fruits of the high-concentrated sources: industrial flue gases. Many high CO₂-emitting industries have concentrated sources of CO₂ emissions above 15%, such as hydrogen production with SMR, cement and lime production, blast furnaces in hot metal production, and FCC in refineries. These high-concentrated sources are estimated to represent around 50% of the global industrial direct emissions. Additionally, Cryocap™ FG can also significantly abate NOx emissions from flue gas and to deliver the on-spec liquid CO₂ product at its battery limits, thereby reducing the number of process units and interfaces, and increasing the level of overall optimization and reliability.

Cryocap™ FG is a separation process based on the combination of adsorption and cryogenic separation. The flue gas is first compressed, dried and sent to a PSA (Pressure Swing Adsorption). The PSA pre-concentrates the CO₂ in the offgas. It is compressed then sent to a cold process. There, the CO₂ is recovered by the combination of partial condensation and distillation, which allow the removal of various elements such as O₂, Ar, N₂, NO and CO. The CO₂ product is compressed, condensed and pumped up to supercritical pressure or directly produced as liquid. The pressurized nitrogen from the PSA is expanded to recover energy.

Key Figures:

- Capacity: 300 – 10,000 tpd
- PSA-assisted CO₂ condensation
- Compressors, PSA and cryo process can be located in two different plots
- Smart impurities management (high NOx)
- 40 to 80 €/tCO₂ captured
- Gaseous or liquid CO₂
- CO₂ capture rate: up to 98%

Main Applications:

- Flue gases or off gases with CO₂ content >= 15% (SMR, cement/lime, steel blast furnace, refineries (FCC), waste incineration/biomass power plant, pulp & paper)

Reference / Project Examples:

- 2020 - Industrial CCS Engineering Study for 2,000 tpd in EU (FCC)
- 2021 - Industrial CCS Process Design Package + License for 2400 tpd in EU (SMR)
- 2021 - Selection by US DOE for a FEED on largest single kiln for Holcim St. Genevieve plant in US (e.g. 10,000 tpd CO₂)
- 2022 - Two awards by EU Innovation Fund for FOIK cryogenic capture on lime flue gas (Lhoist Réty) and cement single line kiln (Lafarge Holcim Kujawy)
- 2022 - Two selections by US DOE for FEED on Gulf Coast SMR and a Direct Reduction Iron (DRI HBI) (Arcelormittal, previously Voestalpine)

CRYOCAP™ OXY

Cryocap™ Oxy uses oxy-fuel combustion exhaust as a feedstock. Its unique technological bricks include flue gas drying, dust filtration, and cryogenic purification. Through this technology, a high rate of CO₂ recovery is achieved, and can reduce atmospheric emissions from power plants to almost zero (emissions of NOx, SOx, fine particles and Hg).

The flue gas issued from the cement or lime or power plant is first treated in a pre-treatment unit, which aims to cool the gas and remove the SOx, HF, HCl, most of the NOx, and dust. Then, the gas is compressed and dried before entering the cryogenic purification unit. In the cold process, CO₂ is recovered by combination of partial condensation and distillation, which allows the removal of the heavy compounds such as NOx and the light elements such as O₂, Ar, N₂, NO and CO. The CO₂ product is compressed, condensed and pumped up to supercritical pressure or directly produced under liquid state.

Key Figures:

- Capacity: 1,000 and 15,000 tpd
- 30 - 50 €/tCO₂ captured
- Energy savings through residual gas
- Gaseous or liquid CO₂
- Enriched flue gas above 60% CO₂
- Smart impurities management (high NOx)
- CO₂ capture rate: 90-98%

Main Applications:

- Cement/Lime
- Power plant
- Any applications with CO₂ concentration >40%

Reference / Project Examples:

- 2008 - Demo CCS EP for 200 tpd in France (Total - oxyfuels)
- 2010 - Pilot CCS EP for 80 tpd in Australia (Callide)
- 2012 - Pilot CCS EPC for 200 tpd in Spain (CIUDEN)
- 2014 - Industrial CCS FEED for 3500 tpd in US (Futuregen)
- 2015 - Industrial CCS FEED for 1500 tpd in France (Lafarge - cement)
- 2021 - Awarded by Innovation Fund for ~1MTPY (EQIOM - cement)

CRYOCAP™ STEEL

This solution was designed to specifically capture CO₂ from steel making plants, with CO₂ stream concentrations of 20-50%. The gas is first compressed, dried and sent to a PSA (Pressure Swing Adsorption). The PSA pre-concentrates the CO₂ in the offgas while producing a CO rich stream.

The pre-concentrated CO₂ stream is compressed and sent to a cold process. There, the CO₂ is recovered by combination of partial condensation and distillation, which allows the removal of the light elements such as Ar, N₂, H₂ and CO₂. The CO₂ product can be produced as a gaseous or liquid product. The pressurized CO-rich stream is either recycled to the blast furnace or used to produce fuels.

Key Figures:

- Capacity: from 300 - 5,000+ tpd
- Compact and flexible footprint: compressors, PSA and cold-box can be located in three different plots
- 25-60 €/t CO₂ captured
- Gaseous or liquid CO₂
- CO₂ capture rate: 80 to 95%

Main Applications:

- Iron and Steel Production

Reference / Project Examples:

- 2005 - Pilot CCS EPC for 40 tpd (pre-concentration part) in Sweden (MEFOS)
- 2012 - Industrial CCS FEED for 3,600 tpd in France (ULCOS)
- 2019 - CCU for 800 tpd (pre-concentration part) in Belgium (Steelanol)

2020 - CCU LCO₂ Pre-FEED for 350 tpd in Korea

CRYOCAP™ NG

The CO₂ rich natural gas is first dried and sent to a cold process where the CO₂ is separated from the other components through a combination of partial condensation and distillation. High CO₂ partial pressure favors the partial condensation of CO₂ and therefore, makes its separation from natural gas even easier. The non-condensable gas is enriched in methane and sent to a membrane for final purification. The CO₂ purity of the product corresponds to pipeline specifications, generally 1 - 10 mol%. The CO₂-enriched permeate stream of the membrane is sent back to the cold process. The CO₂ and heavy hydrocarbons condense in the cold process and are collected at high pressure. NGL recovery is possible with almost no additional cost. Cryocap™ NG is tolerant to some content of H₂S. Cryocap™ NG also allows for bulk removal of H₂S from NG.

Key Figures:

- Up to 1,000,000 Nm³/h
- Separation cost: less than 1 USD/MMBTU
- Capex savings: > 50% vs. amine absorption (at high CO₂ content)

Main Applications:

- Natural gas with high CO₂ content (>35%)



AMINE SOLUTIONS, RECTISOL™, AND RECTICAP™ AIR LIQUIDE

SUMMARY

Air Liquide engineers solvent based technologies such as amine to capture CO₂ from synthesis gas or flue gas. Through long term partnerships with the key amine license providers, Air Liquide has installed 80+ units and benefits from its long-term operational experience of amine units.

Considered as the industrial base case, amine technology can deliver high purity gaseous CO₂ (99+%) at low

pressure, which can be combined with Cryocap™ XLL. For CO₂ capture on flue gases with low CO₂ concentration (below 10%), amine technology remains the most competitive solution, provided the availability of large amounts of excess steam or high grade heat. Air Liquide is also offering proprietary technologies for CO₂ capture from synthesis gas (Rectisol™, Recticap™).

| | | ABSORPTION TECHNOLOGIES | | | |
|---------|--|-------------------------------------|---------------|--|--------------|
| Technos | | AMINE WASH | FG AMINE WASH | RECTICAP™ | RECTISOL™ |
| | | Heat driven CO ₂ removal | | High efficiency - adapted to large scale low carbon hydrogen | |
| Source | | Syngas | Flue Gas | H ₂ Production | Gasification |

BENEFITS

- Fully referenced in all applicable scales and different applications
- Process uses inexpensive, available and chemically stable solvent
- Technology provides low operating costs and high availability
- Process configuration can be tailored to optimize CAPEX and OPEX figures

DESCRIPTION

ACID GAS REMOVAL – AMINE WASH

The process configuration and solvent selection will be tailored according to feedstock and sweet gas application. Air Liquide can offer very energy-efficient processes such as the BASF OASE® purple or OASE® yellow as well as other proprietary or generic amines for pipeline or liquefied natural gas specifications. This process presents the advantage of very low hydrocarbon co-absorption. With selective processes, deep H₂S removal with low to moderate CO₂ co-absorption can be achieved for pipeline specifications. Capacity is up to 1,500,000 Nm³/h per train.

CO₂ REMOVAL FROM FLUE GAS (3-25% CO₂) - AMINE WASH

Air Liquide offers energy efficient solutions with highly stable, low maintenance solvents based on proprietary second generation amines. CO₂ capture rates of up to 97% can be reached irrespective of the feed's CO₂ content, and CO₂ product specifications of up to >99.9%. Capacity Up to 1,500,000 Nm³/h feed per train, up to 4,000 tpd CO₂ per train. Trace components such as particles and SO_x are handled in the upstream pretreatment.

Key Figures:

- 99.7% availability
- Max 16% O₂ in flue gas
- Range: min 150 tpd CO₂ - max 4000 tpd CO₂
- Capture rate: 85 to 97%
- CO₂ up to 2.5 bara w/o compression
- CO₂ purity up to 99.9%
- Particles & SO_x handled upstream of amine wash
- Low electrical power consumption

Main Applications:

- Flue gases or off gasses from industrial sources with CO₂ content 3% to 25% - (SMR, cement/lime, steel blast furnace, refineries (FCC), biomass power plant, pulp & paper)

Reference / Project Examples:

- 5 units in operation, 6 OASE Blue references from BASF

CO₂ REMOVAL FROM SYNGAS - AMINE WASH

Air Liquide offers highly energy-efficient processes such as BASF OASE® white. The process configuration will be tailored according to treated gas requirements and CO₂ product specification as well as optimized CAPEX and OPEX. The process can be heat-integrated with the upstream gas generation. CO₂ specifications in the treated gas < 20 ppm are achievable, making this process ideal for CO₂ removal upstream of any coldbox or ammonia process. CO₂ capture rates from syngas of >99% can be achieved to produce a decarbonized hydrogen product. Since the process has a very low co-absorption even at higher feed gas pressures, CO₂ product specifications with CO₂ > 99% are achievable.

Key Figures:

- 99.7% availability
- Capacity: from 100 - 3500 tpd CO₂
- Capture rate up to 99.9% on feed gas
- Spec: up to 50ppm CO₂ in treated gas
- CO₂ at ~1.2 bara, purity of up to 99.3%
- Low electrical power consumption
- Solvent regeneration is done using heat, with possible heat integration with existing hydrogen plant

Main Applications:

- H₂ production (SMR, POX, ATR)
- Syngas with ~15% to 20% CO₂. Oxo-syngas with 5% to 15% CO₂

Reference / Project Examples:

- 30 OASE references, 80 amine wash units in total

RECTISOL™

Harmful acid gases contained in raw gases from any gasification are removed by absorption with a physical solvent (cold methanol). Rectisol™ is the leading process when it comes to the purification of gasification-based syngas for catalytic applications (production of syngas, methanol, ammonia, or Fischer-Tropsch) as well as hydrogen and syngas for power production. Using inexpensive solvent in combination with optimized heat integration, the Rectisol™ process has extremely low operating costs and high availability.

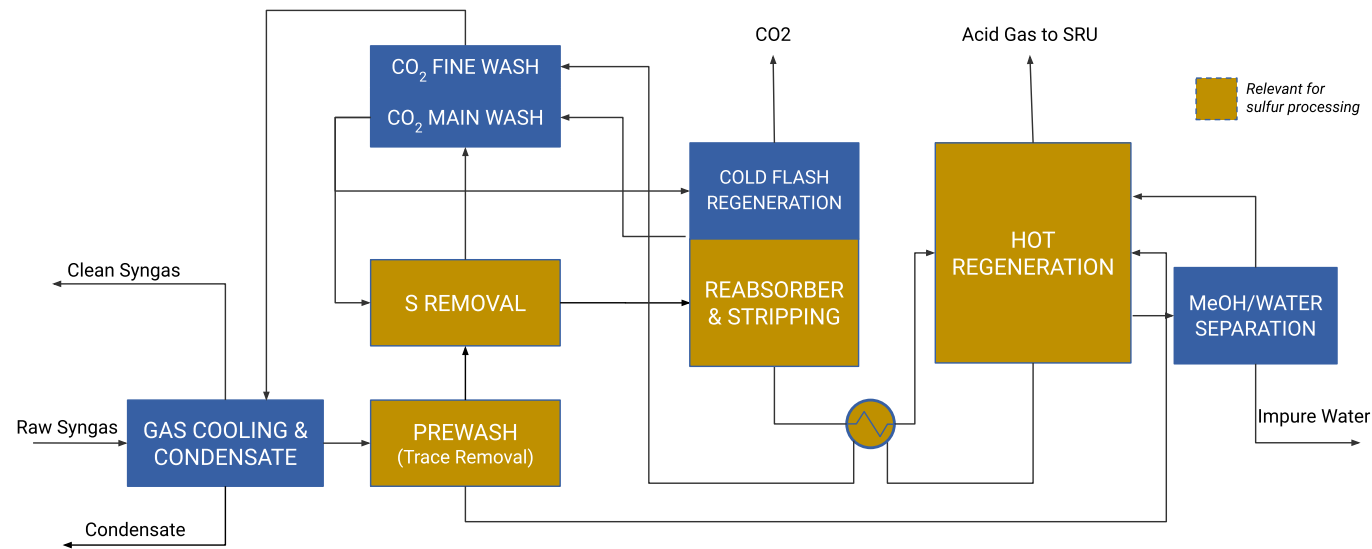

Key Figures

- 50,000 - 1,000,000 Nm³/hr per train (feed gas)
- H₂S + COS removal rate < 0.08 ppm
- CO₂ removal rate up to 5-50 ppm
- Special setups for removal of mercaptans, metal carbonyls and BTX available
- Accumulation of all harmful contaminants within the acid gas to be safely processed in a SRU
- An additional compressor can be added to increase capture rate

Main Applications:

- H₂, Methanol production, Sustainable Aviation Fuels

Reference / Project Examples:

- + 30 References

RECTICAP™

Recticap™ is an optimized Rectisol™ concept tailored for energy transition projects focused on ATR based low-carbon H₂ to produce low cost low-carbon hydrogen in large capacities (>300,000 kNm³/hr) at moderate to high pressures (>25 bar). In contrast to a Rectisol™, Recticap™ removes only CO₂ from the raw hydrogen/ syngas and has hence a simplified process setup with reduced capital expenditures. The solution allows up to 98% CO₂ capture from syngas. Dry CO₂ capture-ready at >98.5% purity is achievable.

Recticap Benefits

- Optimized solution for sulfur-free syngases
- Targeting large single train ATR based H₂ application in energy transition projects
- Process simplification due to clean syngas and CO₂ capture only
- Up to 50% lower CAPEX and 25% lower OPEX for same syngas volumes than Rectisol™
- Know-how from AL's own operated plants and Rectisol™ demonstration unit

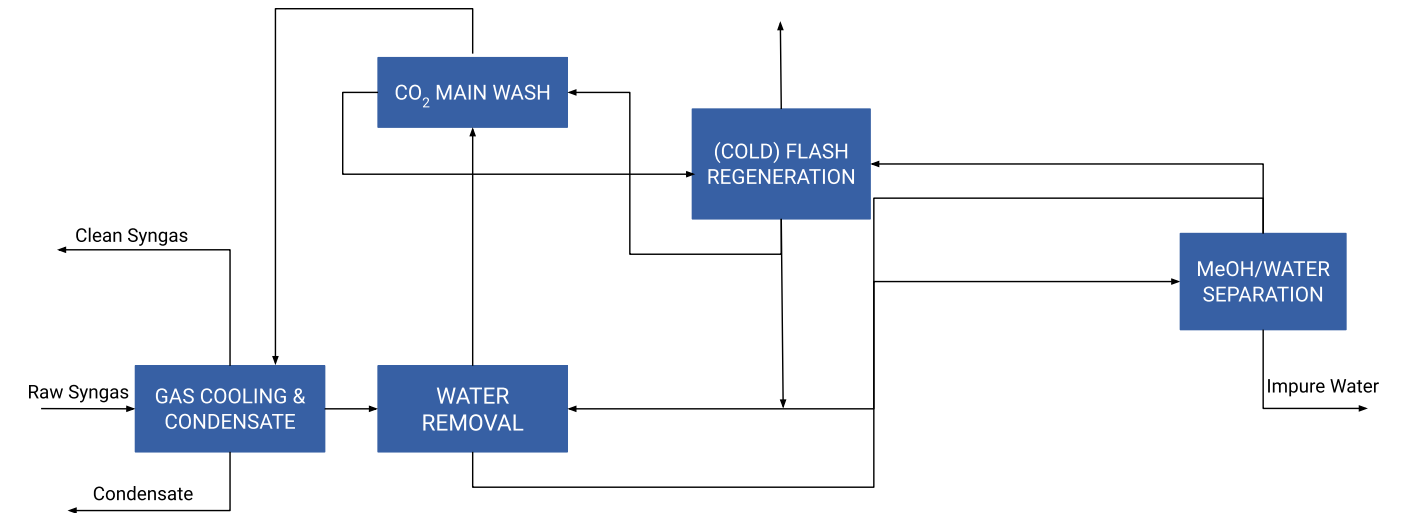



CRYOCAP™ XLL (LARGE CO₂ LIQUEFACTION) AIR LIQUIDE

SUMMARY

Air Liquide has developed Cryocap™ XLL, specifically designed to liquefy large volumes of CO₂. The solution allows aggregation of CO₂ from various emitters utilizing possibly different types of carbon capture technologies. On top of liquefying CO₂, Cryocap™ XLL also allows the removal of moisture and other compounds (such as O₂) to meet CO₂ sink specifications. The technology has been developed for large scale and is able to reduce specific power for CO₂ liquefaction by 40% compared to existing small scale CO₂ liquefier used for industrial merchant applications.

BENEFITS

- HSE-Friendly
- Custom plant: flexible design
- Moisture and other light compounds (O₂, N₂...) removal
- High compactness
- Low specific energy
- Cost efficiency

The technology is especially suited for CO₂ industrial hubs and basins where the CO₂ needs to be transported via ships, trucks, or trains. Cryocap™ XLL is a HSE-friendly solution that does not involve the use of any toxic or flammable external refrigerant (such as propane). As a single compressor is used for both the feed and the cycle, it is also a very compact and cost effective solution.

DESCRIPTION

The Cryocap™ XLL process is proposed as an industrial solution to compress, liquefy, and purify the raw CO₂ stream resulting from upstream units. The CO₂ feed gas is compressed in the feed/recycle compressor, dried at an intermediate pressure and then compressed again. The compressed gas is cooled down and then routed to the cold process. In the cold process, the high-pressure, dry CO₂ is cooled down and split into various streams. One of these streams is purified by distillation in the Stripping Column to produce the liquid CO₂ product, which is routed to the unit's battery limits. The remaining streams are expanded to different levels and vaporized in the main heat exchanger, providing the refrigeration load required for the liquefaction of the CO₂. Once vaporized, these streams are recycled at ambient temperature to the feed/recycle compressor. This configuration makes it possible to handle the compression of the feed gas and the refrigeration with a single compressor (so called self-refrigerated cycle).

Key Figures:

- 800 to 10,000+ tpd
- Custom plant: flexible design
- Liquefies CO₂ at ambient temperature
- 5-25€/tonne CO₂ liquefied
- Very low OPEX: 30-130 kWh/tonne CO₂
- HSE-friendly (CO₂ cycle)

Reference Examples:

- Design for 4 x 7000 tpd in Belgium (Antwerp@C)
- FEED in Dunkirk, France (DARTAGNAN) - Awarded CEF Funding

LONGSTANDING EXPERIENCE IN CO₂ MANAGEMENT

Air Liquide has a longstanding experience in CO₂ management, from capture, purification and liquefaction to storage and transport from various sources. Air Liquide can also upgrade the recovered CO₂ and provide it to various markets, such as the agri-food industry (carbonation, preservation, and refrigerated transport), water treatment, chemicals...

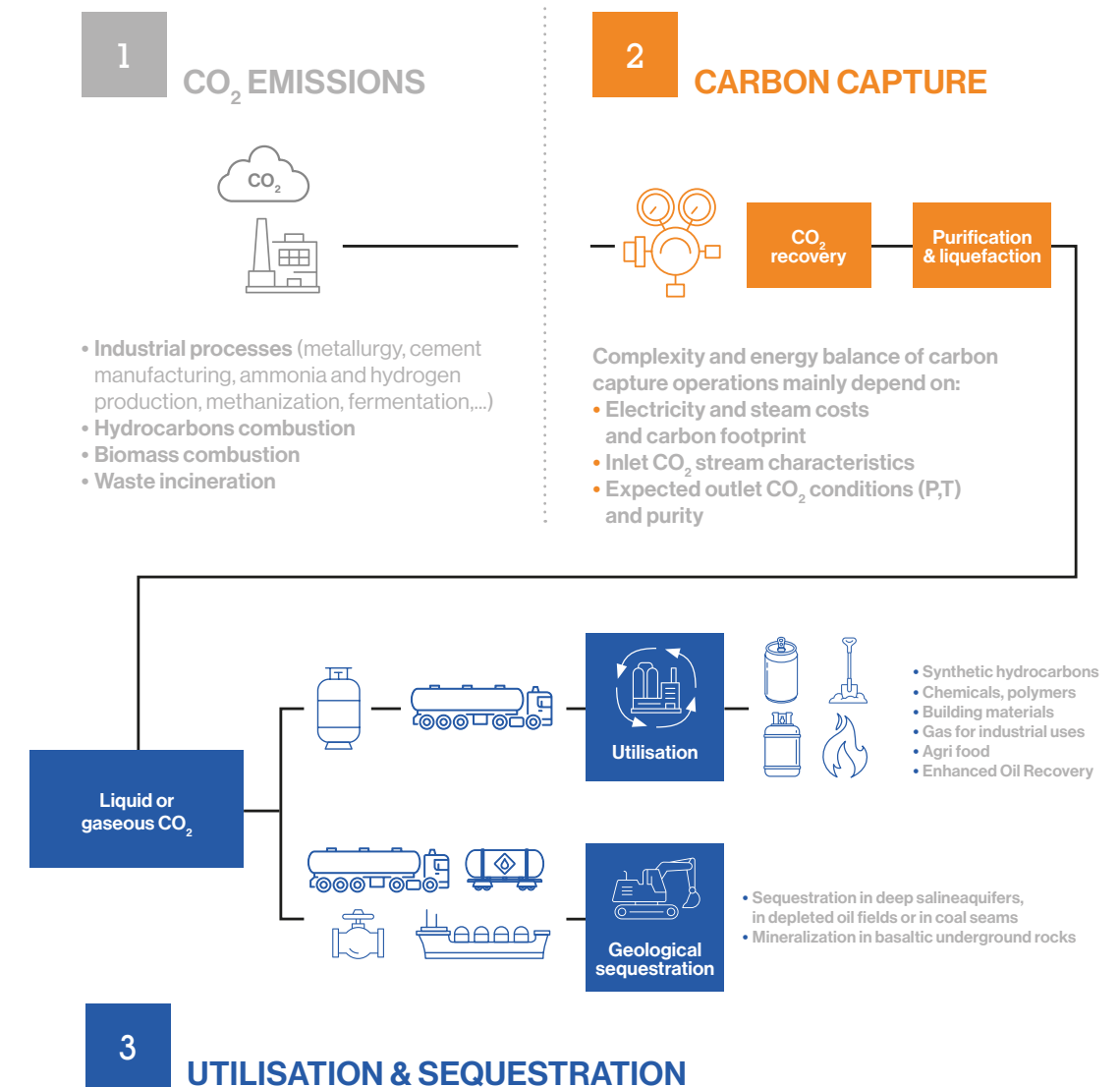



ADVANCED AKER CARBON CAPTURE (ACC™) AKER CARBON CAPTURE

SUMMARY

Aker Carbon Capture is a pure-play carbon capture company with solutions, services and technologies serving a range of industries. The company has proprietary and field-proven technology to enable carbon emission reduction and removal in sectors such as cement, gas-to-power, biomass and waste-to-energy, blue hydrogen, and other hard-to-abate industries. Aker Carbon Capture's Advanced Carbon Capture (ACC™) technology has been continuously developed since 2005 and offered commercially since 2009.

The company's business model covers the sale of complete carbon capture units, license models including supply of key equipment, aftermarket services and,

together with industrial partners, a full value chain Carbon Capture as a Service model. In general, Aker Carbon Capture's plants include a high degree of modularity in their designs, which is an important driver to reduce costs and shorten delivery times.

We deeply believe partnerships are crucial to grow the CCUS industry, such as the unique partnership we have with Microsoft to pursue joint innovation and services to accelerate the deployment of carbon capture. Aker Carbon Capture's overall purpose is to accelerate planet positive by enabling carbon reduction and removal from industries and energy solutions.

BENEFITS

- Highly energy-efficient capture process with innovative heat integration solutions.
- Includes proprietary ACC™ advanced emission control system to prevent the formation of amine mist, which nearly eliminates the emissions of amine and amine degradation products.
- Verified via 60,000 hours of data for operating on flue gas from cement kilns, waste-to-energy plants, gas power plants, hydrogen production, char production, smelting and refinery applications, through campaigns with our Mobile Test Unit and at Technology Centre Mongstad.

- Aker Carbon Capture's ACC™ CO₂ capture process, including CO₂ liquefaction, intermediate storage and CO₂ export has been qualified by DNV-GL according to DNV-RP-A203 Qualification Procedures for New Technology and DNV-RP-J201 Qualification Procedures for CO₂ Capture Technology.
- Includes extremely robust solvents for environmentally friendly operations. The proprietary ACC™ solvents are characterized by low solvent degradation, which is associated with a low corrosion rate in the plant, low amine makeup requirement, low emissions of amine degradation products, low demand for amine reclamation, and thereby, resulting in low production of reclaimer waste.

DESCRIPTION

PROPRIETARY AND PROVEN TECHNOLOGY

The technology behind the company's business has robust patent protection and offers best-in-class Health, Safety and Environment (HSE) characteristics, along with high energy efficiency. It can be applied to both existing and new build plants, and has extensive real-world validation, with 60,000 hours of operation to date across a range of carbon emitting industries. Aker Carbon Capture considers research, innovation, and technology development to be key drivers of competitive advantage. The company has an active program focused on reducing costs, developing and qualifying new carbon capture technologies, and improving carbon capture project economics. This includes capture efficiency, further modularization, and the implementation of digital capabilities.

The ACC™ proprietary solvents were developed in an eight-year comprehensive R&D program (SOLvit) together with industry players and Norwegian research partners. Numerous solvent mixtures were tested and compared regarding energy consumption, robustness, toxicity, material compatibility, and – most importantly – HSE performance. The SOLvit program resulted in energy-efficient solvents, with no negative environmental impact or occupational hazards. This results in reduced solvent consumption, meaning reduced OPEX. Compared to traditional amines our proprietary amines also minimize degradation products, which can have a significant impact on corrosion and the need for maintenance".

The ACC™ capture technology including the ACC™ solvents and ACC™ Emission System has been tested and verified on flue gases from gas-fired and coal-fired power plants, cement kilns, waste-to-energy plants, hydrogen production plants, char manufacture and smelting, with 60,000 hours of operating experience from the US, Germany, Scotland, Sweden, Poland, and Norway. Based on the extensive testing, the ACC™ capture technology is qualified by DNV GL according to DNV-RP-A203 Qualification Procedures for New Technology and DNV-RP-J201 Qualification Procedures for CO₂ Capture Technology.

Energy optimization is critical for the successful implementation of carbon capture as it significantly reduces the energy consumption of the process. At Aker Carbon Capture, energy optimization, heat integration, and waste heat recovery are prioritized focus areas. Aker Carbon Capture offers several highly effective solutions for energy optimization, tailored to specific industrial applications and site-specific conditions. The recommended solution is based on the overall energy performance of the parent and the capture plants.

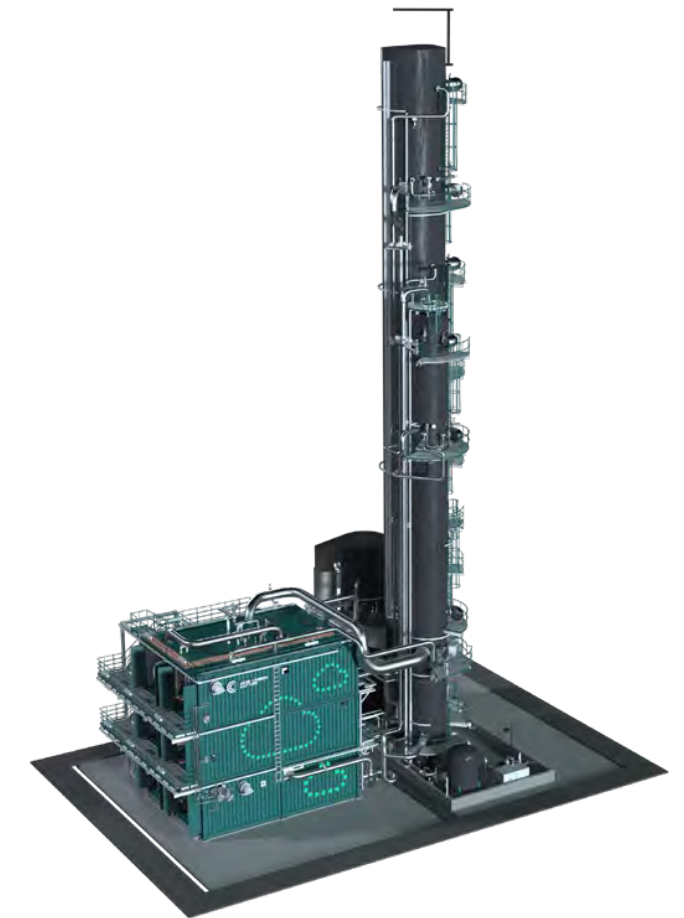

Aker Carbon Capture's Just Catch™

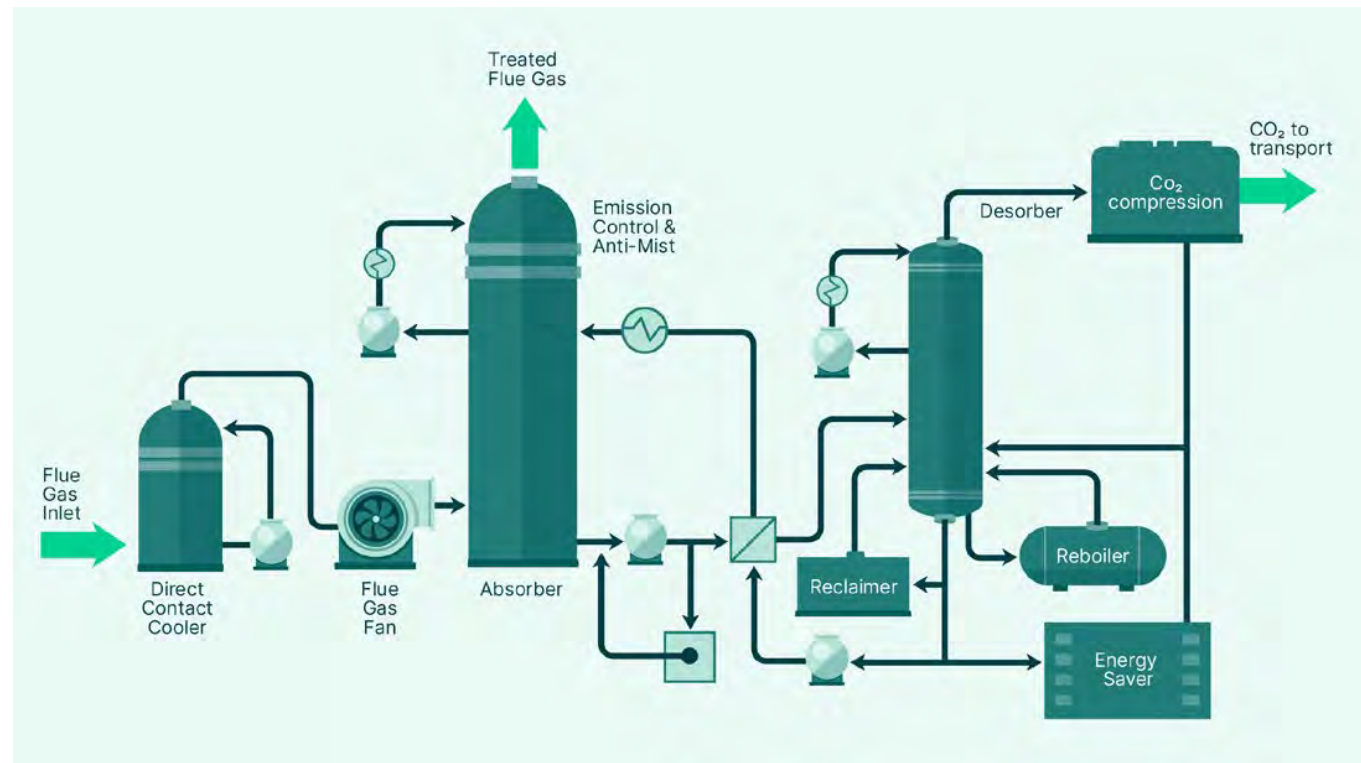

Aker Carbon Capture's Advanced Carbon Capture (ACC™)

The main unit operations of the ACC™ process include the Direct Contact Cooler (DCC), the absorber, and the desorber columns, the reboiler, the reclaimer, the energy saver, the flue gas fan, and a liquefaction unit with an optional proprietary advance heat integration.

Flue gas from the client's plant is extracted downstream of any existing flue gas emission control units through the flue gas fan. The flue gas is pre-treated in the DCC. The purpose of the DCC is to cool the flue gas and to remove any acid gases, such as SO₂, HCl, and HF. Condensed water from the flue gas will exit the DCC as a bleed stream.

Flue gas from the DCC is routed to the CO₂ absorber downstream of the booster fan. The CO₂ absorber consists of a CO₂ absorption section in the lower part of the column and a water wash section with an emission control system in the upper part of the column. In the absorption section, flue gas contacts the lean amine solvent in a countercurrent flow regime, absorbing CO₂ from the flue gas. Continuing to the upper part of the column, the emission control system including the ACC™ Anti-Mist design cools and cleans the CO₂-lean flue gas of traces of amines and potential amine degradation products, thus effectively preventing emissions of amine and potential amine-degradation products in the form of aerosols. CO₂-lean flue gas is either emitted from the absorber stack or returned to the existing flue gas stack downstream of the flue gas extraction point.

CO₂-rich amine is drained from the absorber sump. The rich amine solvent is regenerated using steam. The steam is condensed in a reboiler and returned to the battery limits as hot condensate. The increase in temperature during the indirect heating of rich solvent with steam strips the CO₂ out of the solvent. The resulting lean amine is returned to the absorber for reuse in the CO₂ capture process, while the CO₂ exits the top of the desorber. The energy saver consists of a proprietary process that reduces the steam consumption in the reboiler.

CO₂ may be compressed and e.g., fed into a regional CO₂ pipeline to be transported to permanent storage, or compressed and liquified for transport by ship or truck. The ACC proprietary technology solution enables internal heat recovery from compression that also reduces the overall steam requirement for the carbon capture plant.

To maintain high solvent performance, a reclaimer is included to intermittently remove impurities and degradation products from the amine solvent. A small amount of concentrated liquid waste is generated in the reclaimer. This reclaimer waste needs to be disposed of batch-wise as chemical waste. Due to the low degradation rate of the ACC™ solvents, along with a properly designed DCC, the amount of reclaimer waste from the ACC™ process is very low compared to standard plants operating with generic solvents such as MEA.

REFERENCE PROJECTS

Technology Center Mongstad (TCM)

Aker Carbon Capture designed and was awarded the EPC delivery of the carbon capture test facility plant at TCM. This full-scale CO₂ capture plant captures CO₂ from the gas-fired combined heat and power plant and the catalytic cracker at the Mongstad refinery in Norway. Different from competitors, Aker Carbon Capture has not only tested our ACC™ technology at the TCM facility but designed and delivered the actual plant, which has been in continuous operations since 2012.

Customer: Statoil (now Equinor).

Twence CCU

This first-of-a-kind project will enable the removal of CO₂ from flue gases at Twence's waste-to-energy installation facility located at Hengelo, the Netherlands. The captured and liquified CO₂ will be used primarily by greenhouses in the horticultural sector, where it will enhance crop growth. The delivery is planned to take place at the end of 2023.

CO₂ capture capacity: 0.1 Mtpa

Brevik CCS

Aker Carbon Capture has been working together with Heidelberg Materials Sement Norge and partners in developing a full-scale CO₂ capture, conditioning, compression, heat integration, intermediate storage and loading facility for their cement plant at Brevik in Norway. CO₂ is being captured from the flue gases of the cement kiln using waste heat recovered from the cement plant and the CO₂ compression plant through a proprietary heat integration technology. The ACC™ capture plant will be the world's first large-scale CO₂ capture plant at a cement plant, and is planned to be delivered in 2024. Brevik CCS is part of the Norwegian Longship Project.

CO₂ capture capacity: 0.4 Mtpa

Ørsted Kalundborg Hub

Aker Carbon Capture will deliver five Just Catch™ units, which will be delivered to Ørsted's wood chip-fired Asnæs Power Station and the Avedøre Power Station's straw-fired boiler. Combined, these facilities will have an installed design capture capacity of 500,000 tonnes CO₂ per year. Expected delivery will be in 2025.



Twence CCU (Copyright)



CONTACT

Email: marketing@babcock.com

Web: www.babcock.com



CLIMATEBRIGHT™ DECARBONIZATION TECHNOLOGIES BABCOCK & WILCOX

SUMMARY

The ClimateBright™ suite of revolutionary hydrogen and decarbonization technologies from Babcock & Wilcox (B&W) is designed to help customers in energy and industrial sectors aggressively combat greenhouse gas emissions and climate change. ClimateBright technologies further strengthen B&W's commitment to clean energy progress and to helping customers worldwide address the most significant environmental challenges in industrial processes and energy generation.

ClimateBright has a wide range of clean energy solutions to drive the energy transition through capture carbon and production of hydrogen for industries including energy production, food manufacturing, steel, cement, oil and gas, pharmaceutical, petrochemical, carbon black, and pulp and paper. Our technologies build on B&W's core talents in steam generation, combustion, and flue gas treatment, and

each addresses the emissions of CO₂ from the combustion of carbon-based fuels in a unique way:

1. BrightLoop™ uses a chemical looping process around a ferrous oxygen carrier to separate the products of combustion of a carbon-based fuel into separate streams of CO₂ and oxygen depleted air, allowing for the capture of CO₂.
2. SolveBright™ is a post combustion capture process using regenerable solvents.
3. OxyBright™ purifies the flue gas stream to near pure CO₂, simplifying its capture.
4. BrightGen™ eliminates the generation of CO₂ by switching to a non-carbon-based fuel.
5. Flue gas pre-treatment for post-combustion CO₂ capture.

DESCRIPTION



BRIGHTLOOP™ CHEMICAL LOOPING

Babcock & Wilcox partnered with The Ohio State University to develop our BrightLoop chemical looping technology, which can use a variety of fuel stocks to produce hydrogen, syngas, steam, liquid fuel or methanol, and/or power while also producing a stream of concentrated CO₂ for sequestration and storage or other uses.

The patented BrightLoop process is based on the oxidation and reduction of an iron-based oxygen carrier particle and has the ability to capture a pure stream of hydrogen and CO₂ from gas and solid fuels – including biomass, coal, waste fuels, natural gas, biogas, petroleum coke (petcoke) or others. In this process, fuel reacts with the oxygen-carrier particles in a reducer reactor (fuel reactor), forming combustion byproducts, predominantly CO₂, while reducing the oxygen-carrier particles. The reduced oxygen-carrier particles then move to a partial oxidizer (hydrogen reactor) where they react with steam to partially oxidize the particles and generate a stream of hydrogen.

The oxygen-carrier particles are then transported to a combustor reactor (air reactor) where they are regenerated with air back to their original state. The fuel and hydrogen reactors use moving bed technology while the air reactor uses fluidized-bed technology, both well-proven technologies with which B&W has extensive experience. Other emissions can be controlled using B&W's complete suite of environmental control technologies.

We are confident our BrightLoop technology will play a major role in helping the world transition to a more sustainable future, supporting the international goal of net-zero greenhouse gas emissions by 2050.



SOLVEBRIGHT™ POST-COMBUSTION CO₂ SCRUBBING

B&W's SolveBright regenerable solvent absorption technology scrubbing process came from decades of decarbonization research and development. The SolveBright carbon dioxide scrubbing system is a post-combustion carbon capture technology that captures CO₂ directly from flue gas in an absorber using a regenerable solvent. The CO₂-laden solvent is sent to a regenerator where it is heated, and the CO₂ is released as a concentrated stream for compression and storage or beneficial uses. The solvent is then recycled to the absorber for reuse.

While B&W's solvent demonstrated superior performance compared to more than 100 competing solvents during our extensive testing procedures at the National Carbon Capture Center, a major advantage of the SolveBright process is solvent flexibility, which allows customization of an optimal CAPEX and OPEX solution for each application. SolveBright can be used with a variety of solvents and we have the expertise and ability to use a wide range of potential solvents.

B&W has extensive knowledge of combustion processes – including many decades of experience with waste-to-energy and biomass-to-energy plants – and thermal management associated with combined heat and power systems and can effectively integrate the carbon capture system into an existing facility. This experience gives us the ability to optimally integrate the SolveBright solution with virtually any new or existing facility.

B&W's solvent-based CO₂ capture experience spans a wide range of industries with various fuels and we can offer total solution support -- from feasibility studies, pre-FEED and pilot unit definition, to full-scale plants -- tailored to the customer's specific needs.





OXYBRIGHT™ OXY-FUEL COMBUSTION - ADVANCED CARBON CAPTURE TECHNOLOGY FOR STEAM GENERATION

B&W's oxy-combustion process can be used to generate steam and power using a variety of fuels, including coal, natural gas, biomass, oil and others. In the oxy-fuel process, combustion air is replaced with nearly pure oxygen and recirculated CO₂. Nitrogen that would normally be conveyed with the air through conventional air-fuel firing is excluded and the resulting flue gas consists of nearly pure CO₂. The non-recirculated flue gas leaving the boiler is cleaned using conventional particulate and sulfur removal systems and sent to the compression purification unit (CPU) where a high-purity CO₂ stream is produced that is suitable for transportation or other uses.

B&W provided oxy-fuel technology for use with coal on the U.S. Department of Energy's FutureGen 2.0 demonstration project in Illinois, which was to be a retrofit of a 167-megawatt coal-fired power plant. Although construction began in 2014, the project was canceled in 2016 due to redirection of DOE funding support. B&W has continued to develop oxy-fuel technology and it is ready for full-scale commercialization and deployment.

In March 2022, B&W announced its OxyBright and biomass boiler-fired technologies would be part of the world's largest net-negative CO₂ biomass-to-energy facility to be developed by Fidelis New Energy at the Port of Great Baton Rouge, Louisiana. Using B&W's proprietary BrightLoop™ technology, the plant will be designed to turn biomass into low-carbon intensity hydrogen more efficiently and affordably than any other processes, spurring the production of 15 tons of it every day.

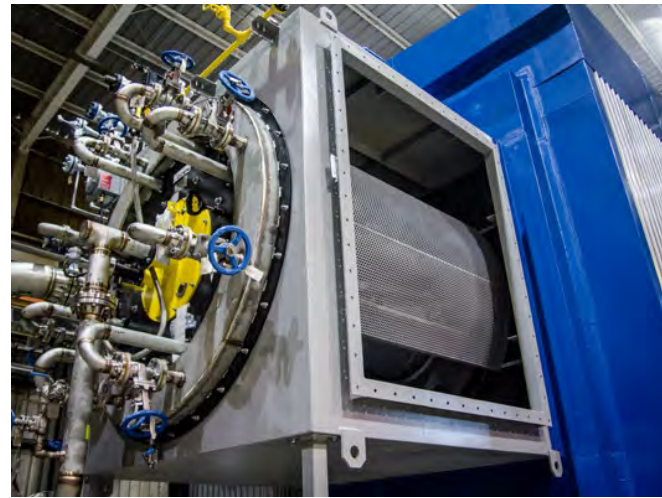

BRIGHTGEN™ HYDROGEN COMBUSTION

B&W's BrightGen hydrogen combustion solution is currently in operation at multiple refineries and industrial facilities around the world and is available to customers seeking a powerful hydrogen combustion solution for utility and industrial applications where efficient, zero-carbon dioxide-emissions energy generation is a goal.

Our highly reliable utility, industrial and FM package boilers can be manufactured or retrofitted with BrightGen technology to safely burn hydrogen or hydrogen-blended fuels for virtually any need, including power, heating and steam generation, and for industrial applications such as refineries and petrochemical facilities.

When considering the potential for fuel switching from a solid or gaseous fuel, and integrating hydrogen into the combustion process, B&W conducts a complete evaluation of the entire boiler system. This includes all combustion equipment such as burners, ignitors, flame scanners and fuel trains.

Our BrightGen technology is currently in use in more than 60 industrial boilers around the world.



FLUE GAS PRE-TREATMENT FOR POST-COMBUSTION CO₂ CAPTURE

Acid gases degrade the solvents used in a post-combustion carbon capture system. B&W offers a complete suite of environmental control technologies to control sulfur dioxide (SO₂), sulfur trioxide (SO₃) – which can form aerosols and cause loss of CO₂ capture solvents - hydrogen chloride (HCl), and hydrogen fluoride (HF) in the pre-capture flue gas stream, as well as technologies for other pollutants such as metals and particulates. Nitrogen oxides (NO_x) are also detrimental for CO₂ capture solvents and can lead to hazardous degradation products in the process. CO₂ scrubbing may also improve when particulate matter is removed from the flue gas prior to the scrubbing process.

B&W has many decades of experience in emissions control solutions, pioneering technologies that have helped customers comply with stringent emissions regulations for more than 50 years.

Our solutions include:

- Wet flue gas desulfurization (FGD) scrubbers
- Wet gas scrubbers (WGS)
- Spray dryer absorbers (SDA)
- Circulating dry scrubbers (CDS)
- Dry sorbent injection (DSI)
- Wet and dry electrostatic precipitators (ESP)
- Fabric filter baghouses
- Direct contact coolers (DCC)

SUMMARY

B&W has a broad range of unique and innovative technologies and processes for carbon capture, hydrogen generation and hydrogen combustion, including:

- CO₂ Removal – Capture (OxyBright, SolveBright, BrightLoop) Direct Carbon Removal CDR (DAC)
- CO₂ Reduction – Efficiency improvements and fuel mixing (CH₄ + H₂ – coal + biomass)
- CO₂ Avoidance – Replacing carbon-intensive power generation with renewables (green steam, LDES, solar) or fuel switching and combustion of hydrogen or ammonia – (BrightGen, electrolyzers, BrightLoop)
- CO₂ Reuse – Capture carbon for beneficial use – P2X (biogenic CO₂), food & beverage use (OxyBright, SolveBright, BrightLoop)
- CO₂ Storage – Capture and store (OxyBright, SolveBright, BrightLoop)
- Low Carbon Intensity Hydrogen Generation – (BrightLoop, electrolyzers)
- Hydrogen Combustion (BrightGen)
- Flue Gas Pre-Treatment (full suite of B&W environmental technologies)

More information on B&W's ClimateBright suite of products is available at www.babcock.com.

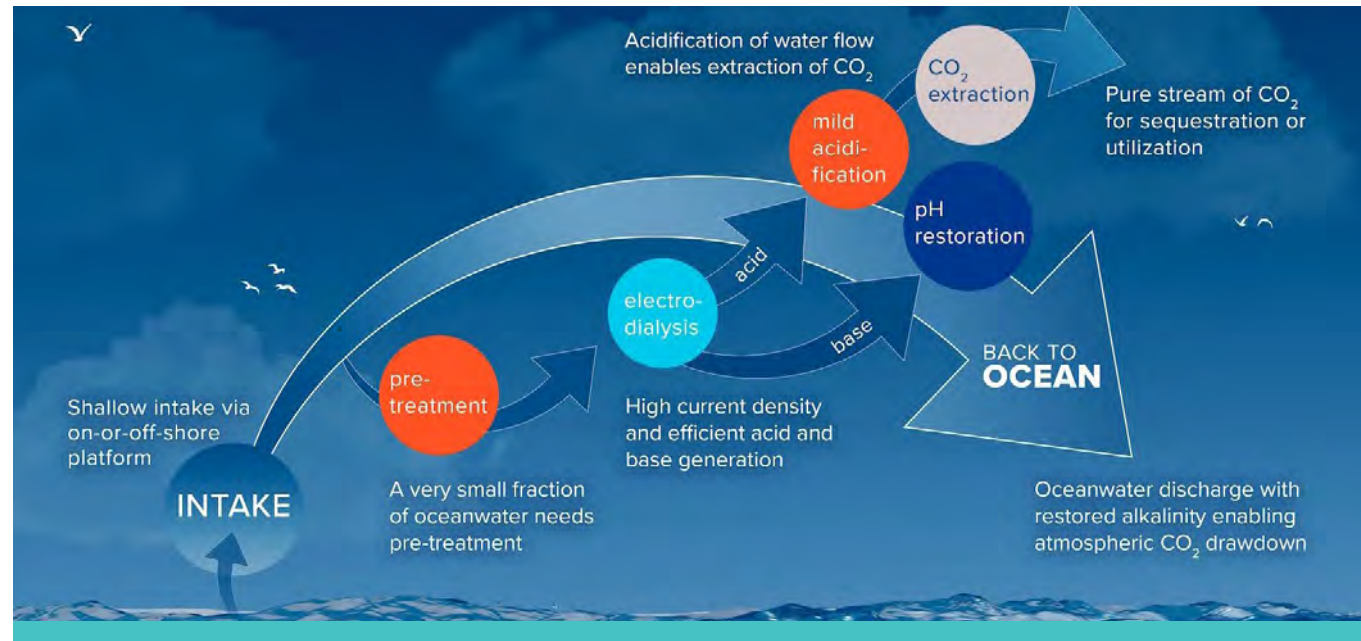

DIRECT OCEAN CAPTURE CAPTURA

SUMMARY

The planet's oceans are carbon removal powerhouses working hard to combat climate change, absorbing ~30% of all emissions we release into the air. However, this comes at the cost of ocean acidification. As the added CO₂ concentration grows, seawater becomes increasingly acidic, threatening the health of ocean life and marine ecosystems.

Captura has developed a Direct Ocean Capture approach that harnesses the carbon removal powers of oceans without contributing to ocean acidification.

Captura offers safe, scalable, and verifiable low-cost atmospheric carbon removal by leveraging the world's largest, existing, natural and no-cost atmospheric CO₂ absorber – the ocean. With minimal to no impacts on the environment and using only renewable electricity and seawater as inputs, Captura's technology generates a stream of CO₂ that can then be sequestered or utilized to make low-carbon products.

With no purpose-built air contactors, no absorbents, and no by-products, Captura's solution enables large-scale carbon removal at a lower cost.

BENEFITS

- **Low Cost:** Captura's technology provides savings in capital and operation compared to many other carbon removal technologies. No purpose-built air contactors or absorbents, lower energy requirement, widespread use of standard industrial equipment, lack of by-products requiring disposal and the ability to leverage off-peak renewable electricity inherently lowers costs.
- **Scalability:** Captura's use of the ocean, which covers ~70% of the planet, means the technology is deployable virtually anywhere there is ocean globally. Captura does not require any precious or rare-Earth elements as inputs, avoiding supply chain constraints that affect a broad range of clean energy technologies. Large increases in scale of our process only require minimal adjustments to our system rather than replications of multiple parts (as in modular approaches), making capacity growth highly accessible.

- **Ocean Health:** Captura's approach does not add anything, such as alkaline substances, to the ocean. Our process returns CO₂-depleted seawater with a slightly lower acidity to the ocean, which is quickly dispersed. Both this effluent and the placement of our technology in semi-enclosed areas, such as bays and coral reefs, can help to address ocean acidification.
- **Utilization:** The Captura process produces a measurable and verifiable stream of CO₂ to generate high-quality carbon credits. The CO₂ can also be used in the production of low-carbon products.

DESCRIPTION

Captura's approach is to remove CO₂ from the ocean to effectively 'make room' for the ocean to then draw down additional CO₂ from the atmosphere. The technology features a flow of seawater passing through the plant, which is treated to remove its CO₂ content before it is returned to the ocean.

When the decarbonized seawater is released back into the ocean, an equivalent quantity of atmospheric CO₂ will be drawn down as the surface ocean and atmosphere re-equilibrates. As wind and wave patterns facilitate mixing of the surface layer of the ocean, when plants are optimally located, atmospheric CO₂ is pulled down into the ocean to replace the same amount of CO₂ that the Captura system originally removed. In this way, for every ton of CO₂ Captura systems remove from seawater, the ocean removes a ton of CO₂ from the atmosphere.

The Captura process begins by pulling a stream of filtered seawater into the system. Around 0.5% of this water is diverted and pre-processed to purify it into brine. Captura's proprietary electro-dialysis technology then dissociates the salt and water in the brine into an acid and alkali base. This acid is added to the original flow of seawater, triggering a chemical reaction that draws the CO₂ out. The process

is accelerated using a gas-liquid contactor and vacuum pump. The CO₂ is captured as a gas stream, ready for subsequent sequestration or utilization. This leaves a flow of acidic, decarbonized seawater in the system. The alkali base is re-introduced to neutralize the acidic seawater, after which it is returned to the ocean to subsequently draw down an equivalent quantity of atmospheric CO₂.

Captura is currently undergoing a rigorous piloting program to prove out the technology, which consists of three separate systems. The first one, an end-to-end demonstration capable of removing 1 ton of CO₂/year, is fully operational off the coast of Newport Beach, CA at Caltech's research hub, Kerckhoff Marine Laboratory. The next pilot, a 100-ton CO₂/year system, has been successfully operating end-to-end in Captura's labs and will be installed at AltaSea at the Port of Los Angeles to begin ocean field trials in summer of 2023. Lastly, a ~1,000-ton CO₂/year pilot is planned for 2024.

Captura's technology has been third-party validated by several prominent expert entities in the climate space, including XPRIZE, U.S. Department of Energy's APRA-E, and Frontier Climate. In January 2023, Captura announced its Series A financing, led by Equinor Ventures.





CARBONCAPT CHEMICAL ABSORPTION TECHNOLOGY

CARBONCAPT TECHNOLOGIES CO. LTD.

SUMMARY

The existing technologies of Carbon Capture are characterized by high power and thermal energy consumption, but the selective chemical absorption of gaseous CO₂ prevail over the other technologies due to its well proven efficiency in a number of long-term operation at the US and Canada power plants and today all the CCUS community, focused on chemical absorption processes have a challenge to make this technology less expensive, and more accessible to the CO₂ intensive sectors of the global economy.

The expected higher demand for cement and concrete after Covid19 Pandemic will evidently lead to a sharp growth of CO₂ emissions from the cement industry in the upcoming years. Today the urgent need for sufficient reduction of CO₂ emissions all around the world makes this technology vital, if we want to provide green planet Earth for the next generations.

Here we present benefits and a brief description of CARBONCAPT process, the Post combustion Carbon dioxide Capture technology.

BENEFITS

- Process is well-proven in durable operation in multiple plants
- Scalable and extremely cost effective at big capture projects
- Easy and predictable maintenance
- Low CAPEX and OPEX
- Provides for a very little impact on the environment

DESCRIPTION

CARBONCAPT process of CO₂ capture is one of the Post Combustion CCUS technologies.

After dust precipitation in ESP or Bag Filter the flue gases come to CARBONCAPT plant for further treatment.

CARBONCAPT process involves chemical absorption of gaseous CO₂ by highly selective amine-based solvent and executed in three principal stages:

1. First stage – COOLING of the flue gases by water. After leaving the ESP flue gases are drawn up through the COOLING COLUMN (CC) for cooling it from 350-370°C down to 65-70°C by water injection. The diameter and height of the CC as well as the amount of nozzles depends upon the volume and temperature of the flue gases, drawn through the CC.
2. Second stage - ABSORBING of CO₂ by highly selective absorbing solvent. The cooled down flue gases are drawn up through ABSORBER COLUMN (AC). In the AC the flue gases react with FLEXOL-CacboStrip absorbing solvent, thus the chemical absorption of CO₂ is taking place and the CO₂-rich solvent is obtained. The diameter and height of AC and the amount of trays depends mostly upon the reactivity of the absorbing solvent, partial pressure of CO₂ to be absorbed, and the solvent circulation factor. There is a thumb rule:

the lower the temperature of CO₂ and the higher the pressure in the AC, the more effective process of CO₂ stripping is taking place, but in certain cases this rule is not the case at all: the basic engineering should be developed and individual project calculation to be done for every CO₂ capture unit.

3. Third stage – DESORBING of CO₂ from the CO₂-rich absorbing solvent. The extraction of carbon dioxide from the CO₂-rich FLEXOL-CarboStrip solvent occurs by increasing the solvent temperature. As a result the 95% gaseous CO₂ returns to gaseous state and is drawn to a liquefaction station. The FLEXOL-CarboStrip solvent is cooled, regenerated and pumped back to the top of the ABSORBING COLUMN for further circulation.

Today we offer two versions of CarbonCapt technology:

CarbonCapt HP (High Pressure) process with FLEXOL-CarboStrip A4 (Advanced Amine Activated Absorbent) as a solvent, as well as CarbonCapt LP (Low Pressure) process, where FLEXOL-CarboStrip A5 (Advanced Amino-Acid Activated Absorbent) is used. Both versions are cost and energy effective and provide for low CAPEX and OPEX.



CARBONCAPT MOBILE ELECTRODIALYSIS MODULE (EDM) CARBONCAPT TECHNOLOGIES CO. LTD.

SUMMARY

The existing technologies of Post Combustion chemical Carbon Capture widely use the different types of amine-based solvents. These are various formulations, based on different types of amines, i.e. Monoethanolamine (MEA), Diethanolamine (DEA), Methyldiethanolamine (MDEA) as a basic component and Piperazine (PP), used as reaction activator. All these amine-based solvents are doomed to degrade, be lost and contaminated during the circulation and the most important problem here is Heat Stable Salts (HSS) formation. HSS usually exist as amine salts of ionic nature, such as acetate, chloride, formate,

oxalate, thiosulphate, thiocyanate and similar. All of them are thermally stable and not dissociated during the regeneration process. The HSS presence in the solvent results in the following:

- Excessive consumption of amine and loss of its activity towards CO₂
- Increased corrosion of equipment steel surfaces - HSS act as corrosion accelerators
- Fouling, due to salts deposition

BENEFITS

- High efficiency of HSS, SO₂ and carboxylic acids removal,
- Modular design guarantees easy scaling up,
- Minimal environment friendly wastes,
- Reasonable cost of «HSS Withdrawal as a Service»,
- Duration of amine solvent lifetime is prolonged.

DESCRIPTION

In the EDM the anions and cations are separated from the amine solution and concentrated in an aqueous “brine” stream for disposal. Anion and cation selective membranes, divided by spacers, are installed between anode and cathode end plates and operated in a “sheet flow” order.

The spacers designation is to ease the flow distribution between the membranes and to direct amine and brine to the relevant channels. The membranes are sequenced in such a way, that the amine solution enters the channel between an anion and cation permeable membrane, the anions move towards the anode through the anion permeable membrane, and the cations move towards the cathode through the cation permeable membrane.

On the opposite side of the selective membranes the ions migrating from brine to the respective electrodes are precluded by alternating sequence of the membranes: the anion, passing through the anion selective membrane into brine is also prevented from a solvent channel, the next installed is a cation selective membrane, which will never allow the intrusion of the anion.

Our Mobile ElectroDialysis Module is installed in a 40” container and can be easily transported for “Heat Stable Salts withdrawal as a Service” function. For this purpose we use the following algorithm: our specialists will send you the questionnaire to be filled out with the detailed description of the problem, process flowsheet, main process parameters and type of the solvent, used at the amine CO₂ capture unit.

We will also request a sample of regenerated solvent in order to analyze the approximate improvement of operation. After the basic calculations are performed and scope of works is defined we submit a price proposal to the Customer. After the offer is accepted we come to the site and connect our Mobile EDM module to the existing amine carbon capture plant as follows:

1. The EDM module to be installed in the bypass line of the regenerated solvent, pumped to the top of Absorber column,
2. Solvent temperature at the EDM module inlet should not exceed 80°C
3. Pressure is 2-5 kg/cm²
4. Power supply and water source to be provided
5. Needed plot of land is 60 m²
i.e. for 2 pcs 40” containers allocation.



CYCLONECC CARBON CLEAN

SUMMARY

Carbon Clean is a global leader in carbon capture solutions for essential hard-to-abate industries. The company's technology, significantly reduces the costs of carbon capture when compared to existing solutions.

Carbon Clean is an innovation leader in the carbon capture sector, with over 80 active patent assets across 15 patent families covering over 30 countries. The company's standardized, fully modular carbon capture technology, CycloneCC will accelerate the global adoption of carbon capture in key industries that have few other available options to decarbonize.

The size and cost of carbon capture technology have historically been significant barriers to adoption. CycloneCC overcomes these barriers; its overall footprint is up to 50% smaller than a conventional plant and it can capture CO₂ at a cost that is up to 50% less per tonne than conventional carbon capture systems. It achieves

this through a combination of two proven process intensification technologies – Carbon Clean's advanced, proprietary amine-promoted buffer salt solvent (APBS-CDRMax[®]) and rotating packed beds (RPBs).

CycloneCC will be pre-fabricated in fully engineered modules and available in standard capacities. It has already been fully tested at 1 tpd at Altrad Babcock's Emissions Reduction Test Facility in Scotland and a number of 10 tpd demonstration units will be commissioned shortly with select industrial partners in the Middle East and North America. Commercialization of CycloneCC at 100 tpd is also underway in North America and Europe.

As a compact and modular solution, CycloneCC is particularly suited for use with small to mid-size emission point sources and can be installed at multiple locations across a site.

BENEFITS

CycloneCC is a modular, pre-fabricated and skid-mounted carbon capture solution that will radically impact the economics of carbon capture and industrial decarbonization.

CycloneCC's benefits include:

- **Compact and cost-effective:** Process intensification delivers a reduction in the size of the mass transfer equipment by 10 times and up to a 50% reduction in the overall unit footprint, compared to conventional carbon capture units. The overall cost of carbon capture is reduced by up to 50%, with no loss in performance.
- **Easily scaled:** CycloneCC is delivered in modular units that can be added over time to increase carbon capture capacity in line with a company's decarbonization strategy.
- **Standardized designs:** Off-the-shelf, ready-made engineering designs for standard capacities and specifications deliver cost and delivery efficiencies.
- **Minimal disruption:** By using modular designs and shop-fabricated skids, site infrastructure requirements are reduced, resulting in easier integration with existing industrial operations for minimal disruption and maximum cost-effectiveness, and simpler plant maintenance.
- **Proven technology:** Carbon Clean has over a decade of experience in designing, building, and operating industrial carbon capture systems and has technology references across 49 sites around the world. Its engineering excellence and proven results are at the heart of CycloneCC.

DESCRIPTION

Carbon Clean has amassed a deep understanding of industrial carbon capture technologies since its inception in 2009, working with commercial and academic partners to test and validate its solutions. Its proven technologies are delivering for industrial partners around the world and it has technology references across 49 sites.

Carbon Clean delivered the world's first subsidy-free, fully commercial, industrial-scale carbon capture and utilization plant at Tuticorin Alkali Chemicals and Fertilizers Limited in India in October 2016. The plant is installed on a coal-fired boiler, and is designed to capture 60,000 tonnes of CO₂ per year, which is then converted into soda ash (sodium carbonate) – an ingredient used in household products, glass manufacturing, and paper production.

In 2023, Carbon Clean announced its 50th commercial project – to deliver carbon capture equipment capable of capturing 70,000 tonnes of biogenic CO₂ per year for Ørsted's FlagshipONE facility in Sweden, Europe's largest green methanol project. FlagshipONE will supply 50,000 tonnes of eMethanol per year to the shipping industry, which today accounts for around 3% of global carbon emissions.

Carbon Clean is fully focused on making carbon capture more accessible to hard-to-abate industries. Its next generation of standardized, fully modular carbon capture technology, CycloneCC will be crucial to accelerating the global deployment of CCUS.

CycloneCC will be pre-fabricated, enabling an on-site installation period of eight weeks and so reducing costly operational disruptions. Additionally, as a fully modular solution, units can be added in line with a company's decarbonization ambitions and investment capacity, either solo or alongside other decarbonization solutions.

Carbon Clean is also working towards a Carbon Capture as a Service (CCaaS) offering, where customers pay a cost per tonne of carbon. This will further de-risk the investment for companies and ensure performance is optimized over the lifetime of the technology, by drawing on Carbon Clean's operational expertise.

CYCLONECC

Carbon Clean has developed a fully modular technology, CycloneCC, that is vital for scaling industrial carbon capture deployment to achieve global net zero targets.

CycloneCC addresses two major concerns from industries considering carbon capture – cost and space. As a modular, pre-fabricated and skid-mounted carbon capture solution, CycloneCC reduces the overall cost of carbon capture by up to 50% and has a physical footprint that is up to 50% smaller than conventional carbon capture units.

CycloneCC intensifies the traditional solvent capture process through the combination of two process intensification technologies:

- Rotating packed beds (RPBs) process equipment technology
- Carbon Clean's proprietary amine-promoted buffer salt solvent technology (APBS-CDRMax[®])

The APBS-CDRMax[®] solvent is extremely effective in capturing CO₂, and the RPBs provide a highly efficient environment for the absorption of CO₂ and solvent regeneration.

RPBs have been used in commercial applications since the 1960s, however, their use in the post-combustion CO₂ capture process is a new application.

The RPB contains a disk of packing material which rotates about its axis. The centrifugal force generated through the rotational motion of the packed bed in an RPB is significantly greater than the gravitational force seen in conventional packed columns, making RPBs much more effective in mass transfer operations.

The liquid films and droplets created in the packing material are remarkably thinner, which increases the surface area to volume ratio of the liquid. This results in faster and higher mass transfer efficiency between the gas and liquid phases.

The mass transfer improvement allows the RPB to be up to 10 times smaller than traditional columns to accomplish the same results. The combination of RPBs and APBS-CDRMax[®] provides:

- Smaller equipment sizes at equivalent performance – using RPBs in the absorber/stripper results in more than one order of magnitude reduction in equipment size
- Better mass and heat transfer between the liquid and gas phases through thinner liquid films produced by a centrifugal force
- More intense turbulent flow relative to conventional columns

The APBS-CDRMax[®] solvent in the stripper RPB also reduces heat requirements and improves efficiency of heat transfer, collectively reducing the cost to regenerate solvents. Additionally, there are lower degradation and corrosion rates, improving solvent make-up and waste disposal, and a lower pump and cooling water duty.

Further optimizations will be achieved through the use of a digital twin solution, enabling CycloneCC units to be operated remotely to deliver improved plant and energy efficiency, as well as potentially reducing project execution time by 20-40%.

Carbon Clean's CycloneCC technology development process includes rigorous assessment of the technology with academic partners, as well as scaling and adapting the technology to industrial processes with commercial partners.

CycloneCC has been successfully pilot tested at 1 tpd at Altrad Babcock's Emissions Reduction Test Facility in Scotland, and 10 tpd demonstration units will be operational with select industrial partners in the Middle East and North America in the coming months. Commercialization of CycloneCC at 100 tpd is also underway in North America and Europe.

The radically smaller size and cost of CycloneCC offers the potential for industries to achieve far greater emission reductions. Deployment of this technology can also grow in line with a company's decarbonization strategy. Lower overall costs make it possible to incorporate CCUS into existing and future operations, enabling businesses to scale over time to meet their targets and allowing them to participate in the global reduction of carbon emissions sooner.



CycloneCC 10 TPD RPB

APBS-CDRMAX[®] SOLVENT

Carbon Clean's APBS-CDRMax[®] solvent has been formulated to optimize carbon capture performance. Its innovative, patented formulation of amines and salts – amine-promoted buffer salts – offers both the high kinetic reactivity of an amine and the low regeneration energy of a buffer salt. The result is a unique, fast-acting, high-capacity carbon capture solvent that delivers higher performance in any existing solvent-based carbon capture system.

The solvent chemistry allows for rapid removal of carbon dioxide from flue gases with CO₂ concentrations ranging between 2.5-25 vol.% and produces CO₂ with a purity of ≥99.5 vol% on a dry basis, reducing regeneration energy requirements as well as greater stability and lower corrosivity. Comprehensive testing has validated the benefits that APBS-CDRMax[®] delivers including:

- 20x less corrosion and 10x less degradation
- 10-25% lower energy demand for the capture and regeneration process
- 5x longer solvent life and 86% less solvent make-up
- A higher performance efficiency with less foaming, leading to 50% reduction in ongoing chemical requirement and waste disposal costs, reducing amine carryover and the need for anti-foaming additives
- A reduction in solvent emissions to parts per billions (ppb) levels, which meets environmental regulatory requirements and facilitates approvals



CycloneCC 100 TPD visualisation showing its relative size compared to a conventional carbon capture plant



DIRECT AIR CAPTURE CARBON ENGINEERING LTD.

SUMMARY

Direct Air Capture (DAC) is a technology that captures carbon dioxide (CO₂) directly from the atmosphere with an engineered system. This is similar to how trees absorb CO₂ for photosynthesis, except DAC does it much faster, with a much smaller land footprint, and delivers the CO₂ in a concentrated, compressed form. The captured atmospheric CO₂ can then be permanently and safely stored in geologic reservoirs to deliver negative emissions,

or used to produce low carbon intensity products, such as diesel and aviation fuel that work in existing aircraft and infrastructure.

For more than a decade, Carbon Engineering (CE) has pioneered a liquid sorbent-based DAC system, optimized for scale. Today, CE is working with partners to deploy large-scale commercial facilities globally.

BENEFITS

Key features of CE's DAC technology:

- Scalable – Industrial facilities that use CE's DAC technology can be built in one or more trains, each capable of capturing a megatonne of CO₂ annually using known equipment with industrial precedent.
- Standardized design - Alongside partners, we bring a standardized 'design one, build many' approach to deployment, working to duplicate near identical plants adjusted for location specific considerations. This helps support the rapid build-out of large-scale facilities.
- Industrial precedent - At CE, we've built our DAC technology around industrial precedent by utilizing known equipment and suppliers, and then innovating, adapting and integrating them to create our DAC system. This means our system can be built at industrial scales largely with existing supply chains.
- Closed chemical cycle - Our DAC technology captures CO₂ from the air in a closed "chemical loop" that re-uses the same capture chemicals with minimal waste.

DESCRIPTION

DAC technology captures CO₂ by pulling in atmospheric air. Then, through a series of chemical reactions, CO₂ is extracted from the air while returning the rest of the air to the environment. DAC is a different, and complementary, technology to point-source carbon capture and storage which removes CO₂ from industrial flue gas instead of the atmosphere. Within hub or cluster CO₂ storage projects, DAC can bring important value by delivering CO₂ capacity with relatively stable purity and supply.

CE's DAC technology approach is focused on achieving large, industrial scale at low-cost. To help achieve this, CE's solution borrows existing and widely used equipment and processes from other industries, innovating and integrating them to deliver a DAC system based on largely known supply chains, and reliable equipment costs.

Our process begins with an air contactor that is adapted from industrial cooling towers to bring in high volumes of air, which passes across thin plastic surfaces that have potassium hydroxide solution flowing over them.

This commodity chemical binds with the carbon dioxide molecules, removing them from the air and trapping them in the solution in the form of a potassium carbonate salt. The carbonate is then precipitated out of solution in the form of calcium carbonate pellets in a pellet reactor.

In the last major step of the process, the carbon dioxide-carrying pellets are moved from the pellet reactor to a calciner where they are heated to high temperatures causing them to break down and release the CO₂ as a concentrated gas. To close the second loop in CE's process, the calcium oxide left from the calcination process is mixed with water in the slaker to rehydrate it, and then it is fed back into the pellet reactor, beginning the cycle again.

To help minimize waste and consumables across CE's process, the DAC technology uses chemical reactions and this closed loop system to absorb CO₂ from the air (see below).

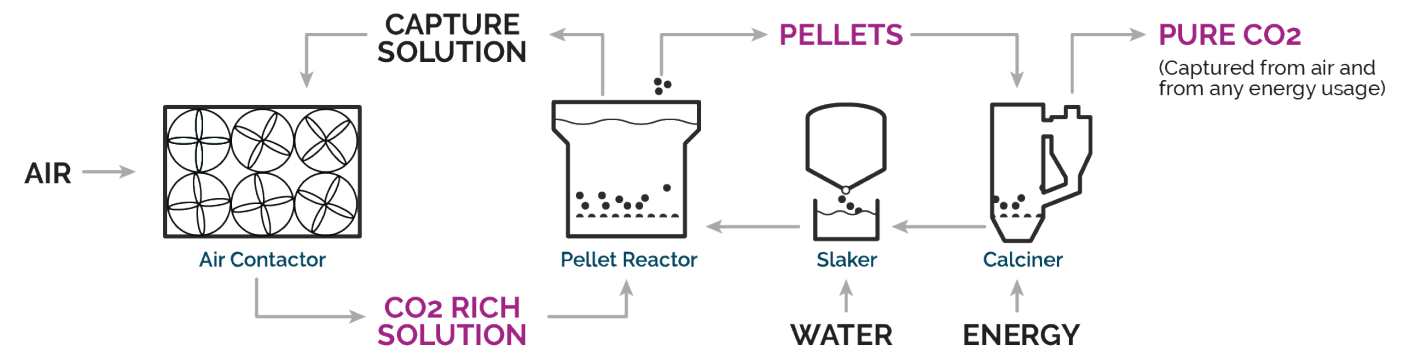

There are a number of applications for atmospheric CO₂ captured through DAC, but CE is focused on delivering two types of industrial solutions:

1. When paired with secure geologic storage, DAC can deliver the permanent and verifiable removal of CO₂ from the atmosphere. This provides a mechanism to help difficult-to-decarbonize sectors, like aviation, address their emissions faster and at a lower cost than many existing mitigation solutions. In the future, in a post net-zero world, these same facilities could be used to address legacy emissions, creating an opportunity for climate restoration.
2. AIR TO FUELS™ solutions can enable captured atmospheric CO₂ to be combined with hydrogen to produce low carbon intensity fuel that is drop-in compatible with existing vehicles and infrastructure.

DEPLOYMENT APPROACH

To enable rapid and widespread deployment of DAC solutions, CE licenses its technology to development partners around the globe so multiple plants can be built in parallel. Alongside regional partners, CE and our global deployment partner 1PointFive – a subsidiary of Occidental's Low Carbon Ventures - bring a standardized 'design one, build many' approach to deployment.

This approach combines the partners' DAC technology, large-scale carbon dioxide management, project experience and extensive storage infrastructure. CE will provide the DAC technology and market support, while 1PointFive builds and deploys the DAC plants, leveraging Occidental's strong project engineering and delivery expertise. This helps support the rapid build-out of large-scale facilities, as we work to duplicate near identical plants adjusted for location specific considerations.

CARBON ENGINEERING'S INNOVATION CENTRE

Built in 2021, CE's Innovation Centre in Squamish, B.C. provides an environment where our engineers and technicians conduct ongoing technology development, testing, and analysis. This center enables CE to continue optimizing our DAC solution to drive down the cost of capture per tonne.

The facility contains all the major components of large-scale, commercial DAC facilities so engineers can test and validate technology enhancements in an integrated system. It includes an air contactor, pellet reactor, calciner, and slaker, alongside an extensive laboratory facility. The next generation technologies developed here in Squamish will then be introduced to commercial facilities worldwide to help drive down emissions and achieve net zero targets.



Carbon Engineering's Innovation Centre and Research & Development Headquarters located in Squamish, Canada.

COMMERCIAL FACILITIES UNDERWAY

The first commercial facility to use CE's DAC technology – being developed by 1PointFive – is under construction in the United States. This first-of-its-kind facility is expected to be capable of extracting 500,000 tonnes of atmospheric CO₂ annually once complete.

Last year, CE announced front-end planning and engineering had begun for DAC facilities at a second site in the U.S., in Kleberg County, Texas. Using the design one, build many approach, the site is expected to provide

access for the potential construction of multiple DAC facilities that would be capable of collectively removing up to 30 million tonnes of carbon dioxide from the atmosphere annually for dedicated sequestration.

This work provides a blueprint for global projects, supporting the design of additional facilities already progressing in multiple markets around the world. Please contact CE if you are interested in licensing our technology to build new, clean-infrastructure projects in your jurisdiction.



Artist rendering of the design of the first large-scale plant to use CE's technology.



NEXT GENERATION CARBON CAPTURE TECHNOLOGY C-CAPTURE

SUMMARY

C-Capture's proprietary next generation carbon capture technology is a true innovation in the sector, and a potential gamechanger for industries looking to decarbonize their processes.

Our patented solvent-based technology selectively removes carbon dioxide (CO₂) from a mixed gas stream. Our mission is to deploy it on industrial emissions using a post-combustion capture approach.

Based on fundamentally different chemistry to other commercially available solutions, C-Capture's carbon capture technology is amine free and environmentally benign. It also uses less energy and is lower cost.

Well suited to the large-scale capture of carbon dioxide and extremely robust, C-Capture's carbon capture technology can be deployed on most processes requiring CO₂ separation from other gases. It is robust enough to withstand even the very challenging flue gases emitted by difficult-to-decarbonize industries including cement, steel, glass, energy from waste, hydrogen production facilities, and power stations.

The advantages of our solution creates the potential for our solvent to break through the barriers that are currently preventing the widespread adoption of carbon capture and storage (CCS) technology to mitigate the impacts of climate change.

BENEFITS

Our proprietary technology uses less energy and is lower cost than other commercially available technologies. It is environmentally benign and extremely robust.

- A novel approach that is amine free, our solvent is inherently biodegradable, non-hazardous, and environmentally benign.
- Our process releases CO₂ more readily than amine-based systems, resulting in a significantly lower parasitic energy demand.

- Significantly reduced process energy requirements (~1.8 GJ/tonne CO₂) due to low steam requirements and reduced costs of compression due to higher CO₂ release pressure.
- Suitable for use in difficult-to-decarbonize industries with a proven high tolerance to flue gas impurities, including O₂, particulates, and acid gases such as NO_x and SO_x.
- High tolerance to impurities reduces the need for feed-gas pre-cleaning.
- Significantly less corrosive than amine-based equivalents, reducing operations and maintenance costs.
- Reduced solvent management costs due to high thermal, chemical, and oxidative stability, and low volatility, which minimizes solvent losses per tonne of CO₂ captured.

DESCRIPTION

NEXT-GENERATION INNOVATION

An innovative UK cleantech company, we've been at the forefront of developing carbon capture technology for over a decade. Our foundations are rooted in innovation, bright ideas, ingenuity, and dedicated people.

We were founded in 2009 as a spin-out company from the University of Leeds when our Founder, Professor Chris Rayner, and his research team were working with CO₂ to find new solutions to the carbon capture problem, building on his 20 years' experience in the field. Their progressive work attracted investment and C-Capture was born.

Our proprietary, next generation technology is based on fundamentally different chemistry that is amine free. C-Capture's patented solvent-based technology captures carbon dioxide (CO₂) from industrial emissions to help combat climate change. It has distinct chemical properties which mean it uses significantly less energy, has lower costs and environmental risks, and has a wider range of industrial applications than traditional carbon capture technologies.

The low cost of capture using C-Capture's technology is derived from the reduced energy demand of our process. C-Capture's solvent components are all highly thermally stable, meaning that higher desorber temperatures can be achieved, creating far greater CO₂ pressures on its release, and reducing the compression energy to prepare CO₂ product for transport and storage.

The robust nature of C-Capture's solvent makes it highly resistant to oxidation and aging, making it suitable for industrial applications that traditional amine-based solvents cannot address (without significant additional capital investment, complexity, and risk), such as steel, cement, waste-to-energy, and refinery catalytic cracker off-gases. This resistance also leads to longer solvent life, further reducing costs.

The advantages of C-Capture's patented technology mean it has the potential to break through the barriers that are currently preventing the widespread adoption of carbon capture technology which in turn make a globally significant contribution to mitigate the impacts of climate change.

Process Enhancements of C-Capture's Technology

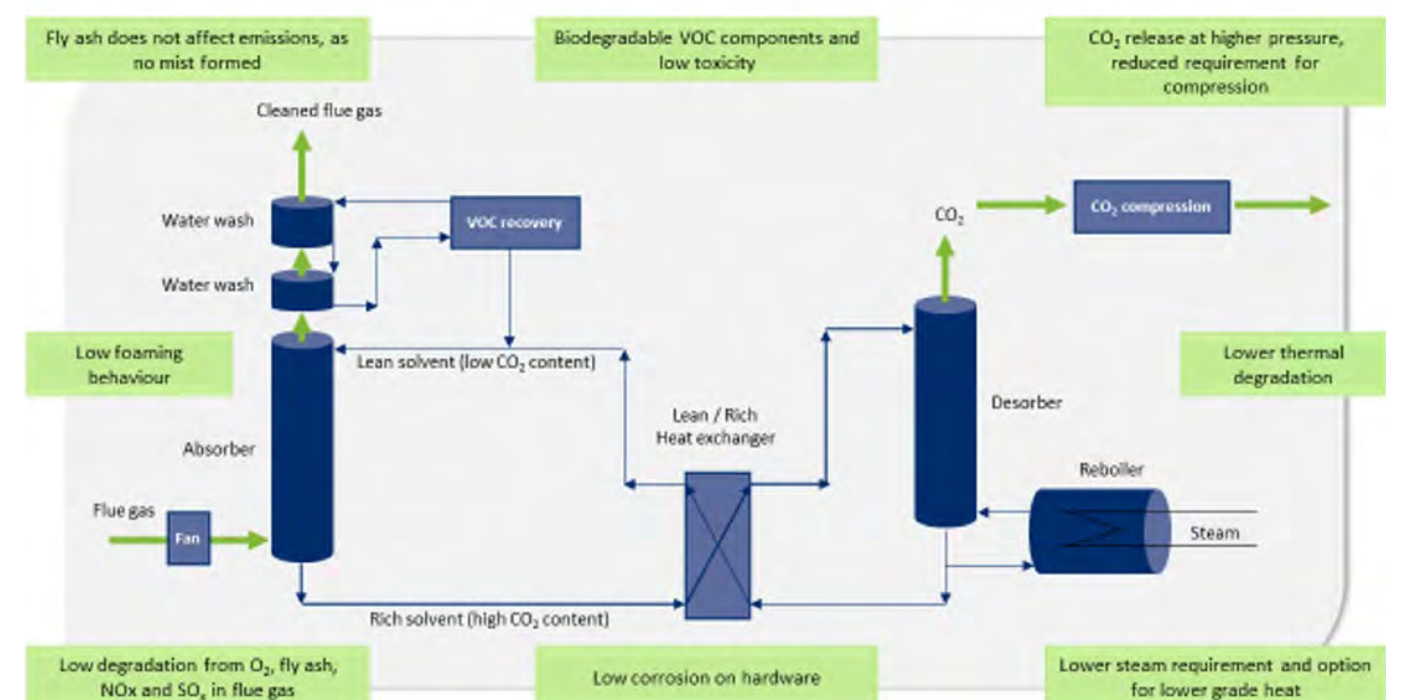

INTERNATIONAL AWARD-WINNING CARBON CAPTURE TECHNOLOGY

C-Capture's next generation carbon capture technology was awarded the trophy in the 'Energy' category of the 2022 IChemE Global Awards.

The international honours are widely considered as the world's most prestigious chemical engineering awards and a global celebration of excellence in the field. The Energy award recognizes excellence in efficient energy use or the development of energy production methods that reduce energy intensity. Our technology was also a finalist in the Sustainability category which recognizes excellence in sourcing and consuming materials, reducing waste, and/or optimising the product life cycles.



BECCS – A WORLD FIRST

C-Capture's technology was deployed to pilot the first bioenergy carbon capture storage (BECCS) project of its kind in Europe, at Drax Power Station, in North Yorkshire, UK.

The plant successfully proved that our proprietary solvent can isolate CO₂ from the flue gases that are released when biomass is used to generate electricity. A major milestone in carbon capture, this pilot was the first time in the world that CO₂ had been captured from the combustion of a 100% biomass feedstock, and a major milestone on the road to achieving negative emissions through BECCS, which is an important part of the raft of solutions required to combat climate change.

DEMONSTRATING OUR TECHNOLOGY

C-Capture's technology is already at Technology Readiness Level (TRL) of 7 and expected to reach 8 by the end of 2023.

Our work continues at the UK's largest biomass power station to continue our commercialization journey. C-Capture's fully integrated pilot plant at Drax Power Station was successfully commissioned at the end of 2022 and builds on the experience gained from our previous prototyping and pilots.

The plant incorporates every unit operation and control mechanism that will be present in a full commercial unit. It has been designed to capture between 1 and 5 tonnes of CO₂ a day.

Currently operating on synthetic flue gas (air/CO₂) each element of the process is being explored and tested in a highly controlled environment. This enables us to map out a clearly defined operating envelope and provide the highest-quality data to customers on how our technology will work within their industry. These data also provide proof of our key capture performance metrics, so we can deliver techno-economic evaluations of our technology for specific industry applications and projects.

When this scope testing is completed, the unit will be moved to Drax's CCUS Innovation Area and operated on biomass-derived flue gas.

By the end 2023 C-Capture will have one year of operation on the pilot unit at Drax along with extensive real-world flue gas trials across key hard-to-abate industries. On the back of this success, we are working to identify the location of our first commercial demonstration unit which will showcase our unique technology at an industrially relevant scale (50-200 tonnes CO₂ capture per day).

PROOF OF THE ROBUSTNESS OF OUR TECHNOLOGY

Alongside the current pilot unit at Drax, C-Capture is building and installing smaller test units – Carbon Capture Solvent Compatibility Units (CCSCUs) – across several hard-to-abate industries. The objective for these is to demonstrate the robustness of our technology within specific applications and provide proof of the exceptionally long lifetime of our solvent.

A fully automated and containerized, small scale carbon capture plant that runs on real flue gas, each CCSCU replicates the temperatures, pressures, and solvent composition changes that would be found in full-scale capture cycle. By replicating the real-world process conditions, but in a low resource intensity manner, we can rapidly gather high quality data to quantify online solvent loss and degradation rates within specific applications.

Since September 2022, the first of our CCSCUs has been carrying out a lifetime test on the biomass-derived flue gas from Drax's boilers. The results to date, combined with data previously gathered from laboratory testing, indicate that C-Capture's innovative solvent technology is highly compatible with biomass flue gas.

ACCELERATING THE DEPLOYMENT OF CARBON CAPTURE TECHNOLOGY

We will demonstrate the compatibility of our technology within several hard-to-abate industries as part of our pioneering XLR8 CCS project.

During 2023, C-Capture will deploy three more CCSCUs to trial and assess the compatibility of our solvent with real-world flue gas across the cement, glass and energy from waste sectors.

This multi-industry, multi-million-pound project, XLR8 CCS – Accelerating the Deployment of a Low-Cost Carbon Capture Solution for Hard-to-Abate Industries, is supported by £1.7m in funding from the UK Government's Net Zero Innovation Portfolio (NZIP). The funding is part of the £20 million Carbon Capture, Usage and Storage (CCUS) Innovation 2.0 programme which is aimed at accelerating the deployment of next-generation CCUS technology in the UK.

C-Capture's XLR8 CCS project will demonstrate that a low-cost carbon capture solution is a reality for difficult-to-decarbonize industries in the race to net zero. A critical step in the fight against climate change to de-risk future CCS projects and investments at commercial scale and deliver the cost reductions required to decarbonize all industry sectors.

The project will prove that C-Capture's next generation carbon capture solvent is compatible with a wide variety of harsh, real-world industrial emissions, which are major contributors to global carbon levels.



CAPSOLEOP® AND CAPSOLGT® CAPSOL TECHNOLOGIES

SUMMARY

Capsol Technologies has developed and offers safe, environmentally friendly, energy-efficient and affordable carbon capture technologies for large scale emitters like Energy-from-Waste (EfW), biomass plants, cement producers, gas power stations, and other CO₂ emitting industrial facilities utilising the safe and proven Hot Potassium Carbonate (HPC) solvent.

HPC as an absorption solvent for CO₂ is well-documented and used in thousands of plants globally in multiple industries. However, until recently, the use of HPC for post-combustion capture of CO₂ from flue gases was discarded as a viable option due to the high energy demand (and

hence cost) required to pressurize the flue gas. To solve this, Capsol Technologies has developed the CapsolEoP® (end-of-pipe) technology – a standalone, retrofit unit, with a patented energy recirculation process, which offers low capture cost and the flexibility to monetize heat and electricity in the capture process.

Building on the CapsolEoP® technology, Capsol Technologies has recently developed an optimized carbon capture process for gas turbines - CapsolGT® - which generate additional electricity while capturing 95%+ of the CO₂ from the exhaust gases of open cycle gas turbines, introducing carbon capture as a revenue source.

BENEFITS

- Cost competitive: The patented energy recirculation enables lowest carbon capture costs and flexibility to monetize heat and/or electricity from the capture unit.
- Safe solvent, free of harmful emissions: The use of Hot Potassium Carbonate (HPC) is non-toxic, non-flammable, non-carcinogenic and environmentally friendly.
- Low solvent degradation minimizes cost of solvent makeup.
- Flexible and scalable: A single CapsolEoP® unit can process flue gas from plants with emissions of up to maximum 2.5 million tonnes of CO₂ per year (with flue gas CO₂ concentration of 20%).

- Two or more units will operate in parallel for facilities with emissions of more than 2.5 Mtpa CO₂
- CapsolGT® is optimized for 4-100 MWe turbines
- Minimal plant impact: The system can be run on electricity only. There is no external steam required. No modification of the host plant is needed
- Experienced team: Technical and commercial experts from the Energy, Chemical and Oil & Gas industry, with 25+ years' experience

DESCRIPTION

CAPSOLEOP® - SAFE, ENERGY EFFICIENT AND COST COMPETITIVE END-OF-PIPE CO₂ CAPTURE

A simplified overview of the CapsolEoP® process is presented in Figure 1. The CO₂ rich flue gas is compressed to around 5-8 bar (to achieve a partial CO₂ pressure of 0.7 bar) before it enters the bottom of the absorber, where the pressurized flue gas reacts with the downwards flowing HPC solvent. The CO₂ lean flue gas leaves the absorber column at the top. The CO₂ rich solvent leaves the absorber at the bottom, is depressurized, and led to the top of the desorber, where the partial CO₂ pressure is low, forcing the solvent to release its high CO₂ content to the steam flow. The pure CO₂ leaves the top of the desorber, from where it can be liquified and further processed. The lean solvent is led back to the top section of the absorber, and the cycle continues.

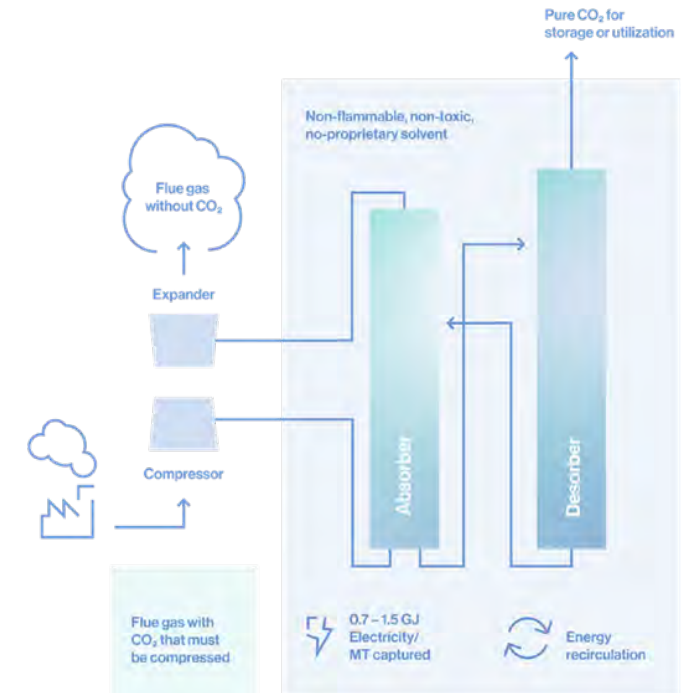

Figure 1

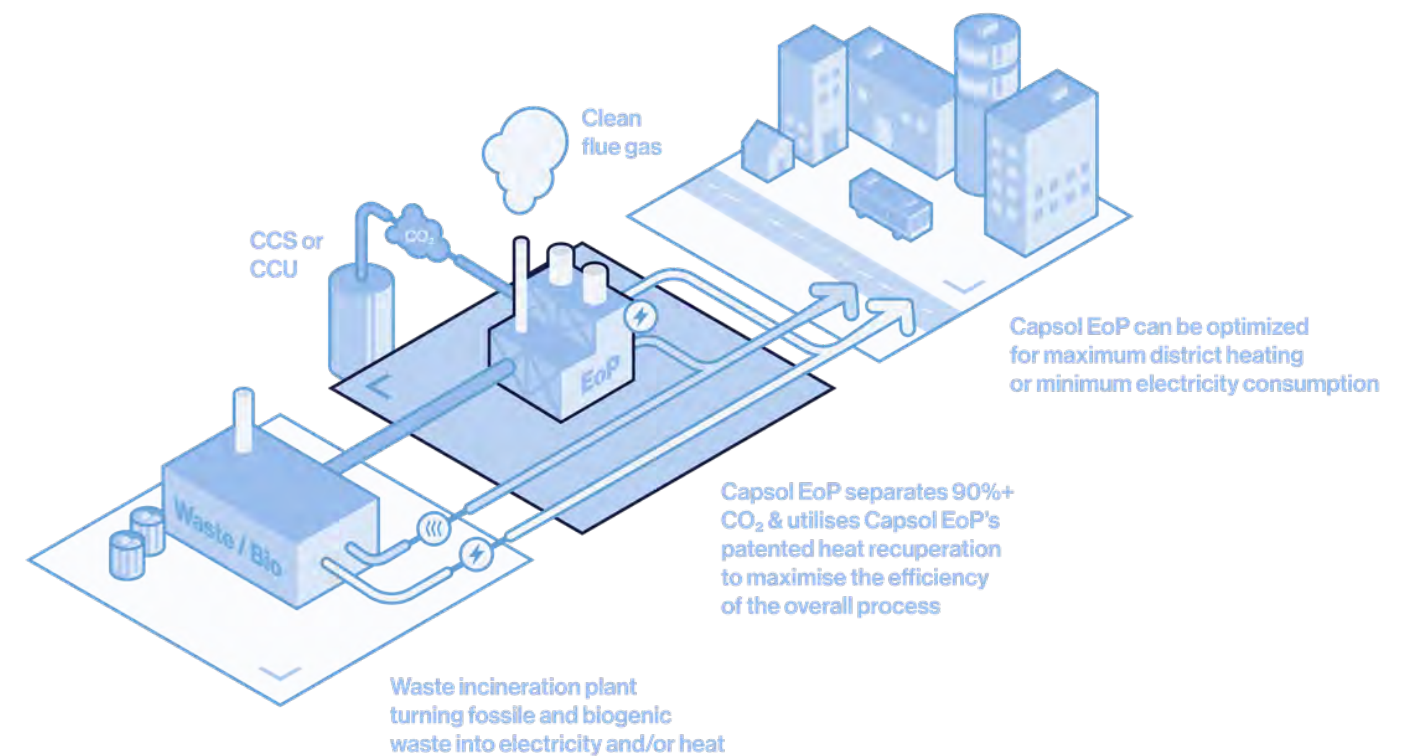

Figure 2

CapsolEoP® can be run on electricity only or use excess steam from the host plant, if available. Thus, a costly investment in external steam production, or reconstruction and balance of the host plant, is not required.

CapsolEoP® offers great flexibility – optimizing either for minimum electricity consumption, or for maximum internal heat generation, for example for district heating.

The CapsolEoP® heat recirculation can efficiently produce 1.3 bar steam from water at 75° to 90 °C by heat pumping. In addition, process waste heat (at temperatures above 75 °C) from the host plant may be used in the CapsolEoP® process to decrease the energy demand of the overall system (when optimized for minimum electricity consumption). Alternatively, the capture plant can be optimized to add valuable energy in the form of heat to a district heating network, with a minimal increase in electricity consumption.

The CapsolEoP® solution can also commercially make use of the energy from the CO₂ compressor intercoolers (in the liquefaction plant) by integration into the energy recirculation. In addition, depending on the temperature, the energy in the flue gas entering the CapsolEoP® unit can also be used in the heat recirculation process. Whether to optimize for lowest electricity consumption or maximum heat into the district heating system is reviewed for each specific plant based on close dialogue with the plant owner.

CAPSOLGT® - INTEGRATED CARBON CAPTURE FOR GAS TURBINES

CapsolGT® - Capsol Technologies' carbon capture solution for open cycle gas turbines, capturing 95%+ of the carbon dioxide while enabling additional electricity generation, is a solution optimized for 4-100 MWe gas turbines that do not require turbine modifications, in addition to introducing carbon capture as a revenue source.

Highly efficient gas turbines provide low CO₂ concentrated, hot flue gas streams with temperatures typically around 500-600 °C. Before entering the core of the capture cycle, the flue gas heat is recovered, utilising the pressurized clean gas absorber stream, to generate an overall surplus of electricity. In comparison with a typical combined cycle gas turbine plant (CCGT) with end-of-pipe carbon capture, CapsolGT® provides a low cost, less complex and high capture rate alternative. The overall cooling demand is also lower, and the plant is able to provide valuable heat 30 – 105 °C, if required.

The solution can be applied to a variety of applications, such as gas engines, diesel generators and other industrial facilities where hot waste heat streams could be utilized.

The steam required for the process is exclusively generated within the capture system, by the means of electricity. CapsolGT® avoids the costly investment into a separate steam boiler and additional end-of-pipe carbon capture system. With less equipment, lower external cooling requirements and water neutrality, CapsolGT® achieves higher overall plant efficiencies. CapsolGT® can operate without additional supply of water, in fact, there is the possibility to accumulate significant amount of water and waste heats, which can be utilized, for example for external steam production or water supply.

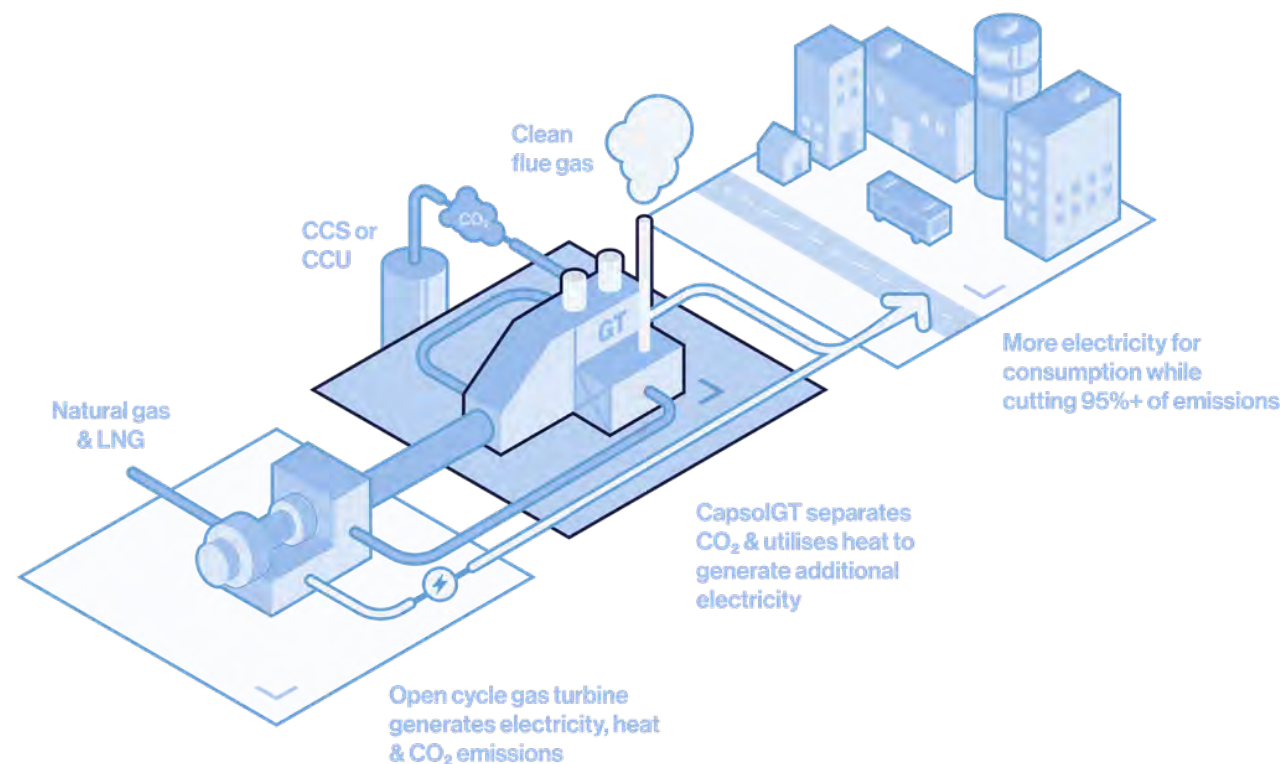

Figure 3

CAPSOLGO® – EFFECTIVE DEMONSTRATION CAMPAIGN TO ACCELERATE YOUR CARBON CAPTURE PROJECT

CapsolGo® is the answer to the many challenges of industrial emitters, who consider investing into a full-scale carbon capture plant. CapsolGo® is a small-scale carbon capture demonstration unit for industrial facilities such as Energy-from-Waste and biomass power plants, as well as cement factories. CapsolGo® consists of two, easily deployable shipping containers, stacked on top of each other to minimize footprint, which are easy to install. The only infrastructure required is electricity, compressed air, demineralized water, and of course, the flue gas. The captured CO₂ can be fed back to the flue gas stack, or it can be liquefied to demonstrate utilization options.

CapsolGo® is provided with an all-inclusive package: transport, installation, deinstallation, operation, and reporting by an independent party. CapsolGo® offers many advantages for industrial emitters, including:

1. The opportunity to experience Capsol Technologies' energy-efficient technology to verify the effectiveness of our carbon capture technology before investing in a full-scale plant
2. Experience the safe and environmentally friendly

carbon capture solvent potassium carbonate (HPC). An increasing number of industrial facilities have heard about potassium carbonate and understand the many advantages of it, like lower capture and material costs, in addition to being widely available and no risk of harmful emissions. CapsolGo® provides a powerful tool to demonstrate safe carbon capture to stakeholders

3. During a CapsolGo® campaign, the plant's specific flue gas and operation is tested to define an optimal solvent blend for the full-scale carbon capture plant.
4. Operation and maintenance teams can get familiar with Capsol's technology and prepare for the full-scale operation. The public, such as residents, can experience the environmentally friendly carbon capture solution live, in person.

With an independent test report, plant owners will be able to accelerate their decision processes towards the full-scale plant and enhance the quality of their soft funding applications.

With a capture capacity of several hundred tonnes of CO₂ per year, CapsolGo® enables maximum insights about the technology, while at the same time making it affordable.



CapsolGo® unit 1 at Filbörnaverket, Helsingborg, Sweden.



CapsolGo® unit 2 at German EfW (Energy-from-Waste) plant.

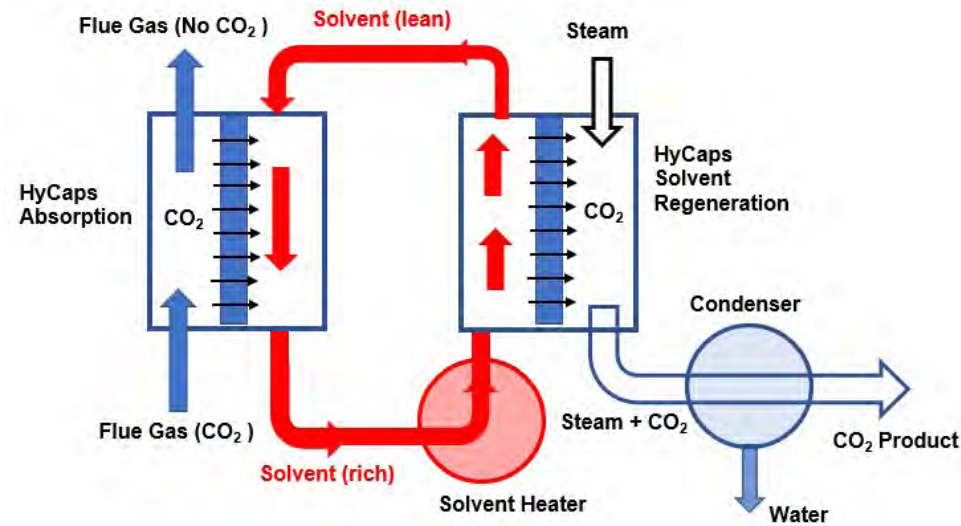

HYCAPS- HYBRID CAPTURE SOLUTION CO2CRC LTD.

SUMMARY

Operating since 2003, CO2CRC is a world leader in carbon capture, utilization and storage (CCUS) research. CO2CRC works with national and international discipline leaders, manages interdisciplinary and inter-institutional research projects, has well-established, decade-long relationships, strong international brand recognition, and an outstanding health and safety record. CO2CRC develops and trials next generation low-emission technologies in commercially relevant, first-of-a-kind demonstrations.

CO2CRC Ltd. in collaboration with its research partners in Australia has developed a hybrid CO₂ capture technology, HyCaps. HyCaps combines solvent absorption and membrane separation in a single process, which exploits the advantages of both technologies to achieve efficient carbon capture. The HyCaps process has proven its ability to be highly efficient at carbon capture with reduced energy requirements. HyCaps is modular, scalable and its footprint is substantially lower than the conventional amine solvent process for CO₂ absorption, making it suitable for retrofitting existing plants thereby promoting faster implementation of carbon capture utilisation and storage (CCUS).

BENEFITS

HyCaps is a hybrid technology that takes advantage of both the highly selective nature of solvent absorption technology and the controlled flow regime of membrane technology. HyCaps provides the following benefits over conventional solvent absorption technology.

- HyCaps modules provide very high surface area to volume ratios. Consequently, the equipment size for carbon capture is significantly reduced compared to conventional solvent absorption columns.
- The separation of the solvent and flue gas streams by the membrane, eliminates solvent foaming, flooding and reduces liquid channeling, the major operating issues in solvent absorption in packed columns. Also, there is no need for solvent redistribution.
- The HyCaps modules can be oriented in any direction without impacting the performance. Lower footprint, flexibility in orientation and its modular design enables HyCaps' capture process to be easily accommodated into limited spaces, making the technology ideally suited for retrofit applications as well as incorporation into new build designs.
- Solvent regeneration does not require reboiling/phase change, significantly reducing the solvent regeneration energy as compared to the conventional absorption technology.
- Ultimately, HyCaps is a very cost competitive technology with potential to reduce CO₂ emissions in hard-to-abate sector, oil & gas, onshore and offshore oil and gas platforms, ship-based processes, biogas upgradation and many more.

DESCRIPTION

HyCaps is a hybrid technology that combines mature solvent technology with membrane technology to overcome inherent limitations while retaining or enhancing their advantages – as shown in Figure 1.

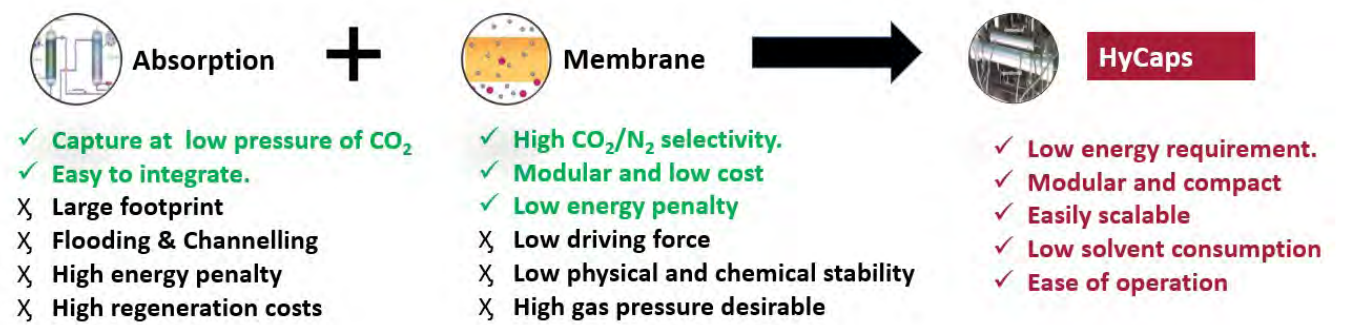

Figure 1- Combining two technologies efficiently in HyCaps.

Figure 2 is a typical flow sheet of the HyCaps process. The flowsheet is similar to that of conventional solvent CO₂ capture systems but with the HyCaps module replacing the conventional packed columns for absorption and solvent regeneration. The process involves the transfer of CO₂ from the gas mix through a hollow-fiber membrane, where it is chemically absorbed into a solvent. In solvent regeneration with HyCaps, the physical separation of the solvent and gas phases by the membrane enables carbon dioxide to

be drawn from the enriched solvent phase into the gas phase. This enables solvent regeneration to be achieved at temperatures lower than conventional packed columns and the solvent regeneration can be achieved without vaporisation of the solvent. By avoiding vaporisation of the solvent, the HyCaps process reduces the energy demand of the solvent regeneration significantly.

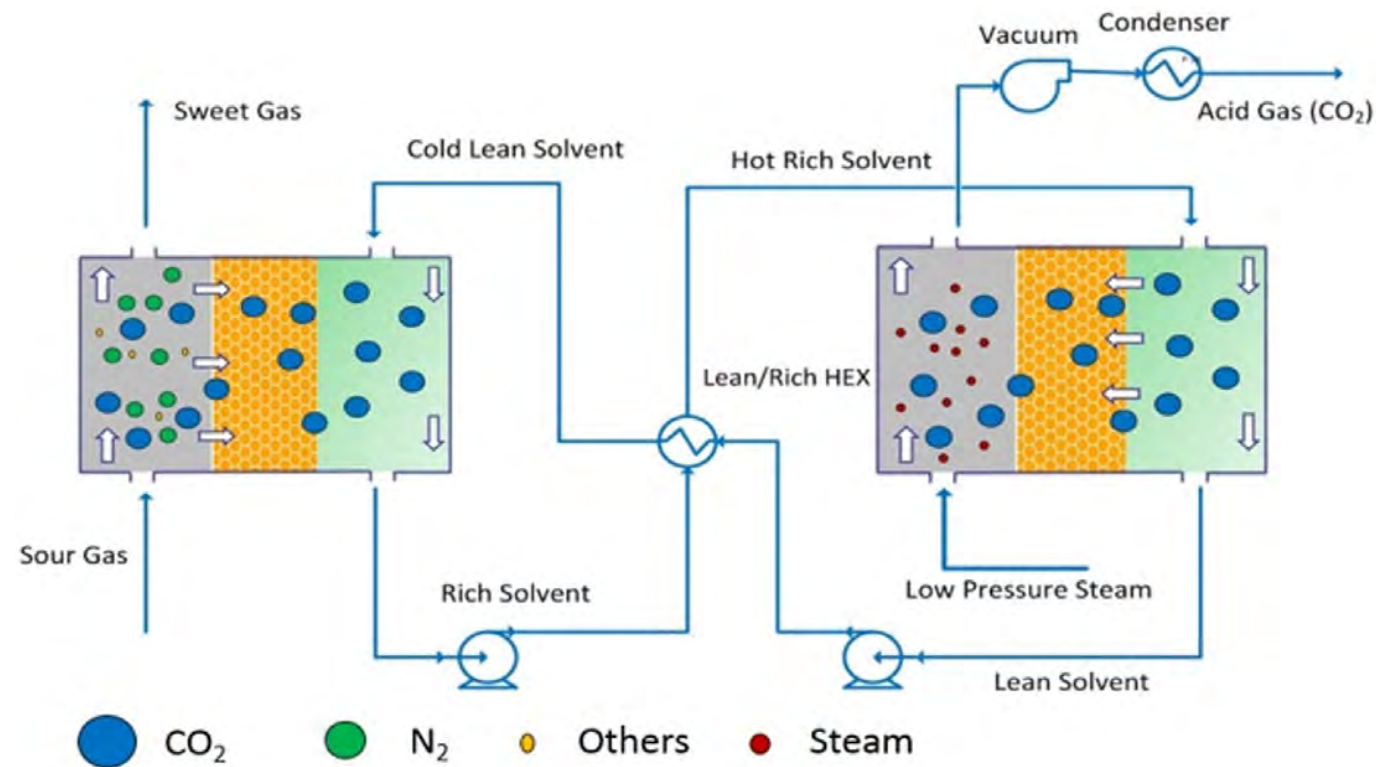

Figure 2 - HyCaps process undertaking carbon capture and solvent regeneration.

TECHNOLOGY DEVELOPMENT

CO₂CRC Ltd and its research partners have successfully demonstrated the potential of HyCaps technology for both post-combustion and pre-combustion carbon capture scenarios. This novel technology represents over a decade of laboratory research and three pilot plant industrial trials: The 30 wt% monoethanolamine (MEA) solvent was chosen for pilot testing because of its well characterized performance and the industry standard for CO₂ solvent absorption. Hence, the performance of the HyCaps pilot plant could be directly correlated with conventional solvent absorption processes, with improvements in carbon capture efficiency and energy penalty directly correlated to the HyCaps technology. In this process, the solvent regeneration operating temperature ranged between 90 to 102 °C, well below the solvent vaporization temperature

of 105 °C. Hence, the pilot plant proved that carbon capture and solvent regeneration could occur without a bulk solvent phase change.

To ensure rapid scale-up of HyCaps technology, the membrane based HyCaps modules chosen were based on commercially available membranes, which were originally developed for other gas separation applications. Therefore, the technology can be rapidly adopted by industry and expanded without the need for membrane material development or the construction of sophisticated membrane fabrication facilities.

It is also important to note that ongoing developments on either the solvent or membrane systems can be transferred seamlessly to the HyCaps module – a further benefit of the system that will ensure its future relevance to the industry.

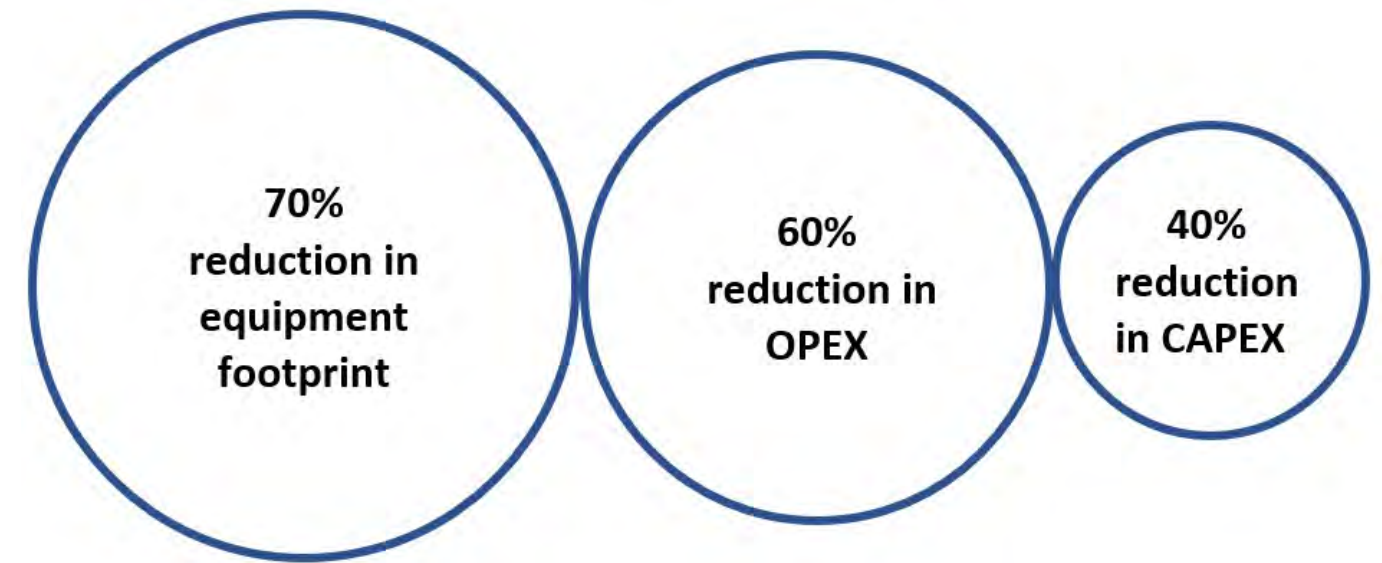

Figure 3- Cost effectiveness of HyCaps compared to conventional solvent process for CO₂ capture from flue gas having 18% CO₂.

COST EFFECTIVE TECHNOLOGY

Initial techno-economic analysis done for the CO₂ capture with 18% CO₂ in the flue gas indicates the cost effectiveness of HyCaps technology. HyCaps modules has 5000-6000 m² surface area per m³ of the volume as compared to 500-800 m²/m³ for the conventional packed columns. As a result, HyCaps modules have a reduced equipment footprint by 70%. Significant reduction in equipment size is also a factor in reduced CAPEX for HyCaps. The avoidance of solvent boiling and lower operating temperature results in a low energy demand for regeneration, and the low quality heat/waste heat from the plant can be utilized within the system, making the whole regeneration a low OPEX process. When compared to conventional solvent process the operating cost of HyCaps is about 60% lower as shown in Figure 3.

The development of the hybrid HyCaps represents a new approach in carbon capture that has clear advantages in terms of energy requirement and footprint, compared to conventional technology. Critically, the technology, proven at three different industrial pilot plants in Australia, has demonstrated the deployment readiness of HyCaps to address carbon emissions from industrial sources including the hard-to-abate sector. HyCaps is a modular, compact, and scalable technology that can be applied to post combustion as well as pre combustion CO₂ capture processes. Due to its compact design, flexible orientation and ease of installation, it is suitable to be retrofitted to any industry with limited space but not limited to hard-to-abate sector, mobile process platforms like FPSO, and ship-based processes.

NEXT STEPS

With three successful pilot demonstrations in different industrial environments, HyCaps has achieved a technology readiness level (TRL) 6. HyCaps is a cost competitive CO₂ capture technology and is ready for scale up and large-scale demonstration. As a next step, CO₂CRC is working on a scaled up design for the equipment and is looking for potential funding and collaboration opportunities to test and showcase HyCaps technology in different industrial applications and environmental conditions.

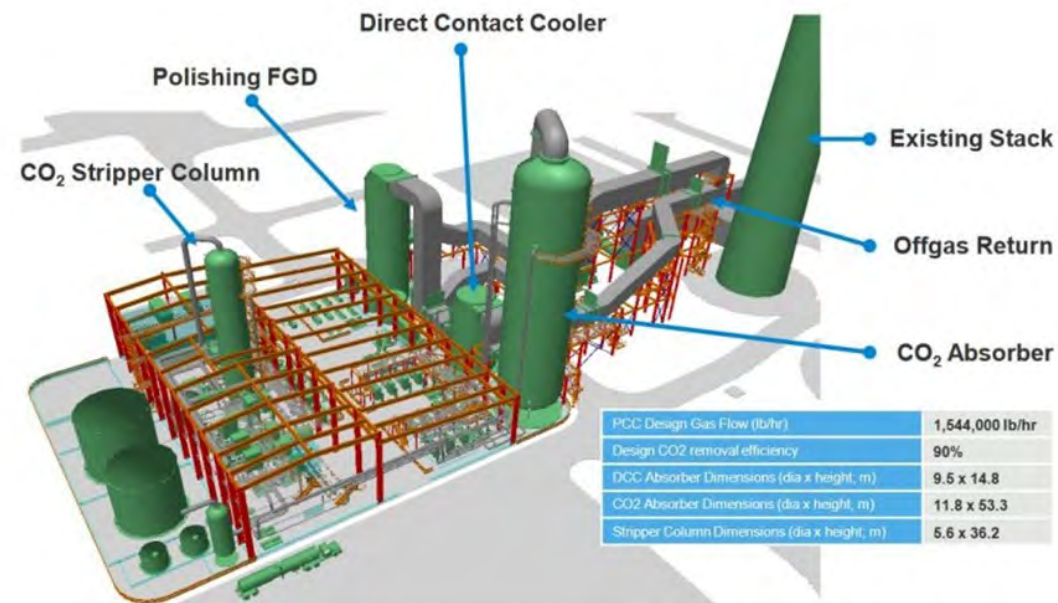

LCDESIGN®, DELTA RECLAIMER®, DELTSOLV® DELTA CLEANTECH

SUMMARY

DELTA CleanTech is globally recognized as a leading provider of technology for Pre- / Post- Combustion Carbon Capture from industrial sources, enabling significant and economical reduction of greenhouse gas emissions since 2004. DELTA's goal is to deliver practical solutions to reduce greenhouse gas emissions and help solve the challenges of energy security.

Through its commercial relationships, DELTA implements the Best Commercial Technologies (BCT) in carbon capture and utilization with leading EPC's and Fabricators around the world.

Delta has developed its own proprietary technologies as follows;

- Low-Cost Design Carbon Capture System, LCDesign®
- Solvent Purification & Recycling System, Delta Reclaimer®

The collective experiences from over 100 Carbon Capture Projects worldwide provides Delta a distinct advantage. Delta has successfully designed carbon capture plants with capacity from 1 to 7,000 metric tonne of CO₂ per day (tpd).



BENEFITS

- **Simplicity:** LCDesign® process configuration is simplified compared to both the traditional amine system and advanced technologies.
- **Scalability:** LCDesign® can be scaled from 1 to 7,000 tpd or more.
- **Affordability:** LCDesign® is truly the most affordable carbon capture system in the market with the lowest CAPEX & OPEX.
- **Integrability:** LCDesign® can be fitted with a new or existing Pre-/Post- Combustion process.
- **Suitability:** LCDesign® can capture CO₂ from any gas stream at wide CO₂ content (from 2.5 to 70 volume %)
- **Performability:** LCDesign® can be designed to capture CO₂ at any recovery ratio (up to 99%) lower energy compared to conventional solvent-based techniques.
- **Solvent Availability:** DeltaSolv® solvents are commercially available with no royalty fees.
- **Emission Reduction:** LCDesign® reduces emissions to atmosphere to the minimum with DeltaWash™ technology.
- **Operation Philosophy:** LCDesign® requires a minimum operation attention and can be designed to be automated (no need for site staff 24/7)
- **Operation flexibility:** LCDesign® can be operated in a wide range of gas and liquid loads (30 to 120% design load)
- **Team Expertise:** Delta Team are professionally trained and skilled carbon capture designers with experience in Construction, Commissioning, Operating and Troubleshooting Plant Operations.
- **Project Execution:** DELTA can work alongside the EPC Firms of your choice.
- **Maturity:** LCDesign® Technology Readiness Level (TRL) is 9 and it is Build Ready!





ELESSENT FLUE GAS PRE-CLEANING FOR CARBON CAPTURE UNITS (CCUS) ELESSENT CLEAN TECHNOLOGIES

SUMMARY

Elesent Clean Technologies (Elesent) provides wet gas cleaning systems for pre-cleaning and cooling hot dirty flue gas streams ahead of carbon capture units (CCUs) for CO₂ reduction. Elesent's BELCO® scrubbing technology is in widespread use on refinery fluid catalytic cracking units (FCCUs), fluid cokers, boilers, and process heaters. Our DynaWave® scrubbing technology is in use on many applications that include refinery sulfur recovery units (SRUs), sulfuric acid plants, metallurgical plants, cement kilns, power plants, incinerators and other applications requiring robust flue gas cleaning. Originally developed and used to minimize flue gas atmospheric emissions, our wet scrubbing technologies can meet the extremely low

flue gas contaminant concentrations specified by CCU suppliers for particulate matter (PM), sulfur oxides (SO_x), nitrogen oxides (NO_x) and aerosols. Flue gas cooling to meet low moisture (H₂O) content and low temperature requirements for some CCU technologies can also be provided. Where additional control of acid mists, aerosols and/or fine particulate is required, for more meeting more stringent cleaning requirements, Elesent can incorporate the use of wet electrostatic precipitators (WESPs) for dirty flue gases or Brink® brownian diffusion fiber bed mist eliminators. Elesent's Brink® mist eliminators are also well suited for controlling amine mist downstream of amine-based CO₂ absorption units.

HIGHLIGHTS

- Proven scrubbing performance for severe service hot dirty flue gas applications
- 500+ scrubbing installations with unique BELCO® and DynaWave® technologies
- Refinery FCCUs, boilers, heaters, fluid cokers and SRUs installations
- Sulfuric acid plants, metallurgical plants, cement kilns, power plants, and incinerator installations
- Capable of meeting extremely low particulate matter, SO_x and NO_x concentrations
- Robust non-plugging scrubbing designs using open towers
- Compact plot space requirements
- Minimal energy and water usage
- Brink® brownian diffusion mist eliminators for clean flue gas applications and amine emissions reduction

DESCRIPTION

BELCO® WET SCRUBBING

BELCO® scrubbing is the leading technology used in oil refineries for cleaning flue gas from FCCUs that are typically operated uninterrupted for 5–7 year periods. Particulate Matter (PM) (including mist and aerosols), SO_x and NO_x are controlled in a single up-flow tower with a staged cleaning approach that supports optimizing system configurations to meet specific application needs, while minimizing flue gas pressure drop and system costs. Common acid gas buffering reagents (NaOH, NaCO₃ and Mg(OH)₂) are typically used for FCCU and other oil refinery applications (fluid cokers, power boilers and fired heaters). The use of other reagents is also supported.

With BELCO® scrubbing, hot-dirty flue gas is quenched/saturated flowing into a horizontal inlet in the lower portion of an up-flow tower. When NO_x control is required, gas that is rich in ozone is injected into oxidized NO_x for easily scrubbed HNO₃. Acid gases and coarser PM are removed with buffered water sprays as gas flows up through the vertical tower. Finer PM is removed with a unique particulate growth and buffered water spray filtration stage. Liquid droplets are removed in a final stage at the top of the tower.

TYPICAL BELCO® WET SCRUBBER

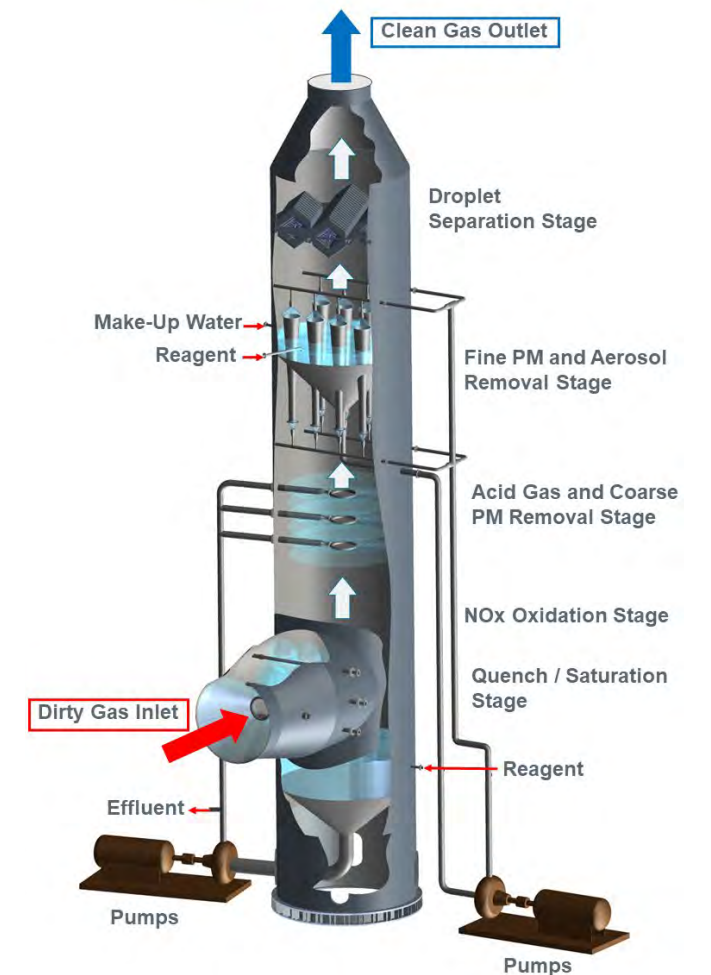

DYNAWAVE® WET SCRUBBING

DynaWave® scrubbing is widely used for gas cleaning on refinery SRUs, sulfuric acid plants, metallurgical plants, cement kilns, power plants, and incinerators. Cleaning is provided using a unique reverse-jet technology within a single vessel. Systems are customized for specific application requirements for removal of PM, acid gases (SO_x, HCl, HBr, H₂S, HCN, Br₂, Cl₂, I₂, F₂), NH₃ and/or NO_x. The technology supports the use of a wide variety of common acid gas buffering reagents, as well as specialized reagents that include caustic, soda ash, lime, limestone, zinc oxide, magnesium hydroxide, ammonia, and hydrogen peroxide. Other reagents can be used in special applications like Cement Kiln Dust (CKD) in cement plants and Black Powder in zinc plants.

Hot dirty gas flows down into the inlet barrel while buffered liquid is sprayed upward into the barrel. Liquid collides with the down-flowing gas to create the “froth zone”, a region of extreme turbulence with a high rate of mass transfer. Clean, water-saturated gas continues through the scrubber vessel to mist removal devices. The liquid reverses direction and returns to the vessel sump for recycling back to the reverse jet nozzle.

BRINK® FIBER BED MIST ELIMINATORS

Used in 5000+ facilities around the world, Brink® mist eliminators provide effective elimination of fine aerosol mists, submicron oil smoke and soluble solids from a wide range of gas streams. Originally developed for use in phosphoric acid plants, custom engineered systems are used for a broad range of industries including everything from sulfuric acid to asphalt manufacturing, plastic extrusion, metalworking and many more. For CCUs, Brink® mist eliminators may be used as part of our BELCO® and DynaWave® wet scrubbing systems, or as a separate system ahead of or after a CCU.

Using Brownian diffusion principles, Brink® mist eliminators consist of thick layers of very fine fibers placed between two concentric cylindrical screens or cages. Fiber beds are placed within a collection vessel to allow for gas to be conveyed through the devices. Mist and aerosols collect on the fiber bed and coalesce to form liquid films that drain down through and out of the filter by gravity. These devices offer exceptional collection efficiency for meeting stringent emission guarantees, and in cases where insoluble particulate content in the gas is low, they can achieve many years of trouble-free operation.

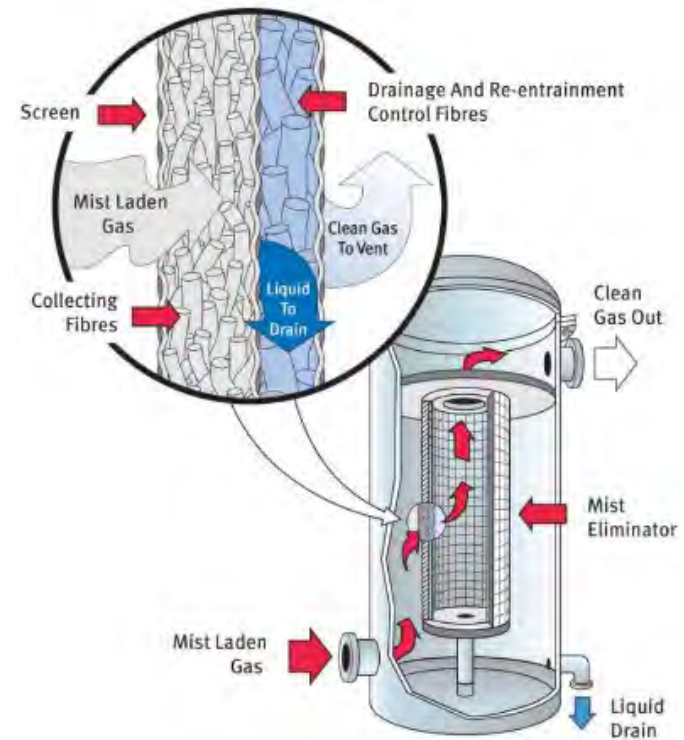
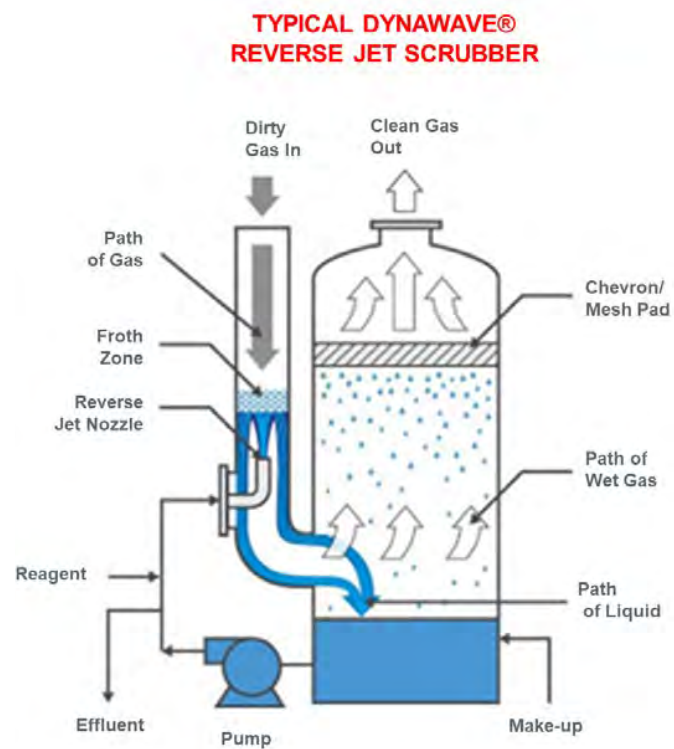



FUEL CELL BASED CARBON CAPTURE SOLUTIONS FUELCELL ENERGY

SUMMARY

FuelCell Energy, Inc is a provider of power generation and hydrogen solutions based on high temperature electrochemical technologies. One of those platforms, the molten carbonate fuel cell, offers a unique approach to capturing carbon dioxide from power generation or thermal sources while simultaneously producing power. The company has been offering power generation platforms based on the carbonate fuel cell technology commercially since 2003, and over 200 MW of systems are in operation around the world. Carbonate fuel cells generate power in electrochemical reactions that are supported by an electrolyte layer in which carbonate ions serve as the ion bridge that completes the electrical circuit. A side effect

of this basic characteristic of the technology is that carbon dioxide introduced at the air electrode is transferred through the electrolyte layer to the fuel electrode, where it is more highly concentrated and easy to remove. This means that a carbonate electrochemical cell can be used as a carbon purification membrane – transferring CO₂ from a dilute oxidant stream to a more concentrated fuel exhaust stream. These cells are not developmental items – they are industrial scale components configured into large cell-stacks in MW-scale fuel cell powerplant systems that are commercially deployed around the world today, and an effort is underway to optimize the cell configuration for carbon capture.

BENEFITS

- Co-production of power during carbon capture, which provides an additional revenue stream to offset the cost of carbon capture.
- Co-production of clean water from the fuel cell reaction, which can be used to offset water requirements of the coal or gas system that CO₂ is being captured from.
- NOX destruction. Reactions occurring on the carbonate electrode surfaces destroy NOX, so processing flue gas in a carbonate fuel cell system will destroy up to 70% of the NOX in the flue gas, reducing or eliminating capital and operating costs for NOX destruction equipment.

- Modular, can be deployed incrementally to manage capital outlay and changes in the cost of power, and to address a wide scale of application sizes.
- Wide range of applications, from industrial thermal sources as well as coal or natural gas power generation systems

DESCRIPTION

A key advantage of fuel cell power generation over combustion heat engine systems is that fuel is converted to power more directly through an electrochemical non-combustion reaction. This direct conversion is more efficient and avoids the production of pollutants such as NOX and particulates associated with combustion based power generation. Fuel cells are electrochemical devices comprised of negative and positive electrodes that can be connected in a variety of series or parallel electrical configurations to get the desired system voltage. The negative electrodes produce electrons, and the positive electrodes consume electrons, producing the electrical current. Chemical reactions at the electrodes drive the electron production and consumption. An electrolyte layer between the electrodes supports ion transfer from positive to negative electrodes to maintain charge balance as electrons are produced and consumed. In fuel cells the

chemicals that drive the power reaction are continuously fed into the cells during power production. Typically, a fuel flows through the negative electrodes (anodes) and air flows through the positive electrodes (cathodes). The fuel is often hydrogen, but in the case of carbonate fuel cells methane (from natural gas or biogas) is used and converted to hydrogen inside the fuel cell.

In carbonate fuel cells the electrochemical reactions are supported by an electrolyte layer in which carbonate ions serve as the ion bridge that completes the electrical circuit. During power generation the carbonate ion transfer results in carbon dioxide being produced in the fuel electrodes and consumed in the air electrodes. This carbon dioxide flux is what is used for carbon capture. The cell and stack structure and electrochemical reactions are illustrated below:

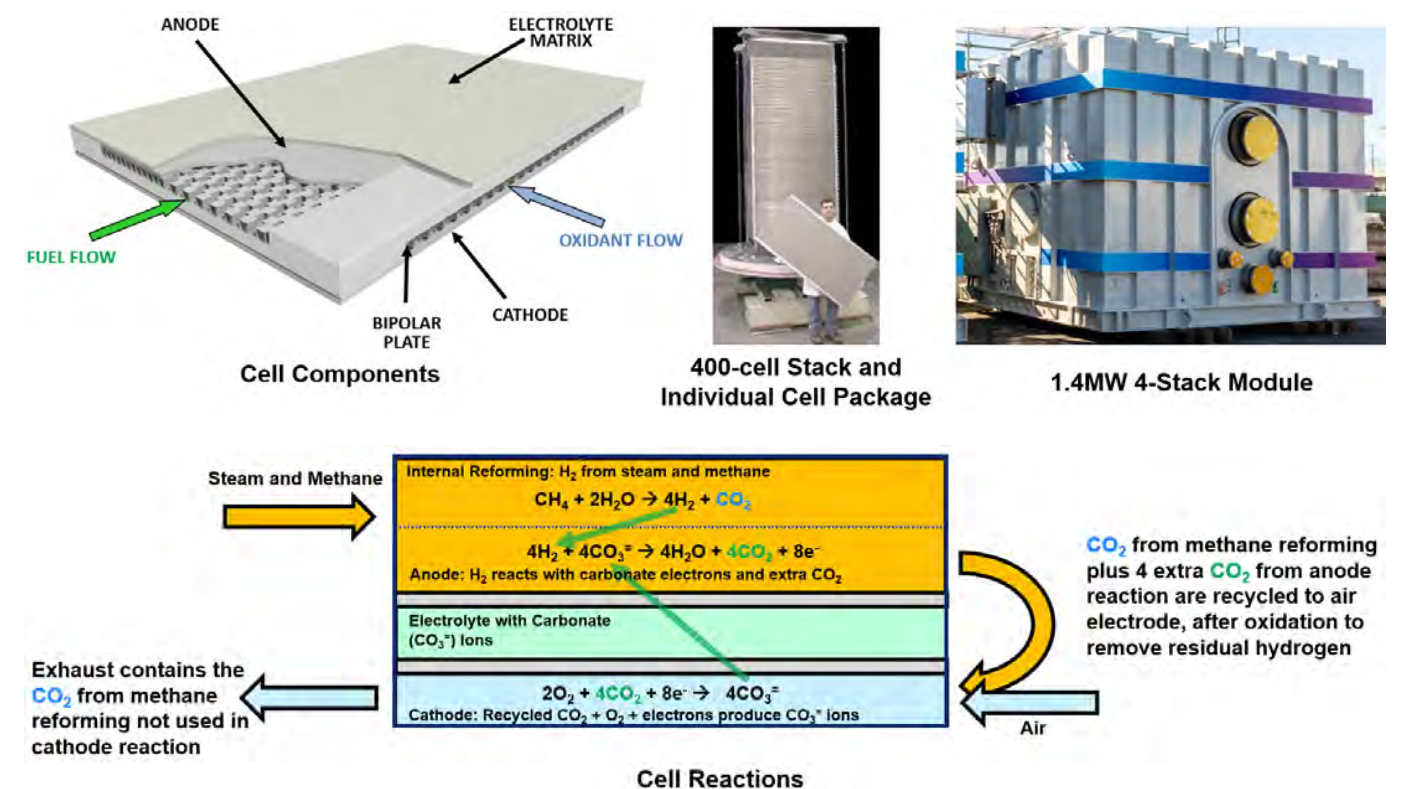

Carbonate stacks are made up of individual cell packages containing the fuel electrodes, air electrodes, and a porous ceramic matrix layer containing the carbonate ion electrolyte. The fuel electrodes in a carbonate stack also support the reforming of methane to hydrogen, which is then consumed by the fuel cell reaction to make power. The reforming reaction will produce one molecule of carbon dioxide for each molecule of methane fuel. The fuel electrode reaction also produces additional carbon dioxide (four more molecules for each methane input), which is recycled back to the air electrodes, where the extra four molecules are consumed. The recycle system is part of the mechanical balance of plant of a carbonate fuel cell powerplant. Extracting carbon dioxide from this recycle stream and replacing it with external carbon dioxide from a flue gas is the key to the carbonate fuel cell carbon capture approach.

Using carbonate fuel cells for carbon capture involves adding additional process equipment to the powerplant mechanical balance of plant, as illustrated below. In a standard carbonate powerplant, CO₂ produced at the anode is recycled back to the cathode to provide the CO₂ needed by the air electrodes. If the concentrated CO₂ in the anode exhaust stream is extracted from the system and not recycled back to the cathode, an external source of CO₂ can support the cathode reaction. This external source can be the exhaust from another powerplant or an industrial source. The dilute CO₂ in the external flue gas will be reacted at the fuel cell cathodes and transferred to the anode stream, from which it can be easily separated for sequestration or utilization.

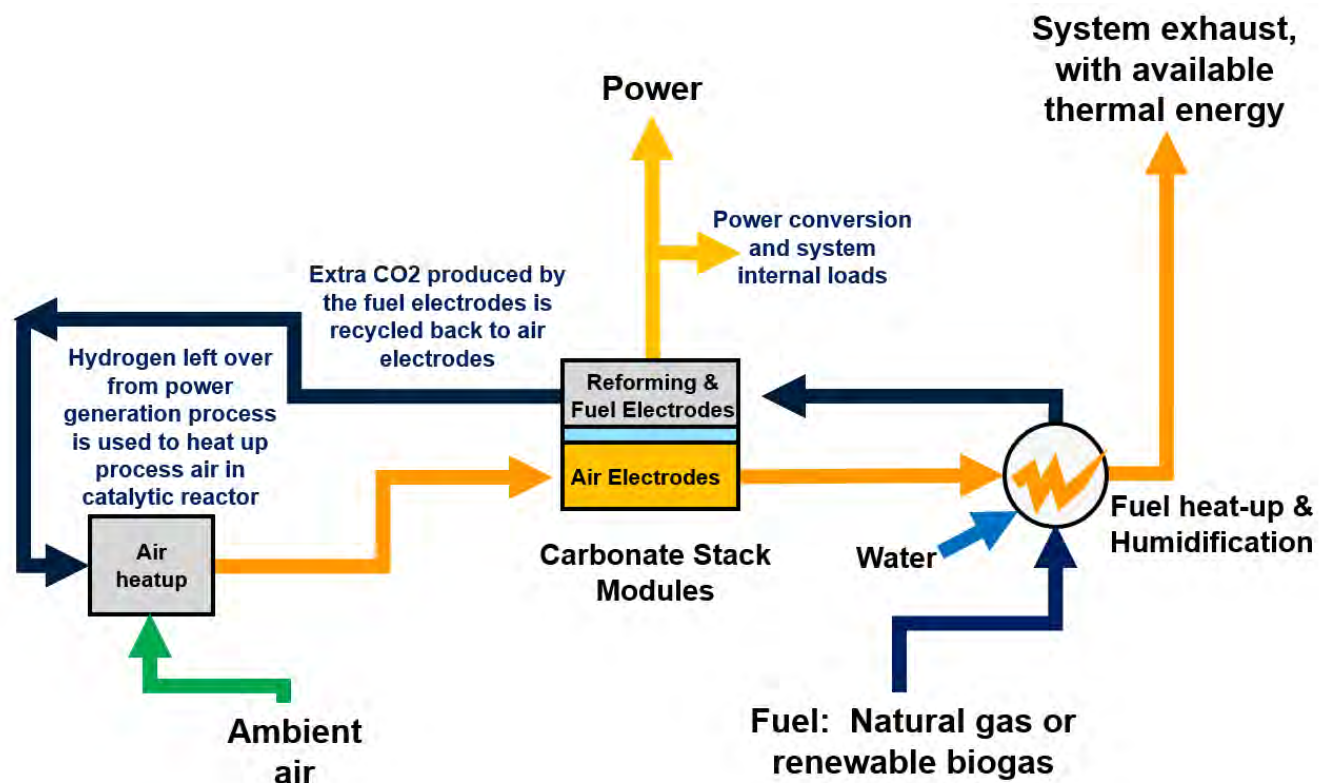

Standard System

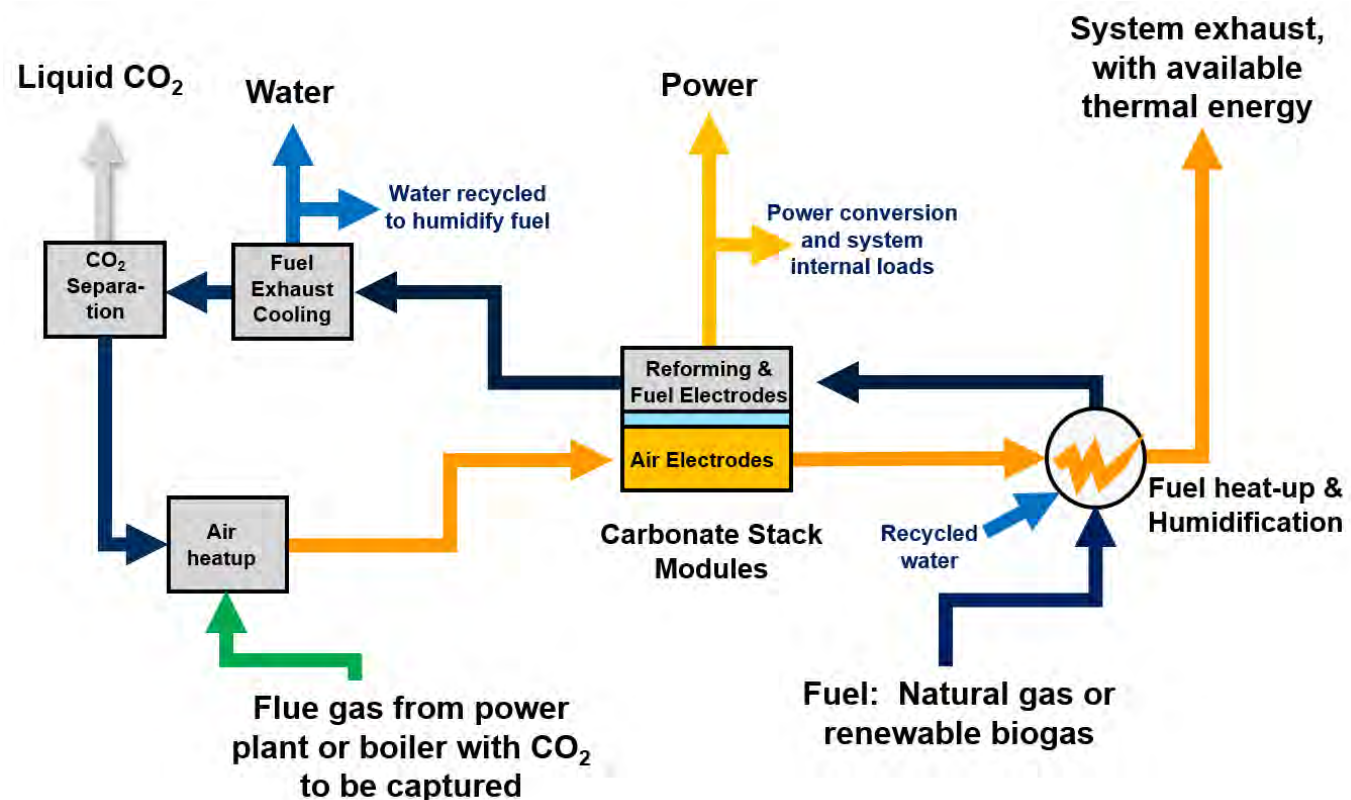

Carbon Capture Modification

The size of the carbonate powerplant required to capture CO₂ from a specific source depends on the size of the source and the CO₂ emission rate. A 2.8MW carbonate fuel cell powerplant during normal power operation is transferring about 3200 kg of CO₂ per hour from the cathode to anode streams in the stack modules. In carbon capture mode, this system could capture and purify up to 2300 kg per hour of external CO₂ in addition to the CO₂ from the powerplant fuel input. The amount of capture at various fuel cell powerplant sizes is shown in this figure:

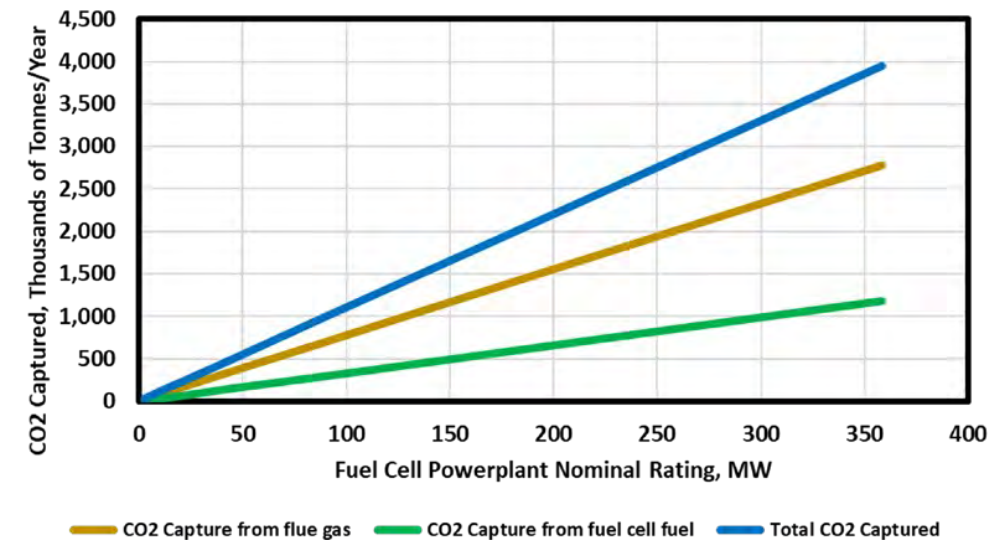

The modular nature of the fuel cell system allows a wide range of system applications. Powerplants rated at single to tens of MW output can be used for industrial applications, such as capture from boilers, and are particularly attractive in industries that use carbon dioxide, where on-site combined heat, power, and CO₂ production can provide cost, sustainability, and resiliency advantages. Powerplants rated at 100's of MW can be used to capture CO₂ from petrochemical or large power generation systems. These large-scale carbonate carbon capture systems will ultimately be specially designed with larger scale balance of plant systems than today's commercial powerplant products. In the near term, smaller scale capture systems

have been configured based on the current generation of commercially available 1.4MW stack modules. Large fuel cell systems based on multiple powerplants have become common in bulk power generation applications. The largest such system so far is a 59 MW system using forty-two 1.4MW fuel cell modules located in Hwasung City, South Korea, shown below.

As FuelCell Energy develops early projects using currently available fuel cell equipment, the company is working with ExxonMobil in a joint development effort to optimize the performance of the fuel cells in carbon capture mode, and to develop advanced stack module and system designs to address large scale carbon capture applications.





HEIRLOOM'S DIRECT AIR CAPTURE TECHNOLOGY

HEIRLOOM

SUMMARY

Heirloom's Direct Air Capture (DAC) technology rapidly accelerates the natural ability of limestone to absorb CO₂ from the air from a timespan of years to days. The technology removes atmospheric CO₂ in a way that is permanent, low-cost and scalable. Founded in 2020 by the world's leading experts in CO₂ removal and serial deep-tech entrepreneurs, Heirloom is currently operating one of a very small number of DAC facilities in the United

States that is permanently storing CO₂, and its customers are the world's biggest buyers of carbon removal including Microsoft, Stripe, Klarna, Shopify and more. Heirloom is backed by some of the world's best climate investors including Breakthrough Energy Ventures, Microsoft, Lower Carbon Capital, Prelude, Carbon Direct, Ahren Innovation Capital, Marc Benioff's Time Ventures, Alexis Ohanian's 776 and Breyer Capital.

BENEFITS

Heirloom's technology is designed to drive down the cost of CO₂ removal to achieve gigaton scale quickly. A number of features drive this cost reduction, including:

- Low-cost inputs – Heirloom uses limestone to capture CO₂ from the atmosphere. Making up four percent of the Earth's surface and costing just \$10-50 a ton, limestone is more abundant, far less expensive, and easier to source than the engineered materials used by other DAC technologies.
- Modular design – Heirloom's carbon removal facilities are built for simple, mass manufacturing and have independent components and processes that can be optimized over time.
- Powered by data – Heirloom's technology gathers millions of data points every month on parameters that govern how quickly our technology can pull CO₂ from the atmosphere. This data enables us to continually train the algorithms that power our automated facilities to optimize their uptake of CO₂ – further increasing our output and reducing cost.

DESCRIPTION

Heirloom was founded in 2020 by Shashank Samala, the former co-founder of industrial automation software provider Tempo, who grew up in southeast India where he saw first-hand how those contributing the least to climate change were most impacted by its effects.

Wanting to scale a negative emissions technology that had the capability of scaling to sequester billions of tons of CO₂ each year, Shashank co-founded Heirloom in 2020 with Dr Noah McQueen, a researcher in the lab of Professor Jen Wilcox at the University of Pennsylvania.

Heirloom's technology uses the world's second most abundant material, limestone (calcium carbonate - CaCO₃) to capture carbon dioxide (CO₂) directly from the atmosphere, and then permanently and safely stores that CO₂ so that it doesn't return to the air. The company's mission is to remove 1 billion tons of carbon from the atmosphere by 2035, a figure which represents 20% of today's annual U.S. emissions and 10% of global carbon removal needed annually by 2050.

Limestone is made up of calcium oxide (CaO) and CO₂. When CO₂ is removed from the limestone, the calcium oxide wants to return to its natural limestone state. It becomes "thirsty" for CO₂ and acts like a sponge – pulling CO₂ from the atmosphere. Heirloom's technology accelerates this natural property of limestone, reducing the time it takes to absorb CO₂ from years to just three days.

The process works by heating limestone mineral powder in a renewable-energy powered kiln to remove the CO₂. The powder is then spread onto vertically-stacked trays where well-trained algorithms inform how to treat the limestone to optimize its ability to uptake CO₂. The limestone powder is looped through the system to continuously sponge CO₂ from the atmosphere - a cyclic process that not only reduces costs but also reduces how much mineral must be mined.

Heirloom is backed by some of the most well-known climate investors in the world, including Breakthrough Energy Ventures, Microsoft, Lower Carbon Capital, Prelude, Carbon Direct, Ahren Innovation Capital, Marc Benioff's Time Ventures, Alexis Ohanian's 776 and Breyer Capital. The company raised a \$53 million Series A in 2022, and is currently operating America's only operational DAC facility. Heirloom has sold carbon removal credits to Stripe, Klarna and Shopify, and recently signed a deal with Microsoft to deliver permanent carbon removal credits in the coming years.

In early 2023, Heirloom achieved a milestone by removing CO₂ from the atmosphere and permanently storing it in concrete for the first time ever. This first-of-its-kind application is significant because concrete is currently the only permanent storage vehicle available for CO₂ removed from the atmosphere in the United States. Concrete storage of atmospheric CO₂ will enable companies like Heirloom to advance technologies and begin to scale without waiting for other storage options – such as underground wells – to open up.



HUANENG CLEAN ENERGY RESEARCH INSTITUTE

HUANENG CLEAN ENERGY RESEARCH INSTITUTE

SUMMARY

China Huaneng Clean Energy Research Institute (CERI) has developed a variety of high-performance carbon capture technologies such as the advanced amine absorbent, slurry-based CO₂ capture absorbent, and next-generation phase change CO₂ capture absorbent. We have established independent intellectual property rights and a complete set of technology system for CO₂ capture in coal/gas power plants, and technologies have been demonstrated in multiple international and domestic carbon capture plants. CERI has built up the first-tier research and development platforms, such as the "National Key Laboratory of High-Efficiency Flexible Coal Power Generation and Carbon Capture Utilization and Storage", "Beijing Key Laboratory for Carbon Dioxide Capture and Treatment" and the partner of "International Carbon Capture Testing Center Network Platform (ITCN)".

CERI has demonstrated its carbon capture technologies in over 16 coal or gas fired power plants. We have validated our commercial advanced amine technology for over

20,000 hours operation in the 120,000 tonne/annum post-combustion CO₂ capture facility in Shanghai Shidongkou coal-fired power plant. We are constructing the world's largest post-combustion CO₂ capture and storage project 1,500,000 tonne/annum CO₂ from Huaneng Zhengning Energy Base, a 10 GW multi-energy infrastructure in the west of China. We are exporting our CO₂ capture technology overseas to build the 110,000 tonne/annum CO₂ capture project retrofitting to Millmerran coal-fired power plant in Queensland in Australia.

CERI can provide a broad spectrum of engineering services including collaboration in R&D for CO₂ capture solvent development, process engineering design, high-efficiency equipment design and procurement, plant debugging and commissioning, catalyst design and synthesis for CO₂ utilization, engineering design for desulphurization (deSO_x), denitrification (deNO_x), and CO₂ storage in saline aquifers.

BENEFITS

- Built up on R&D, we can realize the seamless connection from research, to engineering demonstration, and to commercial operation
- Broad spectrum of engineering capabilities from technology engineering design, equipment procurement, construction, commissioning and operation
- Extensive experience and skills in commercial carbon capture technology, from the Shanghai Shidongkou 120,000 tonne/annum CO₂ capture demonstration facility built in 2009, to the scale-up project of 1,500,000 tonne/annum CCS project which is in construction in the Huaneng Zhengning Energy Base in west of China
- Leading the development of the international standard ISO/WD27927 "Key performance parameters and characterization methods of absorption liquids for post-combustion CO₂ capture"
- We have established close collaboration with overseas academics and industries, from "China US Clean Energy Research Center", "China Europe CCUS Technology Cooperation", and "China Italy CCS Technology Cooperation", and "International Carbon Capture Testing Center Network Platform (ITCN)"

DESCRIPTION

CERI'S CO₂ CAPTURE TECHNOLOGIES

CERI has developed a broad spectrum of CO₂ capture technologies and systems built for the coal and gas-fired power plants, waste-to-energy plants, steel plants and refinery plants. We started R&D and engineering demonstration back in 2006. With over 16 years of experience, we expertise in providing engineering services including the development of high-performance CO₂ solvents, solvent recovery and purification technology, carbon capture process design and optimization, high-efficiency equipment design, power plant integrated design optimization, engineering design, construction, commissioning and operation. Those are not limited to post-combustion CO₂ capture, but can also apply to pre-combustion CO₂ capture, CO₂ utilization and CO₂ sequestration.

The followings are CERI's cutting edge commercial CO₂ capture technologies:

- **Advanced Amine Absorbent.** CERI has developed a series of commercial blended amines solvents named HNC-1~HNC-5. The advanced amine, HNC-5 solvent has been validated for more than 20,000 hours in Shanghai Shidongkou 120,000 tonne/annum CO₂ capture facility, with the solvent loss rate of 40% of conventional amine and regeneration energy below 2.8 GJ/tCO₂, reducing 20% CO₂ capture cost.
- **Next-generation Amine Absorbent.** CERI is developing the next generation HNC-6 solvent technology incorporating higher cyclic loading faster reaction kinetics, low energy consumption, low solvent degradation, low corrosivity with attractive technical feasibility (viscosity, wettability) and environmentally benign benefits in terms of low toxicity and volatility.
- **Slurry-based CO₂ Absorbent.** CERI has developed potassium carbonate slurry-based CO₂ capture absorbent and process which is validated in the lab-scale pilot plant. The regeneration energy is 2.6GJ/tCO₂, absorbent cost is 20% that of conventional amine and solvent loss cost is 22%~50% that of MEA.

- **Next-generation Phase Change CO₂ Absorbent.** CERI has developed phase-change CO₂ absorbent that can realize the automatic phase separation of rich liquid after CO₂ absorption. The phase-change CO₂ absorbent was tested at the 1,000 tonne/annum phase-change carbon capture industrial device in Huaneng Changchun Thermal Power Plant. After CO₂ absorption, the self-concentrated biphasic CO₂ absorbent can split into two liquid/liquid phase by itself. Almost all absorbed CO₂ transfer into the rich phase (more than 95%). Only the rich phase is transferred to the regeneration system for CO₂ desorption. Results show a regeneration energy reduction up to 40% than the conventional amine MEA.

CERI is currently the leading CO₂ capture technology provider in China, and has accumulated a wealth of intellectual property achievements such as patents, standards, research and industrial papers through over 16 years of R&D and technology demonstration. We have been awarded with top-tier prizes in China's Electric Power Science and Technology Award, National Energy Science and Technology Award, Outstanding Contribution Award in US CCUS Technology Award, United Nations Environmental-Friendly Demonstration Project Award, etc.

We have built a number of international and domestic CO₂ capture facilities, spanning from Beijing Gaobeidian coal-fired power 3,000 tonne/annum CO₂ capture facility, Shanghai Shidongkou coal-fired power 120,000 tonne/annum post combustion CO₂ capture facility, Tianjin GreenGen IGCC 100,000 tonne/annum pre-combustion CO₂ capture facility, Taiyuan steel plant 45,000 tonne/annum industrial CO₂ capture project, Zhejiang Pinghu waste-to-energy plant CO₂ capture facility, to the future Australia Glencore's Surat Basin 110,000 tonne/annum CCS Project and Huaneng Longdong 1.5 million tonne/annum CCUS project.

HIGHLIGHTED CO₂ CAPTURE PROJECTS DEVELOPED BY CERl

CERl has been actively exploring high-efficiency, cost-effective carbon capture technologies, and built a number of projects, both in China and overseas. The timeline of CERl carbon capture project development is shown in the diagram on the previous page.

In July 2008, China's first post-combustion CO₂ capture facility, capturing 3,000 tonne/year CO₂, commenced operation in Huaneng Beijing Gaobeidian Power Plant. The facility is independently designed and constructed by CERl. This project marks the first pilot test of CO₂ capture technology in coal-fired power in China.

In 2009, CERl scaled up its engineering expertise to build a 120,000 CO₂ capturing facility in Shanghai Shidongkou No.2 ultra-supercritical coal-fired power plant. It is well known as a pioneer CCUS project in China, and it was the world's largest post-combustion CO₂ capture project retrofitted to a coal-fired power plant at that time. The energy consumption of this CO₂ capture facility was <2.8

GJ/tonne CO₂ at the capture ratio over 90%, a significant improvement over the first-generation amine solvent using MEA. Today, Shidongkou Post-combustion Carbon Capture Project has achieved over 22,000 operation hours, the world's longest operating post-combustion capture plant.

The project was the first one to show that the cost of post-combustion CO₂ capture can be far below \$100 back in 2009. The construction was completed in less than 7 months which showed the China speed of construction, a pathway for cost reduction in CAPEX.

In 2013, CERl built China's first gas-fired carbon capture pilot plant in Beijing, capturing 1,000 tonne/annum CO₂. This facility became the key testing platform for the validation of the capture technologies we developed in the lab.

In 2016, CERl started operation of the first pre-combustion CO₂ capture unit in China. This CO₂ capture facility is the world's largest and, capable of conducting experiments under flexible loads and operating conditions.

| ITEMS | SHANGHAI SHIDONGKOU COAL-FIRED POWER CO ₂ CAPTURE FACILITY | IGCC PRE-COMBUSTION CARBON CAPTURE FACILITY | HAINAN INTERNATIONAL CO ₂ CAPTURE TEST PLATFORM | HUANENG LONGDONG ENERGY BASE CCS PROJECT |
|---------------------------------|--|--|--|---|
| Capture Process | Post combustion | Pre-Combustion | Post combustion | Post combustion |
| Feature | Supercritical coal-fired power plant, CO ₂ 12-15% in flue gas | IGCC based full chain CCS | NG combustion flue gas, CO ₂ ~4% in flue gas | Advanced ultra-supercritical coal-fired power plant, CO ₂ 10-14% in flue gas |
| Scale | 120,000tpa CO ₂ | 100,000tpa CO ₂ (30MW _{th}) | 2,000tpa CO ₂ | 1,500,000tpa CO ₂ |
| Regeneration Energy consumption | <2.8GJ/t CO ₂ | <2.3GJ/t CO ₂ | 3.0GJ/tCO ₂ | <2.3GJ/t CO ₂ |
| Capture Ratio | >85% | - | >90% | >90% |
| CO ₂ Purity | Food Grade, >99.997% | - | Industrial use | |
| Others | Largest PCC unit then, have been operating 10 years continually | - | Open for international collaboration for technology testing and verification | Will be the world's largest PCC plant when built |
| | Capture cost 300-400RMB/t CO ₂ | - | Real NGCC flue gas condition | Captured CO ₂ for EOR and dedicated geological storage |



CCS PROJECTS IN DEVELOPMENT



1. Shanghai Shidongkou 120,000 tonne/annum phase-change CO₂ capture project.

This project is to scale up CERl's phase-change CO₂ capture technology at 120,000 tonne/annum capacity, and to complete industrial verification and reach a performance target at ≤2.3GJ/tCO₂ regenerated energy and ≤1.0kg/tCO₂ solvent loss. The phase change CO₂ capture technology was successfully demonstrated at the 1,000 tonne/annum phase-change carbon capture pilot plant in Huaneng Changchun Thermal Power Plant in 2020.



2. Huaneng international CO₂ capture test platform for Natural Gas Combined Cycle power plant in Hainan Island, China

The 2,000 tonne/annum international CO₂ capture testing platform uses real flue gas from the Natural Gas Combined Cycle (NGCC) power plant located in Yangpu, Hainan Island, China. Hainan has 30-day visa-free access for international visitors. This enables international collaboration for testing and validating carbon capture technologies. Huaneng Clean Energy Research Institute is a partner of International Test Center Network, and the only one in China.



3. Glencore Surat Basin 110,000 tonne/annum CCS Project in Queensland Australia

We are developing the post-combustion CO₂ capture project retrofitting to the Millmerran coal-fired power plant in Queensland, Australia. The project can capture 110,000 tonne/annum CO₂. It will build a demonstration scale but also scalable post-combustion CO₂ capture plant. Once built, it will be the first commercial post-combustion CO₂ capture project in Australia, and first China post combustion CO₂ capture technology export overseas.



4. Huaneng Longdong 1,500,000 Tonne/Annum CCUS Project

This million-tonne scale CCUS project is in construction. Once built by 2024, this project will become China's first million-tonne carbon capture and storage facility in the power sector, and the largest post-combustion CO₂ capture facility in the world. This project deploys China Huaneng's next-generation HNC series CO₂ capture technology. CO₂ will be captured from the slipstream of Unit 1 of the 2x1,000 MW ultra-supercritical coal-fired power plant, at the newly build China Huaneng Longdong Energy Base in Northwest China. The CCUS project will reduce 1.5 million tonnes per annum CO₂ emission, at a regeneration heat duty below 2.3 GJ/tonne CO₂, and CO₂ capture cost is around RMB 220 per tonne CO₂ captured (<USD \$35). The captured CO₂ will be transported via pipeline in the supercritical phase. Around 1 million tonne per annum CO₂ will be stored via dedicated geological storage in the nearby geological sites, and 0.5 million tonnes per annum CO₂ will be sent to CNPC oil fields for enhanced oil recovery.

The project will present a revolutionary low-cost decarbonization option for coal-fired power generation, as well as a flexible operation model for the peak-load regulating coal-fired power unit and CCS working along with the increasing penetration of renewable energy in power generation. The Longdong Energy Base itself is a multi-energy infrastructure with 8 GW renewables and 2 GW ultra-supercritical coal fired power.



NAME OF TECHNOLOGY HONEYWELL

SUMMARY

A PATH TO CARBON NEUTRALITY STARTS TODAY

With a global focus on combatting climate change, industry leaders are aggressively seeking technology solutions that limit greenhouse gas emissions.

This is especially critical for carbon-intensive industrial markets such as power, steel, cement, refining, petrochemicals, hydrogen and natural gas processing where reducing environmental impact has been difficult.

There are many avenues a company can take to meet sustainability goals – and a drive towards carbon neutrality is gaining prominence as a key driver of meeting commitments. While many companies are taking the first steps towards carbon neutrality with more energy-efficient machinery and processes, technology supporting these initiatives is continuously evolving and improving, and companies need to keep up.

CARBON CAPTURE TECHNOLOGIES AND THEIR ROLE IN SUSTAINABLE OPERATIONS

Deciding what sustainability initiatives to implement to start your company's journey towards more environment-friendly processes can be daunting. From making commitments to plant a certain number of trees to implementing energy-efficient processes, there are multiple pathways leading towards more carbon-neutral operations, some of which can be integrated immediately, but others require longer-term planning.

Carbon capture, utilization and storage (CCUS) is a key technology for reducing greenhouse gas emissions. According to the International Energy Agency, carbon capture capacity must increase more than 20 times to enable the capture of 840 Mtpa CO₂ by 2030 to meet global emission goals.

Incorporating carbon capture technologies into production is an effective path industrial companies can take to reduce their environmental impact and prevent harmful emissions from entering the atmosphere. However, carbon capture is a broad and complex field, requiring in-depth knowledge of both the technology and industry to effectively execute.

BENEFITS

- Significant track record in Carbon Capture with vast technology portfolio
- Honeywell has a vast portfolio of carbon capture technologies that help support industry leaders to move towards a lower carbon footprint. Out of experts can work with you to determine the best solution to meeting your CO₂ emission goals

DESCRIPTION

CHALLENGES FOR INDUSTRY LEADERS

- Legal, regulatory, and financial frameworks need to continue progressing
- Large scale projects remain a significant hurdle due to energy requirements
- Full ecosystem that embodies all elements of carbon capture to support fast-moving

CHEMICAL SOLVENTS

AmineGuard™ & Amine Guard FS Process

MEA based system that is mature, reliable, and easy to operate, with >600 units licensed and in operation. Removes CO₂ from natural gas, syngas, & blast furnace gas.

Benfield™

Inorganic solvent based system for pressurized gas streams (natural gas, syngas, ethylene oxide) >650 units in operation.

Advanced Solvent for Carbon Capture (ASCC)

Second Generation amine based system targeting hard to abate flue gases from power, steel, cement, natural gas, industrials, refining & petrochemical industries.

PHYSICAL SOLVENTS

SeparALL™ Process

Physical Solvent (non toxic & non flammable) for high pressure gasification streams selectively removes H₂S/CO₂ utilizing Selexol™ solvent.

ADSORBENTS

Polybed™ Pressure Swing Adsorption (PSA) System

A process that utilizes a series of pressurization and depressurization cycles with adsorbents and cycles for H₂ purification and CO₂ rejection (>1150 units, 3 operating in CO₂ application). PSAs are often paired with other separation technologies to optimize CO₂ capture capabilities.

CRYOGENICS & MEMBRANES

Separex™ Membrane Systems

High, partial-pressure CO₂ capture, significant experience in onshore & offshore capturing and sequestering (>300 units) Requires minimal rotating equipment, no chemical reagent replacement, and minimal maintenance, Designed for operational simplicity.

Ortloff CO₂ Fractionation

Solvent-free option, all-electric process (no steam required) with fewer subsystems and a smaller footprint than a solvent system, delivers CO₂ as a high purity liquid product.

TECHNOLOGY DELIVERY

Honeywell can provide technology as initial studies to define best path forward, transfers the technology through license, engineering, key mechanical equipment, solvent, adsorbents, services and modular supply.

PRE COMBUSTION CARBON CAPTURE SOLUTIONS

Honeywell UOP has provided innovative hydrogen processing solutions to refineries and other industries for five decades. Today, refineries can implement Honeywell H₂ Solutions at scale and low cost, achieving significant sustainability impact.

Honeywell H₂ Solutions include multiple carbon capture flow schemes you can tailor to your requirements for hydrogen yield, hydrogen purity, CO₂ purity, steam use, or capital and operating cost needs.

Ready today, Honeywell H₂ Solutions is a suite of proven carbon capture technologies to help you meet stringent emissions goals and gain fast, profitable entry into the growing hydrogen economy.

The fact is, hydrogen is a clean-burning fuel that can decarbonize hard-to-abate segments as long as it's produced using a low-carbon route. Low-carbon hydrogen can be an economical solution for decarbonizing petrochemical, refining, transportation, and power generation businesses.

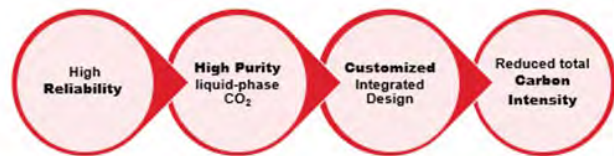
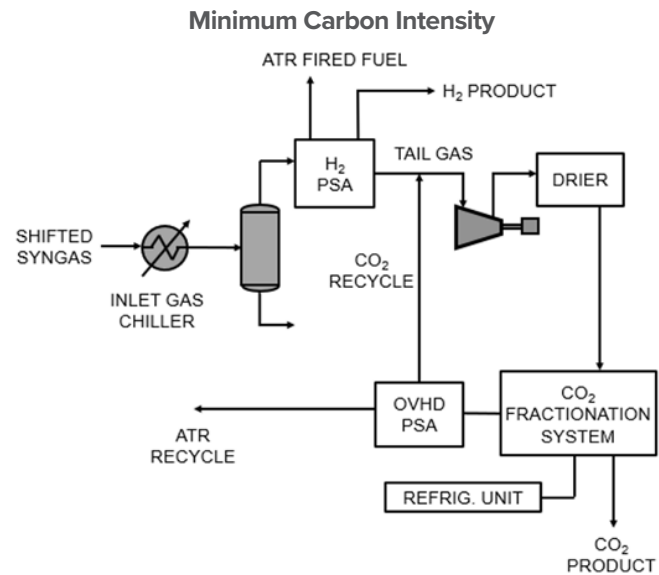

PRECOMBUSTION SOLUTIONS – OPTIMIZED THROUGH COMBINED PSA AND CRYOGENIC FRACTIONATION TECHNOLOGY POLYBED™

Pressure Swing Adsorption (PSA) System

- Selectively separates high purity Hydrogen from syngas streams to minimize carbon slip into the product and maximize production rate. PSAs selective for CO₂ are also used within the optimized Pre-combustion flow scheme to minimize CO₂ emissions from the process
- Field performance tests prove the performance of PSA systems with an on-stream factor of 99.8+% and specified adsorbent life of more than 20 years.
- PSAs product streams from a Hydrogen Production Unit can deliver Hydrogen with minimal pressure drop and at a Hydrogen purity of up to 99.99% with the ability to provide lower concentrations as needed

Ortloff CO₂ Fractionation

- A solvent-free option, all-electric process (no steam required) with fewer subsystems and a smaller footprint than a solvent system for
- Proprietary Mixed Refrigerant and design minimizes equipment count and size of this Cryogenic Fractionation system
- Ability to manage temperature at point of separation within a tight range enables very effective first-pass CO₂ recovery

CO₂ produced to meet project off-take requirements and can act as a single unit operation for separation & liquefaction **Optimized Flow Scheme.**

- Leverages PSA selectivity to produce Carbon-Free Hydrogen product and Hydrogen fuel streams
- First-pass CO₂ recovery optimized for PSA tail gas stream
- Exhausts the CO₂ at the CO₂ Product stream, as any carbon molecules not captured in the first pass are recycled through the process to extinction
- Flexible design provides the ability to trade off Capital and Operating costs with expected process emissions

PROOF POINTS

Wabash Valley Resources

- Selected to provide integration of modular MOLSIV, Modular Ortloff CO₂ Fractionation System, & Modular PSA
- Demonstrates large scale commercially viable clean H₂ and CCUS projects under current US regulatory and policy framework

XOM Baytown

- Honeywell UOP's carbon capture technology will be integrated into the design of ExxonMobil's low-carbon hydrogen production facility and enable it to capture more than 98% (1) of associated CO₂ emissions.
- ExxonMobil will deploy one of Honeywell's carbon capture technologies – Honeywell's CO₂ Fractionation and Hydrogen Purification System - at its integrated complex in Baytown, Texas. This technology is expected to enable ExxonMobil to capture about 7 million tons of carbon dioxide (CO₂) per year, the equivalent of the emission of 1.5 million of automobiles for one year (2).
- High purity H₂ produced from Pressure Swing Adsorption and Polysep™ Membrane Technologies
- ExxonMobil's H₂ production project's goal is to reduce, by up to 30%, Scope 1 and Scope 2 emissions at their Baytown facility (3).

POST-COMBUSTION ADVANCED SOLVENT TECHNOLOGY UNLOCKS POTENTIAL

In collaboration with the University of Texas, Honeywell is proud to offer a new advanced solvent technology to lower CO₂ emissions generated from combustion flue gases in hard-to-abate industries, such as power, steel, cement, refining, petrochemical and other industrial plants.

Utilizing an advanced solvent, this point source CO₂ removal technology enables CO₂ to be captured at a lower cost through greater efficiency using smaller equipment. This creates viable project economics today as countries across the globe progress to meet their sustainability targets (4). It can be retrofitted within existing plants or included as part of a new installation.

PROOF POINTS

- Over 20 years of development at the University of Texas at Austin
- Pilot plant testing since 2006 with CO₂ concentrations from 4-20 vol%
- Flue gas flow rates of 350-600 CFM at pilot plant

DEMONSTRATION AT NATIONAL CARBON CAPTURE CENTER

- 0.5 MW coal fired flue gas, 1500 CFM flow with 8tpd CO₂ capture
- CO₂ Concentrations tested @ 12% (2018), 4% (2019), & 4% (2023)
- Solvent performs well with oxygen up to 15 vol%
- Three campaigns completed with 8000+ hours of testing

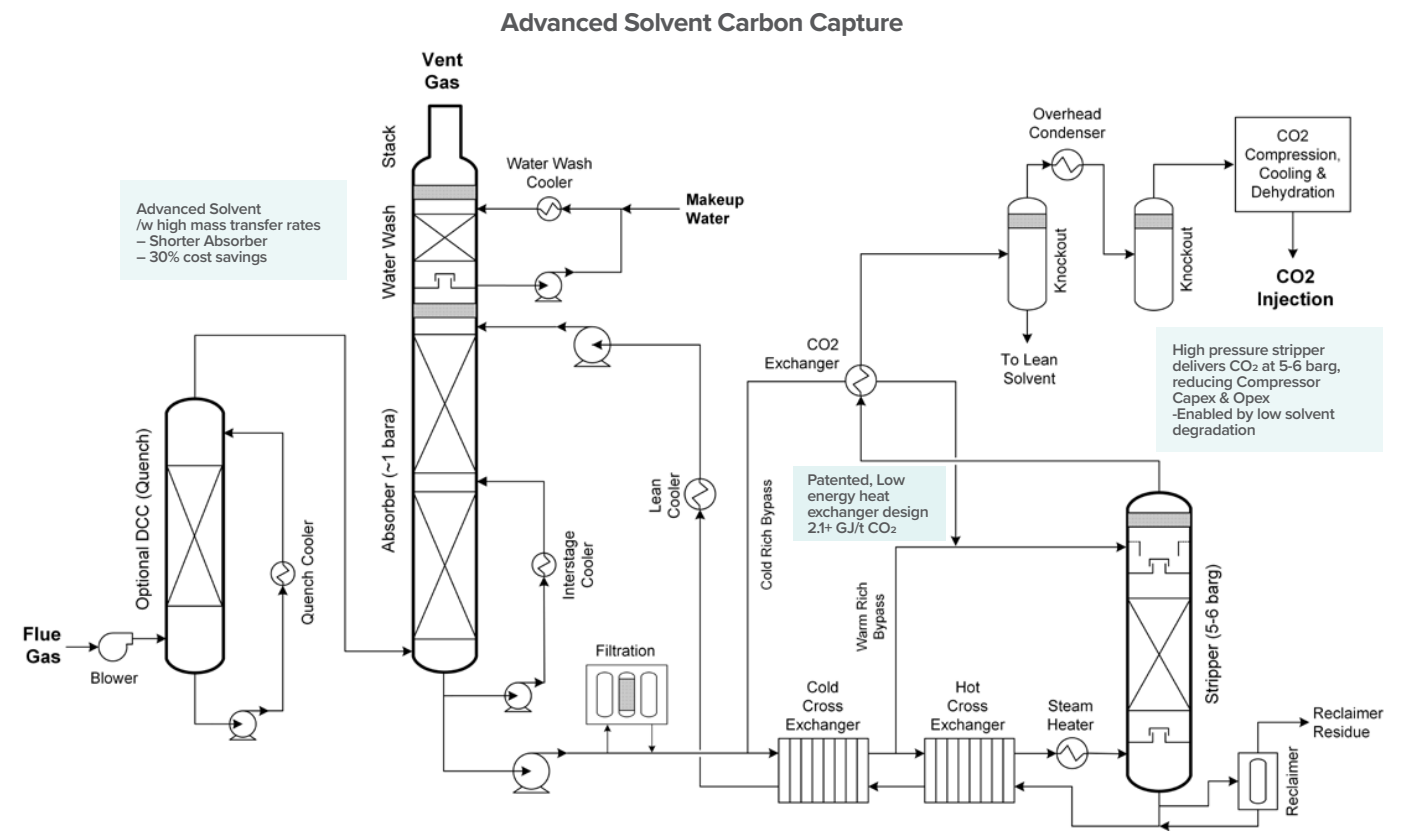

1. CO₂ equivalent emissions is a calculated value based on the combined carbon compounds emitted from the Hydrogen production and Carbon Capture equipment plus the combined carbon compounds in the H₂ product.
2. Based on the EPA's GHG equivalency calculator comparing nearly 7 million tons of CO₂ per year with gasoline-powered passenger vehicles on the road.
3. Based on press release issued Feb 15, 2023, announcing HON H₂ tech in Exxon Baytown facility.
4. Lower cost of CO₂ capture based on comparing estimated capital and operating costs of this solution against other conventional amine solvents in same applications. CO₂ pricing considers current policies of \$50/ton tax credit (USA per IRS Section 45Q for permanent storage) and \$60/ton (UK and Europe – approximate averages from August 2021 through country/regional Emission Trading Systems and as reported by IHS Markit).



INTEGRATION OF CO₂ CAPTURE AND SEQUESTRATION OR USE

K2-CO₂

SUMMARY

K2-CO₂ delivers fully integrated turnkey Carbon Capture Use & Sequestration (CCUS) solutions targeting small and medium scale industrial emitters.

Our portfolio includes turnkey solutions to satisfy from the exit of combustion source to the exhaust stack including Carbon Capture integrated with flue gas conditioning, waste heat recovery, and reuse or sequestration.

These solutions integrate into an existing process without impacting the production, resulting in a reduction of environmental emissions, overall energy impact, and CO₂ footprint.

Our team leverages its extensive experience as industrial flue gas treatment integrators to offer a safe, energy-efficient, “bolt-on” carbon capture system utilizing Hot Potassium Carbonate (HPC) solvent with the needed conditioning for sequestration or reuse.

The HPC-solvent process for CO₂ capture, licensed by Giammarco Vetrocoke, is used globally in industries such as chemical plants with high CO₂ concentrations in the flue gas: K2-CO₂ has extended the usefulness to lower CO₂ concentrations, making it suitable for most combustion-derived flue gas.

BENEFITS

- **No Upstream Process Modifications:** Our systems integrate into existing processes without upstream modification of conditions or fuel required and include Use and/or Storage, providing tailored solutions to the unique process and site.
- **Energy Efficient:** Energy demands for heating/cooling and expansion/compression are minimized through energy reuse throughout the process.
- **Cost Effective:** Minimal changes to combustion process, waste heat recovery, and solvent regeneration provide a cost-effective solution for CCUS in small to medium size emitters.
- **Continuous Compliance:** Highly effective air pollution control technology is integrated for other flue gas pollutants.

- **Safe and Environmentally Friendly:** Hot Potassium Carbonate (HPC) is a non-flammable, nontoxic, stable and inexpensive solvent, eliminating the need for harmful and corrosive amine-based capture processes.
- **Tailor-made:** CO₂ is delivered at conditions defined by the downstream process, easily reaching Food & Beverage quality if required

DESCRIPTION

The K2-CO₂ process comprises of a dry section and wet section connected in series.

The dry section comprises of the Air Pollution Control system and heat recovery stages to meet the heat needs required by the carbon capture process.

This section can utilize existing air pollution control equipment (dedusting, deSO_x, deNO_x) on-site with the integration of heat recovery stages or can be provided as new equipment. It must be noted that the flue gas can exit the system by bypassing the wet section via an exhaust stack to maintain continuous emission compliance in the event of an emergency or maintenance on the wet system.

The wet section comprises of a deSO_x process, CO₂ absorption, and CO₂ cooling and concentration.

The deSO_x process provides further removal of contaminants and additional conditioning of the flue gas stream to begin the CO₂ recovery process.

The absorption section, utilizing the well-known carbon capture technology of Hot Potassium Carbonate (HPC), absorbs CO₂ from the flue gas stream into the HPC water solution. The remaining flue gases, which have already been treated in the dry section, are emitted to the atmosphere.

The CO₂-rich HPC solution is then heated to release the highly concentrated CO₂ product in a stripping process. The HPC solution is regenerated and injected into the absorber in a loop system, requiring no continuous make-up of the solution.

The CO₂ is collected, conditioned, and sent for the chosen use or storage solution for the process. The captured CO₂ can be sent to the conditioning plant, designed to deliver the desired CO₂ quality, pressure and temperature for use or storage: underground, for enhanced oil recovery or mineralization.

The conditioning technology is adapted to the effective needs and can cover from simple storage/delivery in gas phase to purification and liquefaction or compression to supercritical conditions.

The K2-CO₂ HPC process is a classic absorption/stripping process but is operated at relatively low pressures (typically 0.5-5 barg) and integrates all possible heat recovery stages. The process is designed to have zero external heat needs, making it less energy-intensive than other CCUS technologies, including those utilizing a similar solvent or amine-based systems. It can be applied to a wide range of industrial processes such as glass, steel, biomass/waste incineration.

HPC technology has been chosen against amines for several reasons. These include that HPC solution is safe for people and the environment, non-volatile, stable, inexpensive, and based on a readily and worldwide available basic component that is not provided by a propriety source, manufacturer, or licensor.

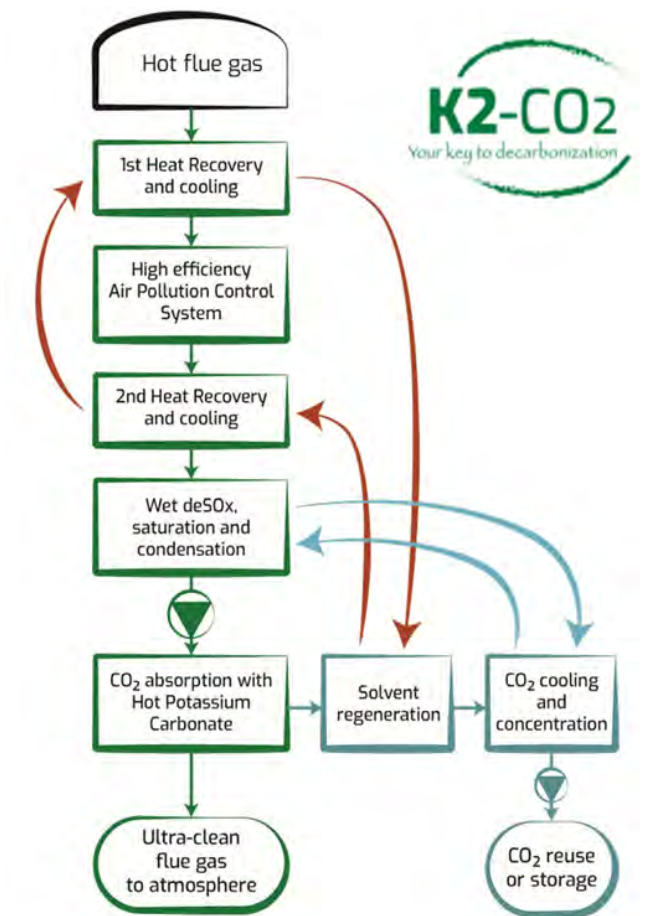

Schematic representation of K2-CO₂ typical process with indication of the main heat recovery stages; solution is always customized in function of the flue gas characteristics.

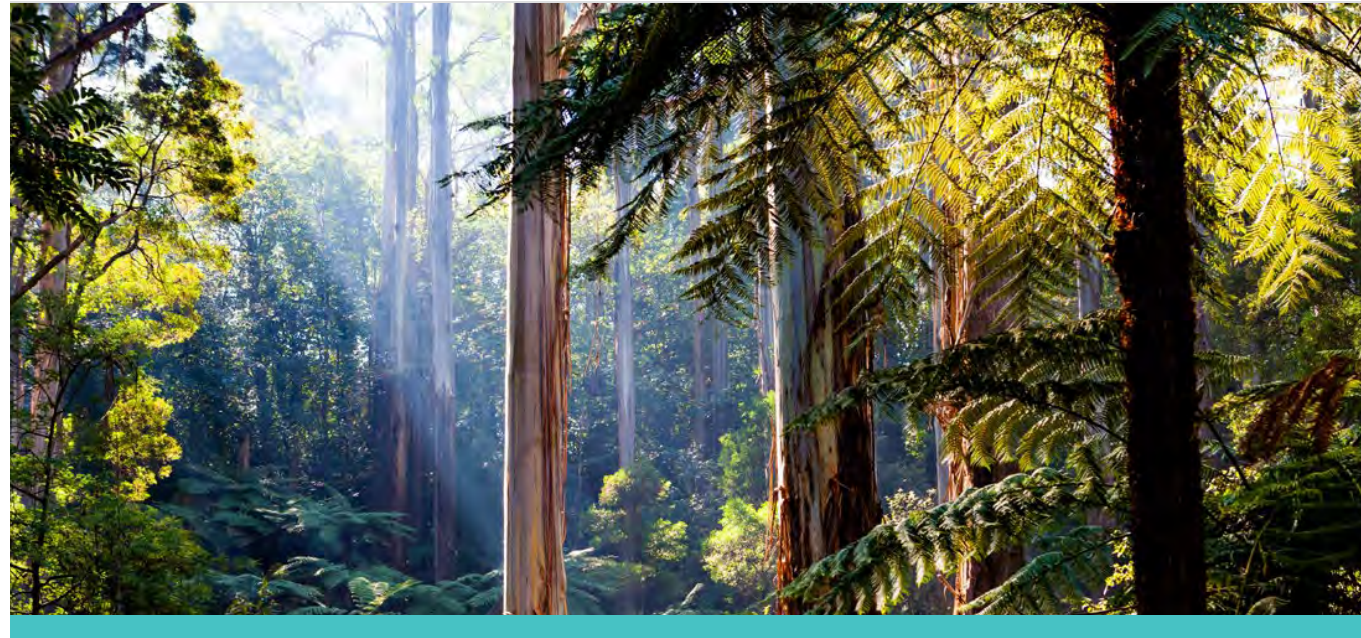

UNO MK 3 KC8 CAPTURE TECHNOLOGIES

SUMMARY

KC8 Capture Technologies is commercialising industry leading carbon capture technology that provides an affordable pathway to reduce greenhouse gas emissions from the use of fossil fuels and heavy industries around the world.

Our revolutionary UNO MK 3 technology utilizes a novel precipitating potassium carbonate (K_2CO_3) solvent, enabled through our patented solids tolerant absorber design. The formation of potassium bicarbonate solids in the system allows for greater solvent loading and lower circulating solvent volumes relative to both the Benfield process and conventional amine systems.

Further benefits of the novel solvent include a process size reduction, reducing both CAPEX cost and plant footprint, and decreased reboiler energy usage. These, along with other key advantages, allow for the UNO MK 3 technology to be built and operated at up to 50% lower overall costs compared to the best existing amine based equivalent.

Another key advantage of the precipitating potassium carbonate solvent is its tolerance of oxygen, SOx and NOx in the source flue gas. This opens up the technology

application range to difficult to abate sectors such as cement and steel, as well as energy sectors with additional challenges such as waste-to-energy and gas turbine-based power generation.

Major environmental and safety benefits are also realized with the UNO MK 3 technology, with its environmentally benign and non-volatile solvent alongside the lack of toxic by-product production proving to be of particular strategic advantage relative to its equivalent amine competitors. The solvent stability and non-volatility also reduces solvent loss due to degradation and eliminates the need for wash stages and reclamation units.

The UNO MK 3 has already been demonstrated at the pilot scale on industrial flue gasses, and two demonstration scale facilities are in late stage design, both of which are scheduled to begin operation in 2024. These will directly demonstrate the UNO MK 3 capabilities in both difficult to abate industrial and power sectors in their respective projects. Planned FEED studies are also predicted to confirm current estimates that the technology can achieve carbon capture in the price range of \$35-40 / tonne CO₂.

BENEFITS

- Lower cost – achieving up to 50% reduction compared to the best amine equivalent due to major improvements in both CAPEX and OPEX expenditure
- Lower energy usage - performing up to 15% less than the best amine technology principally due to reboiler energy requirements typically under 2.5 GJ/tonne CO₂
- Oxygen, SOx and NOx tolerant process - allowing diverse application portfolio including difficult to abate sectors such as cement, steel and waste-to-energy
- Low cost, safe solvent with pre-existing supply capacity – with current potassium carbonate market orders of magnitude larger than forecast CO₂ capture demand requirements
- Small plant footprint - achieved through higher solvent loadings that lead to a process size reduction and patented concentric column design for larger operations.
- No toxic by-products and low solvent volatility – eliminating need for toxic waste disposal, complex wash stages and solvent reclamation units
- Superior environmental performance – particularly benefitting from environmentally benign solvent, lack of toxic by-products and low solvent volatility
- Low impact retrofit integration – design options to provide minimal upstream process impact, or alternatively to maximize heat integration with existing systems to optimize process synergies
- Option to time shift energy demands – The increased loading capacity and solvent price point makes large scale solvent storage for time shifted regeneration economically viable in many situation

DESCRIPTION

The UNO MK 3 process consists of a catalytically enhanced precipitating potassium carbonate solvent technology engineered to capture 90+ per cent of carbon dioxide (CO₂) emissions from heavy industry sources such as cement plants, power stations (pre- and post-combustion) and other large CO₂ emitting industries. Following the invention of the UNO MK 3 process within the Cooperative Research Centre for Greenhouse Gas Technologies (CO₂CRC), the technology has subsequently been developed over the last decade by KC8 Capture Technologies in conjunction with the University of Melbourne in Australia.

Potassium carbonate (K_2CO_3) has been used in solvent absorption processes in chemical industries for many years (i.e. the Benfield process). The patented UNO MK 3 process provides a unique update to this established technology, making it highly efficient for CO₂ capture at low pressure. The UNO MK 3 process contains the absorption and regeneration stages of a standard solvent absorption process. However, unlike a standard liquid-based solvent system, a KHCO₃ precipitate is allowed to form. Removing this constraint allows UNO MK 3 to be operated with concentrated solvent and greater solvent loadings. That, in turn, allows for greater working capacities, lower circulation rates and drives down energy requirements.

To handle solid precipitation in the process, KC8 Capture has conducted extensive R&D to identify and adapt existing process units to meet the challenging requirements. Central to this has been our patented refinement of Turbulent Bed Contactor technology to not only facilitate suitable solids tolerance in the absorber unit, but also provide process intensification, resulting in reduced column height relative to conventional amine processes.

A key benefit of potassium carbonate-based solvents is the significantly lower volatility compared with amine-based solvents. The volatile emissions from amine-based solvents can be significant and usually requires an additional water wash sections as well as continuous solvent make-up. In contrast, the UNO MK 3 process neither requires a water wash stage, nor complex reclamation sections to achieve economic viability.

The UNO MK 3 process is capable of handling a wide range of applications, including both pre- and post-combustion electricity generation and other industrial CO₂ emitting processes. It is unaffected by the impurities in a range of fuel source including black coal, brown coal, natural gas and emissions from cement, iron and steel and other heavy industries. Due to its oxygen tolerance and low volatility, it is also highly applicable in capture from natural gas turbines in either open or closed cycle flue gases. It also has the capacity to be applied either as a new build or retrofit application.

Looking ahead, KC8 has created a range of configurations in relation to large scale single stream contacting systems. This includes a novel patented concentric single stream absorption and stripping combined column, which uses concrete and/or geopolymers as the material of construction. This enables larger column diameters and improves CAPEX performance comparative to conventional steel arrangements. Applications in a single train are now possible for large emission sources.

Pilot plant testing of UNO MK 3 has been completed under real flue gas conditions at Hazelwood Power Station in the Latrobe Valley, Australia, and we are currently in the process of implementing two demonstration facilities of the UNO MK 3 technology.

The first of these is a 10 - 15 tpd CO₂ PACER demonstration facility being built in partnership with Cement Australia, with the plant processing clinker flue gas from a pre-existing industrial plant. Operations will be located at a Cement Australia facility in Gladstone, Australia, and are forecast to begin operations in Q1 2024.

The second demonstration plant has been facilitated by our success in the recent US DoE FleCCS project. During the first stage of this project, KC8 Capture demonstrated that the UNO MK3 in conjunction with pre-existing NGCC and/or OCGT turbines can, based on independent economic analysis, be widely and profitably deployed in future near-zero emission grids. Stage 2 involves a physical demonstration of the technology, which will be on a similar 5 - 10 tpd scale to the PACER project but will focus on the lower CO₂ concentrations found in gas turbine flue gas. This plant will be installed at the NCCC test centre in Alabama, USA, with operations forecast to begin Q3 2024.

These two projects will take KC8 Capture through to a TRL of 7-8, at which point we will be ready to commence construction of commercial scale facilities. Current estimates are that typical applications at full scale will be able to achieve CO₂ capture costs of \$35-40 /tonne.

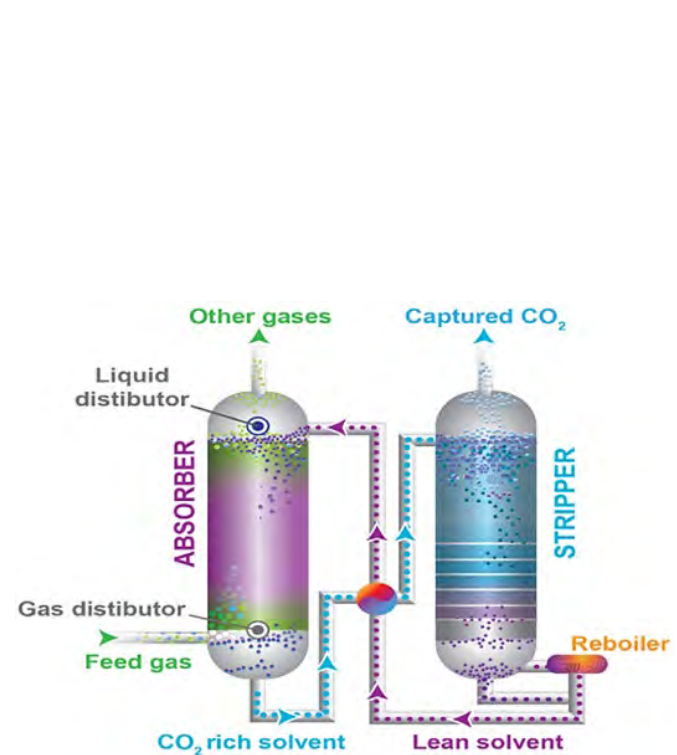

Figure 1: Conventional dual absorption / stripping column configuration

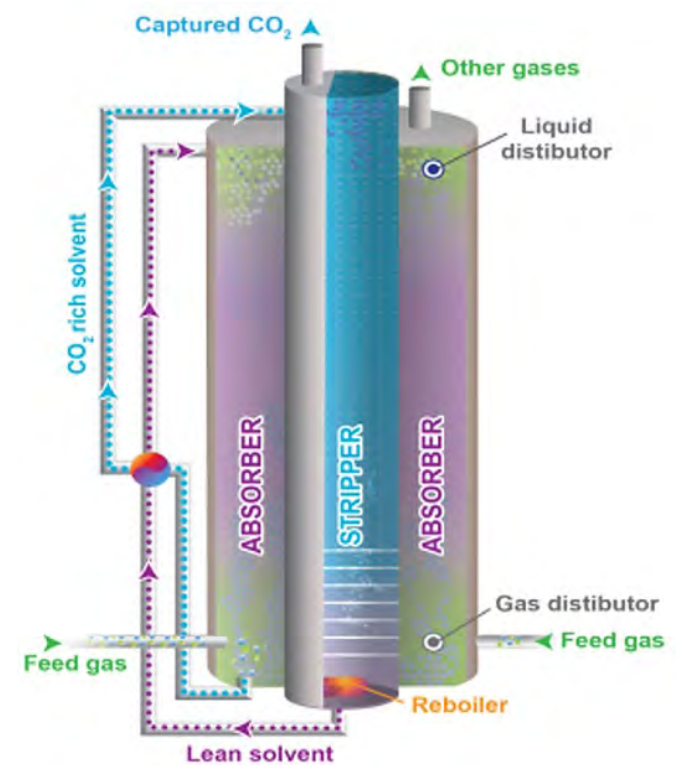
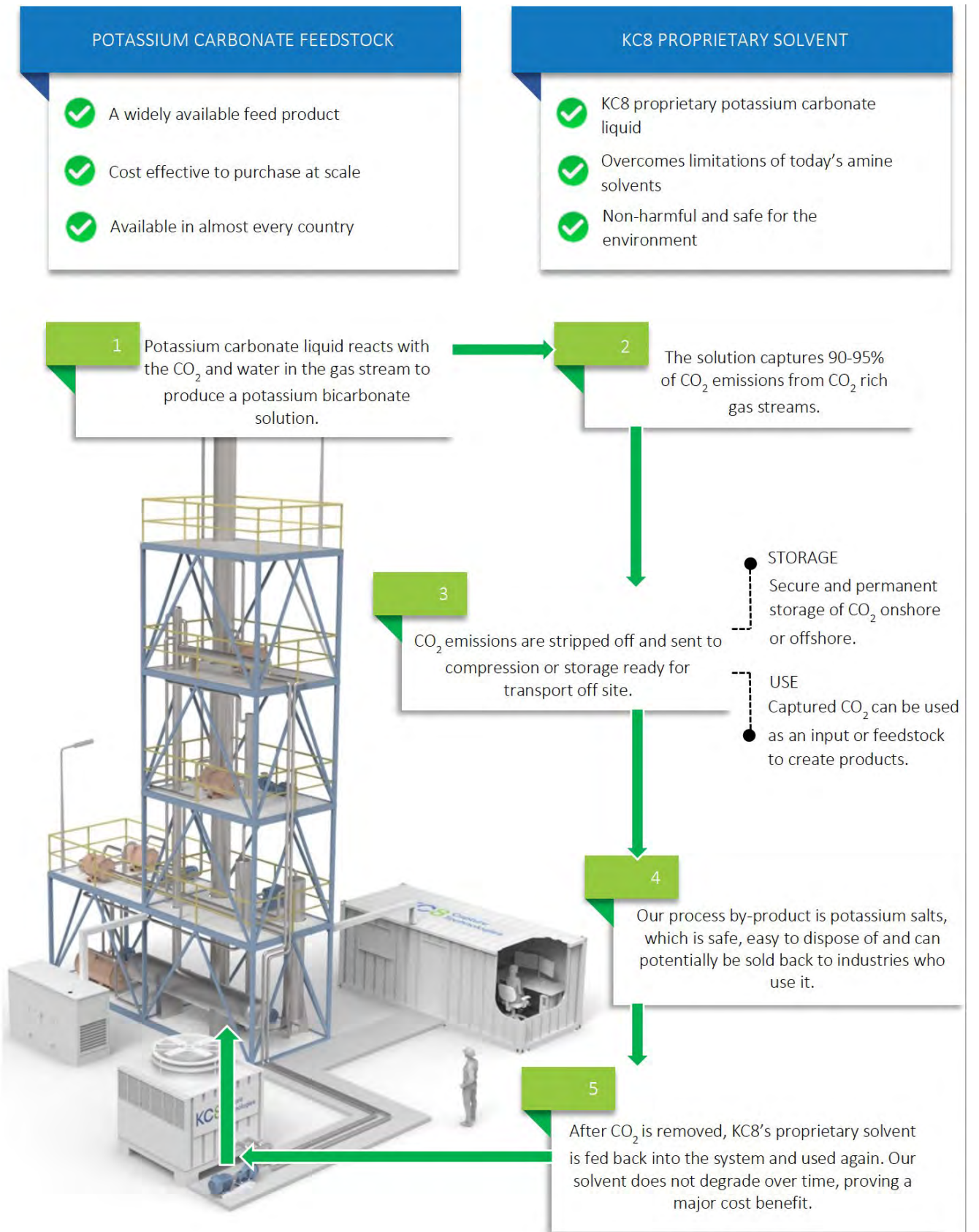

Figure 2: KC8 patented concentric absorption / stripping column configuration

HOW OUR TECHNOLOGY WORKS





CONTACT
 Email: ccus@linde.com
 Web: www.engineering.linde.com/CO2



CARBON MANAGEMENT AS A SERVICE LINDE

SUMMARY

As efforts to reduce greenhouse gases, such as carbon dioxide (CO₂), intensify, finding a reliable supplier who can navigate the complexity of large-scale, multi-year projects is essential for industries such as oil & gas, chemicals, steel, cement, and power generation. Linde has extensive, proven expertise in the treatment of CO₂ along its entire value chain, including its separation, purification, compression, and liquefaction. Furthermore, the company helps its customers explore all their options to store or

potentially reuse captured carbon in other processes. Linde also covers carbon sequestration and collaborates with other companies around the globe.

Projects for managing carbon are performed in the framework of an EPC (engineering, procurement, construction) or as a BOO (build, own, operate). At the same time, Linde invests in own plants and aims to minimize CO₂ emissions in its own production and operations.

BENEFITS

Linde's offering relating to CCUS:

- Economical and technical feasibility studies
- CO₂ capture as a service (build, own, operate)
- Full engineering, procurement, construction (EPC) solution
- EPC services
- Training of operational and maintenance personnel

DESCRIPTION

CCUS is a critical component of a circular carbon economy. Linde is a forerunner in this area with a portfolio of products and solutions that helps its customers fulfill their net-zero emission targets. Here are a few examples:

- Heidelberg Materials and Linde have established a joint venture to build and operate a state-of-the-art carbon dioxide capture and liquefaction plant at Heidelberg Materials' Lengfurt, Germany, plant. CO₂ will be separated directly from part of the exhaust gas stream from the cement clinker kiln using an amine scrubbing system specially developed for flue gases. Linde will also supply equipment for purification and liquefaction, tanks for intermediate storage of the product, and loading facilities.
- Groundbreaking recently took place for a major carbon capture pilot project: the 10-megawatt project at City Water, Light and Power (CWLP) in Springfield, Illinois. The Linde/BASF Advanced Post-Combustion CO₂ Capture Technology used in this project is a major step in demonstrating how capture technologies can be successfully integrated into industrial facilities to reduce CO₂ emissions.
- Linde has signed a long-term agreement with ExxonMobil for the off-take of carbon dioxide associated with Linde's new clean hydrogen

production in Beaumont, Texas. Under the terms of the agreement, ExxonMobil will transport and permanently store up to 2.2 million metric tons of carbon dioxide each year from Linde's hydrogen production facility, equivalent to the emissions from nearly half a million cars per year.

- Linde's engagement in CCUS extends to fostering innovation. To this end, Linde has opened its first R&D center for CCUS technologies in Saudi Arabia's Dhahran Techno Valley. Aside from developing solutions, the center will offer training and education for professionals, customers, and universities.

TECHNOLOGIES FOR A LARGE VARIETY OF CARBON INTENSITIES AND SOURCES

The projects and innovative activities described above rely on our extensive portfolio of technologies and services along the whole CO₂ value chain. When deciding which solution to select, the company's engineers first verify which CO₂ concentrations need to be addressed – low, medium, or high (Figure 1). Linde provides solutions for many different CO₂ emitting industries. The technologies are further divided into their suitability for the CO₂ source, whether it be flue gas, natural gas, syngas, or tail gas.

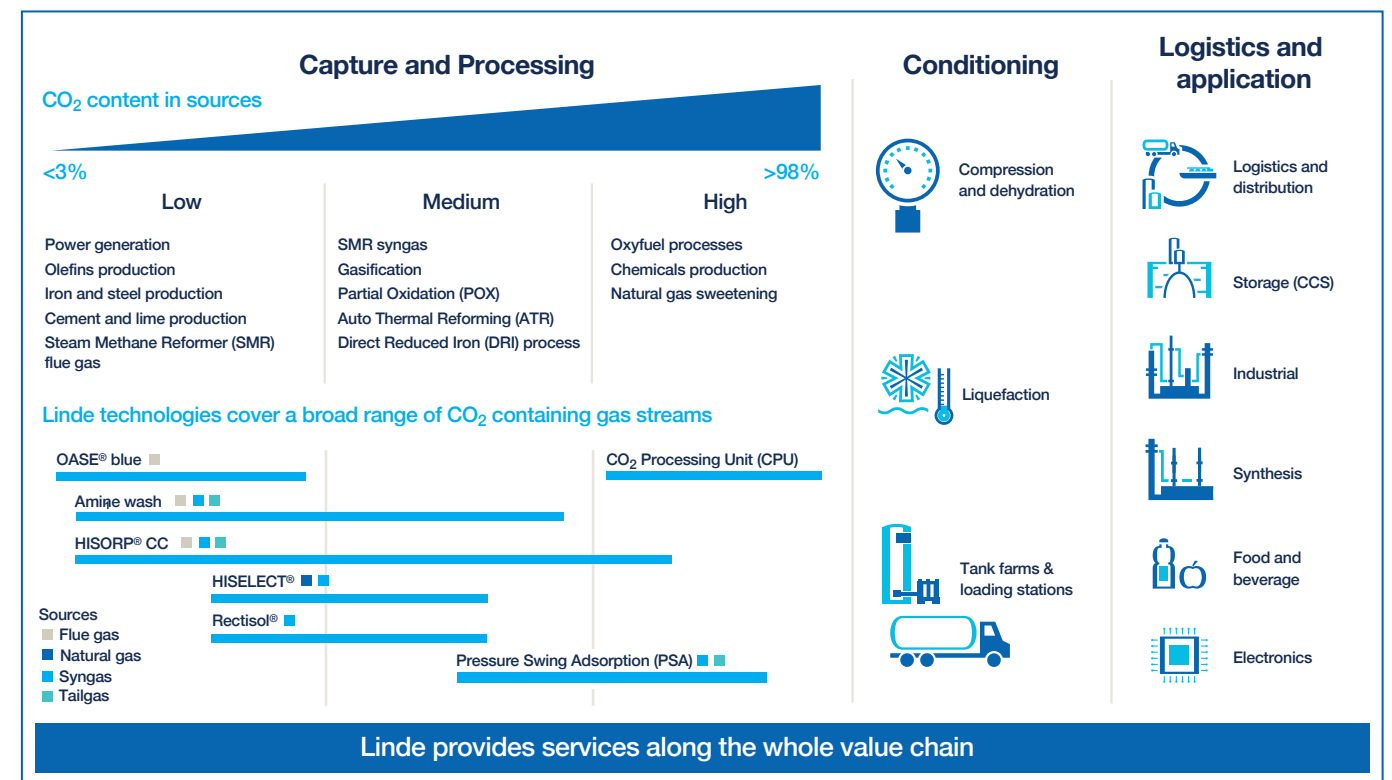

Figure 1: Overview of Linde's technology portfolio along the CO₂ value chain.

¹ OASE® is a registered trademark of BASF SE



FOR GAS STREAMS WITH LOW CO₂ CONTENT

OASE® blue technology for Post-Combustion CO₂ Capture (PCC)

Post Combustion CO₂ Capture (PCC) is a mature option to capture CO₂ from flue gas streams and thus ensure compliance with increasingly strict emissions thresholds. With the OASE® blue technology, CO₂ is removed from the flue gas through chemical scrubbing with an aqueous amine-based solvent (Figure 2). It can be implemented downstream of existing assets without interfering with upstream processes. For new assets, advanced plant integration concepts and optimized total costs of ownership can be accomplished.

The optimal design of turnkey facilities using OASE® blue technology has been jointly developed by BASF and Linde. It leverages BASF's capabilities in high-performance gas treatment technologies and Linde's strength and proven track record in design and delivery of turnkey industrial plants. This results in an optimal interplay of solvent, process design, equipment, and plant integration.

The technology can be applied to flue gases from various sources, such as different types of power plants, gas motors, steam generators, cement plants, and furnaces, just to name a few. It easily covers a spectrum from 3 to 25 vol% CO₂ content in the flue gas. The technology allows for CO₂ capture rates higher than 95% and generates a CO₂ product purity of 99.9 vol% (dry). This purity is in

compliance with the CO₂ product specification in most cases. Therefore, a further purification step may not be necessary.

This high-performance CO₂ capture technology in combination with our solid track record in large-scale gas treatment plants ensure low risk in EPC projects.

Highlights

- Compact footprint
- High CO₂ capture rate even at low CO₂ concentrations
- 20% lower energy consumption and 20% lower circulation rate compared to MEA solution
- Low solvent degradation rate even at elevated oxygen content in flue gas, and therefore low solvent consumption rate
- Different options for energy and heat integration
- Unique emissions control technology for minimum environmental impact
- > 500 OASE® gas treatment plants in operation for different applications
- > 65,000 hours of operational experience with OASE® blue
- Reference plants in Germany and the United States

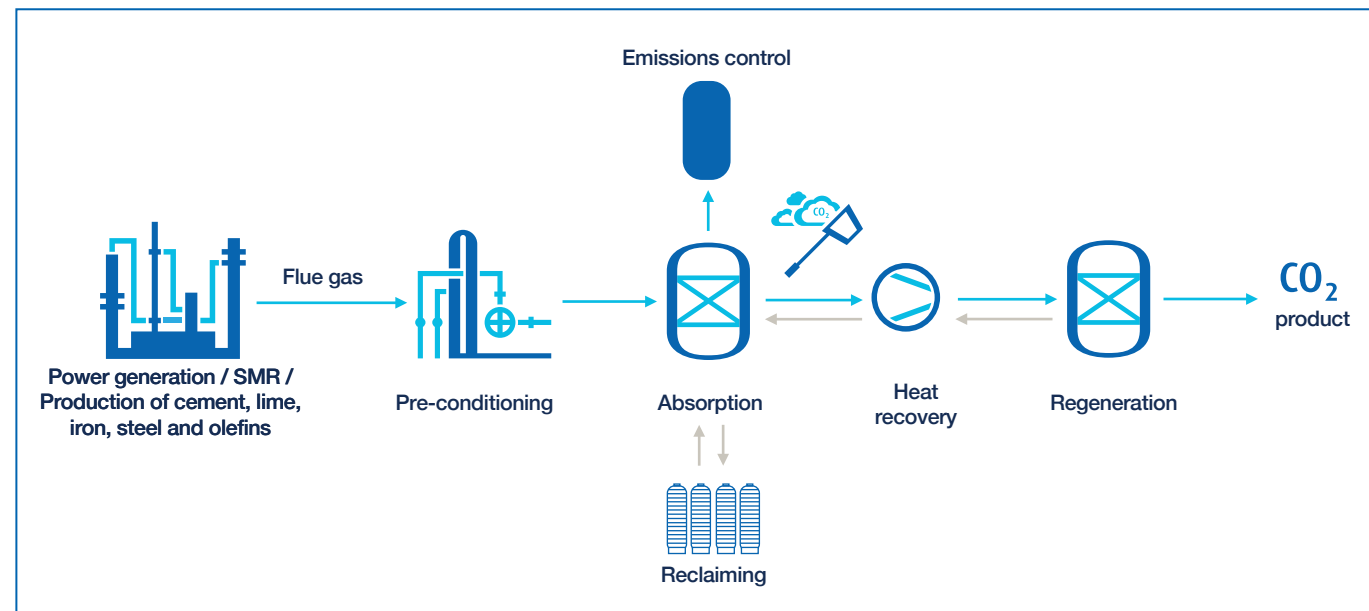

Figure 2: OASE® blue post-combustion CO₂ capture (PCC) process
OASE® is a registered trademark of BASF SE

FOR GAS STREAMS WITH LOW TO MEDIUM CO₂ CONTENT

Amine wash

Amine wash processes are the standard for CO₂ removal from steam methane reforming (SMR)-based hydrogen, syngas, and ammonia plants. CO₂ capture from syngas (Figure 3) is a proven technology, which achieves a CO₂ recovery rate of 99.9%. Further advantages include a low investment and favorable operating costs. Amine wash units can be installed in various areas of a plant, from low- to high-pressure applications. They are also suitable for advanced CO₂ removal as well as simultaneous removal of CO₂ and sulfur. Amine wash units can also be combined with other Linde technologies, such as the Linde Ammonia Concept (LAC™), or with cryogenic processes for carbon monoxide production.

Highlights

- State-of-the-art process
- Compact design
- Favorable design for low-pressure and high-pressure applications
- Compatible for CO₂ removal and/or sulfur removal

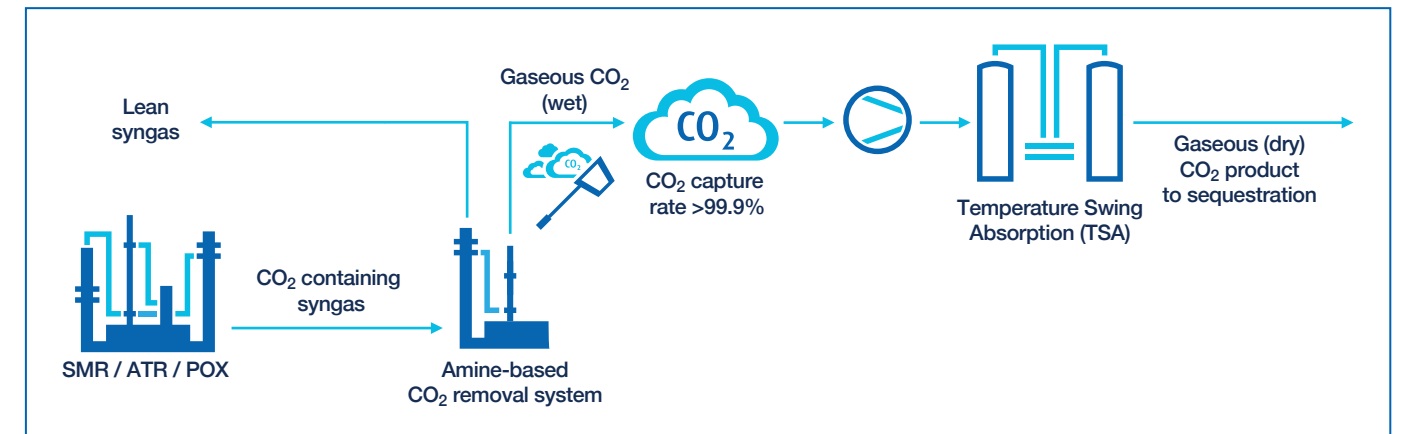

Figure 3: Amine wash-based CO₂ capture process from syngas



HISORP® CC

HISORP® CC is a mature carbon capturing process based on adsorption and cryogenic separation technologies. It follows a toolbox approach for customizing the process setup on a case-to-case basis with the aim to minimize the carbon footprint of CO₂-emitting industries.

HISORP® CC can be applied for pre- and post-combustion carbon capture from various CO₂-emitting sources. One application is for blue hydrogen production plants (both for new builds and retrofits), such as SMR, autothermal reforming (ATR), partial oxidation (POX), and gasification. Here, the toolbox approach shows its advantages by optimally combining separation technologies to minimize carbon intensity and maximize hydrogen production. To produce blue hydrogen, HISORP® CC can be applied in the syngas or the tail gas route of the hydrogen Pressure Swing Adsorption (PSA) of existing SMRs and ATRs.

Especially for newly built ATR and POX reactors, HISORP® CC is used for carbon capture in the tail gas of the H₂ PSA with advantages regarding reliability of H₂ production and specific energy consumption for CO₂ removal. In addition, for existing SMRs, post-combustion CO₂ capture (PCC) from the flue gas is often the preferred approach to minimize carbon intensity. Furthermore, HISORP® CC can be applied for PCC from various other flue gases of hard-to-abate CO₂ sources, e.g., cement and lime production, steel production, and power generation.

HISORP® CC achieves overall CO₂ capture rates of up to 99.7% and is flexible in regard to scale (covering all relevant industrial sizes), CO₂ feed concentration, the state of the CO₂ export product (in gaseous, liquid, or supercritical form), and all purity levels (e.g., industrial grade or high-purity food & beverage grade).

Highlights

- Combines Linde's inhouse adsorptive and cryogenic technologies
- Individual HISORP® CC concepts for different feed streams by using Linde's toolbox
- Flexible in size and scale
- All individual process units within the HISORP® CC process are in operation and have technology readiness level 9
- HISORP® CC can be adapted to various CO₂ product requirements (gaseous/liquid/supercritical CO₂, purity grade for sequestration or utilization)
- Packaged unit design (pre-manufactured & workshop tested) for minimized on site construction effort
- CO₂ capture rate >99%
- No steam required (only electrical power)
- No consumption, handling, makeup, and disposal of chemical washing agents
- No hydrogen losses when applied for CO₂ capture in blue hydrogen production
- Includes smart pre-treatment for trace-impurity removal from flue gases

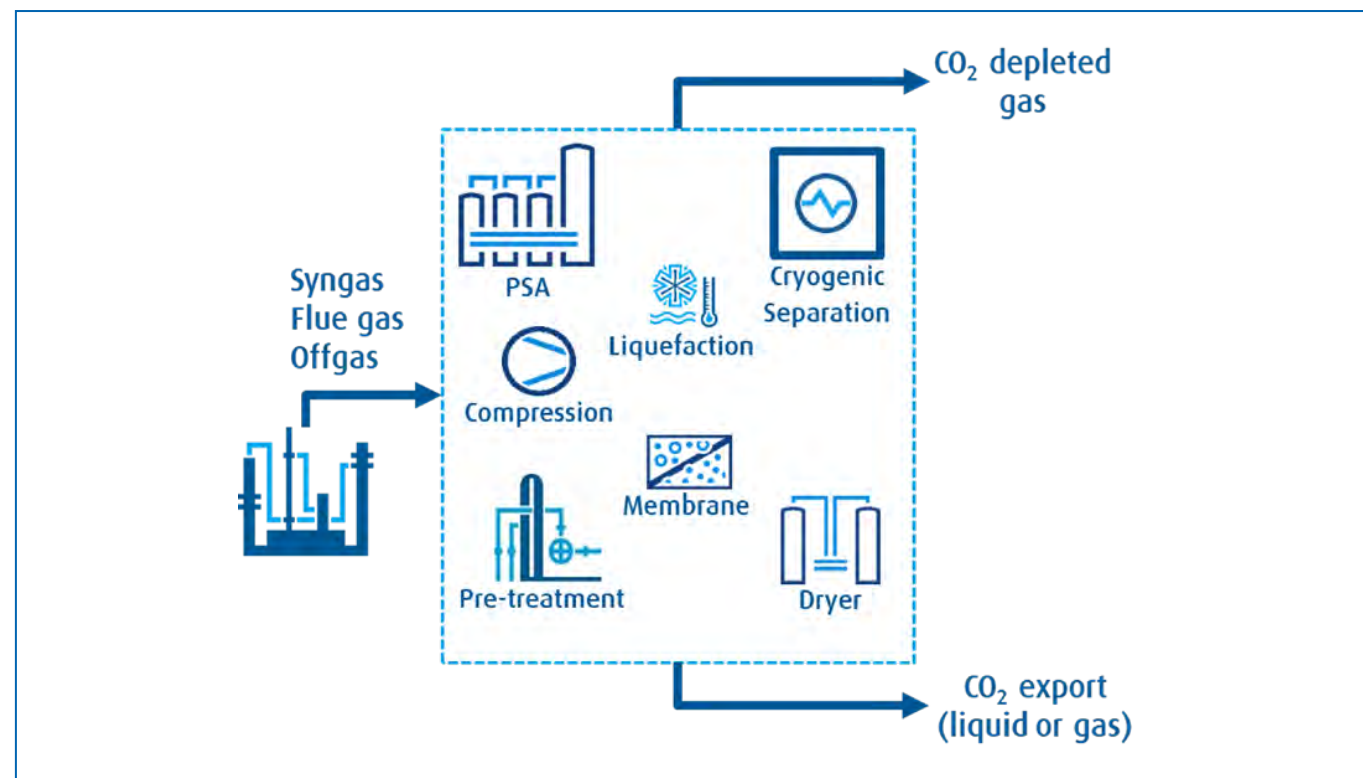

Figure 4: HISORP® CC: Mature toolbox approach to reduce CO₂ emissions from various industries.

HISELECT® powered by Evonik membranes

The HISELECT® membrane was originally developed with a focus on natural gas and process gas industries. For natural gas resources with sour and acid fractions, membranes are an excellent alternative to conventional amine wash systems for acid gas removal. Driven by partial pressure difference, the HISELECT® membrane works like a semi-permeable barrier and separates the feed gas into a low-pressure permeate, rich in the gas to be removed or recovered (such as CO₂), and a high-pressure retentate with a low content of these components. A typical setup of a gas processing unit with membranes is shown in Figure 5. HISELECT® membranes efficiently remove CO₂ from natural gas over a wide flow rate and concentration range. The membranes demonstrate high selectivity for CO₂, irrespective of high hydrogen content (HHC) and CO₂ partial pressure. Additionally, strong resistance to unsaturated hydrocarbons, mechanical robustness, and high resistance to hydrogen sulfide (H₂S) result in low maintenance requirements and a rapid return on investment. Beside applications in natural gas sweetening, HISELECT® membrane technology can also be applied in hybrid solutions with pressure-swing or temperature-swing adsorption units to efficiently remove CO₂ or other gases from process gases.

Highlights

- Low CAPEX and OPEX with high operational flexibility
- High separation capacity and high selectivity for maximum recovery rates and high purities
- Ability to tailor membrane capacity and selectivity to customer requirements
- High volume efficiency due to optimized packing of hollow fiber membranes
- Production flexibility with wide feed stream condition range and supporting temperatures up to 100°C and pressures up to 200 bar
- Resistant to CO₂ partial pressure of up to 50 bar
- Robust and stable performance over time under harsh operating conditions, reducing need for overdesign
- Reduced pre-treatment effort due to excellent resistance to heavy hydrocarbons and plasticization
- Mechanical resistance to process fluctuations during operation

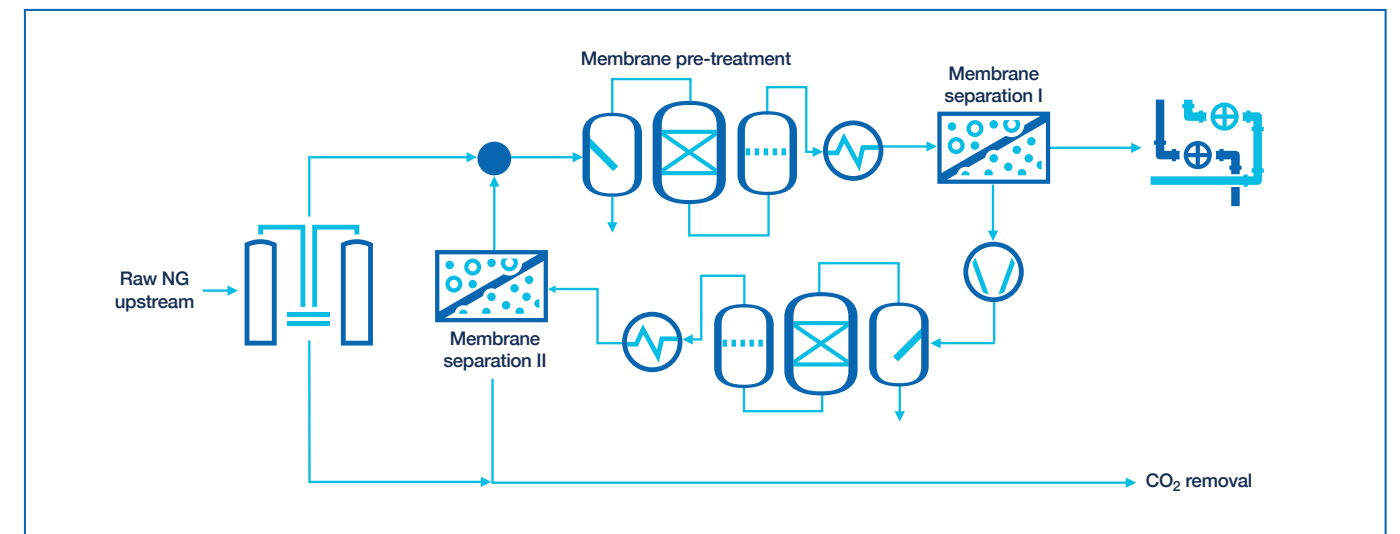

Figure 5: Typical process design of a gas processing unit with HISELECT® for natural gas acid removal

Rectisol® wash unit

Linde's Rectisol® wash unit is able to extract sour gas from syngas. The solution uses proven technology that is adjusted to the actual needs and requirements of plant operators. Its application in syngas is indicated in Figure 6. It is flexible with respect to upstream syngas generation as well as gas specification for downstream applications.

Rectisol® can either be used for selective removal of CO₂ and sulfur, or it can be designed for designated CO₂ capture. In case of selective removal of CO₂ and sulfur, about 99% of the CO₂ can be captured sulfur-free, which means that no additional desulfurization units are required. Rectisol® can be integrated with other Linde gas processing technologies (such as downstream PSA and cryogenic processes). Nominal capacities can vary widely, from small-scale plants (30,000 Nm³/h feed gas) up to high one-train capacity plants (2,000,000 Nm³/h feed gas).

Highlights

- State-of-the-art process
- Used for the treatment of feed gas containing sulfur and CO₂
- Water- and sulfur-free CO₂ product for further processing
- Enriched H₂S fraction can be realized within one process
- Easy solvent handling (chemically stable, low cost, and readily available on the market)
- Enhanced trace component handling
- Low product losses (H₂ and CO)

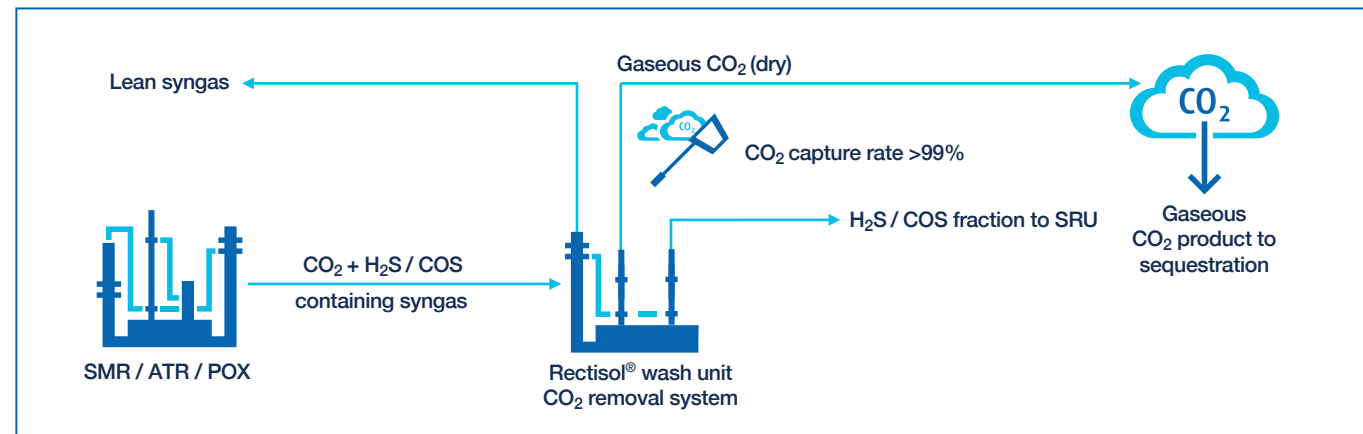

Figure 6: Typical Rectisol® process design for CO₂ capture from syngas

FOR GAS STREAMS WITH MEDIUM TO HIGH CO₂ CONTENT

CO₂ PSA

Linde's pressure swing adsorption (PSA) system is an innovative, efficient, and low CAPEX technology for the recovery of CO₂ from process gas streams covering a wide concentration range, such as from process gases including syngas streams and iron and steel production off-gases, as shown in Figure 7.

In the case of syngas, PSA technology is used to recover CO₂ from upstream, high-pressure raw syngas streams or low-pressure off-gas streams generated by SMR or gasification processes. In many cases, PSA technology is a more cost-effective alternative to conventional washing systems due to its lower investment and operating costs.

In the iron and steel industry, PSA technology can be used to efficiently remove CO₂ in direct reduction or blast furnace off-gases. The process removes maximum amounts of CO₂ yet leaves valuable gas components, such as H₂, CO, and CH₄, in the gas stream for further processing.

A CO₂ PSA unit can achieve a product purity of up to 95 vol%, with unit capacities ranging from a few thousand Nm³/h to around 300,000 Nm³/h.

Highlights

- Mature and robust purification technology
- No electricity consumption
- No steam required for regeneration (thereby no additional CO₂ generation)
- No solvent is applied
- No negative environmental impact due to the emissions of solvent traces in exhausts or CO₂ product
- No extra cost for solvent makeup and handling
- Low CAPEX and OPEX

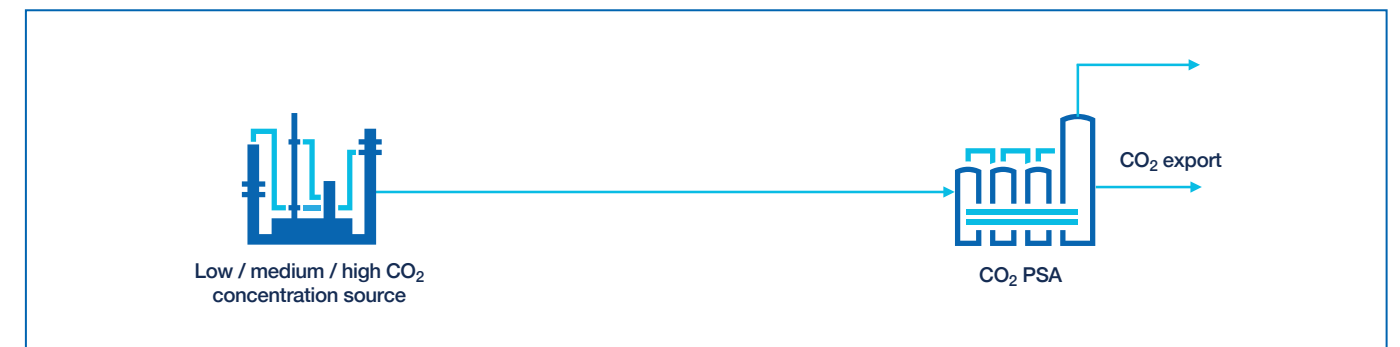

Figure 7: Typical CO₂ PSA process design for efficient capture of CO₂ from process gases

CO₂ PROCESSING UNIT

Linde's CO₂ Processing Unit (CPU) is applied to purify CO₂-containing gas streams to provide typical CO₂ product specifications for a variety of industrial applications. Typical CPU feed gas streams are CO₂-rich gases generated from CO₂ capture processes, flue gases from oxy-fuel combustion processes, and CO₂-rich off-gases from chemical plants, such as ammonia, ethylene oxide, methanol, or ethanol plants. As shown in Figure 8, an extended toolbox of processes and technologies allows for the removal of different trace components, such as sulfur- or nitrogen-containing compounds, hydrocarbons, heavy metals, and air gases.

Linde initially developed and commercialized the CPU technology to treat oxy-fuel flue gases at an oxy-fuel lignite-fired power plant at Schwarze Pumpe, Germany. More recently, Linde's CPU has been considered for oxy-fuel projects in the cement industry. Mature CO₂ processing technologies in combination with Linde's track record in large-scale gas-treatment plants ensure low-risk EPC projects for clients.

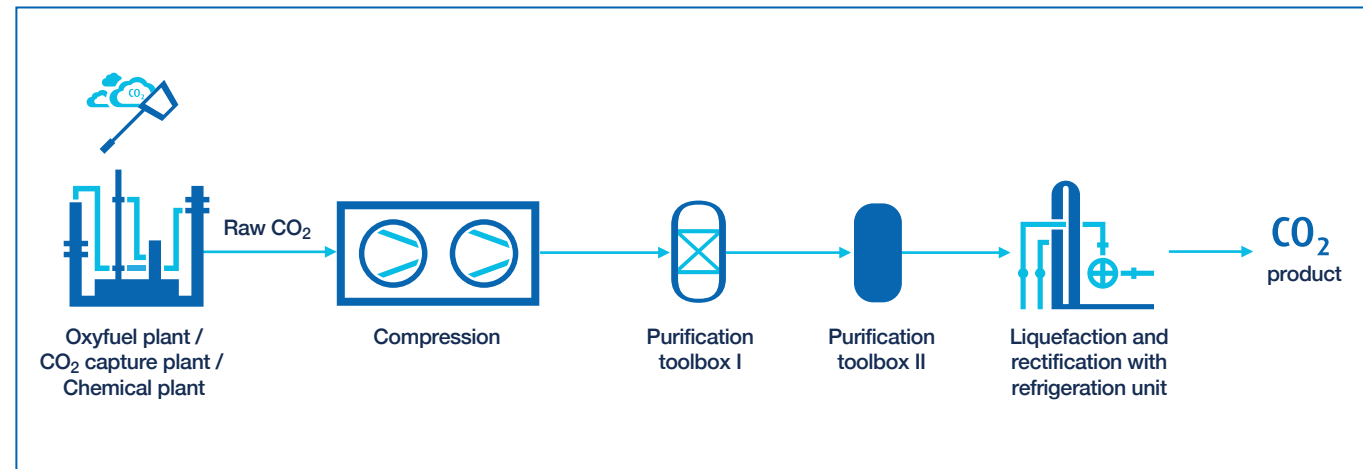

Figure 8: Typical CO₂ Processing Unit (CPU) design

Highlights

- Mature and robust purification technology
- Reference plant in Schwarze Pumpe, Germany, for treatment of oxy-fuel flue gases
- Multiple EPC and Linde operation references for production of food-, chemical-, and electronics-grade CO₂
- Standardized and skid-mounted modules as well as large-scale customized, stick-built solutions available

CO₂ COMPRESSION/DEHYDRATION

CO₂ compression and dehydration (see Figure 9) are the most common process units in all CO₂ plants. If the CO₂ purity already meets specification requirements after the CO₂ capture process, the downstream CO₂ treatment usually involves compression and dehydration. It is also a typical process unit for CPU and CO₂ liquefaction plants.

Depending on the plant capacity, different types of compressors can be used, such as piston, screw, and turbo compressors. And depending on local costs for utilities, electrical or steam-driven compressors can be employed.

The targeted CO₂ product pressure is defined by the downstream application or distribution concept. Pressures of up to a maximum of 215 bar have been realized.

Compressor stations not only compress the main CO₂ feed gas stream, but can also be used to integrate and compress boil-off gases from storage tanks and other CO₂-rich vents from the plant.

Highlights

- Mature and robust technology
- Various options for compressor type
- Multiple references for different scales worldwide

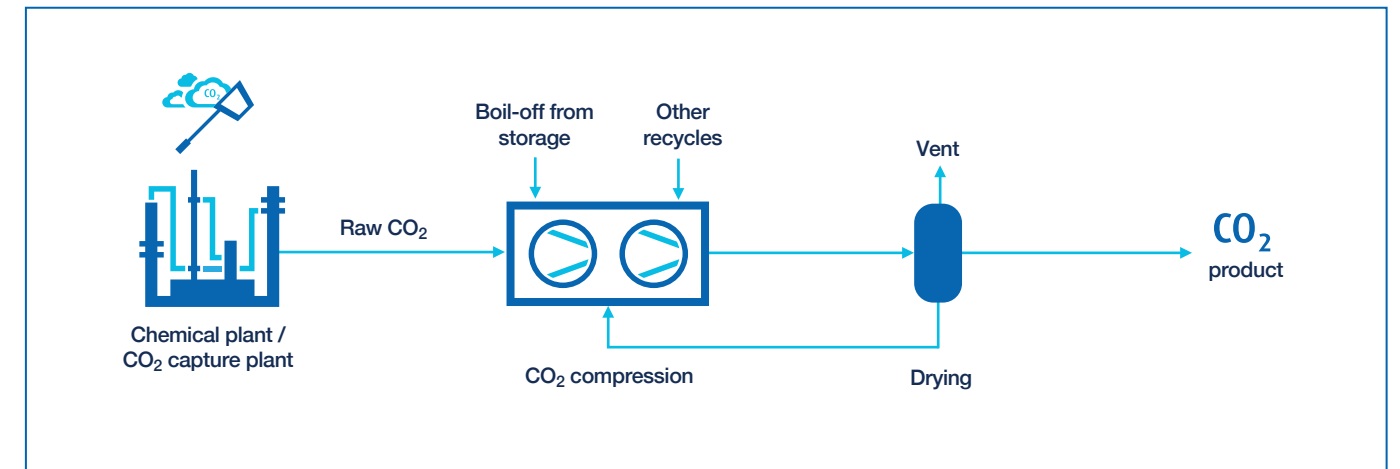

Figure 9: Typical CO₂ compression and drying process design



CO₂ LIQUEFACTION

CO₂ liquefaction, as shown in Figure 10, can be an additional process step attached to a CO₂ capture and processing plant. For example, when CO₂ is purified by means of cryogenic separation (rectification), CO₂ liquefaction is involved. In addition, CO₂ liquefaction might be required because of the CO₂ logistics concept when transporting it via road trailers, trains, or ships.

Linde's largest liquefaction plant, in operation since 2015, is producing approximately 1,350 tons of CO₂ per day. The CO₂ is used in enhanced methanol and urea production.

Additional large-scale plant references can be found in Norway and the United States for carbon capture and storage (CCS) and food applications, respectively. Depending on local needs, the integration concept, safety considerations, and cost efficiency, different refrigerants can be considered for use in the refrigeration unit.

Highlights

- Mature and robust technology
- Various options for refrigerants available
- Extended reference list at various product capacities
- Standardized and skid-mounted modules as well as large-scale customized, stick-built solutions available

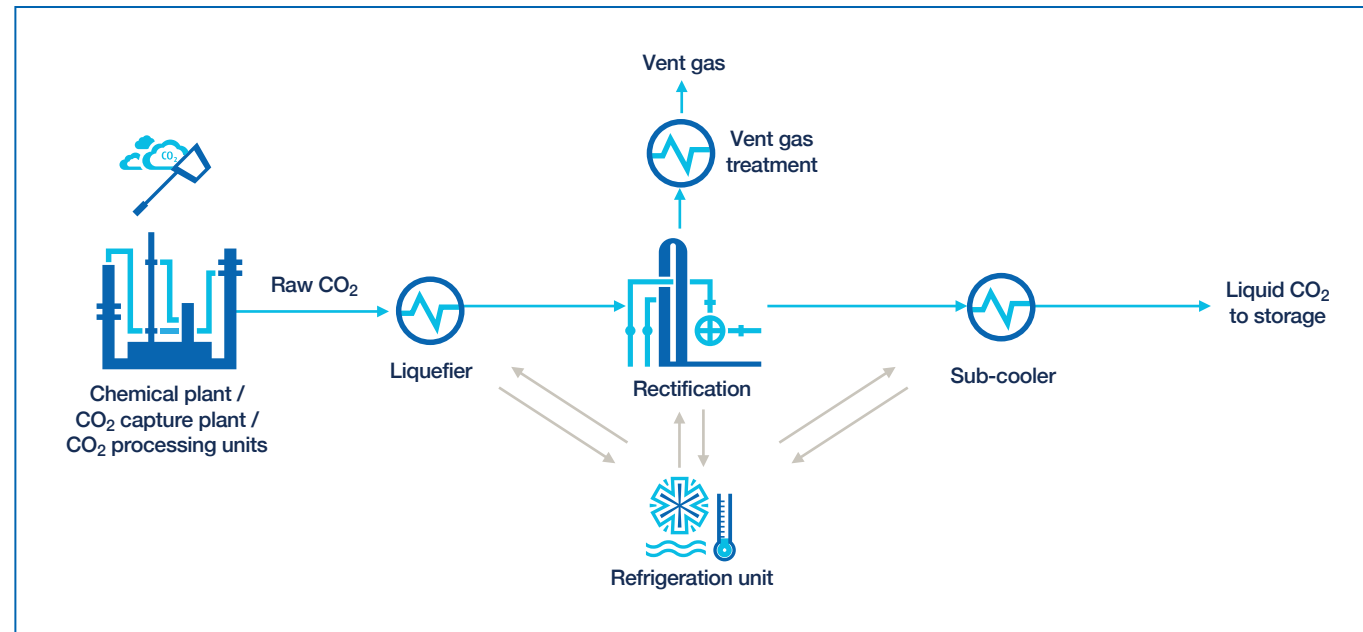

Figure 10: Typical CO₂ liquefaction process design

CO₂ TANK FARM AND LOADING STATIONS

Linde offers state-of-the-art tank farms to store liquid CO₂. A range of configurations are available. For example, the storage tanks can be spherical or cylindrical (vertical or horizontal). Tank farms can be equipped with boil-off gas re-liquefaction as well as integration of gas return lines. Moreover, an essential component of a tank farm is a loading station. While most tank farms feature trailer loading stations, Linde has also built train and ship loading stations (see Figure 11). This covers the whole range of potential distribution concepts.

Highlights

- Extended reference list at various product capacities
- High degree of standardization and skidded packages to reduce CAPEX

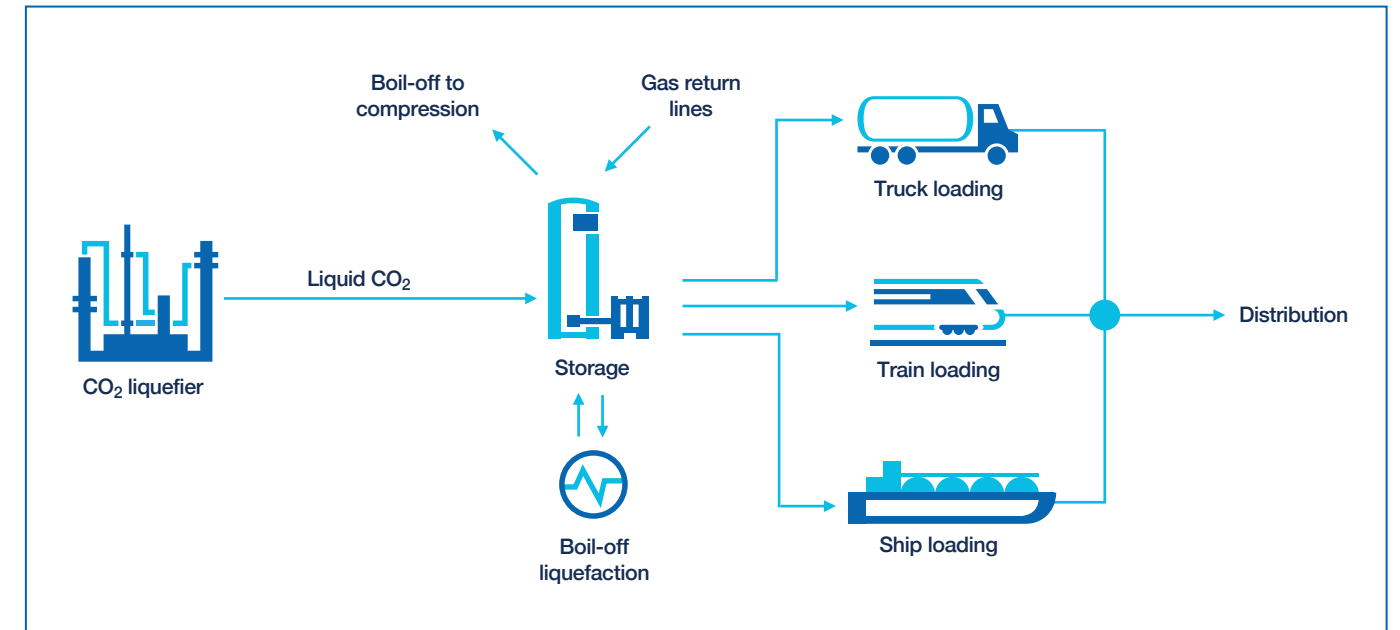

Figure 11: CO₂ tank farm and loading station





“THE ENERGY TRIFECTA” - CLEAN, RELIABLE, & LOW-COST ENERGY FROM NATURAL GAS. NET POWER

SUMMARY

NET Power delivers the “energy trifecta” – clean, reliable, and affordable energy from natural gas.

NET Power combines a semi-closed loop cycle that inherently captures CO₂ and produces power. The company combines oxy-combustion and a supercritical CO₂ (sCO₂) power cycle to deliver on-demand natural gas power while capturing nearly all emissions. The CO₂ from oxy-combustion is recirculated back to the combustor and a portion is exported for utilization or sequestration.

NET Power’s recent momentum is built upon more than a decade of milestones, including key investments, construction and testing at a 50 MWth demonstration facility in La Porte, Texas, a slate of strategic engagements, and the announcement of its first commercial facility in West Texas. In February 2022, NET Power formed a Joint Development Agreement with Baker Hughes to advance the design of key turbomachinery and equipment used in the NET Power Cycle. In June 2023, NET Power completed its business combination with RICE Acquisition Corp II (NYSE:RONI), making Net Power a publicly traded company (NYSE:NPWR).

BENEFITS

The utility-scale NET Power system is being designed to achieve the following benefits:

- **Clean:** Average Carbon Intensity (CI) of 58g CO₂e/kWh and can capture CO₂ at rates >97%, providing for 87% CO₂ emissions reduction in comparison to conventional Combined Cycle Gas Turbine (CCGT) technology. No risk of NO_x, SO_x, or particulate emissions.
- **Reliable:** Provides 24/7 dispatchable, baseload power with a targeted capacity factor of 92.5%, power ramp rates of 10% to 15% per minute, and 0% to 100% load following capabilities while capturing all emissions.
- **Low-Cost:** Initial NET Power plants target a levelized cost of energy between \$26-\$55 \$/MWh.
- **Utilizes Existing Infrastructure:** NET Power plants can leverage existing pipeline and electricity transmission networks for planning and operations.

- **Compact Footprint:** Less than 50% footprint of a similarly sized CCGT facility with post-combustion capture; further enables use of brownfields sites.
- **Value of Carbon:** The NET Power Cycle inherently captures high-purity, pressurized CO₂ for sequestration or utilization in Enhanced Oil Recovery, eFuels, synthetic chemicals, and product integration.

DESCRIPTION

SECTION 1: TECHNOLOGY DEVELOPMENT

NET Power has developed and optimized its technology during more than a decade of research, development, and operational demonstration. From the very beginning, the NET Power Cycle was designed to overcome the challenges faced by both conventional and renewable energy technologies pursuing grid-scale decarbonization. It solves the energy “trilemma” by providing clean, affordable, and dispatchable power. By meeting these three criteria, NET Power is able to integrate into existing grid infrastructure and markets while delivering additional benefits, such as capturing nearly all carbon emissions.

NET Power achieves this through its unique combination of oxy-combustion of natural gas with a supercritical CO₂ power cycle. In the process, natural gas is burned using a mixture of oxygen and CO₂. The combustion produces CO₂ and water, which are added to the CO₂ process stream at high pressure. The high-pressure fluid flows through a turboexpander, which produces power and condenses water from the process fluid while capturing the CO₂. Most CO₂ returns to the process through compression and pumping, while a stream of continuously captured CO₂ is removed from the process at high purity and pressure suitable for permanent storage or utilization. The result: carbon emissions are contained during the process, so there's no need for costly post-combustion capture.

In more detail, The NET Power Cycle can be broken into seven steps:

1. **Air Separation:** The NET Power Cycle begins by purifying and compressing atmospheric air into the separation systems. An insulated, specially engineered

“cold box” then separates the air into its component gas molecules (including oxygen, argon, and nitrogen).

2. **Oxy-Combustion:** The oxygen filtered out in the air separation unit (ASU) is combusted with natural gas and recuperated supercritical carbon dioxide in a series of parallel, direct-fired combustors feeding the turbine-generator. The natural gas is burned in 99.5% pure oxygen and CO₂ resulting in a stream of predominantly steam and CO₂.
3. **Turboexpander:** The combustion process creates a high-pressure CO₂ working fluid that expands and turns the turboexpander to generate electricity.
4. **Heat Exchanger:** The turboexpander reduces the pressure of the CO₂, which exhausts to a series of recuperative heat exchangers to cool.
5. **Water Separator:** The byproducts of the oxy-combustion process are water and CO₂. As the working fluid cools, it is routed through a condensed water circulation loop that condenses the water vapor and separates the low-pressure, high purity CO₂.
6. **Compressor:** Some of the high purity CO₂ is removed and exported via pipeline for sequestration or utilization, and the remaining CO₂ is re-compressed in adiabatic and isothermal processes, where process heat and mass are recycled.
7. **Recirculation:** Recycled CO₂ is reheated and recirculated to be mixed with natural gas and oxygen in the combustor, starting the cycle again.



Figure 1: The NET Power Process

NET Power is developing a 300 MW Class utility-scale power plant producing clean, dispatchable energy alongside 850 Mtpa of high-pressure, high-purity CO₂ and 500 gallons of water per minute at a target net efficiency approaching 50% for the first generation of plants. Electricity output is designed to be ramped at a rate of 10%-15% per minute with full carbon capture across the operating spectrum. Meanwhile, criteria pollutants are avoided and CO₂ emissions are captured as an inherent feature of the cycle.

This performance is possible by using pure oxygen instead of air in the combustion process; the byproducts of combustion are primarily water and CO₂. Rather than intaking new air with each cycle and releasing emissions into the atmosphere like a traditional gas turbine, the cycle extracts the remaining heat from the exhausted working fluid and reintroduces a substantial portion of CO₂ back into the turboexpander after removing the water. The semi-closed-loop cycle recirculates the vast majority of the combustion-derived CO₂ as the working fluid used for power generation in the turboexpander. In this way, CO₂ is inherently captured at high pressure as a fundamental feature of the cycle and not as an add-on process.

The use of sCO₂ as the working fluid offers two main advantages. First, CO₂ has a higher specific heat than other gases (e.g., air) due to its high molecular weight. Second, supercritical CO₂ has the density and compressibility of a liquid while having gas-like viscosity. These physical properties enable NET Power facilities to use smaller equipment when compared to similarly rated conventional power plants. Its high-pressure operation also allows for significant power production at the turboexpander. In addition, the high density of a CO₂ working fluid allows pumping to replace centrifugal compression for

pressurization, which further enhances cycle efficiency. Smaller equipment requires a smaller footprint (3.24 to 5.38 ha for NET Power plant) and, therefore, land use for the plant is approximately 40 to 50% less in comparison to similar output gas-fired power plants (7.5 to 11 ha for combined cycle gas turbine).

SECTION 2: DEMONSTRATION FACILITY

In order to demonstrate the NET Power Cycle at scale, the company designed and built a test facility in La Porte, Texas. The facility, commissioned in 2018, covers five acres and has over 1,500 operational hours as of October 2022.

During testing, the test cycle underwent start-up, shutdown, and transient/excursion tests at key operating points. This included building CO₂ inventory, shedding CO₂ inventory, verification of process chemistry, validation of control and safety systems, operations of pumps and compressors, and testing of process stability and controllability. In late 2021, the facility achieved synchronization with the Texas ERCOT grid.

During this testing, the facility completed multiple 24-hour test campaigns while further validating stop/start sequences, steady state operation, and ramping operations, allowing for the refining of the plant control system. The facility has also successfully exceeded numerous utility-scale plant specifications, including turboexpander inlet temperature and balance of plant operating pressures. In addition to achieving these milestones in technical validation, the plant informs the design of NET Power's commercial product - the utility-scale 300 MW Class plant. The NET Power test facility also



Figure 2: NET Power's La Porte Demonstration Facility

drives further development of key intellectual property and procedures, as well as enabling hands-on training for future NET Power technical, operations, and maintenance personnel.

SECTION 3: JOINT DEVELOPMENT AGREEMENT (JDA)

NET Power formed a strategic partnership with Baker Hughes in February 2022 through a Joint Development Agreement (JDA) supporting the technical and commercial deployment of NET Power's technology. As part of the agreement, Baker Hughes has invested cash equity into NET Power and is partnering in the global development and commercialization of NET Power technology.

As part of this technical development program, Baker Hughes is leveraging its advanced technology capabilities to develop supercritical CO₂ turboexpanders and other critical pumping and compression technology for NET Power facilities. Baker Hughes also brings a deep experience in systems integration and process knowledge, which will help benefit NET Power's design and deployment. The structure of the JDA facilitates the sharing of best practices and lessons learned, while also aligning commercial efforts globally through joint marketing of the technology.

The JDA program has entered its development stage in 2023. Testing on the first industrial-scale combustor and turboexpander will begin in 2025 at La Porte in preparation for the first utility-scale deployment and commercial operation of a full-scale NET Power facility.

SECTION 4: NEXT STEPS

In November 2022, NET Power announced that its first utility-scale plant will be built in West Texas. The new plant will capture CO₂ at unit-wide rates above 97% and utilize both currently operating CO₂ transport and subsurface infrastructure to store captured CO₂. The project will be supported by a strategic consortium of partners consisting of leading developers, power plant operators, CO₂ transportation & storage experts, offtake specialists, and technology providers. Additionally, NET Power intends to leverage existing tax incentives, such as 45Q, and DOE funding opportunities like grants and loans, to support and further de-risk the first project. The successful deployment of NET Power's first utility-scale plant will pave the way for other commercial projects already in development.

NET Power is currently engaged in discussions globally with companies and governments pursuing clean, reliable, and low-cost power. Many global markets present incredible opportunities, and NET Power is actively identifying these bright spots to ensure decision-makers are aware of the technology's immediate potential.

Several use cases present immediate hub opportunities. Pairing NET Power with Direct Air Capture (DAC) is one exciting application. DAC deployments require significant amounts of reliable, low-cost, emissions-free power to maximize their negative emissions impact and economics. DAC facilities require clean, baseload power generation and are unable to quickly ramp in response to variable renewable energy (VRE) production. Alternatively, DAC projects are forced to rely on grid backup, storage, or grid power itself to operate at high capacity factors, driving up costs and impacting overall carbon intensity.

NET Power has emerged as a leader in solving the major challenges of large-scale DAC deployment and can accelerate the economic case for direct carbon removal. NET Power is also exploring integration with chemical production facilities that have both on-site power demand and a utilization opportunity for the CO₂ produced in the Cycle.

Another application for NET Power's technology is in replacing retiring baseload plants. Approximately 500 GW of natural gas, coal, and nuclear retirement candidates in the United States are within 40 miles of CO₂ storage. This proximity, coupled with NET Power's unique ability to leverage brownfield facilities due to its compact footprint, means an extraordinary number of brownfield sites can be repowered with clean, dispatchable, and low-cost NET Power facilities. NET Power has received significant inquiries from independent power producers and electric utilities, especially in regions with high VRE production or retiring baseload assets.

NET Power is uniquely positioned to deliver the energy trifecta of low-cost, reliable, and clean electricity and has established the partnerships and pathways to deliver on this mission. NET Power has successfully demonstrated its technology at the 50 MWth scale and will soon deliver its first utility-scale 300 MW Class facility. The company, along with its commercial and technical partners, are accelerating the energy transition and the CCUS market.



ENZYMATIC CARBON CAPTURE NOVOZYMES

SUMMARY

Amines enable you to capture carbon efficiently. But did you know there is an equally efficient solution for carbon capture that is truly sustainable? It also can cost less. By replacing amines with a powerful biocatalyst – enzymes – you not only avoid the risks associated with toxic chemicals. You can reap the rewards for decades.

Enzymatic carbon capture is a proven technology that can make your process more reliable, efficient and sustainable.

If your plant – like many – produces waste heat, you have an especially compelling reason to use biocatalysts.

Novozymes and Saipem (see separate listing) have joined forces to deliver carbon capture solutions based on enzyme (biocatalyst) technology. Novozymes is the world leader in industrial enzymes and has unmatched expertise in solving industrial challenges with biotechnology. Saipem is a carbon capture process and equipment expert with more than 60 years of demonstrated expertise in EPC.

Together we are changing the future of carbon capture. Together we can improve yours.

BENEFITS

Enzymatic carbon capture is reliable

- Requires less equipment, lowering the risk of potential downtime
- Involves no prototype equipment – everything is built at scale
- Avoids the risk of more stringent regulatory requirements

Enzymatic carbon capture is efficient

- Yields high purity CO₂ (≥ 99%)
- Can capture > 95% of CO₂ in flue gas
- Runs on less costly, low-grade residual heat
- Involves less equipment to build, operate and maintain
- Tolerates flue gas contaminants (no pre-treatment necessary)

Enzymatic carbon capture is sustainable

- Uses a non-toxic, biodegradable solvent
- Produces no toxic waste and forms no toxic aerosols
- Solvent relies on a renewable resources in the production

DESCRIPTION

ARE AMINES WORTH THE RISK?

The overall process of amine-based carbon capture is sound. However, its dependence on toxic chemicals is steeped in uncertainty.

Some of the current risks you face with an amine-based system:

- The energy-intensive high temperatures required for the process are costly. Amines have a parasitic load (energy penalty) of 20-30% for CO₂ capture; experts forecast that amine systems can get only 10-20% more efficient.
- The toxic degradation products generated need additional handling.
- More – and more costly – equipment is required than with our biotech-enabled alternative. More equipment equals higher maintenance costs and greater downtime risks.
- Worker health issues can arise.
- Amines, produced from the hazardous chemicals ethylene oxide and ammonia, strain Earth's limited resources.

Longer term, it also pays to consider these risks:

- Regulations are likely to change as the push to achieve net-zero emissions intensifies and more plants use amine-based carbon capture.
- Meeting the IPCC's goal of capturing 1,000 million tonnes CO₂ in 2030 will require doubling amine MEA production. What will regulators say to twice as many amines based on hazardous chemicals flooding the market every year?
- Will you be allowed to keep using chemicals in the same way? Will you want to? Where will plants displace millions of tonnes of amines and other second-generation solvents?
- Pressures on processing and processing equipment are likely to increase, putting more limits on your plant, wastewater stream and sludge.

BIOTECHNOLOGY IS TRANSFORMING INDUSTRY

Novozymes already helps more than 30 different industries boost efficiency and sustainability with enzymes (biological catalysts). Enzymes are proteins found everywhere in nature. When one substance needs to be transformed into another, nature uses enzymes to speed up and control the process.

For example, our industrial enzymes have been enabling low-carbon fuel technologies and sustainable biorefining for decades.

REPLACE AMINES WITH BIOTECHNOLOGY

To minimize the risk and maximize the value of carbon capture, forward-thinking businesses are considering replacing toxic amines with biocatalysts.

This proven biotechnology, called enzymatic carbon capture, is powerful enough to meet the toughest industrial challenges. And it's sustainable enough to stand up to the toughest scrutiny.

BIOCATALYSTS BENEFIT YOUR BUSINESS TODAY AND TOMORROW

Enzymatic carbon capture delivers CO₂ absorption capacity and kinetics on par with amine solutions. It has a capture efficiency of above 95% with CO₂ purity of >99%.

Biocatalytic enzyme technology can strip CO₂ at lower temperatures, saving valuable energy. Unlike the amine-based approach, enzymatic carbon capture does not require costly, energy-consuming steam. Instead, it consumes a low level of the plant's energy output, translating into up to 20% lower energy costs if waste heat is available.

You also have less equipment to build, operate and maintain with enzymatic carbon capture and there's no prototype equipment – everything is built at scale, simplifying implementation.

There are no worker health issues to handle and no need to clean the wastewater when replacing solvent with a benign salt solution and biodegradable enzymes. No toxic degradation products or aerosols need handling or cleaning. Operators face fewer risks.

ONLY NOVOZYMES AND SAIPEM CAN DELIVER A BIOLOGICAL SOLUTION THAT STANDS UP TO YOUR TOUGHEST CHALLENGES

Our enzymatic carbon capture process is very similar to the established post-combustion process – it simply replaces toxic amines with biocatalytic enzymes. And, it requires less equipment.

The novel catalyzed solvent solution offers strong

chemical stability, non-toxicity, non-volatility and low-grade temperature regeneration.

The catalyst is an enzyme type used by all living organisms to regulate CO₂. Called carbonic anhydrase, this biocatalyst is used in the absorber, along with carbonate. When the flue gas passes through the absorber, the enzyme converts the CO₂ to bicarbonate, binding it in the bicarbonate. When the circulating bicarbonate fluid reaches the stripper, it must be heated to only 75°C to release the CO₂ – rather than the 100°C required for amine-based carbon capture.

Enzymatic CO₂ regulation has been evolved by nature over millions of years. Highly efficient, the carbonic anhydrase enzyme provides 1 million catalytic reactions per second per molecule.

Our unique partnership combines Novozymes' cutting-edge enzyme expertise with Saipem's unmatched carbon capture processes and equipment know-how. Saipem supplies the carbon capture process and equipment; we supply the enzymes that optimize the process.

We bring our game-changing catalyzed solvent technology and world-class project delivery capabilities. Thanks to our global supply chain and technical expertise, we have a track record of delivering reliable solutions to industry for more than 70 years.

YOU CAN START YOUR CARBON CAPTURE PROJECT NOW

Enzymatic carbon capture offers the same level of maturity (TRL-8) as advanced amine and other second-generation solvents but has much greater potential.

Saipem and Novozymes are offering both "CO₂ Solutions by Saipem" to the market and "Bluenzyme," a standardized, modular turnkey solution that reduces implementation from 3 years to 1.5 years (see Saipem listing for details).

Now you can achieve your decarbonization goals with operationally and environmentally sustainable technology. Enzymatic carbon capture from Novozymes and Saipem minimizes your risks and maximizes value.

The technology behind "CO₂ Solutions"

Simply better

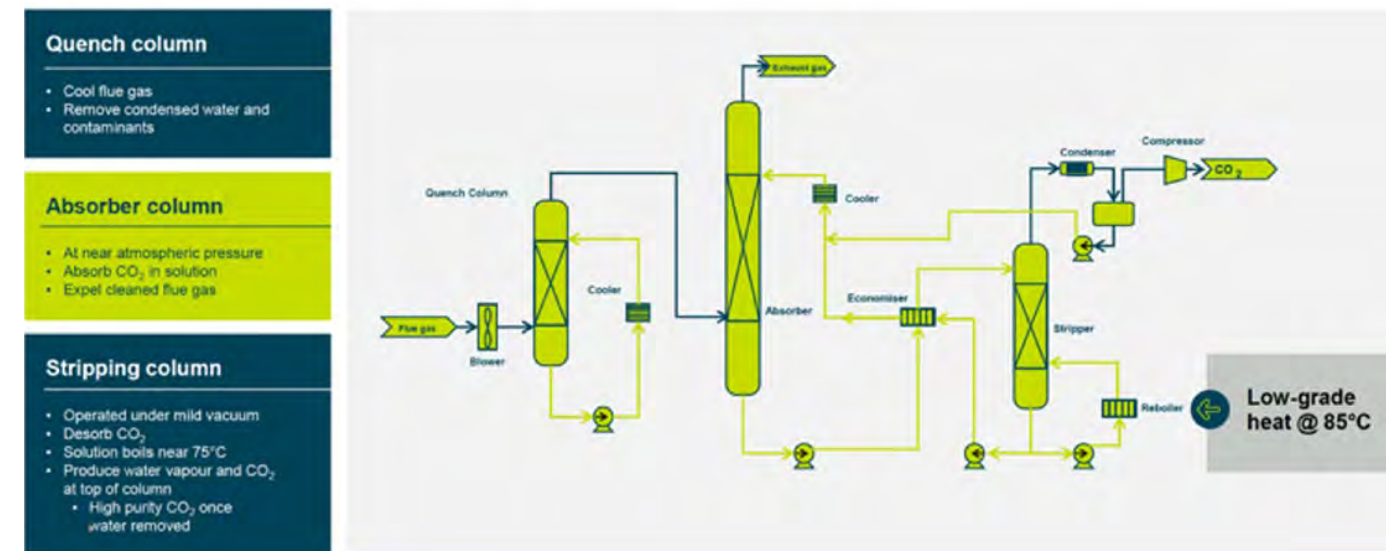

Novozymes' industrial enzymes are used at pulp and paper mills around the world to reduce the use of harsh chemicals such as chlorine dioxide in pulp bleaching.



THE NEXT GENERATION OF CARBON CAPTURE TECHNOLOGY

NUADA

SUMMARY

Nuada is a vertically integrated carbon capture company that strives to decarbonize hard-to-abate sectors through its proprietary next-generation technology. Nuada deploys filtration machines by combining advanced solid adsorbents (Metal-Organic Frameworks or MOFs) with proven vacuum swing technology (VPSA) to vacuum CO₂ out of industrial emissions through a “heatless” and solvent-free process. This represents a step change in innovation and yields an ultra-energy efficient system that reduces the energy penalty by up to 80% compared to

incumbent solutions. Nuada has successfully demonstrated its advanced CO₂ capture technology at bench scale and is now piloting the technology to the field with the backing of the Global Cement & Concrete Association (GCCA) and leading cement companies. The first pilot plant will be installed and tested in Buzzi Unicem’s cement plant in Monselice (Italy) in the summer of 2023, while Nuada is actively discussing demonstration campaigns in other suitable sectors such as steel, waste-to-energy, and blue hydrogen.

BENEFITS

- **Ultra-Energy Efficient:** By using pressure instead of heat to separate CO₂, the energy penalty is reduced by up to 80% compared to incumbent solutions.
- **No Complex Integration:** No steam is required; The machines are powered solely by electricity and can be easily integrated into existing processes.
- **Mature Process Technology:** The manufacturing capabilities and supply chains already exist for rapid large-scale deployment, unlike other 2nd generation technologies. VPSA is a mature and proven separation technology that has been industrially applied at scale for decades.
- **Flexible Applications:** The use of very selective MOF sorbents enables to treat a broad spectrum of off-gases and capture CO₂ from multiple point sources.

- **Scalable:** The modular nature of the technology provides the flexibility for capturing CO₂ at different scales and de-risking carbon capture investments.
- **Minimum environmental impact:** The filters consist of stable solid sorbents with minimum environmental impact, unlike solvents which can evaporate and release hazardous emissions.

DESCRIPTION

A STEP-CHANGE IN INNOVATION

Carbon capture is central to any realistic plan for decarbonizing hard-to-abate sectors, according to the International Energy Agency (IEA). However, the Intergovernmental Panel on Climate Change (IPCC) states that “deployment of carbon capture lags severely behind the schedule required to meet global climate mitigation targets”. Traditional liquid amine systems are currently the go-to method for capturing CO₂, however, the extreme amount of energy required to regenerate the solvents results in a cost barrier that has been prohibitive to the technology’s widespread adoption. Nuada has developed a patented, ultra-energy efficient carbon capture technology that overcomes these deployment barriers and enables end-users in hard-to-abate industries to achieve their Net Zero targets whilst minimizing the impact on their bottom line.

Nuada is building advanced filtration machines that utilize ground-breaking MOF solid sorbent materials and operate via vacuum swing adsorption (VPSA) - a mature already scaled, gas separation technology. The technology enables the efficient separation of CO₂ from process emissions via a “heatless” and solvent-free process. By using pressure rather than heat, the energy requirements for carbon capture decrease by up to 80% versus the state-of-the-art scrubbing solutions. This represents a step change in innovation that slash the operating costs that long held back the mass adoption of carbon capture in hard-to-abate industries.

Nuada’s technology is an end-of-pipe (EoP) solution designed for point-source carbon capture. During the process, the CO₂-rich flue gas is conditioned and routed to the carbon capture unit where carbon dioxide is selectively captured by the MOF filters. The lean flue gas returns to the stack to be released into the atmosphere. Once the MOF filters are suitably saturated, they are regenerated by using vacuum (instead of heat) and release the captured CO₂ into a high-purity stream, ready for downstream operations. During this regeneration, the CO₂-rich feed gas is diverted to another parallel column, yielding a continuous removal process.

NUADA SCOUT – TAILORED PILOTING PROGRAMMES

Nuada is offering tailored pilot programmes through Nuada Scout, a service that helps industrial emitters to assure their decision-making on carbon capture investments with accurate field data. Nuada Scout is an end-to-end testing service that allows industrial emitters to experience

the benefits of Nuada’s advanced carbon capture technology through a short demonstration campaign. This comprehensive service includes transport, installation, operation, testing, and decommissioning of a pilot plant configured to site-specific flue gas. Nuada Scout provides a prefabricated, containerized plant for quick and accurate in-field assessment of Nuada’s carbon capture technology. This ISO container carries the core unit operations needed to evaluate carbon capture at a 1tpd (one tonne per day) scale, with scope to bolt-on post-treatment packages for full chain CCUS (carbon capture, utilization, and storage) assessments. The installation of this plant-in-a-box requires little site preparation and minimal utility usage. All needed to get started is the plant’s emissions plus an electrical supply. Emitters can benchmark Nuada’s ultra-energy efficient technology using real in-field data and verify the benefits through a short and tailored test programme. This resource-efficient testing service provides the benefit to gain critical operational insights and de-risk investment decisions when selecting the optimal technology for a plant.

CAPTURING THE FUTURE

Nuada has formed partnerships with the Global Cement and Concrete Association (GCCA) and leading cement companies such as Buzzi Unicem, Cemntir Holding, and Heidelberg Materials, to pilot test the technology in their cement production sites. The first pilot plant by Nuada will be operational during the summer of 2023, with trials starting from Buzzi Unicem’s cement plant in Monselice, Italy. Additionally, Nuada is actively discussing demonstration opportunities with other suitable sectors as steelmaking, waste-to-energy, and blue hydrogen production, to verify the technology’s in-field performance and flexibility for treating various off-gas streams. Successful demonstrations would help establish Nuada’s presence in the CCUS market and expedite the technology’s commercial deployment. Compared to other next-generation technologies, the scale-up route for Nuada is less challenging since the manufacturing capabilities and supply chains for VPSA systems are readily available to facilitate rapid large-scale deployment. Moreover, Nuada has successfully scaled up the in-house sorbent production, being already able to meet the material requirements of commercial-scale units.



CONTACT

Justin Swain - justin.swain@shell.com
Julie Cranga - julie.cranga@technipenergies.com

www.shell.com
www.technipenergies.com



CANSOLV™ CO₂ CAPTURE SYSTEM SHELL & TECHNIP ENERGIES ALLIANCE

SUMMARY

Shell Catalysts & Technologies, in partnership with Technip Energies, offer a leading, amine-based, high-capacity post-combustion carbon capture technology, CANSOLV™ CO₂ Capture System, that is robust and proven, and has an established record of performing cost-effectively in a range of industries. Shell's CANSOLV™ CO₂ Capture System captures up to 99% of the CO₂ from post-combustion streams, for example, from power stations, waste-to-energy units, cement processing, chemical plants and other industrial facilities.

As a standalone, low-pressure, CO₂ capture technology, CANSOLV™ CO₂ Capture System is well-suited for either retrofitting to existing plants or including in greenfield developments. It uses a regenerable proprietary amine to capture CO₂ that is released as a pure stream, which makes the technology highly suitable for CCS projects. Following technical and economic evaluations, capturing

CO₂ from flue gas using the CANSOLV™ CO₂ Capture System may emerge as the preferred option because of the key features such as:

- CO₂ purity: The high purity CO₂ product enables CCS or utilization downstream of the plant.
- Adaptability: The standalone system is highly adaptable to retrofit scenarios and greenfield projects, a wide variety of industrial applications, gas flow rates and CO₂ concentrations. Units have been designed for CO₂ concentrations from 3.5 to 27% and treating gas flow rates from 11,000 to 4,500,000 Nm³/h.
- Asset integrity: The system has been designed for reliability through its high turndown capacity and the solvent's resistance to oxidative and thermal degradation.

- Low waste: The process uses a regenerable solvent, so very little waste by-product is generated, which can reduce project costs as the effluents are minimal.
- Low operating costs: The system offers cutting-edge performance. For example, its low parasitic energy consumption, fast kinetics and low volatility help to reduce the cost of operation and amine consumption.
- Track record: The technology is proven in large-scale CCS applications, having captured more than 5 Mtpa CO₂ from a power station flue gas in Canada since its start-up in 2014.

Technip Energies support integration of CANSOLV™ CO₂ Capture System into both new build and existing plants. With a strong focus on optimum heat and energy integration, intelligent use of space and tie-ins, enhanced constructability and construction methodologies and project management excellence, Technip Energies ensure the best possible application of CANSOLV™ System for each facility.

BENEFITS

The CANSOLV™ CO₂ Capture System can capture up to 99% of CO₂ from post-combustion streams and is proven for CCS at a 1 Mtpa CO₂-capture scale. It offers:

- a high-purity CO₂ stream suitable for sequestration or utilization projects;
- a highly adaptable, standalone system suitable for retrofitting and greenfield developments across a wide variety of industrial applications, gas flow rates and CO₂ concentrations;
- low operating costs;
- continuous technological developments to reduce capture costs and energy requirements through extensive research and development, targeted piloting and demonstration campaigns;
- optimum integration with wider plant energy, space and utilities provisions;
- pilot plant performance verification for in-situ flue gases for every type of emitter;
- wide range of unit sizes, from small and mid-sized modular offerings through to large-scale bespoke designs;
- project execution and construction management excellence.

Shell Catalysts & Technologies and Technip Energies have been working as an alliance since 2012, developing continuous technology improvements to enhance performance and reduce both capital and operational expenditure. We have been working in partnership to deliver a wide range of carbon capture unit sizes and offerings, to meet the needs of every emitter. Our pilot plant facilities offer in-situ testing and performance verification for all types of flue gas, whereas our small to mid-scale modular and containerized units deliver cost and schedule enhancements and project execution risk reduction in comparison with conventional bespoke approaches. Our robust, large-scale bespoke designs have been proven to cater to the most complex of projects and world first applications.



DESCRIPTION

PROCESS DESCRIPTION

Figure 1 shows the CANSOLV™ CO₂ Capture System. The key steps are:

1. Feed gas is quenched and saturated in a circulated water pre-scrubber.
2. Gas contacts the lean amine solution in a counter-current mass transfer, packed absorption column.
3. CO₂ is absorbed and the treated gas exits to atmosphere.
4. Midway along the column, partially loaded amine is removed from the tower, cooled and reintroduced over a layer of mass-transfer packing.
5. CO₂-rich amine from the absorption column is pumped through a lean–rich amine heat exchanger and then on to the regeneration column.
6. Rising, low-pressure saturated steam in the column regenerates the lean amine solution. CO₂ is recovered as a pure, water-saturated product.
7. Lean amine is pumped from the stripper reboiler to the absorption column for reuse in capturing CO₂.
8. The CO₂ is directed to by-product management systems.
9. Energy is recovered through a system such as a mechanical vapour recompression compressor and/or a condensate flash, which helps to reduce the net reboiler duty requirements for amine regeneration.

PROOF POINT: SASKPOWER 1 MTPA CCS PROJECT

Because of tighter regulations, SaskPower needed to reduce CO₂ and SO₂ emissions at its Boundary Dam power station in Saskatchewan, Canada, which is a significant source of power for the region. After carefully evaluating a range of technical options, SaskPower chose to add a CANSOLV™ SO₂-CO₂ Integrated Capture System for combined carbon capture and flue-gas desulphurization. It opted to do this for a 150-MW unit that was due for refurbishment. This involved adding a 55-m-tall CO₂ absorber, a 40-m-tall CO₂ stripper, a 31-m tall SO₂ absorber and a 17-m-tall SO₂ stripper. In 2014, the power station became the first in the world to successfully use CCS at scale. The plant has been in operation now for over 7 years with the capacity to capture up to 1 Mtpa CO₂, thereby

helping SaskPower to meet strict Canadian regulations on CO₂ emissions from coal-fired power stations and thus retain its licence to operate. The CO₂ is compressed, transported through pipelines and permanently stored in deep geological formations as part of an enhanced-oil-recovery operation. The captured SO₂ is converted to 60 t/d of a marketable sulphuric acid that can be used as a feedstock for the local fertiliser industry. The learnings from this still-operating, first-of-a-kind deployment continue to help develop Shell's CANSOLV™ CO₂ capture system and promote and develop CCS projects globally.

PROOF POINT: POLARIS CCS PROJECT

Shell's CANSOLV™ CO₂ Capture System has been selected for the proposed Polaris CCS project, one of a series of low-carbon opportunities being explored to decarbonize the Scotford complex, Alberta, Canada, to create one of Shell's proposed five global energy and chemicals parks. The initial phase is expected to start operations in about the middle of the current decade, subject to a final investment decision by Shell, which is expected in 2023. Polaris would have storage capacity of about 300 million tonnes of CO₂ over the life of the project. When fully built, Polaris would contribute to the region becoming a blue hydrogen hub.

PROOF POINT: HAFSLUND OSLO CELSIO CCS PROJECT

Shell Catalysts & Technologies and Technip Energies are supporting Hafslund Oslo Celsio to build the world's first carbon capture facility on a waste-to-energy plant as part of a full value chain, with transportation and permanent storage. The carbon capture plant at the waste to energy facility in Oslo will reduce the city of Oslo's fossil CO₂ emissions by 17%. As their partner from initial concept through to construction, Shell Catalysts & Technologies and Technip Energies are assisting Hafslund Oslo Celsio to turn their ambition into commercial reality. With the opening ceremony on site in September 2022 and laying the initial groundwork for the commercial plant, Shell Catalysts & Technologies and Technip Energies are now continuing their joint journey to final project delivery and operation by 2026.

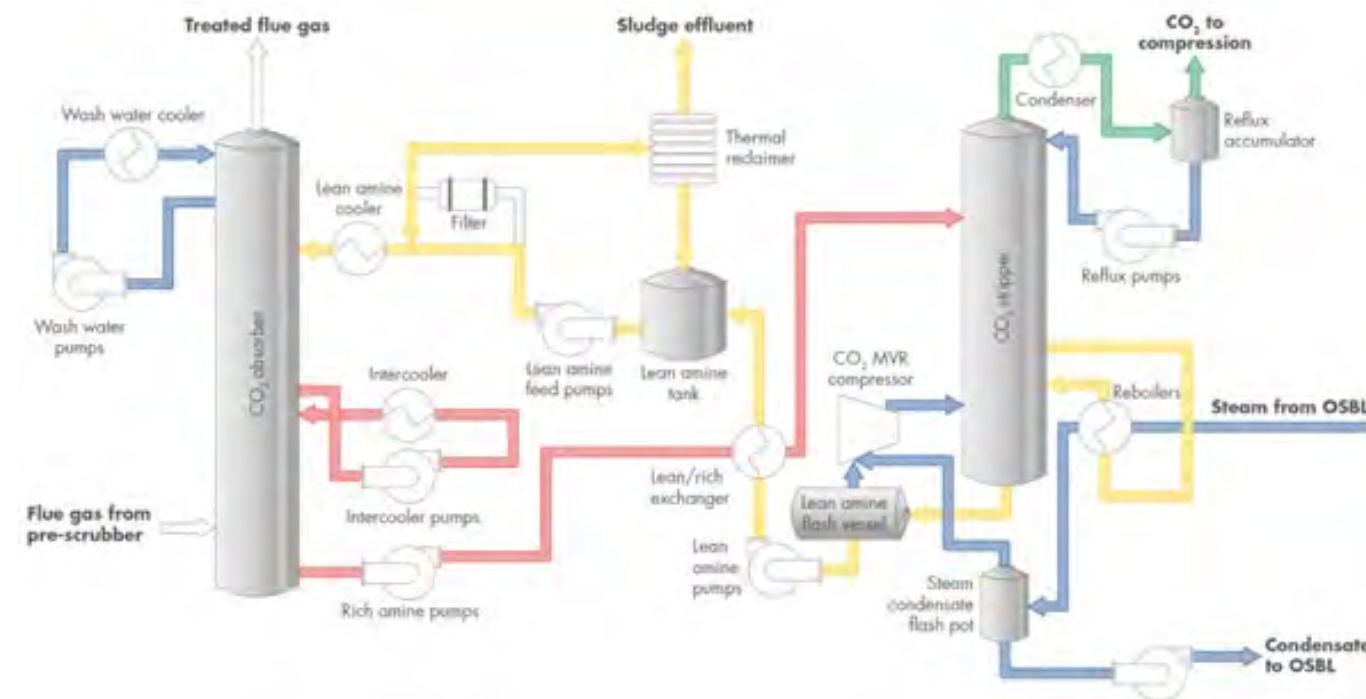

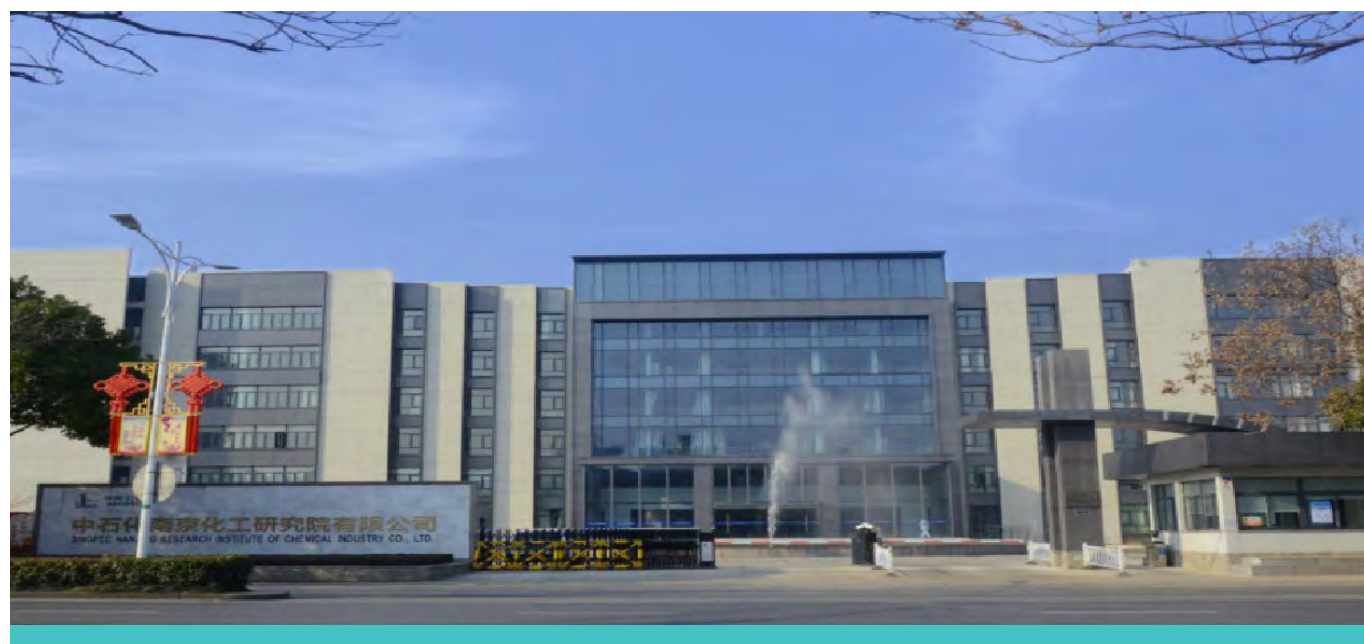

NAME OF TECHNOLOGY

SINOPEC NANJING RESEARCH INSTITUTE OF CHEMICAL INDUSTRY CO., LTD

SUMMARY

SINOPEC Nanjing Research Institute of Chemical Industry Co., Ltd. (NRICI) was founded in 1958, formerly known as Nanjing Chemical Industrial Institute of the Ministry of Chemical Industry, is a technology enterprise specialized in the research, development, design and production of the chemical products.

NRICI has long been committed to the research and development of CO₂ capture and utilization technology.

Presently, 3 types of CO₂ capture technologies have achieved mature industrial applications, including CO₂ capture technology for low partial pressure flue gas, NCMA decarbonization technology, catalytic hot carbonate decarbonization technology. Besides, NRICI is developing new carbon capture and utilization technologies, such as new solvents, membrane separation, chemical and mineralization utilization, etc.

BENEFITS

- **Rich experience in carbon capture engineering**, able to skillfully solve various problems encountered during the operation of industrial carbon capture units.
- **Well established testing and analysis facilities**, able to carry out various small- scale and pilot- scale test studies in the field of carbon capture and utilization
- **Continuous R&D capability**, able to continuously optimize and improve the existing carbon capture solvents, processes and equipment.
- **Advanced technology user**, overall at a domestic leading international advanced level in the field of carbon capture technology.
- **Customised Technology solutions**, provide the best technical solutions to obtain the most economical and efficient carbon capture products according to customer needs.

DESCRIPTION

CO₂ CAPTURE TECHNOLOGY FOR LOW PARTIAL PRESSURE FLUE GAS

NRICI started the research on CO₂ capture technology for low partial pressure flue gas as early as 1980s. With MEA solvent as the main body, in response to the problems of corrosion and degradation of flue gas carbon capture units in the industry at that time, NRICI has developed the corresponding corrosion inhibitor and antioxidant system and formed the first generation of flue gas carbon capture solvent and technology, which was successfully applied in the flue gas CO₂ recovery unit of natural gas boiler in Guizhou Chitianhua Group in 1999. After that, it has been applied in Huaneng Beijing Thermal Power Plant 3000 t/a CO₂ recovery unit and Huaneng Shanghai Shidongkou Power Plant 120,000 t/a flue gas carbon capture unit, which has promoted the development of CCUS in China.

By 2015, NRICI successfully screened a high-efficiency and low-energy capture solvent MA-1 after basic research, lab scale test and 5Nm³/h test research. After industrialized pilot study on 40,000 t/a CO₂ capture unit in Shengli Power Plant, it successfully carried out industrialized application in Sichuan Vinylon Plant, and the results showed that, compared with the original MEA method, the solvent circulation volume decreases by 34.7%, the regeneration energy consumption decreases by 41.8%, the consumption of circulating water is reduced by 200 t/h, and the cost is significantly reduced under the condition that the production requirements are met.

By 2020, NRICI continued to optimize the solvent and technology, and successfully developed a new high-efficiency and low-energy capture solvent MA-2. According to the results of the small-scale and pilot-scale test study, the comprehensive performance of this solvent is better than other existing absorption systems on the market, and finally applied to the largest coal-fired power plant flue gas carbon capture unit in operation in China - Guohua Jinjie Power Plant 150,000 t/a flue

gas carbon capture unit. The application result s howed that under the optimized test conditions, the capture rate is 96%, the regeneration energy consumption is <2.4GJ/tCO₂, and the operating loss is ~1.0kg/tCO₂, and the overall level reaches the international advanced level.

NCMA DECARBONIZATION TECHNOLOGY

NRICI started research on polyamine decarbonisation technology from the 1980s and developed the NCMA decarbonisation technology in 2003. Through proprietary decarbonization solvents, flexible process flow and precisely matched process parameters, NCMA decarbonisation technology is able to achieve customized requirements for CO₂ content in purified gas, down to meeting the requirements for CO₂ in the feed gas to deep-cooled separation systems such as LNG, and outperforms similar products in the industry in terms of corrosion and foaming. NRICI's NCMA decarbonisation technology has been successfully applied to more than a hundred decarbonisation units from different gas sources, extensively proving its fine balance between decarbonisation performance and energy saving and consumption reduction. Typical applications include the natural gas decarbonisation unit at Songnan gas field, the synthesis gas decarbonisation unit at Chongqing Fuyuan fertiliser plant, the drygas decarbonisation and desulphurisation unit at Wuhan Petrochemical refinery, and the blast furnace gas decarbonisation unit at Xinjiang Bayi Steel.

CATALYTIC HOT CARBONATE DECARBONIZATION TECHNOLOGY

Depending on the type of reaction cycle gas, the current NRICI catalytichotcarbonate decarbonisation technology is mainly applied to two gas sources, the Fischer-Tropsch reaction cycle gas and the EOEG cycle gas.

In the area of Fischer-Tropsch recirculating gas decarbonisation, NRICI started the development of a pilot process package as early as 2005, and has now formed a monopoly in the field of recirculating gas decarbonisation for coal-to-oil projects in China. Typical application cases include Shaanxi Future Energy's 1 million t/a and Shenhua Ningxia Coal's 2 x 2 million t/a coal-to-oil circulating gas decarbonisation plant.

In the field of EOEG recirculating gas decarbonisation, NRICI has successfully reduced the CO₂ molar fraction of the reactor inlet gas from 4.45% to below 2% after a domestic modification at Sinopec Tianjin Branch in 2009. Subsequently, it has been successfully applied in PetroChina Xinjiang Dushanzi Petrochemical and Sinopec Maoming Branch. The application results show that the technology has achieved better performance indicators than overseas introduced technologies

NEW CO₂ CAPTURE SOLVENTS

In addition to traditional amine solvents, NRI has also carried out research and development of new CO₂ capture solvents such as ionic liquids, amino acid salts and phase change absorbent. As CO₂ capture solvents with the potential to replace amine solvents for large-scale industrialisation in the future, ionic liquids, amino acid salts and phase change absorbent have significant advantages in a reas such as loss, stability and energy consumption. At

present, the ionic liquid flue gas carbon capture technology has completed a 50Nm³/h pilot test, while the amino acid salt and phase change absorber have completed a 3Nm³/h enlarge test, and a pilot test of 50Nm³/h phase change absorbent for flue gas CO₂ capture is underway. In the future, NRI will continue to optimise and improve the formulation and process in order to realise the industrial application of the new CO₂ capture solvent as soon as possible.



Figure 1: 50Nm³/h ionic liquid pilot test



Figure 2: 3Nm³/h phase change absorber enlarge test

ADSORPTION METHOD

The adsorption method of CO₂ capture technology can effectively overcome the problems of easy volatility, high energy consumption and corrosiveness of the absorption method, which is one of the main research directions of CO₂ capture technology at present. NRI, in cooperation with Sichuan University, has jointly carried out the development of amine-loaded porous adsorbent decarbonisation technology. 1 Nm³/h solid amine adsorption for CO₂ capture has been completed, and the developed adsorbent has an adsorption capacity >160mgCO₂/g after 50 adsorption and desorption cycles, and the total energy consumption is about 2.39 GJ/tCO₂.

In addition, NRI together with Nanjing Normal University, has carried out research on integrated CO adsorption-catalytic conversion technology. Smallscale test has shown that the preferred bifunctional adsorbent has a CO₂ capture efficiency greater than 90%, a CO₂ conversion rate greater than 80% and a selectivity greater than 95%.

MEMBRANE SEPARATION METHOD

Membrane separation is a promising method for capturing CO₂ from flue gas due to its simplicity, low investment in equipment, low energy consumption, flexibility in operation and small footprint. NRI, together with Tianjin University and Dalian Institute of Chemical Physics, CAS, based on national key R&D projects, has carried out a 30Nm³ /h pilot test and a 50,000Nm³ /d industrial demonstration research. Among them, the 50,000Nm³ /d industrial demonstration is the first in China for membrane separation with independent intellectual property rights. The demonstration results showed that the CO₂ purity is >95% and CO₂ recovery rate is >80% after three-stage membrane separation, which has reached the international advanced level.



Figure 3: 50000Nm³/d membrane separation demonstration



OXYFUEL SOLUTIONS SUMITOMO SHI FW

SUMMARY

SFW's Circulating Fluidized Bed (CFB) technology can be operated in an oxygen-rich environment allowing the highly efficient recovery of heat and power. This produces a concentrated CO₂ stream readily available for capture purposes rather than the typical flue gas emitted.

By replacing air in typical energy generation units with oxygen and recirculated CO₂ rich gas, capturing emissions becomes part of the integrated energy production step. This leads to significant reduction in energy penalty typically required with capturing CO₂ from diluted flue gas.

BENEFITS

- Wide applicability to solid, gas and liquid fuels
- Increases operational flexibility compared to air-fired units
- More efficient energy generation, higher fuel capacity in similar sized air-fired units
- Low energy penalty of 1.7 GJ/tCO₂, mainly consumed in oxygen production and CO₂ compression
- Enables sector coupling and oxygen synergy with green H₂ synthesis plants, further reducing the energy penalty
- New builds for optimized Oxyfuel performance reduce equipment sizing

DESCRIPTION

OXYFUEL

Oxyfuel is a mature and robust technology based on commercially proven components. When used in plants firing carbon neutral fuels, including biomass, residues, and waste, Oxyfuel leads to overall negative carbon emissions or the production of biogenic and sustainably sourced CO₂ for further synthesis.

The technology was demonstrated at a 30 MWth facility in the Fundacion Ciudad de la Energia (CIUDEN), Spain during the 2010s, accumulating thousands of operational hours under various conditions. Subsequently, commercial development with partners led to the completion of FEED activities and development of a readily available 300 MWe Oxyfuel power plant design. SFW's engineering and R&D experts have continued to develop the solution and adapt innovations into the delivery of new carbon capture plant designs.

Oxyfuel applied in circulating fluidized beds (CFBs) allows capturing carbon and taking full advantage of the efficient circulation and management of solids and gases. Beside the fuel flexibility, CFBs hydrodynamics enable different fluidizing gas regimes, switching between air and oxyfuel mode or different oxygen enrichment levels while maintaining elevated performance of energy generation.

Oxyfuel can be applied as a retrofit in existing CFB plants or as part of a new build project. In both scenarios, the efficient energy generation leads to lower emissions per unit of energy and can increase the gross production of energy from the power plant or industrial boiler.

The technology allows sector coupling and industrial synergy, whereas by-product oxygen from hydrogen electrolysis can be utilized reducing production costs for both capturing carbon and the further synthesis of green chemicals, fuels and materials.

FEATURED PROJECT:

30 MWTH OXYFUEL PLANT IN PONFERRADA, SPAIN

SFW realized a carbon capture demonstration plant in cooperation with Endesa and CIUDEN during 2009-2017 (see picture left). SFW's ongoing project development activities in close collaboration with industrial partners aims for commercial operation starting from 2026 for Oxyfuel fired biomass and energy from waste plants.

- No additional OPEX related to solvent procurement and waste disposal
- Can be applied as part of a post-combustion capture solution such as Calcium looping (CaL)

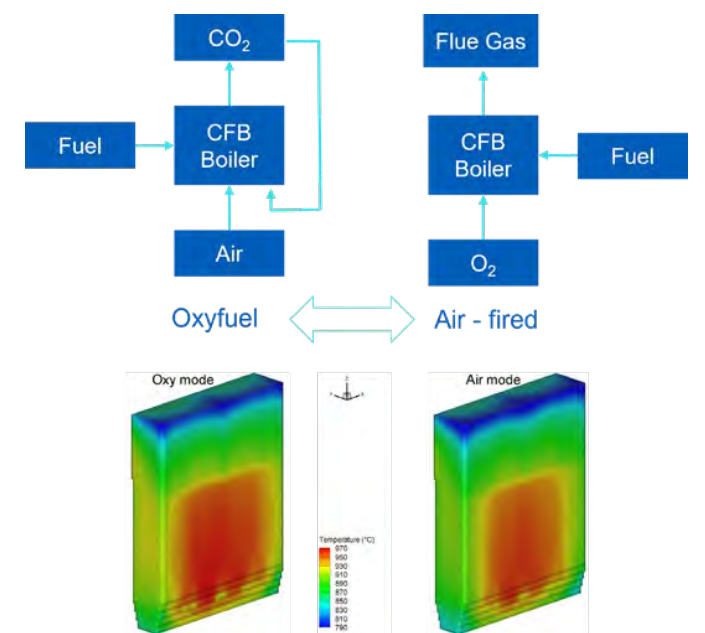
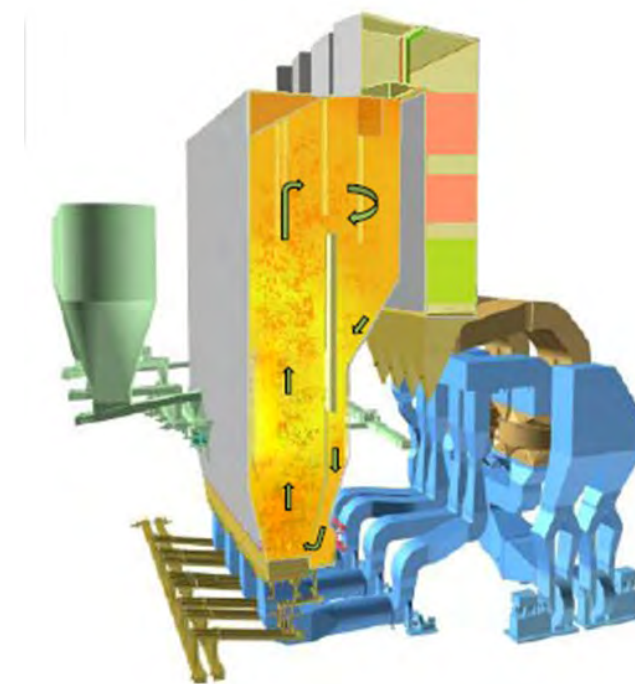

Schematic of SFW fluidized bed solutions. Source (Sumitomo SHI FW)

Gas composition and heat flux ratio in SFW fluidized bed solution in both Air fired and Oxyfuel operation. Source (Sumitomo SHI FW)

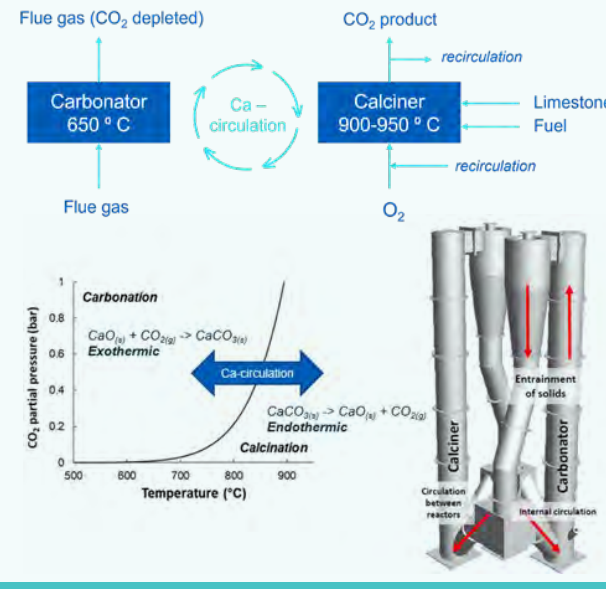

CALCIUM LOOPING SUMITOMO SHI FW (SFW)

SUMMARY

SFW's Calcium Looping (CaL) is a scalable and retrofitable post combustion CO₂ capture technology based on Circulating Fluidised Bed reactors (CFBs). The technology is built on SFW's experience of delivering over 500 CFB commercial units.

It is a cost- and environmentally effective and highly adaptable solution for capturing carbon emissions from multiple industries. With Calcium Looping technology, we at SFW serve the energy from waste, cement, steel, pulp & paper and metallurgical industries.

BENEFITS

Added value in the form of revenue streams from green electricity and lime

- CO₂ capture efficiency higher than 90%
- Lower energy penalty than from other post combustion capture technologies
- Captures other acid gases present in flue gas
- Fluidized bed can handle challenging flue gas conditions (higher temperature and level of impurities compared to liquid solvent solutions such as amine scrubbing)
- Commercially available, scalable, and cost-effective components
- Can be integrated to emission source in cement, steel and other carbon intensive industry
- Sector coupling and oxygen synergy with green H₂ synthesis plants

DESCRIPTION

CALCIUM LOOPING

Calcium looping or CaL utilizes a natural and non-toxic sorbent, calcium, to capture and release high purity CO₂. The energy required to capture CO₂ is supplied via the oxyfuel calcination of sustainably sourced bio-residues and waste.

CaL creates added value for industrial plant operators in the form of circular economy applications, decarbonizing energy generation and enabling sector coupling opportunities. In essence, CaL addresses scope 1, 2 and 3 emissions. CaL is supplied either as a tail-end configuration, capturing CO₂ and producing energy and lime, or as an integrated configuration in which the capture system exchanges material and heat streams with existing industrial units.

As such, CaL can be integrated to any industrial emission source, especially those with an existing lime cycle in operation such as cement, steel, and pulp and paper. The sorbent purged from the capture system, a mixture of lime and valuable minerals, is a viable feedstock, for the green manufacturing of construction materials.

Like oxyfuel, CaL provides synergy with green hydrogen plants, whereas cheap and available by-product oxygen is utilized for the carbon capture purposes. This leads to reductions in capture costs and the efficient synthesis of carbon negative fuels and materials.

CaL is a multiproduct technology which drives project feasibility due to numerous potential revenue streams, such as, excess electricity, high quality heat, waste gate fees, carbon removal credits, calcined lime and hydrogen or nitrogen from the oxygen production plant.

Calcium Looping has been tested and demonstrated since 2012 under industrial operating conditions at the La Pareda power plant, Spain. Sumitomo SHI FW has supplied the demonstration unit and continued to support innovation with our technical advisory services

FEATURED PROJECTS:

1.7 MW CaL demo plant in LaPareda, Spain

Supplied and commissioned by Sumitomo SHI FW in 2012, the plant (see picture left) demonstrated a capture efficiency of over 90%. The plant has continued to operate flexibly for over 5000 hours under different process conditions to optimize the technology.

CaLby2030 project for hard to abate sectors

Sumitomo SHI FW will design and engineer three integrated CaL pilot plants to be operated in relevant industrial environment across Europe. The demonstration campaigns will be carried out with the aim of exceeding 90% CO₂ capture rates and even approaching 99% in specific configurations. The demonstrated results will be then scaled up to generate concepts and basic designs for the commercial carbon capture projects for Thomas Zement's integrated cement plant in Karsdorf, Germany, Alleima's Sandviken steelworks plant in Sweden, Hunosa's LaPareda power plant in Spain and IREN's waste to energy plants in Italy.

HERCCULES project for WtE plants

SFW will engineer a CaL carbon capture plant to be installed at the Milan Silla-2 waste-to-energy plant, owned and managed by a2a Ambiente, a member of the a2a group. The plant is one of the largest Italian waste management facilities that handles around 550 000 tons of municipal solid waste and non-hazardous special waste per year. The pilot plant will operate for up to 4000 hours and the project will conclude with the design and development of FOAK commercial size facility.

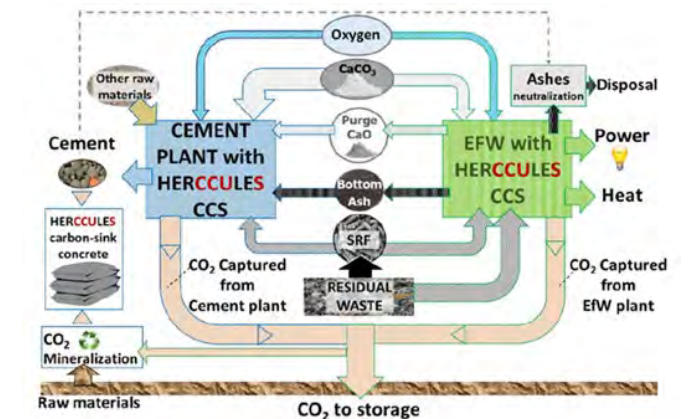

Sector coupling opportunity and material flows enabled by CaL capture system (Source: HERCCULES project)

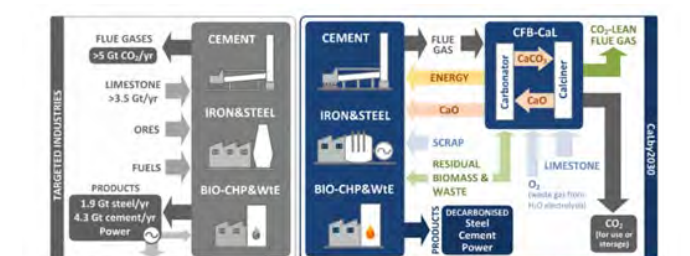

(left) Reference industries targeted in CaLby2030 and their mass flows; (right) Integrated CaLby2030 concept to avoid CO₂ emissions from high temperature industrial processes and residual-biomass-fired power plants.

CaL industrial cases examined in the CaLby2030 project (Source: CaLby2030 project)



HOT POTASSIUM CARBONATE SUMITOMO SHI FW

SUMMARY

SFW's liquid solvent based carbon capture solution is based on the well-proven Hot Potassium Carbonate (HPC) process, enabling capture rates of over 90% from industrial stacks. HPC is a widely available, low-cost, safe, and environmentally friendly solvent.

The SFW HPC solution includes the proprietary Capsol EoP® End-Of-Pipe technology for lower energy consumption in the process than comparable post-combustion capture technologies. The solutions can be powered with electricity only or a combination of power and steam, giving more flexibility in implementation.

BENEFITS

- HPC is a well-proven carbon capture process with hundreds of references and decades of operational experience in the chemical and Oil & Gas industries.
- Potassium carbonate is a widely and freely available material that is tolerant to oxygen, non-toxic, non-volatile, and non-carcinogenic.
- This makes the HPC solvent low-cost with low make-up need, reducing the solvent management cost of the carbon capture plant.
- It further ensures that the HPC solvent does not pose risks to environment and health, facilitating simpler permitting.

DESCRIPTION

HOT POTASSIUM CARBONATE, HPC

SFW's Hot Potassium Carbonate (HPC) capture technology starts with the cooling and compression of flue gas to enhance CO₂ absorption. The capture system removes CO₂ and regenerates the solvent via the following reversible reaction:

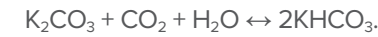

Expanding the CO₂ depleted flue gases over an expander, recovers a large part of the compression energy. The heat recuperated from the flue gas and product CO₂ streams is used internally in the capture system and the remaining heat can be exported to an available district heating network.

The SFW HPC plant is aimed at producing biogenic CO₂ from retrofitting biomass and waste to energy plants with carbon capture, creating potentially negative emissions or providing biogenic carbon for e-fuel synthesis.

The carbon capture plant can also be delivered as part of a new build wasteWOIMA® waste-to-energy plant, or be retrofitted to any other CO₂ emitting source.

- The HPC process gives a high capture rate over 90% and produces a CO₂ product and yields a high purity CO₂ product suitable for compression purposes.
- The HPC process can be powered by electricity, or a combination of steam and electricity, giving more flexibility.
- The Full Electric Capsol EoP® technology claims for a low energy consumption between 0.7 and 1.5 GJ/ton CO₂ captured and minimizes the disturbance of existing operations at the site during construction.
- The heat recovered from the HPC process can be recovered in district heating

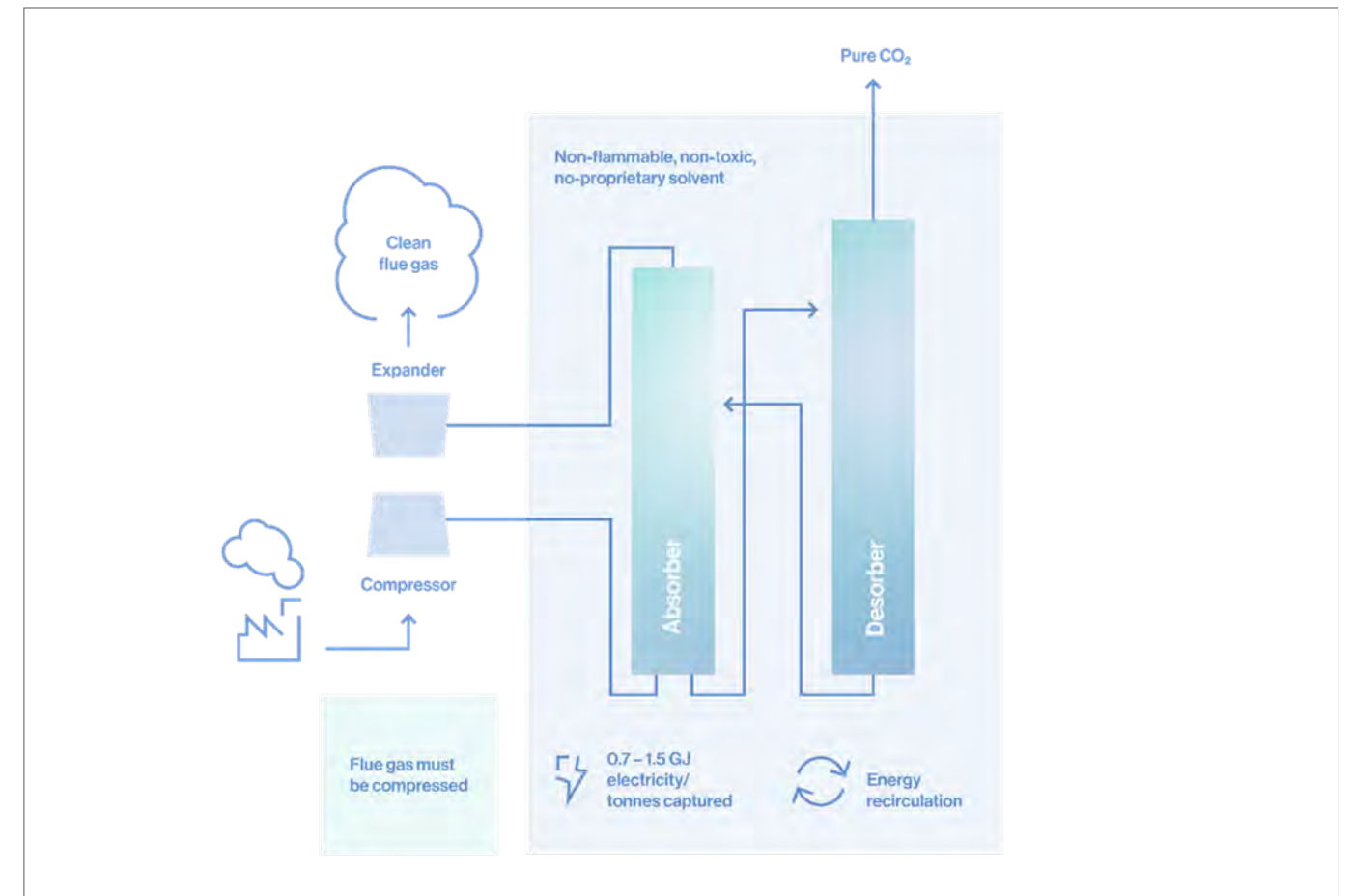

Schematic of HPC solution (Source: Capsol Technologies AS)



AMINE-BASED POST-COMBUSTION CAPTURE TECHNOLOGY

TOSHIBA ENERGY SYSTEMS & SOLUTIONS CORPORATION

SUMMARY

Amine-based post-combustion CO₂ capture is a promising technique that can be employed at large scale to various flue gases safely in order to ensure a substantial reduction in CO₂ emissions from man-made sources of CO₂ such as the power generation industry, cement industry, iron, and steel industry and so on. Based on this understanding, Toshiba has focused on developing post-combustion CO₂ capture technology since 2007 and has designed and constructed a 10- tpd CO₂ scale pilot plant at Mikawa city, Japan in September 2009 which accomplished more than 13,000 hours of operation at present with live flue gases from biomass/coal-fired thermal power plant. Through the

long operation of its own pilot plant in Mikawa, Toshiba demonstrated high reliability and stable operation under a wide range of process conditions which eventually allowed Toshiba to deploy its proven CO₂ capture technology at a commercial scale at Saga Incineration plant (10 tpd CO₂ scale) and Demonstration plant of 600 tpd CO₂ scale in Japan. Toshiba also developed and employed its own proprietary amine-based aqueous solution and efficient process techniques in aforesaid commercial projects which have shown significant reduction in CO₂ recovery energy, less degradation of solvent, and lower amine emissions.

BENEFITS

- Significantly low recovery energy demand resulting in low steam consumption
- Low solvent degradation and low amine loss resulting in longer service life
- Possess extensive experience with integrated utilities, operations and maintenance of carbon capture plant with coal/ biomass /incineration (WtE) plant.
- Applicable to both existing and new builds power plants and providing CO₂ purity in excess of 99.9%.
- Adapting to customer's demand for both full and partial CO₂ capture.
- Possess own pilot plant to carry out in-house research & development activities.

DESCRIPTION

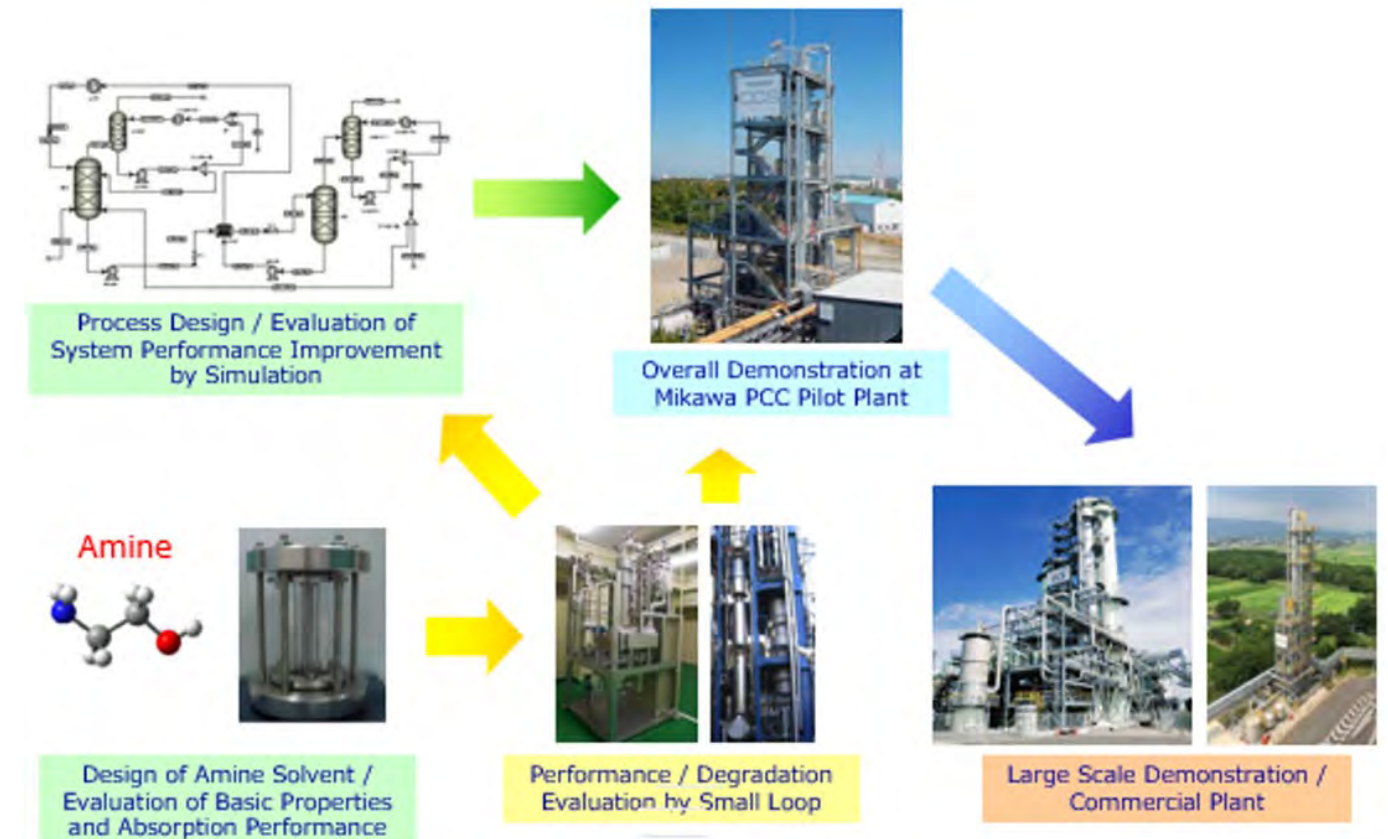

TOSHIBA'S CARBON CAPTURE TECHNOLOGY IMPLEMENTATION FLOW

Toshiba has focused on continuing research and development activities for post-combustion CO₂ capture technology and possess its own pilot plant for testing and development of high-performance amine-based solvents, efficient process design conditions, degradation evaluations and applied it to various commercial plants.

Toshiba has developed the high-performance amine solvents (TS-1), and most efficient amine emission mitigation technology which uses spray type washing system to minimize amine emissions levels which are safe for human and aquatic life in surrounding atmosphere.

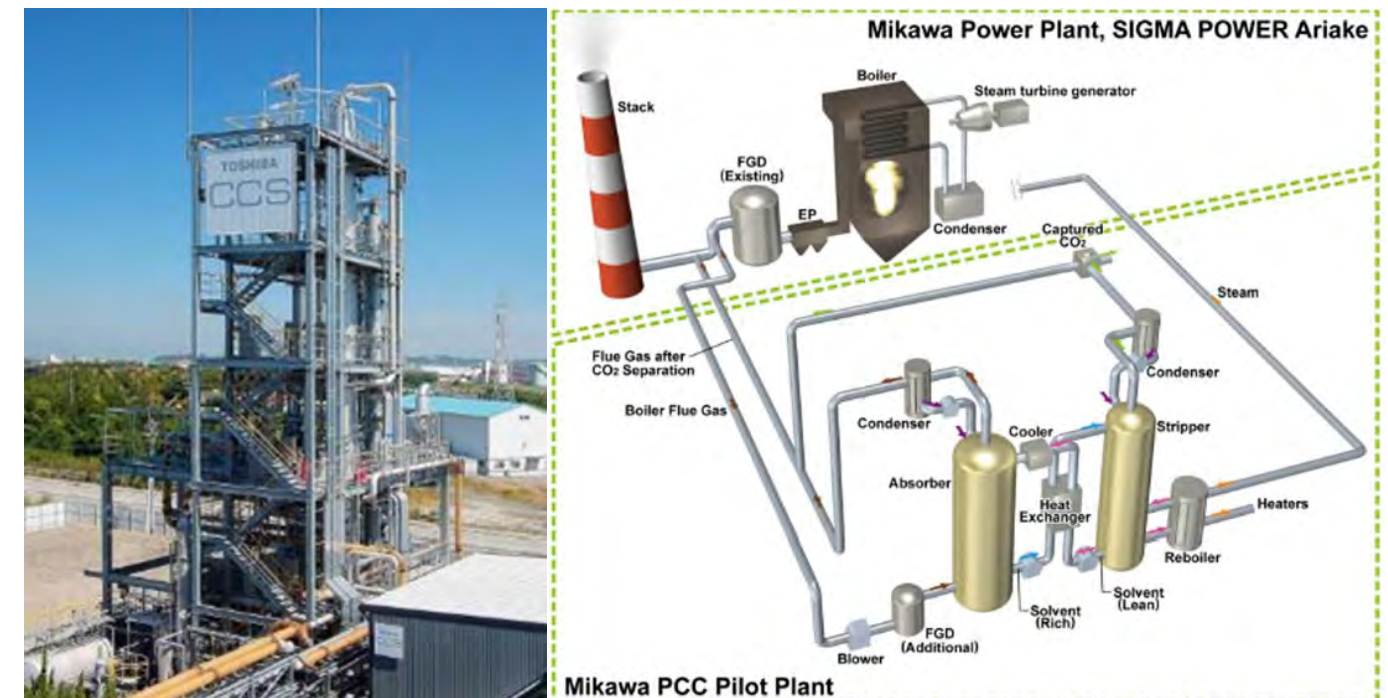

Picture of Mikawa pilot plant



Commercial Plant for CCU
(10 ton/day)

Picture of Saga CCU commercial plant

MIKAWA PILOT PLANT 10 TPD CO₂

Tested in-house developed amine based solvent performance (CO₂ capture amount, CO₂ capture rate, CO₂ recovery energy, etc.) against CO₂ gas concentration ranging from 4 to 30 vol %.

- Evaluated system improvement with various components.
- Demonstrated more than 13,000 hours of operation on a live flue gas of biomass/coal fired thermal power plant
- Achieved CO₂ recovery energy less than 2.4 GJ/ ton-CO₂ (At 90% CO₂ Capture, CO₂ Conc. approx. 12% vol)

Specification

- Location: Omuta City, Fukuoka Inside Mikawa Thermal Power Plant (Property of SIGMA POWER Ariake Co.Ltd.)
- Commenced Operation: September 2009
- Source Gas: Flue gas from biomass/coal fired thermal power plant
- Captured CO₂: 10 tpd CO₂
- Capture rate: > 90%

SAGA CCU PLANT 10 TPD CO₂

- World's first commercial-use CCU system constructed in a waste incineration plant.
- CO₂ offtake primarily used for algae cultivation and also used for cucumber cultivation as a smart agriculture.
- Accomplished long hours of operation (more than 6 years) of capturing CO₂ from live flue gases from waste incineration plant having variable CO₂ concentrations.
- Demonstrated easy integration techniques of operating CO₂ capture plant with waste incineration plant.
- Possess know-how of stable plant operation and real-time performance data including solvent degradation.
- Possess experience working as a partner to Saga city incineration plant and can act as an important partner to guide on integrated plant operation.

Specification

- Location: Saga City, Saga City Waste incineration (WtE) plant
- Commenced Operation: September 2016
- Source Gas: Flue gas from Waste incineration (WtE) plant
- Captured CO₂: 10 tpd CO₂
- Capture rate: > 90%
- CO₂ Purity: > 99.9%



Picture of Demonstration plant of Ministry of the Environment, Japan

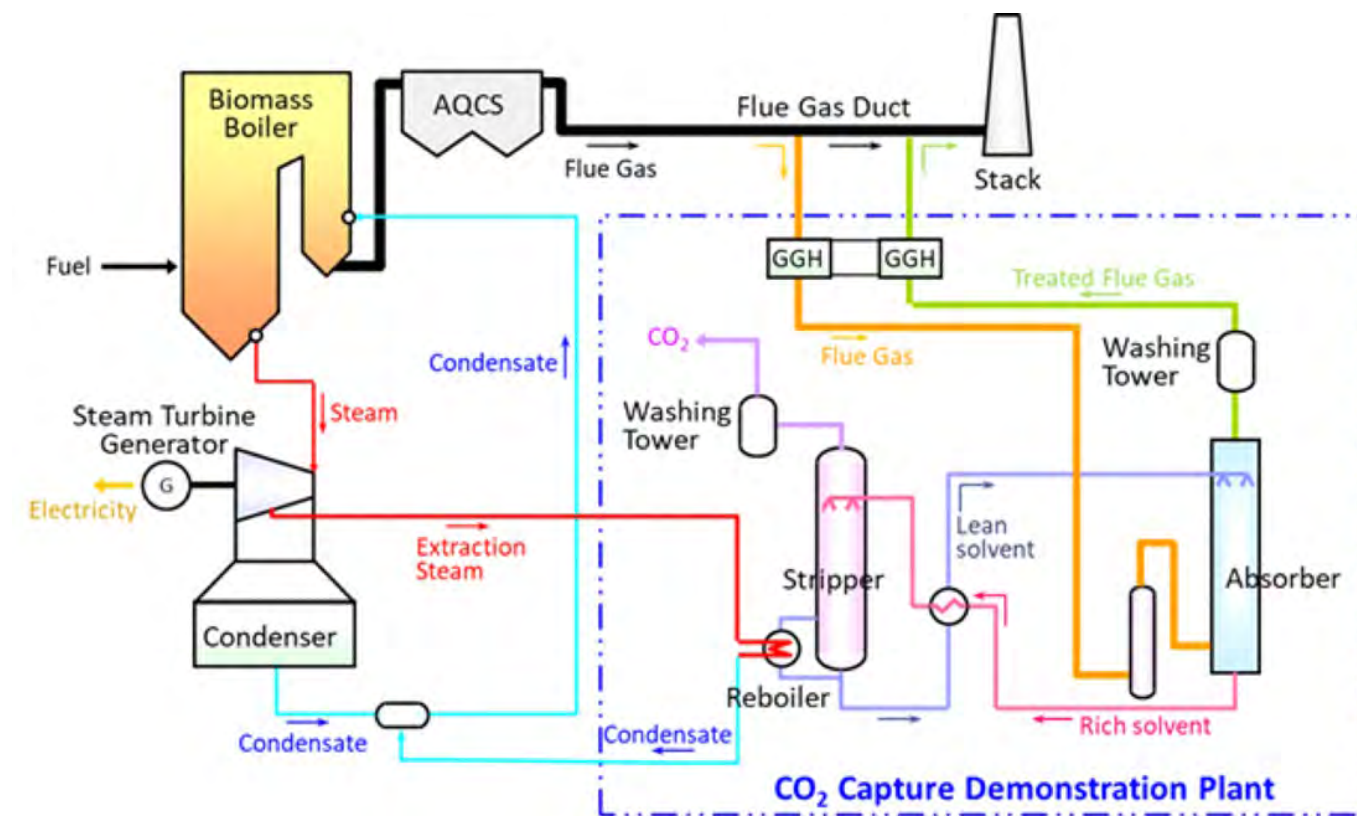

CO₂ CAPTURE DEMONSTRATION PLANT 600 TPD CO₂ OF MINISTRY OF THE ENVIRONMENT, JAPAN

- World's first BECCS ready project integrated with 100% Biomass based thermal power plant.
- This plant captures 600 tpd CO₂ from the flue gas of the Mikawa Power Plant (more than 50% of its total emissions) and is integrated with this power plant with turbine extraction steam feeding the energy for desorbing CO₂ at the stripper.
- CO₂ capture plant applied with Toshiba proprietary solvent TS-1 with CO₂ concentration as 15vol% in dry basis
- Demonstrated integrated operation of CO₂ capture plant with 100% Biomass based thermal power plant.
- This Demonstration Plant applied with Toshiba novel technology Spray type washing system that has shown drastic effect of suppressing total amine emission to the atmosphere.
- Toshiba is also the Steam turbine system supplier and has immense experience of steam turbine operation. Thus, we can integrate CO₂ capture plant with thermal power plant and have experience of integration of large size CO₂ capture plant in this Ministry of the Environment project

Specification

- Location : Omuta City, Fukuoka Inside Mikawa Thermal Power Plant
- (Property of SIGMA POWER Ariake Co.Ltd.)
- Commenced Operation : October 2020
- Source Gas : Flue gas from biomass fired thermal power plant
- Captured CO₂ : 600 tpd CO₂
- Solvent : Toshiba solvent-1 (TS-1)
- CO₂ in flue gas : 15 vol.% in dry base
- Capture rate : > 90%

THE FUTURE OF AMINE SOLVENT TECHNOLOGY DEVELOPMENT

Toshiba currently involves in developing the next generation of amine solvents that achieves low energy levels similar to TS-1, while also having characteristics of better stability (resistance to degradation) and low amine emission.

After conducting long-term testing, we plan to supply it to the market for our customers.

Specifically, regarding lower amine emissions, Toshiba intends to offer a pathbreaking technology with very low amine emission by combining Toshiba's proprietary spray technology with the low amine emission next-generation solvent.



CO₂ CAPTURE PLANT PROCESS SVANTE

SUMMARY

Capturing of CO₂ from industrial operations using chemical solvents is technically proven, but the costs in terms of capital and energy use are high and the potential for toxic chemical emissions has prompted developers to seek other technological approaches. One avenue showing promise is the use of solid adsorbents. Svante Technologies Inc. (Svante) has developed a novel solution to capture large-scale CO₂ emissions from hard-to-abate industries such as cement, hydrogen, oil & gas, aluminum, chemicals, pulp & paper, and more. The CO₂ captured can be either safely stored deep underground or used to make other products in a closed loop. Svante's post-combustion capture technology is currently being deployed in the field at pilot plant-scale by industry leaders in the energy and cement manufacturing sectors, including:

CO₂MENT Pilot Plant Project: Lafarge Canada and Svante launched this one tonne per day (tpd) project in 2019 at a cement plant in Richmond, British Columbia, Canada. The CO₂ captured here is planned to be used to make products such as sustainable aviation fuel, makeup bases, snowboard waxes, and more.

Cenovus (formerly Husky Energy): This is a 30 tpd demonstration plant, which launched in 2019 at an industrial facility in Lloydminster, Saskatchewan, Canada.

Chevron USA: Svante's latest pilot-scale project, a carbon capture plant set to capture 25 tpd came online in the Spring of 2023 in Bakersfield, California, USA.

In addition, several engineering projects for commercial-scale carbon capture projects ranging from 500 to 4,500 tpd are underway in North America and Europe.

To date, Svante has attracted more than US\$500 million in funding since it was founded in 2007, with the latest Series E fundraising round closing at a record-breaking US \$318M with Chevron New Energies as the lead investor. Other participants included new and existing investors from large entities such as GE Vernova, 3M Ventures (the venture capital arm of 3M), United Airlines Ventures, Samsung Ventures, and more.

The company is currently expanding its commercial filter manufacturing facility in Canada. In 2024, the new facility, The Centre of Excellence for Carbon Capture & Removal, located in Burnaby, British Columbia, Canada will have an annual capacity to deliver filter modules capable of removing 5 Mtpa CO₂.

Svante's energy efficient and low-cost technology, the VeloxoTherm™ carbon capture process, is an intensified rapid-cycle Temperature Swing Adsorption (TSA) system using advanced Structured Adsorbent Beds (SAB). This novel process is designed to capture CO₂ directly from industrial sources and release pure CO₂ in less than 60 seconds, compared to hours for other technologies and requiring significantly less capital cost. The capture process is implemented via a device similar to that of

regenerative air heaters widely used in power plants, in which a proprietary structured adsorbent is arranged on a circular rotating structure, known as a Rotary Adsorption Machine (RAM). The device simultaneously exposes different segments of the structure to each step of the TSA cycle. A key advancement is the development of innovative adsorbent materials, which enable the use of a rapid temperature swing cycle.

BENEFITS

- Svante's technology utilizes a single piece of compact equipment enabling a competitive reduction in capital costs compared to first generation approaches.
- Capacity is scalable in multiples of individual Rotating Adsorption Machines (RAMs) between 500 and 5000 tpd of CO₂ captured, depending on the application and product purity requirements.
- Svante's technology is flexible by using different adsorbents and can target low and high concentration industrial flue gases.
- Inherent ability to load follow and start and stop extremely quickly by easily controlling the rotation speed of the RAM. This feature enables CO₂ capture from intermittent process such as lime production PFR kilns and electric arc furnaces.
- Svante's proprietary VeloxoTherm™ process is environmentally friendly based on novel Structured Adsorbent Beds (SAB), which are not subject to nitrosamine and nitramine emissions.
- No process safety associated with new hazardous chemicals being brought onsite.
- Svante has built world-class collaborations and partnerships with world-class organizations across the CCUS value chain, including project developers, engineering, construction, and procurement companies, as well as utilization, transportation, and sequestration entities, which enables Svante's customers manage their CO₂ emissions from source to sink.

DESCRIPTION

CO₂ CAPTURE PLANT PROCESS

The Svante carbon capture process consists of a series of steps which include passing flue gas, regenerating steam, and conditioning air through structured adsorbent beds in a specific order.

1. **Adsorption:** The first step in the process is the introduction of the feed gas into the structured adsorbent beds, where CO₂ is adsorbed onto the surface of the adsorbent, while the remainder of the flue gas mainly N₂, O₂ and H₂O is sent to the stack as spent/exhaust gas.
2. **Regeneration:** The CO₂-rich adsorbent bed then rotates to a sector of the process where low pressure steam flows through it, requiring only a small amount of superheat to overcome heat losses from the system. This is the first regeneration step, where steam regenerates the adsorbent, releasing a stream composed primarily of CO₂ and steam.

3. **Conditioning:** After regeneration with steam, the bed rotates through a sector of the process where heated ambient air is used to condition and cool the structured adsorbent. The ambient air stream, termed Conditioning Gas, removes most of the water vapor from the adsorbent. The adsorption, regeneration, and conditioning functions described above are integrated and implemented in the RAM, as shown in the figure below.

Svante is on the 2023 Global Cleantech 100 and was ranked second among private companies in the Corporate Knights Future 50 Fastest-Growing Sustainable Companies in Canada. Svante was also acknowledged in the 2023 XB100, the definitive ranking of the world's top 100 private deep tech companies, hosted by XPRIZE and Bessemer Venture Partners.

For more information on Svante, visit www.svanteinc.com.

TRANSPORT



The process begins during Concept stage, by defining fundamentals such as the injection pressure of the target geo-reservoir. This stage is dominated by the process of “Steady State Hydraulics”, which allows the pipeline diameter and design pressure to be nominally set and determines the need for mainline pump station(s).

Cost estimates using factored metrics from the natural gas pipeline industry allow the pipeline to be costed at this stage and if the overall CCUS project appears attractive, then pipeline design enters the next stage- FEED.

A CO₂ pipeline FEED by GHD starts with a materials study, which identifies any special requirements such as stress corrosion cracking resistance and proposes a grade of steel that is likely to be optimal. API 5L Grade X65 is a likely starting point, however GHD checks in with pipe merchants at this stage to identify any trends in the market, which might promote a different strength steel, which may then increase or decrease wall thickness and therefore steel tonnage.

Also, during FEED, the pipeline route becomes “real”. Geographically localized threats to the safety of the pipeline are identified, as are nearby population centres. Advanced software such as PHAST™, SLAB™ and CHARM™ are utilised to simulate the release and abrupt partitioning of CO₂ its gaseous and solid (snow) ambient phases and to examine how prevailing wind and topography might transport the plume over unexpectedly long distances. The effect of contaminants such as H₂S that are potentially more dangerous than the CO₂ itself is also considered.

AS 2885 calls for a Safety Management Study to formalize this mile-by-mile risk assessment of the pipeline route, and GHD advocates this process for pipelines in all jurisdictions. The results from this process combine with further design inputs to produce a tentative wall thickness selection and the process then begins of designing the pipeline’s “fracture resistance”. A new generation of pipeline steels has appeared in the last few years. These offer stellar toughness as measured using the conventional “Charpy” test but are behaving unusually in some of the other standard material tests..



**DON'T CRACK!
BUT IF YOU DO CRACK- TRY TO PULL IT TOGETHER...**

The classic concern with CO₂ pipelines is running ductile fracture, where the pipeline “unzips” over an extended length, thus multiplying the chances that the failure and subsequent fluid release will coincide with and harm the public.

“Crack arrestors” were historically used on older pipelines, but in many cases were applied in a tokenistic way at long intervals that sometimes failed to meaningfully lower risk levels. Recent and currently planned projects rely instead in “intrinsic arrest” pipe, which will arrest running cracks within a reasonable distance. Fracture control almost always ends up determining the final wall thickness.

Leading researchers in the field have taken designers on a challenging journey since 2019. Prior to this time, CO₂ pipelines were designed using a modified “Batelle Two Curve” (BTCM) method. This method used well known software- DUCTOUGH™ to model the running crack and GASDECOM™ to model CO₂ decompression. However, it was recognised that resulting designs could be unconservative and potentially still be vulnerable to running ductile fractures.

Since then, a number of methods have been proposed in quick succession, as shown in the following diagram.

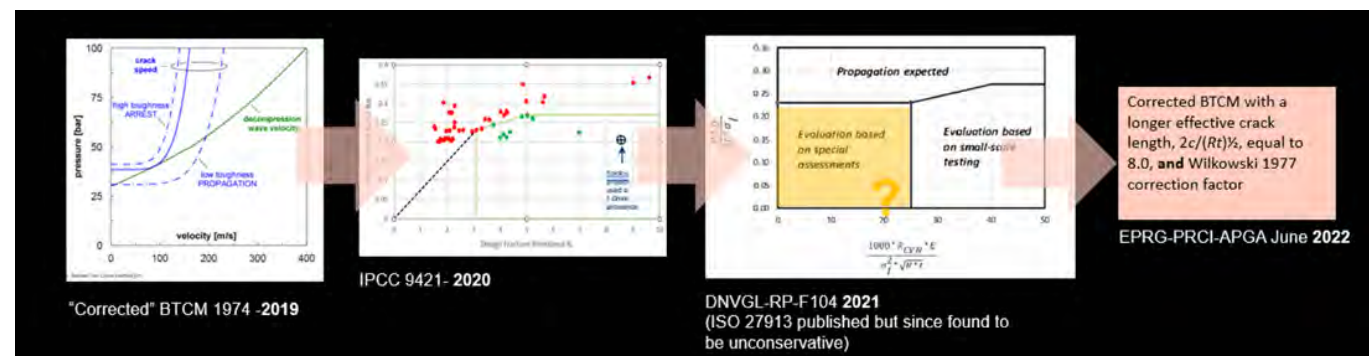

At the time of writing, proponents really face a choice between three main design outcomes:

- Employ a “conservative design”, which requires only lab-scale material tests to validate. This usually involves extra millimetres of steel, and potentially even over-sizing of the pipeline in order to be able to safely rely on the results of historical burst tests. However, it is a valid technique for shorter pipelines.
- Procure pipe samples and perform full scale burst tests- this method is likely to produce the most efficient design on large projects, but extends lead time considerably.
- Undertake “Special Assessments”, which involve highly specialised computer modelling of the running fracture. (GHD is acquainted with the very few institutions who can perform this.)

In any of these approaches, it is necessary to know the phase envelope of the CO₂ with its various impurities and then to identify the temperatures and pressures of different operating points along the pipeline and in different seasons. Special modifications to the classical equations of state may be needed to accurately predict the saturation pressure.

The designer can then predict how the supercritical or dense phase CO₂ will decompress. When the fluid saturation line is encountered, the fluid becomes a boiling liquid that evolves large quantities of CO₂ vapour, tending to maintain the pressure and causing the crack to “keep running”.

OTHER THINGS TO JUGGLE

Whilst all of this is playing out, the hydraulic modelling from the Concept stage is expanded into “flow assurance” work. This considers all the transient conditions where the real challenge in operating CO₂ pipelines occurs, such as how to start and stop the pipeline, cool-downs, and depressurization. These processes need to consider the dangers of hydrate formation, rapid free-water corrosion, and auto-refrigeration embrittlement.

These design strands weave together to culminate in the full specification of the pipe material, as well as a good understanding of the route that the pipeline traverses and how it will be built. GHD can then estimate costs more accurately and pipe material can be purchased with confidence.

The figure below shows how GHD assessed this on a recent project.

As at mid-2023, it is possible that the industry leaders are reverting to highly corrected versions of the BTCM. GHD continues to track these developments.

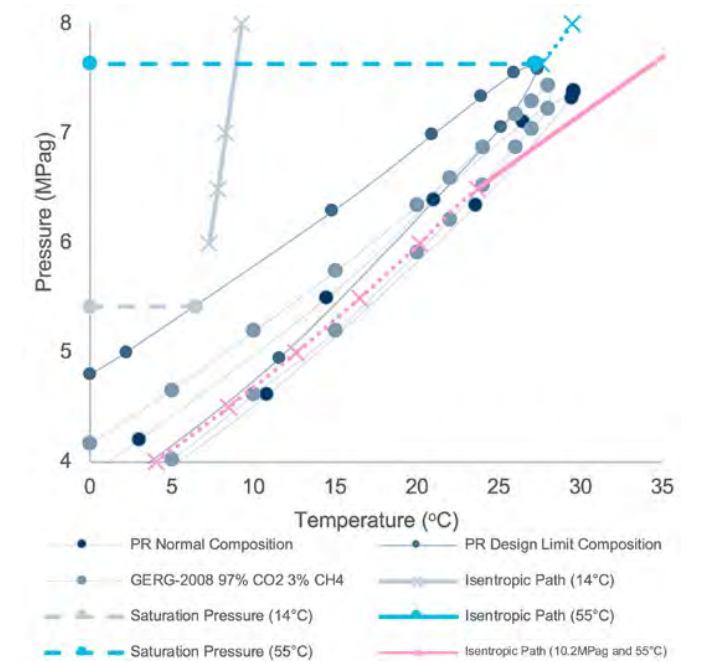

GHD reaches out to developers of CCUS projects worldwide. Our key CCUS team is based in Houston and Brisbane, Australia. We provide engineering all the way from CO₂ capture plant through to reservoir pore space. Our pipeline design work is leading-edge but resides within a complete service offering that also includes CCUS approvals and environmental work.



JFE-UHP™-15CR AND JFE-UHP™-17CR TUBING JFE STEEL CORPORATION

SUMMARY

JFE Steel has been playing a key role of supplying the oil & gas industry with martensitic corrosion resistant alloy (CRA) tubing with their own robust premium connections. With the growing global demand and necessity for carbon reduction, JFE now sets great priority on the supplying of tubing and connection for the CO₂ underground storage wells. JFE has evaluated their martensitic CRA grades including JFE-UHP™-15CR and JFE-UHP™-17CR tubing together with the JFELION™ connection for the application

in CO₂ underground storage wells, where they have shown great and promising performance for the usage. Starting from 2008, JFE has supplied the CRA tubing with their premium connections to several CCS projects globally to demonstrate the feasibility of CCS and increase the storage capacity. JFE would continue the collaboration and discussion with the customers/operators to contribute to the CCS projects.

BENEFITS

JFE-UHP™-15CR and JFE-UHP™-17CR Tubing have following benefits which could contribute the popularization of clients' CCS projects.

- Tubing with corrosion resistance against CO₂ with contaminated gas condition
- Lower cost compared to duplex stainless steel and higher CRA tubing
- Shorter delivery time compared to duplex stainless steel and higher CRA tubing
- Delivered with JFE's robust premium connection such as JFEBEAR™ and JFELION™

DESCRIPTION

JFE'S MARTENSITIC CRA TUBING

JFE Steel is an integrated steel mill, having various type of steel product lineup. JFE is also a global supplier of martensitic stainless steel, especially for Oil Country Tubular Goods (OCTG) and has wide range of expertise for steel pipe materials and connection systems. OCTG were first manufactured and shipped at JFE Steel Chita Works in 1971. Since then, JFE has been developing and supplying martensitic CRA tubing globally. Starting from first 13Cr martensitic stainless sales in 1984, JFE has further developed with the expertise in the corrosion research the martensitic CRA materials, from modified 13CR (named JFE-HP2-13CR) up to 15CR-17CR (named JFE-UHP™-15CR and JFE-UHP™-17CR) and supplied to the operators of oil & gas industry with great satisfaction.

JFE'S PREMIUM CONNECTION

JFE's connection development started in early 1980s. In the 1990s, JFE introduced the JFEBEAR™. More recently, in 2011, the JFELION™ connections were developed, designed to meet today's toughest well conditions and industry testing protocols. These JFE's flagship connections have been globally supplied over 400,000mt and 100,000mt, respectively, with satisfaction. In 2018, JFE have established the connection testing laboratory at JFE Connections America (JCA) to further accelerate the connection development and evaluation.

APPLICATIONS OF CRA TUBING AND CONNECTION TO CO₂ UNDERGROUND STORAGE WELLS

With the growing global demand and necessity for carbon reduction, JFE sets great priority on the supplying of tubing and connection for the CO₂ underground storage wells.

In general, CO₂ accelerate the corrosion of injection tubing material because the CO₂ decreases the pH of water. If other corrosive impurities such as SO₂, NO₂ and O₂ are included in the CO₂, severity to the CO₂ tubing will be increased further.

JFE has evaluated their martensitic CRA grades including JFE-UHP™-15CR and JFE-UHP™-17CR tubing where they have shown great CO₂ resistant corrosion performance against certain CCS simulated environments. Some of the evaluation results were published in the technical paper¹⁾ for AMPP Annual Conference (former NACE International's CORROSION Conference & Expo), and will be presented in the Eurocorr 2023 (The Annual Congress of The European Federation of Corrosion) as well.

JFE has also evaluated the sealability performance on their robust JFELION™ connection simulating worst case thermal shock during CCS operations. JFELION™

showed seal performance even after temperature cycles between -35C/ambient temperature and rapid cooling with a temperature drop of 80 degrees Celsius.

JFE has been involved intensely in the material selection discussion and supply of the tubing for CCS projects. Starting from 2008, JFE has supplied the CRA tubing with their premium connections to several CCS projects globally as shown below in Table 1.

JFE would continue to put weight on the investigation studies to establish further confidence in different impurity and water chloride levels depending on the CO₂ source/well environment. JFE is collaborating and discussing with the operators/industry for optimization and supply of the CRA tubing for future CCS projects, enhancing the worldwide storage capacity.

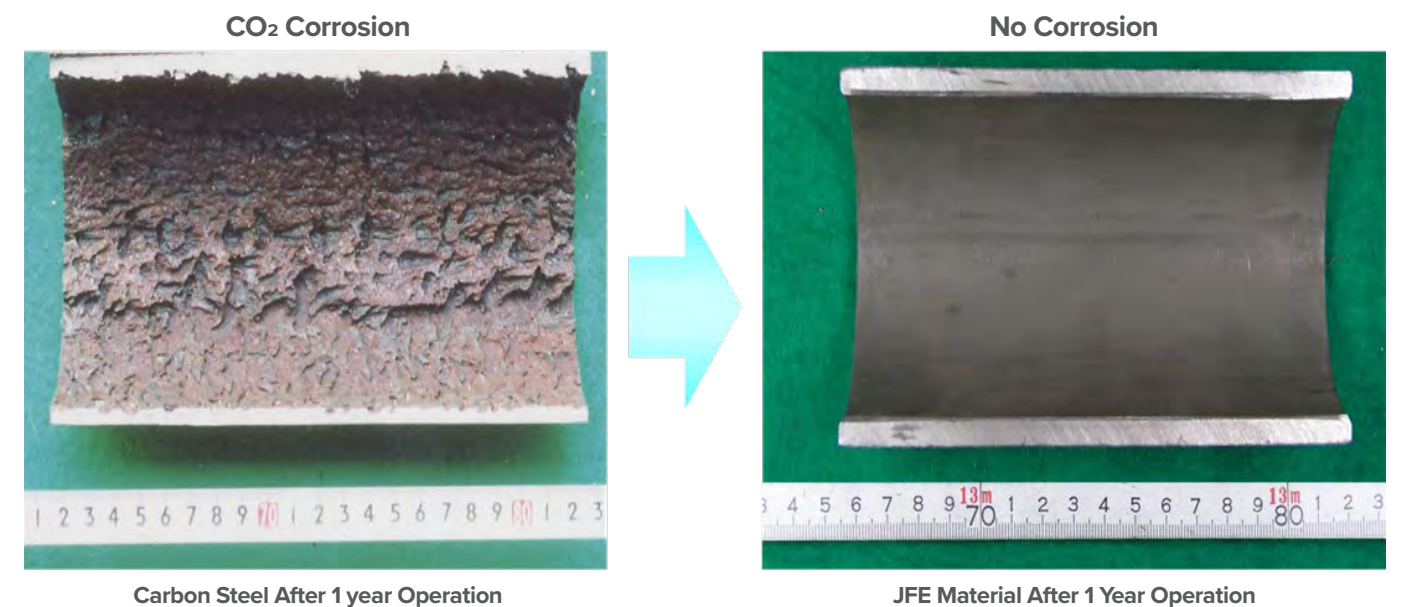

Figure 1: Example of CO₂ Corrosion



Figure 2: Image of JFE-UHP™-15CR and JFE-UHP™-17CR

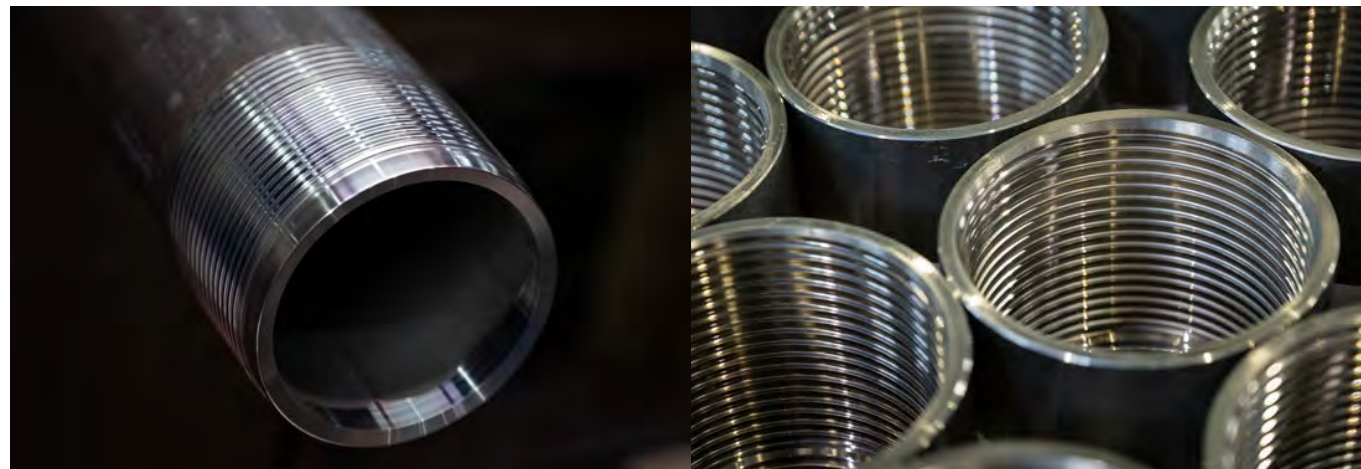

Figure 3: Image of JFE Premium Connection (JFEBEAR™, JFELION™)



Figure 4: JFEBEAR™, JFELION™ company logos

| YEAR | AREA | MATERIAL GRADE | OD (INCH) | WT (POUNDS/ FEET) | CONNECTION | PROJECT TYPE |
|------|------------|----------------|------------------|-------------------|------------|-------------------------------|
| 2008 | N. America | HP2-13Cr-95 | 7 | 29 | JFEBEAR | Commercial |
| 2009 | N. America | HP2-13Cr-95 | 4.5 | 18.9 | JFEBEAR | Commercial |
| 2008 | N. America | 13Cr-80 | 9.625 | 47 | JFEBEAR | Commercial |
| 2009 | N. America | 13Cr-85 | 4.5 | 12.6 | JFEBEAR | Commercial |
| 2009 | Oceania | L80-13Cr | 5.5 | 17 | JFEBEAR | Pilot |
| 2014 | Japan | L80-13Cr | 3.5 | 12.7 | JFEBEAR | Pilot |
| 2014 | Japan | HP2-13Cr-110 | 3.5 | 12.7 | JFEBEAR | Pilot |
| 2022 | Oceania | HP2-13Cr-95M | 3.5 | 9.2 | JFEBEAR | Commercial |
| 2022 | Oceania | L80-13Cr | 4.5 | 13.5 | JFEBEAR | Pilot |
| 2022 | N. America | L80 | 9.5 | 47/53.5 | API 5B | Pilot |
| 2022 | Europe | UHP17Cr-110 | 7 | 29 | JFELION | Commercial |
| 2023 | Japan | HP1-13Cr-110 | OD:2.375" ~ 7" | | JFEBEAR | Pilot |
| 2023 | N. America | L80-13Cr etc. | OD:2.875" ~ 5.5" | | JFEBEAR | Pilot |
| 2024 | Asia | HP1-13Cr-110 | 7 | 29 | JFELION | Pilot |
| 2024 | Asia | UHP17Cr-110 | 7 | 29 | JFELION | Commercial (Under discussion) |

Table 1: JFE's Steel Pipe Supply Record for CO₂ Injection. (Include Projects Under Discussion)

REFERENCE

1. Yuichi Kamo, Kenichiro Eguchi and Hiroyuki Takai, "Corrosion Behavior of Martensite-Based Stainless Steels in Chloride Solutions Saturated with CO₂ Containing Impurity Gases," AMPP Annual Conference 2023, paper No. 18908 (Denver, Colorado,2023)



YOUR BEST LOW COST SOLUTION FOR BEATING THE HIGH COST OF CORROSION AND EXTENDING THE LIFE OF YOUR TUBULARS!

DUOLINE 20® FIBERGLASS (GRE) LINED TUBING IN CO₂ INJECTION AND SEQUESTRATION MAXTUBE

SUMMARY

As CCUS projects are driven by the common goal of reducing global carbon emissions, the technologies employed in these projects have a critical role to play in achieving this goal. In several cases, existing ageing infrastructure from oil or gas field projects is repurposed for injecting CO₂ for up to five more decades. Maxtube provides a technology that contributes to increasing the longevity of the asset while reducing the cost and overall carbon footprint of the project.

Maxtube Limited are the proud owners of Duoline Technologies in the United States. Duoline are the pioneers of Fiberglass (GRE) Internal Lining systems, used to prevent corrosion in downhole tubulars. Over 110 million feet of Duoline GRE lined tubing has been installed in over 55,000 wells worldwide.

BENEFITS

There are two distinct contributions that Duoline 20 GRE lined tubing can make to reducing the carbon footprint of a CCUS project.

- Firstly, Duoline 20 GRE lining provides a corrosion barrier which protects carbon steel tubing for decades. The combined system costs a fraction of chrome and higher alloy steel tubing. Additionally, unlike sensitive alloy steels, Duoline GRE liners will offer consistent corrosion protection irrespective of contaminants in the flue gases from different industrial sources over the life of the project.
- Secondly, eliminating the use of chemicals for corrosion inhibition means eliminating carbon emissions from chemical manufacture, transportation, and injection into the wells over the life of the well.

The above benefits of applying Duoline 20 GRE Lined tubing in CCUS applications enable significant reductions in CAPEX and OPEX over the lifecycle of the wells. This in turn enhances the overall viability of the project.

DESCRIPTION

WHAT IS DUOLINE 20 GRE LINED TUBING?

Duoline 20 is a Glass Reinforced Epoxy (GRE) composite liner, which is inserted inside steel tubing to protect it from corrosion due to CO₂, free O₂, H₂S, chlorides, water, and other constituents which may exist in the process fluids. This tubing is used downhole in injection and production wells. Duoline GRE also mitigates solid deposition inside the tubing.

Tubing made Carbon steel, lined with Duoline 20 GRE, can be utilized instead of expensive chrome and higher alloy steel grades, which are often the appropriate material for resistance to CO₂.

Duoline 20 GRE Lined tubulars have been successfully employed in a variety of applications where they have been exposed to extreme process conditions – high temperatures, high pressures, high concentrations of dissolved gases, high chlorides, and high flow rates as well as mechanical “stresses” during multiple downhole interventions. The success of the technology is based on extensive testing and trials conducted by operators worldwide over five decades.

Duoline GRE liners are a proven flow assurance enabler. Benefits derived from the properties of the system include elimination of solid deposition, higher flow rates, reduced frictional losses and higher fluid temperature retention. These are attributed to the smoother surface of the Duoline GRE compared to steel, as well as the added insulation provided by the layers of grout and GRE. Enhanced flow assurance allows a more consistent, uninterrupted injectivity rate.

Duoline GRE has been proven to withstand:

- Temperatures from -51 °C (-60 °F) to 144 °C (291°F)
- More than 300,000 ppm chlorides
- 100% wet, dry and dense phase CO₂
- Over 18,000 psi pressure

Duoline 20 has been a workhorse in CO₂ injection wells since 1984. This track record provides significant experience for knowledge transfer into material selection for carbon injection and utilization downhole in global CCUS projects.



DESCRIPTION

The Duoline 20 Lining system consists of a fiberglass reinforced epoxy resin composite liner cemented inside low alloy carbon steel tubing. The cement transfers fluid pressure to the steel. The ends of the liner are protected from mechanical damage by end caps called flares. A polymeric Corrosion Barrier Ring extends the corrosion barrier across the coupling between two adjacent flares.

DUOLINE 20 GRE LINED TUBING IN CO₂ INJECTION

The first miscible CO₂ Injection EOR project in Canada began in 1984 in the Joffre Viking Tertiary Oil Unit by Vikor Resources and the Alberta Oil Sands Technology and Research Authority. This is the first known successful application of fibreglass-lined tubing to combat CO₂ corrosion.

Since then, Duoline 20 has been used extensively by Equinor, ExxonMobil and Oxy in CO₂ injection wells. In the United States, nearly 20 million feet of Duoline GRE Lined tubing has been used in CO₂ injection wells. In 1996, Statoil were among the first to use Duoline GRE Lined Tubing in offshore Water Alternating CO₂ (WAG) wells.

Duoline 20 has since become the gold standard for tubing material in CO₂ injection wells, CO₂ WAG wells, carbonated water injection wells and hydrocarbon producers with high CO₂ concentrations. Duoline GRE has been tested and field-proven to withstand dense phase CO₂ (wet and dry) and low pH solutions from dissolved CO₂, for decades.

Duoline 20 GRE lined tubing offers attractive savings compared to capital intensive high-chrome materials that are often the metallic selection for CO₂ applications.

CCUS projects depend on dehydration of the CO₂ gas to prevent corrosion. It is undoubtedly challenging to maintain the 100% absence of moisture downhole. The impact of residual water from the reservoir during shut-in of CO₂ injection wells is also a concern. In such cases, the dehydration of the gas will prove ineffective in combatting corrosion downhole. This risk necessitates a pre-emptive corrosion prevention strategy.

Over the life of CCUS projects, it is expected that the injected gas may be contaminated with NOx, SOx and other contaminants from flue gases generated at various industrial sources. The performance of metallic alternatives is sensitive to variations in the composition of process fluids. Duoline GRE liners, on the other hand, will offer consistent corrosion resistance irrespective of variations in constituents over the life of the project.

The selection of Duoline GRE lined tubing provides added insurance against potential process interruptions on the surface. Any disruption to surface facilities for dehydration or treatment of the injected gas will not interrupt CO₂ injection if the material used downhole is able to withstand all corrosive elements. It is also noteworthy that repairs due to avoidable downhole failures are far costlier and time-consuming than repairs on the surface. Such cases justify the added insurance of Duoline GRE lining of tubing.

The above points demonstrate how Duoline GRE enhances the integrity and flow assurance of CO₂ injection systems thereby reducing the overall carbon footprint of the project. Duoline GRE Lined tubing offers substantial value to the overall economic and environmental viability of CCUS projects. Whether the well is completed onshore or offshore, platform or subsea, Duoline GRE lining is a single solution for tubing corrosion prevention and flow assurance.

INDUSTRY AND REGULATORY AUTHORITY ENDORSEMENTS

Duoline GRE liners have been tested extensively for resistance to exposure to a variety of industry chemicals, full-scale combined loading inside tubing, pressure cycling, high erosional velocities, fatigue, and durability when exposed to downhole, coiled tubing and wireline, interventions.

Saudi Aramco, Shell, BP, Eni, and Statoil have conducted tests to confirm the viability of Duoline 20 GRE lined tubing as an alternative to chrome alloy steels.



Eni performed qualification tests on Duoline 20 GRE Lined tubing for high-velocity gas production. These include tests to confirm the erosion resistance and mechanical properties of Duoline GRE which proved that its fatigue resistance is about nine times higher than super-duplex stainless steel. Direct impact and straight pipe test results showed a very good resistance of Duoline GRE comparable to that of a Nickel Alloy 625 sample under similar conditions.

BP performed comprehensive testing to demonstrate the fatigue resistance of the system. Duoline GRE lined assemblies were internally pressurized to 8,000 psi and exposed to one million load cycles. They were also subjected to ISO 13679 loading in the first quadrant. None of the assemblies showed any leaks or signs of damage to the GRE liner and the components in the connection area.

Duoline GRE has been used in wells with temperatures up to 145 °C (293 °F) and has also been tested for resistance to temperatures as low as -51 °C (-60 °F). The resistance of Duoline GRE to temperature swings is particularly relevant considering the phase change sensitivity of CO₂ relative to temperature and pressure. Additional testing is planned to confirm the integrity of the system when exposed to uncontrolled flash freezing due to rapid pressure drop.

Operators have tested the compatibility of the Duoline 20 GRE Lining System with several premium connections. These confirm that the Duoline's GRE lining process and system components do not affect the connection dimensions, torque values and gas sealability. Duoline 20 GRE Lining systems have been applied on premium connection tubing from Tenaris, Vallourec, JFE, and Voest Alpine, among others.

In the US, experience and good practices recorded in the field of CO₂ injection are documented as regulatory alternatives and operating practices for the geological sequestration of CO₂ by the United States' Environmental Protection Agency (USEPA). Federal Requirements under the Underground Injection Control (UIC) Program for CO₂ sequestration wells, are codified in the US Code of Federal Regulations, known as the Geologic Sequestration Rule, which establishes a new class of injection well (Class VI) and sets minimum technical criteria and well construction guidelines for these wells for the purpose of protecting underground sources of drinking water (USDWs). This guidance describes the construction requirements for an approved Class VI injection well wherein GRE lined tubing is well accounted for.

VALUE ADDITION FROM FLOW ASSURANCE BENEFITS

Duoline GRE retains its surface smoothness over its life which retards, and even eliminates, the nucleation and subsequent deposition of solids such as scales, paraffins and hydrates on its surface hence enhancing flow assurance in wells.

Flow assurance benefits derived from Duoline 20 GRE Lining have also been attributed to the thermal insulation provided to the steel by the fiberglass and grout. Eni and Pertamina have published findings of higher temperature retention in wells with Duoline GRE lined tubing compared to bare steel tubing.

For higher thermal insulation requirements, Duoline can engineer a lining solution compatible with Vacuum Insulated Tubing (VIT) to combine superior corrosion resistance with superlative thermal insulation.

Duoline GRE lining system has also been applied to flowlines. Eni, Shell, and Apache subsidiaries have been using Duoline GRE lined tubing to construct flowlines used for the transportation of oil and water. In a worldwide first, Shell constructed a high-pressure flowline network using premium connection tubing. In such a system, the combination of the metal-to-metal seal in the premium connection tubing, and the Duoline GRE backed by the steel body of the pipe, ensure that there is no permeation of dissolved gases through the flowline into the atmosphere.



STORAGE



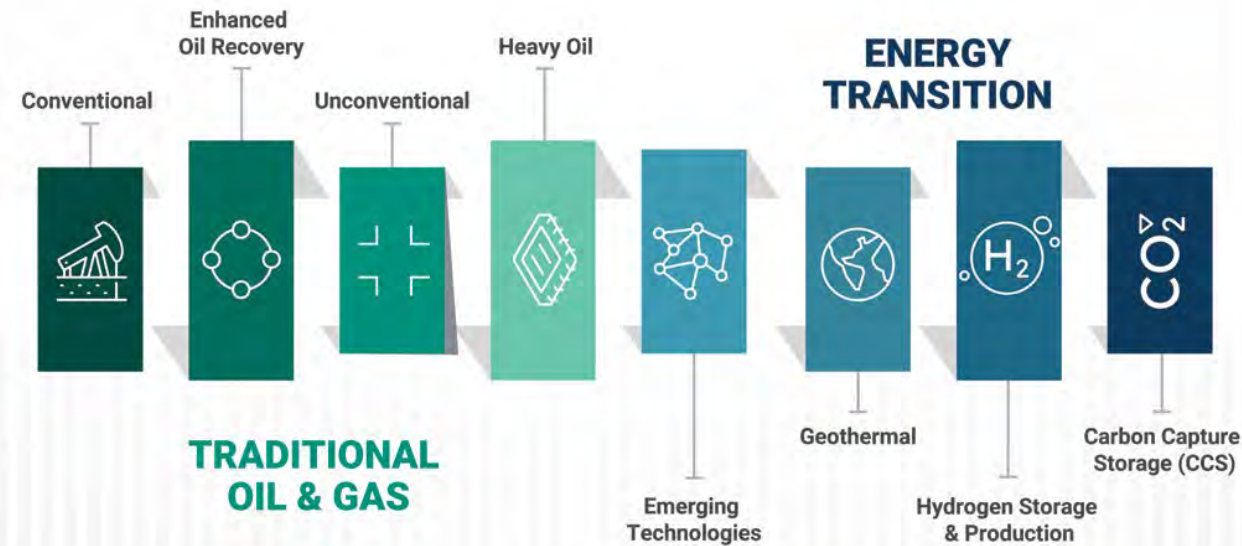

INNOVATORS IN SIMULATION TECHNOLOGY

CMG

SUMMARY

Computer Modelling Group Ltd. (CMG) (TSX: CMG) is a global software and consulting company that combines science and technology with deep industry expertise to solve complex subsurface and surface challenges for the new energy industry around the world. For over 45 years, we have helped organizations unlock value from their assets through continuous innovation and consultation. Our expertise spreads across a broad spectrum of energy workflows, and our technology can help energy companies navigate this complex and changing landscape. CMG is headquartered in Calgary, AB, with offices in Houston, London, Dubai, Bogota, Bengaluru, and Kuala Lumpur.

BENEFITS

- De-risk a range of Energy Transition projects related to CO₂ storage; H₂ storage and production; and geothermal processes
- Analyse the subsurface uncertainties associated with injection and storage of CO₂
- Quantify the storage volumes; long term stability; and applicable injection rates for CO₂ storage projects
- Satisfy regulatory requirements through determining the long-term safe containment of CO₂

INNOVATION TO ADVANCE A NEW ENERGY SYSTEM

Longer forecasting timescales, limited subsurface data, and public safety and environmental concerns increase the complexity of carbon storage projects exponentially. CMG's 20 years of experience in helping energy companies use CO₂ injection to enhance oil recovery can be applied to accelerate the transition safely and effectively to a low-carbon future. Our knowledge and real-world experience allow us to help companies in oil and gas and other carbon-intensive industries like refining, power generation, and manufacturing make the transition.

DESCRIPTION

CMG has been involved in subsurface modeling of the application of CO₂ in the enhanced oil production since the late 1980's centered around our GEM reservoir simulator. Following the Kyoto Protocol in 1998 a change in focus resulted in the forming of a research consortium between Research Institute of Innovative Technology for the Earth (RITE) and Japan Oil Engineering and CMG to enhance GEM to produce the required capabilities allowing predictive modeling of the CO₂ storage process in deep saline aquifers.

Further investigations and extensions of the modeling environment at this time also led to the investigation of CO₂ injection into coal seams. This process provided two main benefits: The potential increase in methane production due to preferential replacement of the CH₄ by CO₂ on the coal surface; as well as the long-term storage of CO₂ as it adhered to the coal surface.

As the safety and liability frameworks were gradually created, understanding the ability to safely store CO₂ underground; the ability to contain the CO₂ over extended periods of hundreds or even thousands of years; and the type of physical mechanisms that take place over both the short- and long-term storage, were crucial to moving the concept of aquifer storage forward. CMG's GEM reservoir simulator, originally designed for oil and gas extraction modeling, was enhanced to provide the physical mechanisms required to simulate CO₂ behavior in underground formations. This involved:

- Detailed CO₂ solubility calculations for the subsurface fluids; as well as molecular dispersion and diffusion models
- Geochemical modeling to capture the geochemical interactions between the injected CO₂; the reservoir fluids; and the minerals present in the aquifer rock.
- Geomechanical analysis of the stresses induced to determine seal integrity and fault movement; reactivation of inactive faults leading to undesired flow and leakage.
- Temperature effect on fluid movement, geochemical reactions, and geomechanical response.
- Coupling to surface facilities

CMG's CoFlow solution is an Integrated Reservoir & Production System Modelling software that allows detailed analysis of the well and pipeline systems feeding CO₂ into the subsurface, modelling steady state flow in the pipeline system. CoFlow's multi-fidelity, multi-disciplinary, collaborative modeling environment, allows reservoir and

production engineers to make informed decisions on large integrated oil and gas projects and is fully integrated with GEM to provide an end-to-end software solution to model CO₂ transport and storage.

For over 45 years, CMG has brought industry-first technologies to the market through extensive research and collaboration. In our recent collaboration, CMG joined hands with Kongsberg to form a research consortium with 10 other oil and gas industry partners to investigate CO₂ storage in depleted oil and gas systems. This consortium has resulted in software that links Kongsberg's LedaFlow transient pipe and well modeling product with CMG's GEM reservoir simulator to accurately capture the CO₂ behavior during transport and storage, focusing on the ability to start up and shut down injection operations safely and effectively.

Further enhancements of CMG's GEM simulator have also been developed over the years to allow for the additional complications of storage in the low pressure (and lower temperature) depleted oil and gas reservoirs

1. Pure CO₂ behavior as well as impure mixtures, and the mixing with existing reservoir hydrocarbons.
2. Rapid cooling to subzero temperatures around the injection wells and the consequences of such temperature changes to the local well environment and ability to inject.

More recently, with the latest software development of Focus CCS, customers have access to a solution that supports their process from end-to-end, fast-tracks their time-to-value, and allows them to make business critical decisions regarding new CCS ventures, through faster and more efficient model creation, and automated regulatory reporting.

CMG's commitment to bringing industry-first solutions to market, coupled with high-quality user experience and expert customer support has always set us apart from the competition. CMG's dedicated support team is comprised of practicing reservoir simulation engineers who will answer your questions, assist with installation and resolve technical issues to keep your business running smoothly. Our team of experienced and skilled professionals guide users through an immersive online or in-person learning process that builds capabilities that can be directly applied to real-world projects. Customer Success and Consulting experts average at least 10 years of engineering experience and offer over 30 courses that cover all recovery processes and reservoir challenges, with dedicated training facilities and global support.

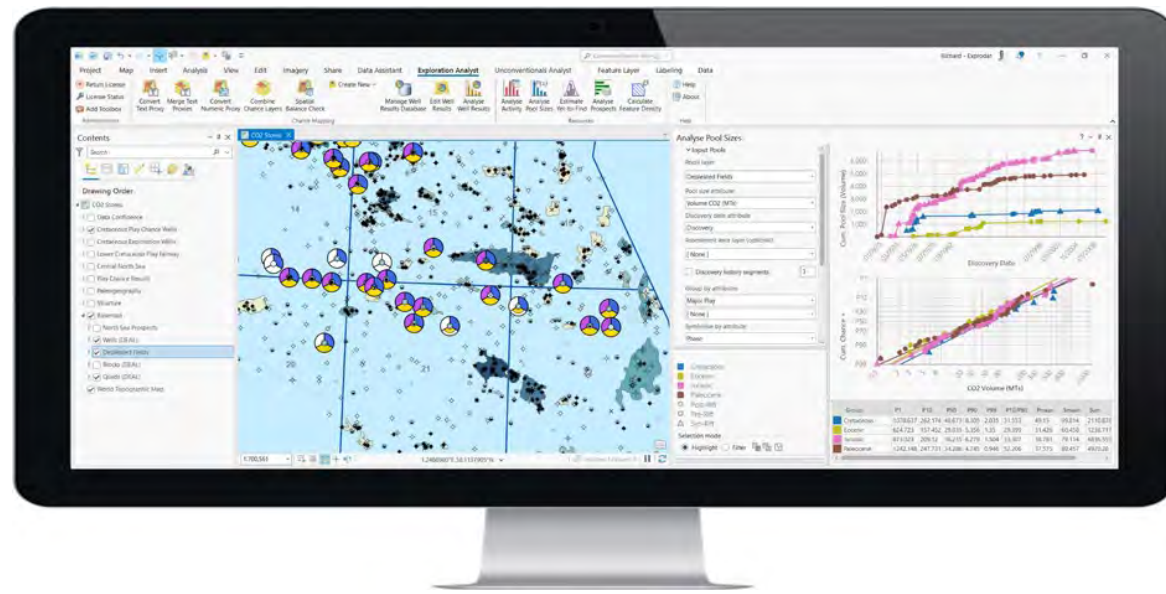

EXPLORATION ANALYST TO MAP AND EVALUATE STORAGE PLAY POTENTIAL GETECH

SUMMARY

Exploration Analyst is an extension to Esri's ArcMap and ArcGIS Pro software that assesses potential storage capacity, maps storage segments with common risk profiles, and high-grades storage areas with the best Chance of Success (COS). Exploration Analyst can validate COS maps against well results, calculate prospect volumetrics, perform multi-criteria block or lease analyses, as well as evaluate competitor positions and support portfolio strategy. Exploration Analyst creates individual

COS layers for separate geological elements that contribute to successful storage, including reservoir, trap, and seal factors. Layers can be constructed from data or sketched from concepts, and are then combined into a geologic play-chance model. Additional environmental, regulatory, infrastructure, or other elements can be added to the analysis as required. Exploration Analyst provides a wide range of summary maps, graphs, and reports to quickly and intuitively communicate results.

BENEFITS

- Agnostic compilation of proprietary, vendor, and public data.
- Efficient integration of inputs from multiple disciplines that facilitates communication among diverse team members.
- Auditable conclusions that can be validated against well results.
- Volumetrics and risk evaluated in a single application.
- Inputs may be rigorously derived from data, loosely sketched from concepts, or anything in between.
- Workflows can be standardised and shared using Tasks, as well as run in batch using Exploration Analyst's geoprocessing tools.

DESCRIPTION

Exploration Analyst is a straightforward Common Risk Segment mapping tool based in ESRI's ArcMap or ArcPro that convolves any combination of geologic, environmental, regulatory, infrastructure, or other geospatial inputs to calculate storage volumetrics and Chance of Success on a map basis. Because Exploration Analyst has an easy-to-master user interface and standard ESRI data structures

it can be easily adopted and integrated into existing or evolving workflows. Exploration Analyst workflows can be standardized and shared and even run in batch. The concepts and functionality have been honed by decades of deployment in the hydrocarbon industry, with clear translation to carbon storage application.

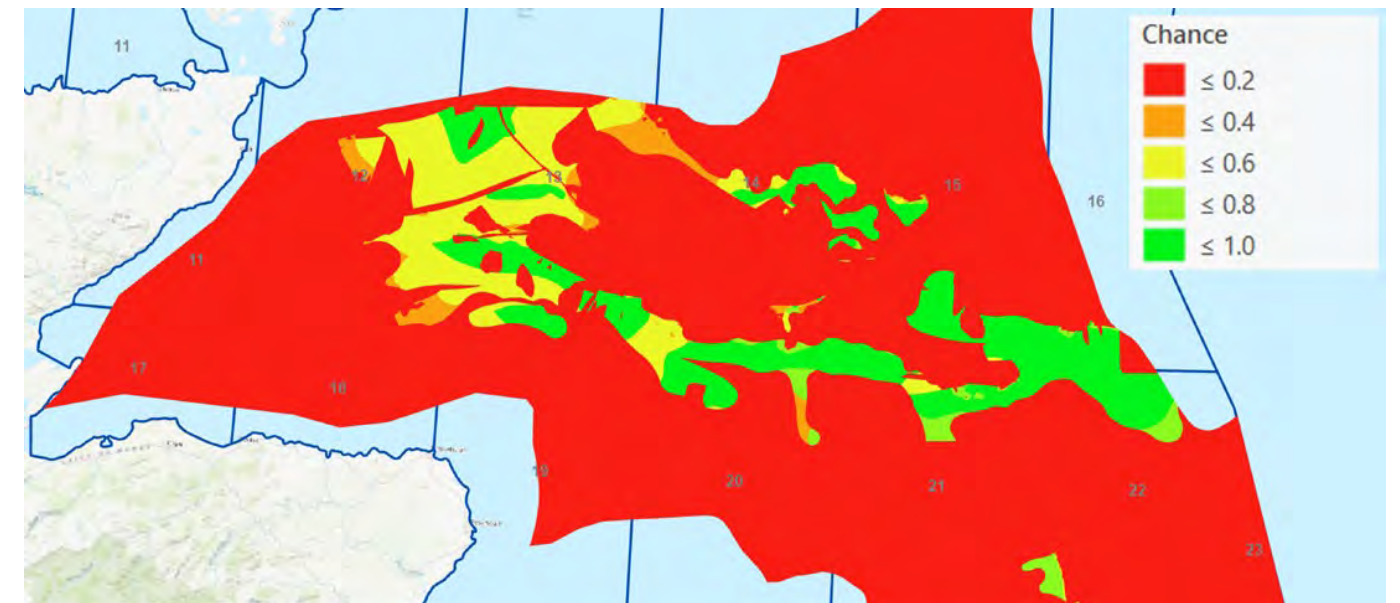

Regional integrated Chance of Success

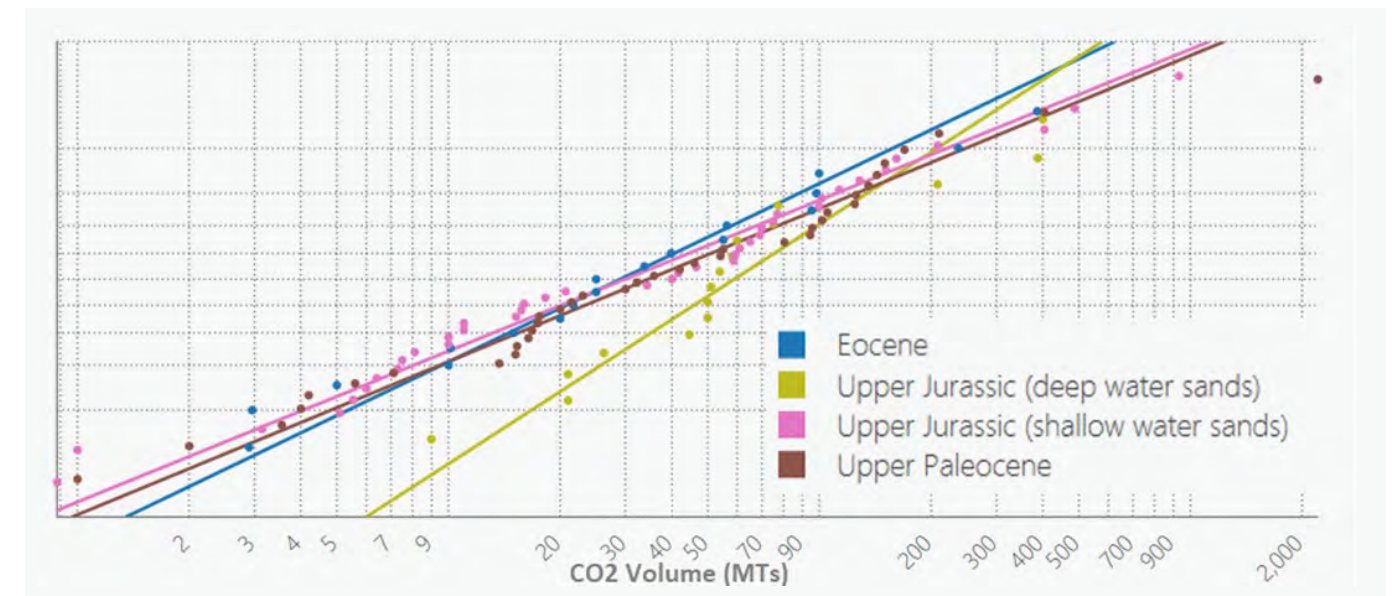

Risked storage capacity, by stratigraphic unit

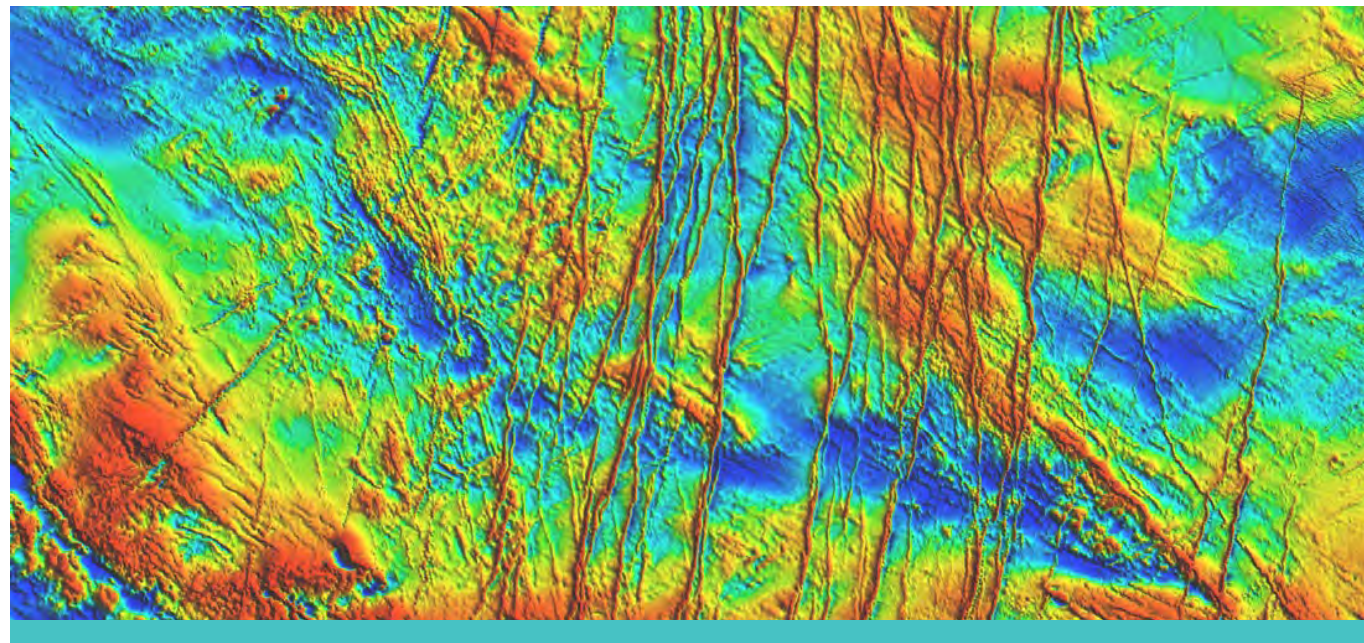

REGIONAL FAULT MAPPING TO EVALUATE SEAL INTEGRITY AND INDUCED SEISMICITY RISK GETECH

SUMMARY

Getech regional (10^2 - 10^5 km²) fault mapping starts with the world's most comprehensive and quality-controlled gravity and magnetics database, applies advanced processing (including high-pass filtering, total horizontal derivative, and tilt angle), creates robust 2D, 2.5D, and 3D inversions, and picks potential faults using Automated Coherent Lineament Analysis and Selection (ACLAS), a process developed and published by Getech. Additional client geophysical data can be integrated to enhance the analysis, but is not required. Potential faults are iteratively validated and

classified into temporal and kinematic families using available topographic, remote-sensing, and geologic (including seismic) data and Getech's plate-tectonic models. Fault azimuths are compared to regional stress measurements to evaluate the chance for fault segments to be under extension or compression. The regional fault framework can be used on its own or serve as the basis for more detailed local interpretation, including planning seismic-monitoring networks or 3D seismic acquisition.

BENEFITS

- Can be applied anywhere, even where seismic or well data are sparse.
- Existing Getech database, especially good in US Lower 48 onshore and shallow water, allows immediate project initiation without additional geophysical data acquisition.
- Total project time from kick-off to final delivery can be weeks instead of months or years.
- Existing Getech datasets are regionally consistent, they do not require compilation and QC of diverse legacy data, for example seismic surveys of varying vintage, quality and acquisition/processing parameters.
- Proven approach has been validated over many years in hydrocarbon and geothermal applications worldwide.

DESCRIPTION

Getech prepares detailed regional (10^2 - 10^5 km²) fault maps to support client evaluation of seal integrity and the potential for induced seismicity, as well as to guide additional, more detailed, investigations including the design of seismic monitoring networks and the acquisition of project specific 3D seismic surveys. The process begins with an inventory of existing Getech and client geophysical data, including gravity, magnetic, and seismic. The data are integrated and processed with advanced techniques including filtering, reduction to pole, and various derivatives appropriate to the specific local question addressed by the investigation. Getech (alone, or in collaboration with the client) synthesizes and evaluates available literature and other publicly available geoscience data against Getech global plate-tectonic models to establish a fundamental tectonic framework. Faults are interpreted from the processed geophysical data by human and machine methods, including by Automated Coherent Lineament Analysis and Selection (ACLAS, Cascone et al. 2017, *Geophysics*, v. 82. P. G87-G100, <https://doi.org/10.1190/geo2016-03371>), and iteratively compared to topographic, remote-sensing, and geologic data to describe each fault according to its relative importance for compromising seals or inducing seismicity, and according to its kinematics. Individual faults are grouped into families of structures that share kinematic and activation histories. Fault-segment azimuths are compared to publicly-available regional stress orientations (\pm client local measurements, for example from image or caliper logs) to evaluate slip propensity. Fault interpretations are iteratively combined with 2D, 2.5D, and 3D inversion of gravity and magnetic data to sharpen the interpretation of subsurface lithologic geometry, including depth to significant boundaries, for example crystalline basement or clastic/carbonate transitions. The 2.5D modelling also investigates lithologic variations within constrained geologic units via density (gravity) or susceptibility (magnetic) variation. Results are delivered in industry-standard, fully attributed, electronic files for a wide range of analytic platforms (for example ESRI ArcGIS, QGIS, Petrel, KINGDOM, Geographix, CPS3, IESX, SEG-Y, SPS, UKOOA, OGP, Landmark, ZMap and OpenWorks).

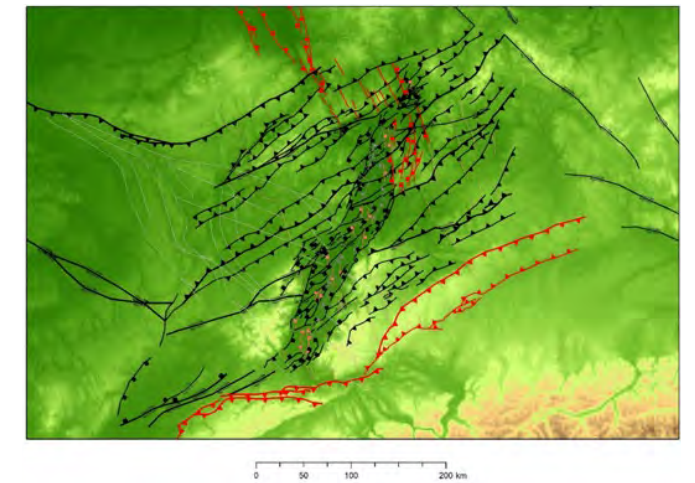

Regional fault mapping symbolized by crustal scale and kinematics

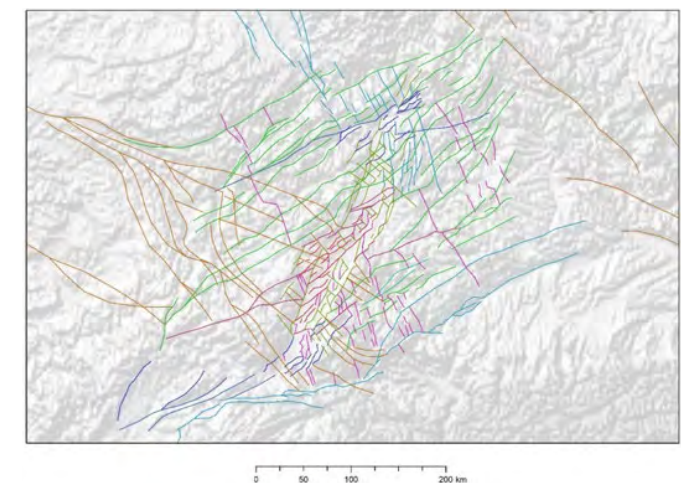

Regional fault mapping symbolized by activation history

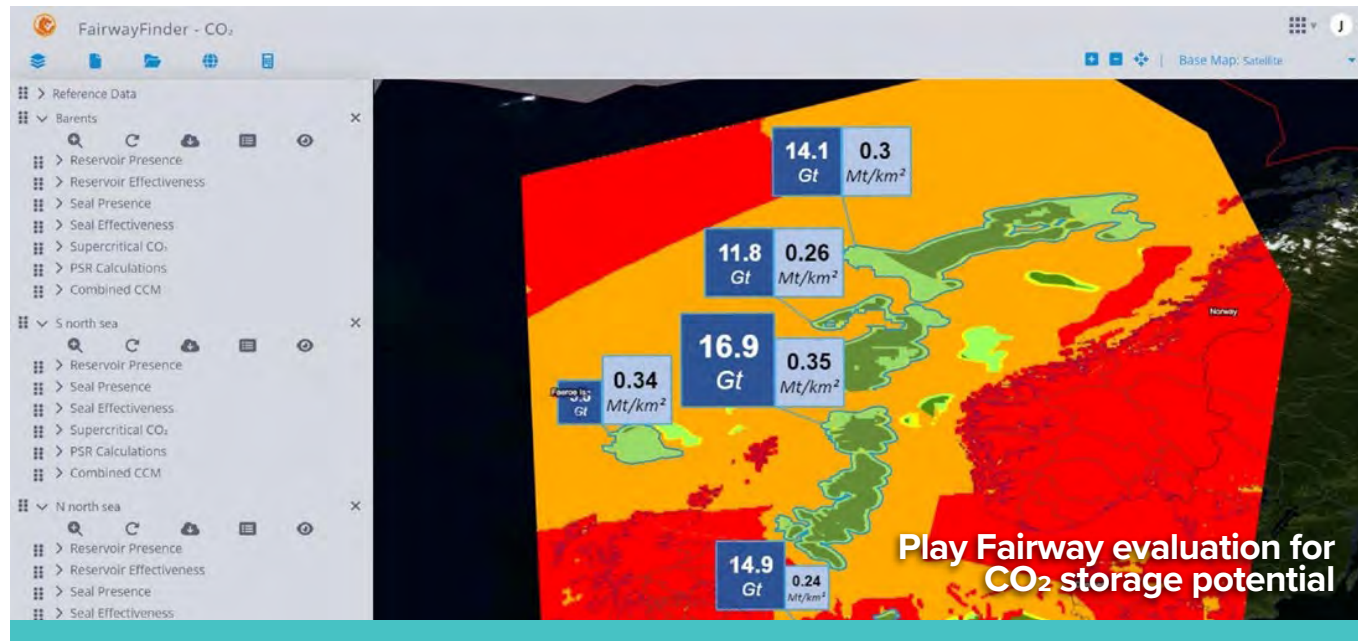

CO₂ STORAGE SCREEN HALLIBURTON

SUMMARY

Screening, leading to site selection, is the first stage of the carbon sequestration workflow. This involves identifying stratigraphic units with storage potential and identifying locations with the greatest prospectivity. DecisionSpace® 365 CO₂ Storage Screen builds on over 20 years of subsurface insights to provide users with the subsurface context to rapidly screen sequestration targets around the world. Our screening inputs are derived from disparate, often siloed, publicly available data, combined with

global subsurface models and geoscience principles, to extrapolate into white space and provide insight into data lean saline aquifers. Different stratigraphic units can be rapidly and uniformly assessed to test multiple scenarios or compare multiple fairways within the cloud hosted screening application. Storage volume calculations and risk assessments are collated in storage atlases to provide users with the understanding required to select potential storage intervals from an existing portfolio.

BENEFITS

- **Answer in minutes** – Reduce the time required to generate a play fairway evaluation for CO₂ storage potential from weeks to minutes, with comprehensive analysis, evaluation of multiple concepts and Prospective Storage Resource Calculation
- **Any play, anywhere** - Model driven interpretive inputs allow global usage regardless of data coverage or exploration history
- **Proceed with confidence** – Identify suitable saline aquifers for CO₂ storage with Neftex® Predictions unique integration
 - **Consistent analysis** – Inputs supported by the Neftex® Predictions global tectono-stratigraphic framework deliver a consistent analysis regardless of differences in geography or stratigraphy
 - **Integrated assessment** – Assess both the geographic and temporal distribution of play elements and risks related to reservoir, seal, supercriticality, or operations
- **Connected workflows** – Bring screened outputs into geospatial software or DecisionSpace® 365 applications
- **Quickly tap into an area** – Regional storage atlases provide immediate overviews
- **Portfolio risk and ranking**

DESCRIPTION

One of the initial challenges facing the global development of Carbon Capture and Storage (CCS) is the identification and characterization of subsurface storage sites. While depleted oil and gas fields represent some of the best understood and commercially viable targets, there is simply not enough storage volume to tackle the scale of the challenge. Saline formations are porous and permeable reservoir horizons that contain saline fluid as opposed to hydrocarbons and have a much larger storage potential.

Fortunately, the concept of exploring for suitable saline formations shares many similarities with play-based exploration for hydrocarbon reservoirs. As part of the energy transition effort, our geoscientists have been focused on adapting traditional oil and gas workflows, gathering datasets, and investigating stratigraphy to help with CO₂ storage identification. These workflows are underpinned by data and a global tectonostratigraphic model, combined with geoscience principles to enable a consistent global coverage of inputs for fairway analysis. Workflow results are collated together in storage atlases that provide immediate overviews of the storage potential and risks associated with assessed intervals. This enables a user to quickly familiarise themselves with the breadth of stratigraphic potential in a target area.

The consistent, reproducible screening workflows on CO₂ Storage Screen, provide teams with an accelerated understanding of the subsurface and helps identify suitable saline aquifers for CO₂ storage. The efficiency gains of cloud technology and leveraging a wealth of subsurface context, means that within minutes users can test storage concepts, investigate risks, and make informed decisions without significant investments of time and resources. The underpinning Neftex® Predictions context supports those without location specific subsurface understanding. In addition, comparing fairways via Prospective Storage Resource Calculation (PSR) provides initial ranking of play potential, allowing a user to quickly build a custom portfolio of storage targets anywhere around the world.

For users who wish to understand the deeper context, including the search for analogues or access to stratigraphy, tectonic or climate frameworks, a full subscription to Neftex® Predictions is recommended. This access will help the user gain a deeper understanding with the Neftex® interpretative framework and the wealth of conditioned and contextualised subsurface data.

For more information on how DecisionSpace® 365 CO₂ Storage Screen or a comprehensive Neftex® subscription can meet the challenge of screening for suitable storage locations, please contact us.

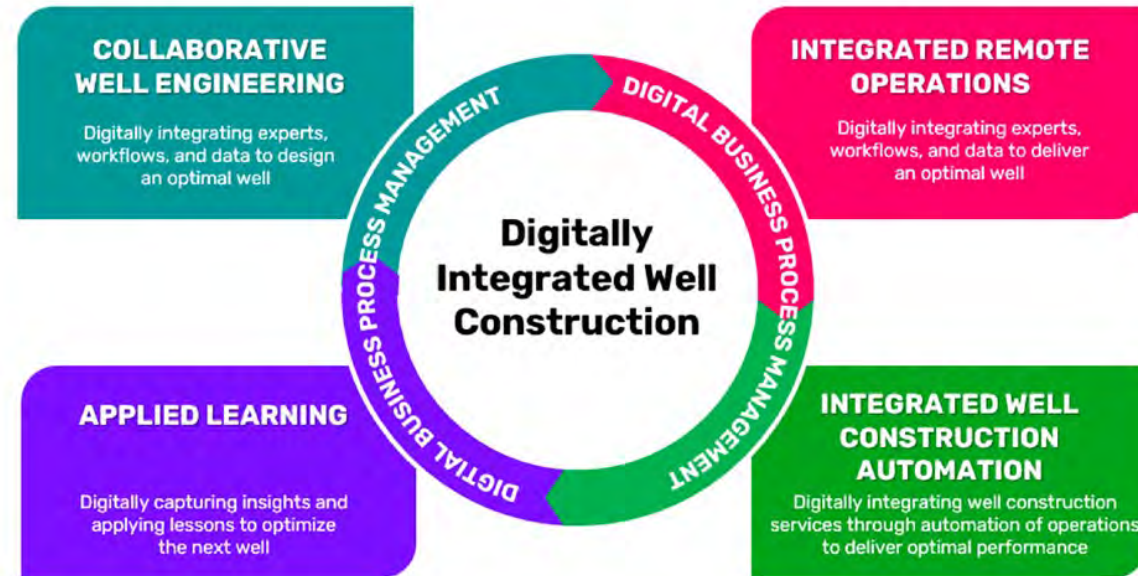

CO₂ STORAGE WELL CONSTRUCTION & INJECTIVITY TECHNOLOGY

HALLIBURTON

SUMMARY

Digitally Integrated Well Construction is Halliburton's approach to plan, design, and execute a well using Collaborative Well Engineering and Integrated Automation. As part of this approach, the Digital Well Program® (DWP) web based application integrates offset-well analysis with industry-proven engineering algorithms, and reporting tools to fast-track a cost-effective well program approval process and well delivery, while supporting continuous improvement of well design. Implementation of a DWP solution can help address most concerns including, reduce

well program preparation time, increase well reliability, accelerate end-to-end well delivery, while lowering cost.

CO₂ injection modelling requires dedicated wellbore simulations to ensure operations are planned within safe and effective limits. NETool™ software is a steady-state numerical simulator that provides user-friendly comprehensive modelling with the capabilities required for a simple vertical well, a long horizontal well, or a multilateral well with complex completions.

BENEFITS

Digital Well Program® outcomes:

- Improved decision-making on drilling parameters using comprehensive and proven engineering
- Reduced time to select the optimum design by 60-80% due to running multiple design scenarios
- Automated workflows allow engineers to work on high value business decisions
- Perform advanced analysis through trusted Engineer's Desktop™ computer software.
- Automatic update of design as new real time data is available
- Integration of the well plan with well site operations for real-time plan adjustments

Modelling and operational best practices can be leveraged to minimize the risk of chemical corrosion and mechanical property degradation. NETool™ software simulations enable an image of the expected behaviour of injected CO₂ in specific reservoirs. Temperature, pressure, and flow of CO₂ in the wellbore are estimated to ensure the injected CO₂ remains within the safe boundaries. Preliminary CO₂ injection screening and probabilistic system assessments help enable decisions in preliminary stages of a CCS project.

DESCRIPTION

DWP takes well design and engineering through a standard process that can be customized for CCS well construction and design criteria.

DWP's offset well analysis enables the automated design of a new well by comparing operator defined KPIs and design parameters. It uses drag-drop capabilities to create a blueprint for the new design to automatically run engineering calculations for the new well. Offset well analysis includes:

- Casing depth selection
- Casing specifications
- Bottomhole Assembly (BHA) selection
- Fluid design
- Well barrier management
- Well operating parameters

DWP has detailed business process management workflows for the feasibility of a well prospect and the design of the well. A cloud based integrated suite of well construction technology, including EDT, takes the well construction process from trajectory design to completions design and analysis. Higher well construction performance is achieved by incorporating drilling decision optimization with integrated workflows.

WELLCAT™ SOFTWARE FOR CCS WELLS

WellCat™ software is part of the EDM suite and provides a precise solution for both wellbore analysis and integrated casing and tubing design. It calculates accurate downhole temperature and pressure profiles, which can be used for pipe-body movement and casing and tubing load analysis for production scenarios and CO₂ injection. WellCat™ software helps understand various challenges in CCS wells and different load scenarios.

DRILLING DESIGN

The Drill Design module simulates flow and heat transfer during drilling operations, providing full transient analysis.

CASING DESIGN

The Casing Design module analyzes casing loads, design integrity, and buckling behavior under complex mechanical, fluid pressure, and thermal-loading conditions with standard and automatic load-case generation. Analysis may be performed in conjunction with the Drill Design and Production Design modules, including tubingless configurations.

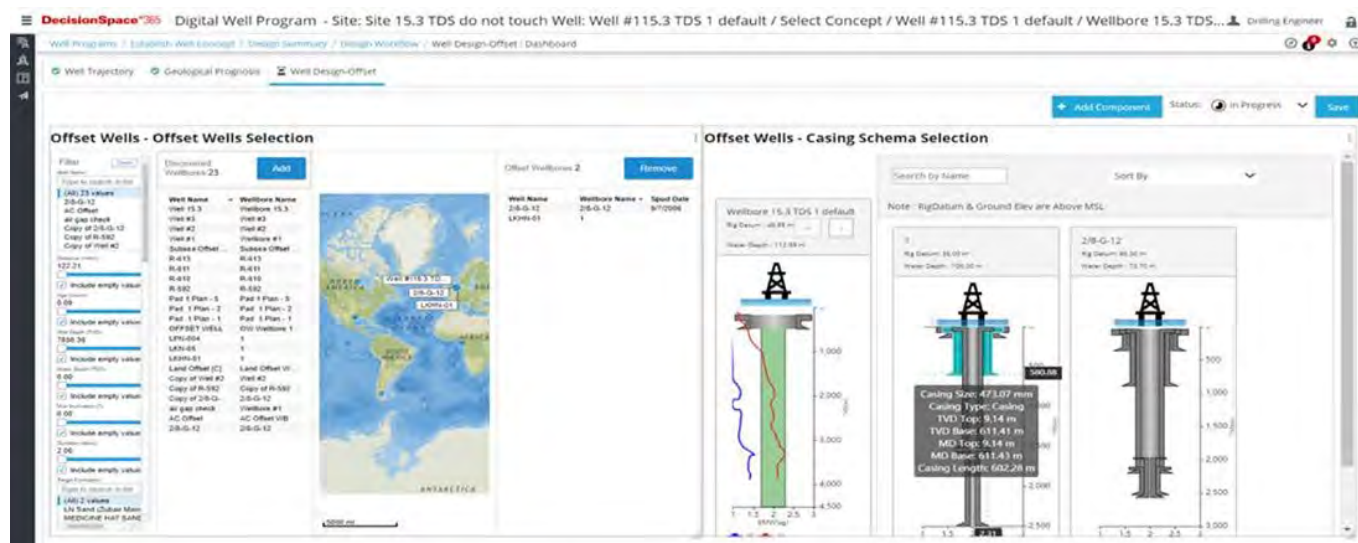

Figure 1: Digital Well Program® - Offset Well Analysis

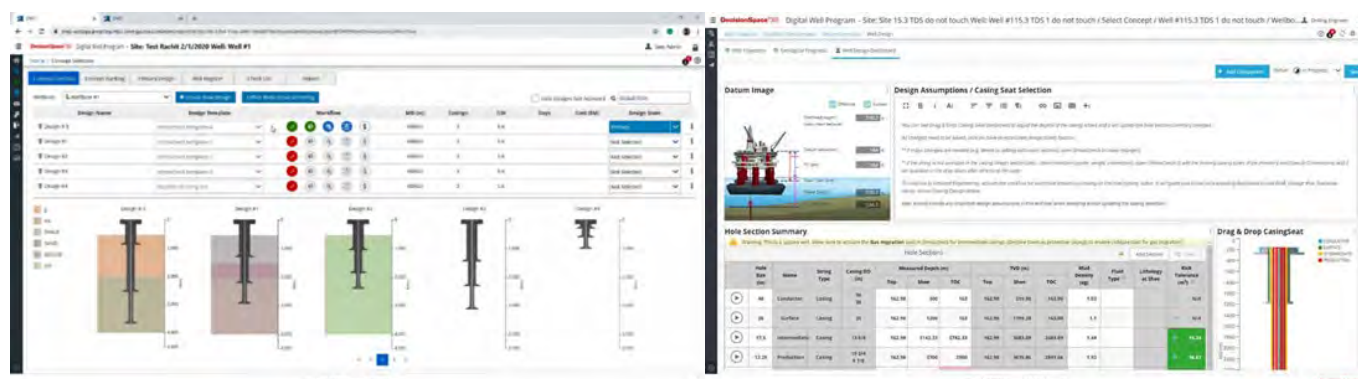

Figure 2: Digital Well Program® - Design Feasibility (Plan)

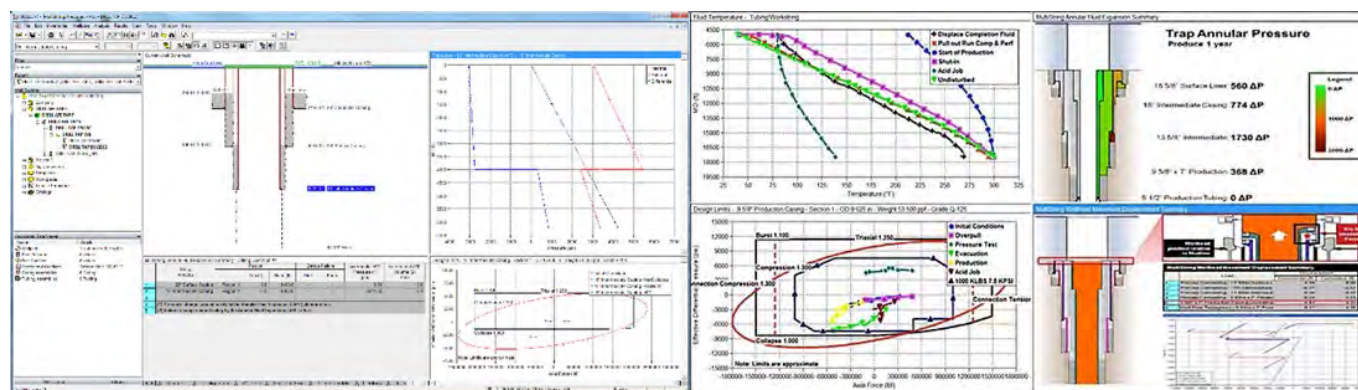

Figure 3: WellCat® Software

ANNULAR BARRIER DESIGN

Halliburton offers a tiered portfolio of chemical barriers tailored to the injection plan and isolation zone of interest. These solutions include non-Portland solutions, such as ThermoLock™ cement system or WellLock® resin system, a resin-modified cement, CorrosaLock™ cement system, and a Portland based solution, CorrosaCem™ cement system. When combined with multi-stage cementing and mechanical barriers, additional benefits may result in maximized annular fluid separation, increased cement lift to surface, and the presence of a secondary barrier.

PRODUCTION DESIGN (INJECTIVITY AND FLOW ASSESSMENTS)

This module simulates fluid and heat transfer during completion, production, injection, stimulation, testing, and well-service operations. Transient and steady-state analysis for single-phase and multiphase flow can be done with initial conditions defined by thermal results from the Drill Design module. It also offers linked analyses with the Tube Design and Casing Design modules. New collapse load assessments are incorporated (Bureau of Safety and Environmental Enforcement (BSEE), Well Containment Screening Tool (WCST)).

TUBE DESIGN

The Tube Design module analyzes tubing loads and movements, buckling behavior, and design integrity under complex mechanical, fluid-pressure, and thermal-loading conditions with standard and automatic load-case generation. Tube Design offers linked analyses with the Production Design module.

MULTI-STRING DESIGN

The Multi-string Design module predicts pressure and volume changes due to annular pressure buildup (APB) when the well system heats up as a result of drilling or production operations or the injection of hot fluids into the well. The Multi-string Design module determines the movement that occurs at the wellhead during the life of the well. Analyses are linked to Drill Design, Production Design, Tube Design, and Casing Design modules.

NETOOL™ SOFTWARE

NETool™ software is a steady-state numerical simulator that provides comprehensive modeling for the most complex wells. Designed for completion engineers operating CO₂ injection wells, this tool is a highly detailed wellbore and completion simulator for CO₂ storage design. From injection well design to execution control, it incorporates the functionality required for all phases of injectivity planning and operations. It manages outflux injection profiles along the wellbore, which gives a clear picture of the CO₂ injection zones, especially in horizontal wells. Its compositional simulation provides accurate phase behaviour in changing pressure-temperature conditions along the wellbore and built-in component properties allow for the creation of high complexity EOS models.

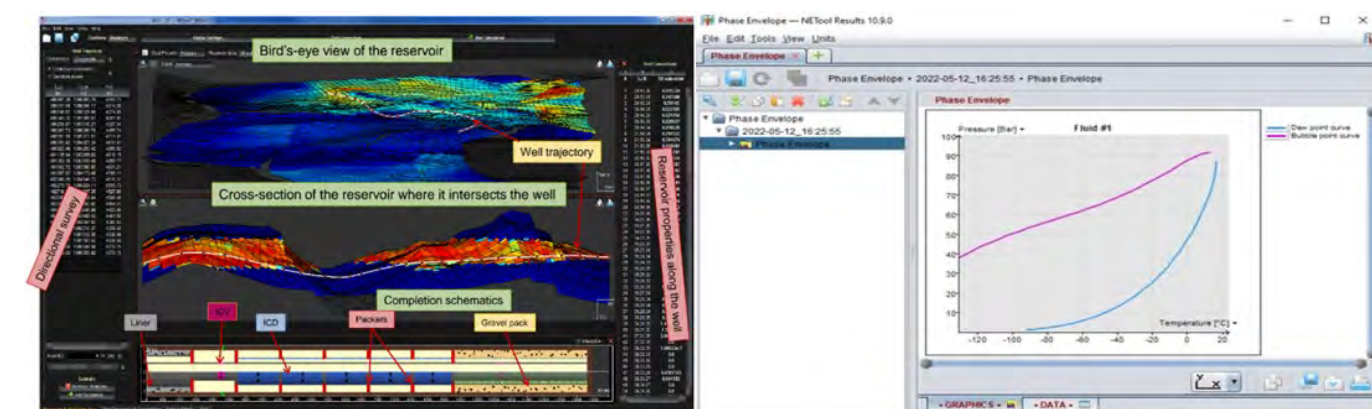

Figure 4: NETool™ Completions and CO₂ Phase Behaviour Analysis



Sleipner Plume Visualization

STORAGE CHARACTERIZATION AND PLUME SIMULATION

HALLIBURTON

SUMMARY

DecisionSpace® 365 CO₂ Storage Solution is a highly flexible cloud-based solution designed to evolve and grow with the needs of the industry as CO₂ projects are initiated and developed.

It is designed to facilitate data interpretation, modeling, and design of a CO₂ storage site from the first stages of site selection to site characterization, scenario modelling for storage resources estimation and containment and CO₂ injection assessments.

Understanding CO₂ displacement in injection intervals is important for developing effective injection strategies and estimating storage capacity. Detailed storage resource information is updated into DecisionSpace® 365 CO₂ Storage Plume software to update and confirm simulation models. Key information acquired by Halliburton's iSTAR™ intelligent drilling and logging platform and wireline Xaminer® logging services provide the detailed characterization and data to model a CO₂ storage site.

BENEFITS

DecisionSpace® 365 CO₂ Storage Plume leverages Permedia® CO₂ software to couple robust reservoir, CO₂ migration, and customized black oil simulators with an easy-to-use interface. These are integrated through a single wizard to help users set up simulation parameters and runs with easy-to-follow workflows.

CO₂ Storage Plume is flexible and able to consume existing models in a variety of data types. It allows the user to complete an end-to-end CO₂ workflow for prospecting, regional pressure modelling, plume modelling, and injection modelling.

DESCRIPTION

The DecisionSpace® 365 CO₂ Storage Solution optimizes modelling and interpretation at each critical stage of the CO₂ life cycle using a flexible approach to accessing tools. The solution facilitates specific workflows designed between applications to optimize modelling and create greater efficiency for timely results and decisions.

Within the umbrella of CO₂ Storage Solution, CO₂ Storage Plume is an integrated suite of high-resolution modelling tools and simulators for CO₂ storage exploration, monitoring, and prediction. The software addresses key aspects of CO₂ storage workflows: formation storage prospecting, capacity estimation, well injectivity, formation pressurization, plume trapping, and dissolved CO₂ dispersal.

- Prospect for new storage sites
- Assess capacity and containment for CO₂ storage
- Match storage monitoring data
- Predict the long-term fate and risks of a storage site in the post-operational phase

CO₂ Migration simulator: A CO₂-adapted invasion percolation simulator for free-phase plume modelling. CO₂ Migration is built on the state-of-the-art Permedia® CO₂ migration simulator, providing extremely high-resolution models of gravity-segregated plume distributions in heterogeneous storage settings.

CO₂ BOS simulator: A fast multi-threaded Black Oil Simulator, developed to specifically handle CO₂ storage and solubility. Specially adapted for two-phase plume and brine modelling, CO₂ BOS addresses reservoir engineering workflows for CO₂ modelling in saline formation settings. It is specifically tuned to run CO₂ injection out-of-the-box, with built-in CO₂ injection scheduling, PVT, and solubility handling.

CO₂ Flow simulator: CO₂ Flow is a high-resolution hydrodynamic solver for modelling CO₂ storage related pressure changes. With a well modelling scheme that handles CO₂ injection rates and injection interval pressures, CO₂ Flow offers a high-resolution regional simulation for testing the boundary conditions of high-resolution heterogeneous meshes for regional pressure models.

CO₂ Dashboard: CO₂-specific equation-of-state and PVT wizard for initializing simulations. The CO₂ Dashboard is used to initialize model conditions: gas and brine phase density, compressibility, viscosity, solubility, and interfacial tension. The wizard has been validated against several published works containing both theoretical and experimental data. Initial model conditions for these key properties can be automatically transferred from the Dashboard to the CO₂ simulators.

MODEL CALIBRATION

The iSTAR™ intelligent drilling and logging platform and wireline Xaminer® (XSI™, XMR™, STX™, RDT™) services provide the necessary detailed rock and fluid properties, structure and fault analysis, rock mechanics, pressures, and samples to characterize and simulate a CO₂ storage site fully. Integrated rock analysis provides detailed heterogeneity and texture mapping to logs and fast CO₂ relative permeabilities and sensitivity to advance simulation while waiting for physical core.

The ability to “see” small quantities of CO₂ outside the injection reservoir is critical for confirming well integrity and that no CO₂ has entered diffusion or aquifer zones above the injection reservoirs.

IntelliSat™ pulsed neutron logging service is Halliburton's latest generation Multi-Detector pulsed neutron tool that provides accurate and robust Sigma, Hydrogen Index and Carbon/Oxygen ratios from the wellbore environment. It also measures individual energy yields for aluminium, carbon, silicon, oxygen, and 21 other discrete elements. This is the only tool that gives definitive change in saturation which will impact injection conformance monitoring and update to simulations.

A strong differentiator of Halliburton's IntelliSat™ pulsed neutron logging service is the use of a third detector. This Long detector is designed to read primarily neutron interactions in a partially gas filled environment given the low density of gas. This gas saturation measurement, SatG™ (Chen, Jacobson, Guo, SPWLA-2015-AAA), derived from long inelastic count rates, is even more sensitive in the presence of CO₂. A methodology derived by Halliburton for CO₂ injection in depleted gas zones yields a SatQ, (Quintero, Guo, Gales SPWLA-2022-0091) which represents the CO₂ saturation in the near borehole region, exclusively.

The tool's superior and unique resolution of 2% (Sigma, C/O) allows for detection of minute changes in CO₂ saturation whether the injection is in depleted gas or water zones.

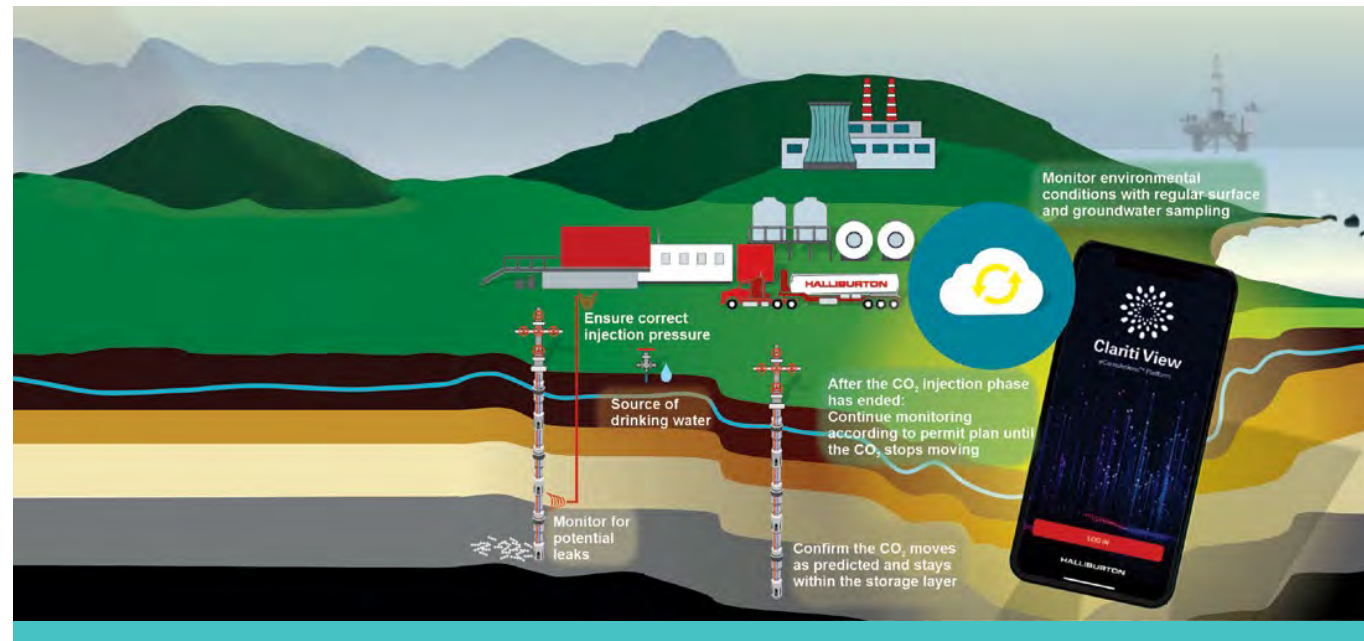

CAPROCK AND WELL INTEGRITY MONITORING: SUBSURFACE (IN-WELL) MMV SOLUTIONS

HALLIBURTON

SUMMARY

Well integrity plays a vital role in the profitability of a project or asset. Regular well inspection provides assurance of the system's integrity and containment, which reduces uncertainties and risks associated with CO₂ storage like erosion from drilling or workovers, corrosion, and geomechanics constraints. Unexpected well damage or containment issues can jeopardize assets and CO₂ containment.

Caprock and well integrity are critical monitoring objectives for MMV (Measurement, Monitoring and Verification) plans.

Well sensor measurements acquired with DataSphere® monitoring systems, as well as Distributed Temperature Sensing (DTS) fiber optics and Distributed Acoustic Sensing (DAS) provide a holistic monitoring approach where both tubular and caprock leaks can be determined in real time. A downhole system can be combined with seabed monitoring solutions such as tiltmeters and seismic to design a system that is scalable alongside the CO₂ injection radius growth.

BENEFITS

Benefits from the holistic cap rock and well integrity monitoring system can be outlined as follows:

- Comprehensive azimuthal cement evaluation to insure injection zone isolation and containment with CAST™ (Circumferential Acoustic Scanning Tool)
- Radial bond log and baseline tubular inspection for time lapse comparison of erosion and/or corrosion with EPX™ (Electromagnetic Pipe Xaminer®, CAST™ or MFC (multi-finger caliper)
- Active pressure and temperature monitoring in the wellbore, multi-point P/T across the reservoir, caprock and in A-annulus and/or B-annulus with DataSphere® Opsi®, Array and LinX®
- Active well integrity monitoring with LinX®, DTS and DAS

- Ability to monitor far field cap rock condition with DAS Microseismic
- Combining surface pressure measurements with tiltmeter microdeformation monitoring, available both on land and subsea, results in robust caprock monitoring
- Approach for legacy, plugged, and abandoned wells for well integrity screening with Microdeformation monitoring
- Integrate with Clariti® View to provide a seamless solution to access Array sensor data remotely from any device, without having to install or maintain the infrastructure necessary. The monitoring platform stores data in a secure cloud and provides access via the Clariti View visualization dashboard, where the operator can view live data, download historic data and set alert triggers to stay ahead of any remediation needs. This also helps ensure the operator meets regulatory agency reporting requirements with up-to-date information."

DESCRIPTION

The safe and successful design and operation of CO₂ injection and observation wells requires careful consideration of several technical challenges. To maintain well integrity, it is essential to understand the reservoir and factors such as caprock integrity, potential leak paths, and legacy, plugged, and abandoned (P&A) wells.

Analyzing cement condition and bonding confirms zonal isolation and/or identifies the possibility of fluid migration through channelling or poor cement areas. These technologies are acoustic, therefore are affected by the fluids, solids, and scaling material in the well. The Circumferential Acoustic Scanning Tool (CAST™) is an ultrasonic tool that provides high-resolution images in cased holes. The tool's interchangeable head rotates a full 360° and contains a high-frequency acoustic transducer to provide a comprehensive evaluation of the pipe and cement. The CAST™ tool determines the casing thickness for pipe inspection and determines the type of material in the annular space between the casing and borehole wall. Advanced software analysis is available which can provide additional information on cement bond and well integrity.

Halliburton's Radial Cement Bond Log (RCBL™) tool captures downhole data to ensure a reliable cement-bond evaluation for a full range of thru-tubing logging and casing completions, from small diameter tubing to large casings.

The Halliburton Electromagnetic Pipe Xaminer® V (EPX™ V) pipe inspection service quantifies metal loss in one to five concentric strings of pipe in a wellbore using accurate High-Definition Frequency (HDF) technology. This capability and 1 11/16" OD enable examining the whole well in one trip and assessing pipe condition quickly through tubing. This unmatched capability enables customers to reduce diagnostic time, obtain comprehensive information for monitoring programs, and determine the right solution for a nonconformity in their completion.

With the DataSphere® monitoring systems platform, Halliburton delivers a broad portfolio of highly accurate, Quartz based sensor solutions that give advanced pressure and temperature insights. This extensive portfolio is AWES certified and includes LinX® behind casing wireless monitoring, Opsi® tubing deployed gauges, and industry leading DataSphere Array multi-point pressure temperature allowing for distributed pressure sensors across all injection intervals. The various sensor solutions within the DataSphere platform feature field proven, robust solutions including single billet mandrels with no connection, full redundancy, a range of metallurgy

and thread connections, and unparalleled deployment options allowing for reliable, efficient installation. These sensor solutions combine to provide zonal connectivity insights, CO₂ migration patterns, and reliable life of well confirmation of containment.

Advanced solutions that encompass an array of monitoring tools, including Distributed Acoustic Sensing (DAS), Distributed Temperature Sensing (DTS), microdeformation monitoring (tiltmeters, GNSS, InSAR), and Microseismic monitoring, providing accurate insights.

DAS monitors acoustic signals within the wellbore to identify potential leaks and establish their exact locations, while DTS tracks temperature changes that signify fluid movement and possible leak points. Collectively, they provide a thorough understanding of the wellbore environment to facilitate early detection and remediation of wellbore integrity issues.

The risks of out of zone injections (OOZI), where CO₂ migrates beyond the target storage area, may pose potential threats to the environment and storage integrity. DAS and DTS help monitor and detect OOZI. DAS senses variations in fluid movement and pressure that may indicate CO₂ migrating out of the target zone, while DTS identifies temperature anomalies related to out of zone CO₂ migration. By utilizing these tools, rapid detection is enabled, to help ensure containment and conformity.

Microseismic monitoring plays a critical role in caprock integrity monitoring by capturing and analyzing microseismic events to detect fracture propagation and fluid migration within the caprock. Combining surface microseismic monitoring with DAS microseismic improves event detectability and location accuracy, ensuring a comprehensive understanding of subsurface dynamics and enhancing caprock integrity protection.

Old, inaccessible legacy wells can be monitored with surface techniques and far-field microdeformation techniques. These measurements provide a systematic approach to caprock and well integrity monitoring.

Downhole and surface sensors combine to provide a robust and integrated solution, which will deliver valuable reservoir insights as well as superior performance and enhanced well-monitoring capabilities. With our MMV solutions, our customers can have confidence in the reliability and accuracy of their implemented monitoring systems to enable optimal CCS operations.

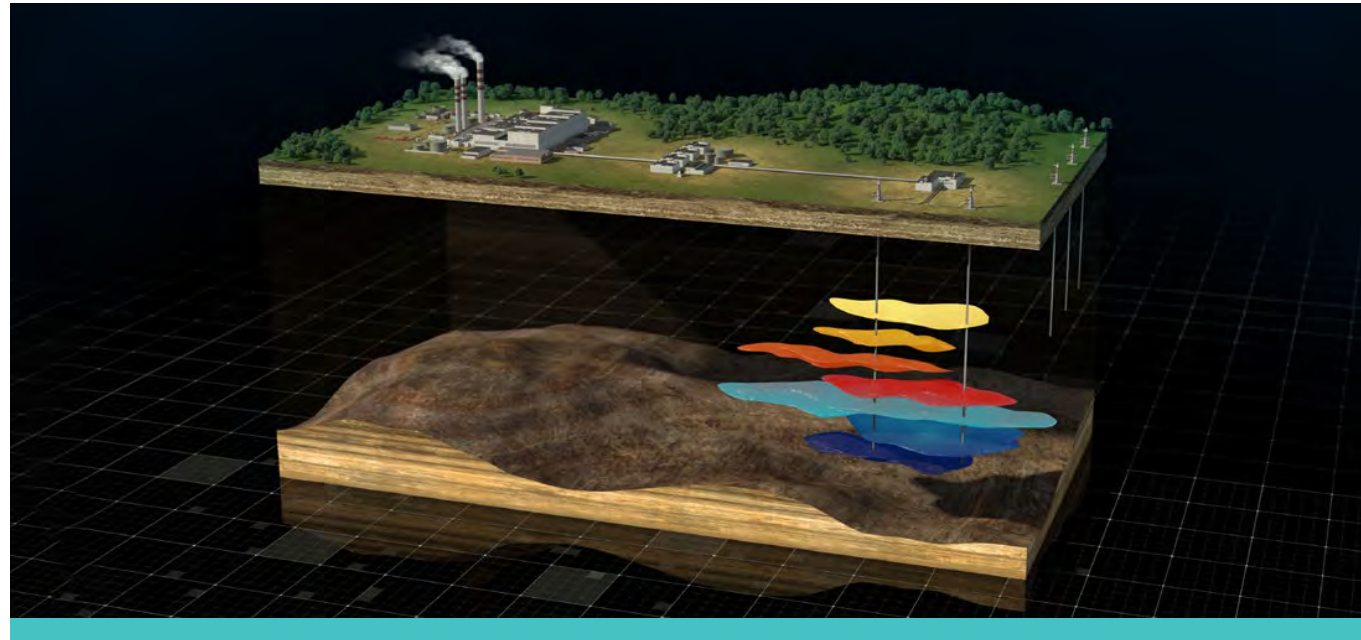

CAPROCK INTEGRITY & CO₂ PLUME MONITORING: SURFACE/SEABED MMV SOLUTIONS

HALLIBURTON

SUMMARY

Conformance and containment are crucial for successful CCS operations and require CO₂ plume monitoring and caprock integrity throughout the project's lifetime. Halliburton's FiberVSP™, a Distributed Acoustic Sensing (DAS) based solution, captures high-resolution subsurface images and provides a cost-effective, versatile approach for CO₂ plume tracking. When combined with

Microdeformation Monitoring technologies—tiltmeters, GNSS, and InSAR—offer reliable caprock breach detection, long-term fluid balance tracking, and calibration values for reservoir and fracture growth models to ensure MMV (Measurement, Monitoring and Verification) plan compliance.

BENEFITS

- Comprehensive monitoring: Combining FiberVSP™ with Microdeformation Monitoring techniques offers a robust approach for tracking CO₂ plumes and ensuring caprock integrity throughout CCS projects
- Model calibration: Microdeformation Monitoring provides valuable data for calibrating reservoir and fracture growth models to enhance the accuracy of predictions
- Early leak detection: FiberVSP™ and Microdeformation Monitoring technologies contribute to swift identification and precise localization of leaks, allowing for timely remediation
- Improved safety and containment: By effectively tracking fluid movement and detecting potential breaches, FiberVSP™ and Microdeformation Monitoring help ensure the CO₂ plume remains confined within the reservoir

DESCRIPTION

Conformance and containment, pillars of any MMV plan, must be ensured to achieve a successful CCS operation. Conformance can be achieved by ensuring the injected CO₂ behavior in the storage complex matches the models, while containment is fulfilled by putting in safeguards to have the CO₂ plume confined in the reservoir and preventing any uncontrolled release of fluids through the primary or secondary seals. To achieve conformance and containment, the CO₂ plume needs to be monitored and tracked throughout the lifetime of the project, while also monitoring caprock integrity.

Given its higher resolution and image quality, VSP (Vertical Seismic Profiling) is an effective tool for monitoring and tracking the CO₂ plume. DAS has emerged as a cost-effective alternative to conventional VSP, offering comparable imaging quality. Halliburton offers FiberVSP™ service, a DAS based VSP solution, that when combined with other monitoring tools, provides a comprehensive approach to monitor and track the CO₂ plume.

Key Features of Halliburton's FiberVSP™ service:

- DAS enables the capture of high-resolution subsurface images, which is essential for accurate CO₂ plume tracking and caprock integrity monitoring. Featuring a denser sensor array than traditional geophones, DAS collects extensive, top-quality data with exceptional spatial and temporal resolution
- By requiring a much smaller footprint at the wellsite, DAS offers a cost-effective solution for VSP surveys to enable more repeatability
- To address diverse CCS applications and environments, the fiber optic cable can be permanently installed for long-term monitoring or deployed for temporary surveys, providing flexibility in MMV plans

In conjunction with FiberVSP™ service, Halliburton offers Microdeformation Monitoring as an additional tool for CO₂ plume and caprock integrity monitoring. This technology has been in commercial use for over 30 years and is robust across a wide range of formation properties. It provides valuable model calibration data and is more cost-effective than repeat seismic surveys.

Continuous CO₂ injection could potentially cause fluid migration in formations either by moving through the rock matrix or by opening a fracture system. Both processes result in rock motion transmitted elastically in all directions, which can be detected at the ground surface or seabed with precise measurements. These insights are essential to ensure the containment and conformity of CCS initiatives.

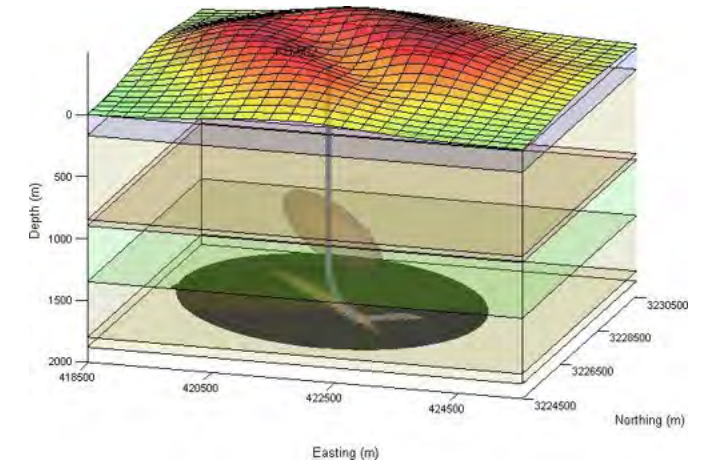

Microdeformation measurement through Tiltmeters

Three main technologies in Microdeformation Monitoring—tiltmeters, GNSS (Global Navigation Satellite Systems), and InSAR (Interferometric Synthetic Aperture Radar)—can be combined to optimize monitoring programs. They offer reliable caprock breach detection, long-term fluid balance tracking, and calibration values for reservoir and fracture growth models. Each one contributes to MMV plan compliance in CCS projects.

Tiltmeters are extremely sensitive instruments used to map hydraulic fracture orientation for treatments as deep as 5000 meters and provide rough locations of fluid volumetric centers for shallower processes. These sensors can be used on surface, downhole, or maritized to be used for seabed deformation monitoring.

GNSS, which includes the United States' GPS constellation, has a lower measurement resolution than tiltmeters but can be integrated into a tiltmeter array to limit long-term measurement uncertainties. The advantages of GNSS include three-axis measurements and absolute output relative to a global frame of reference. Incorporating a few GNSS measurements into a tiltmeter provides both short-term sensitivity and confidence in deformation measurements over project timescales.

InSAR uses radar measurements, primarily from purpose-built satellites or airborne systems, to measure motion at near GNSS levels of sensitivity over a large area with fine pixel resolution. Dense coverage ensures that areas requiring higher precision monitoring are not overlooked.

The combination of tiltmeters, GNSS, and InSAR technologies offers a comprehensive and adaptable solution for monitoring caprock and well integrity in CCS projects. By leveraging these techniques, operators can help ensure MMV plan compliance and promote the long-term viability and safety of CCS initiatives.

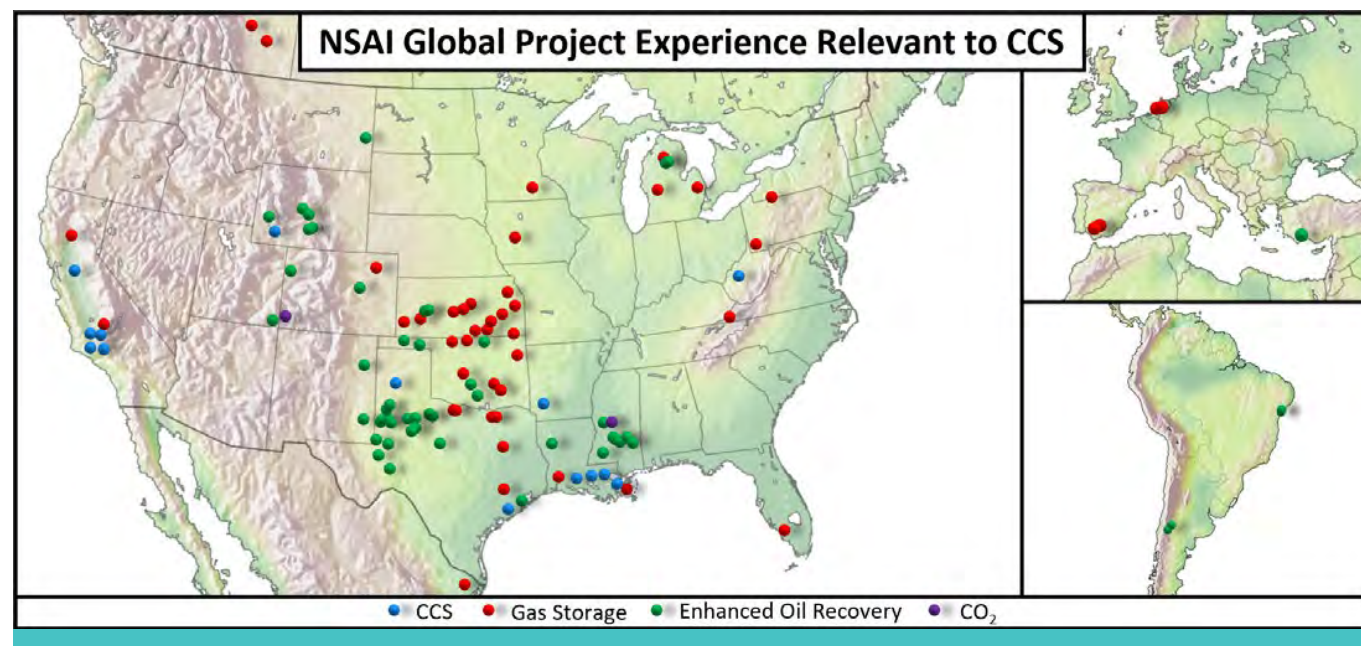

GEOLOGIC MODELING, RESERVOIR SIMULATION AND CARBON STORAGE CERTIFICATIONS NETHERLAND, SEWELL & ASSOCIATES, INC.

SUMMARY

Whether injecting into depleted hydrocarbon-bearing formations or into regionally extensive aquifers, NSAI has the expertise to certify the subsurface aspects of your carbon capture project. As a leader providing petroleum engineering and geology evaluation services to industry for over 60 years, NSAI staff can bring to bear an unparalleled skill set.

NSAI has geological staff that are experts at seismic interpretation and integration of well data to map formations, as well as reservoir engineering teams that are experts in dynamic modeling of fluid flow and CO₂ storage processes. NSAI also employs specialized economic modeling software and capabilities to accurately quantify project value.

BENEFITS

- **Experience** – NSAI has over 60 years of experience in integrated subsurface studies, providing technical and advisory services for clients in over 100 countries, both onshore and offshore. NSAI has evaluated dozens of natural gas storage projects and more than 10 permanent CO₂ sequestration projects.
- **Reputation** – NSAI is known for the high quality of our work, the excellent service we provide to our clients, our strong respect for confidentiality, and our independence from the clients and properties for which we prepare evaluations.
- **Expertise** – NSAI has the technical skills needed for all subsurface aspects of CCS projects, including well planning, regional geology characterization, local geologic structural mapping, storage reservoir characterization, log and core data analysis, fluid PVT analysis, static and dynamic simulation modeling, and injection performance surveillance.
- **Trusted Analysis and Advice** – At NSAI, our goal is to be more than just a consultant; we strive to be a trusted advisor to our clients through full project life cycles and beyond.

DESCRIPTION

Since relatively few carbon sequestration projects are online to use as analogs, the subsurface assessments of these projects rely heavily on reservoir simulation. Geoscience and engineering teams collaborate to build geocellular models and upscale for dynamic simulation of storage reservoirs.

NSAI has built hundreds of models and has efficient, fit-for-purpose workflows that can tailor a model to the specific needs of any client. These models can provide insight into key reservoir uncertainties pre-injection or deep insight into storage mechanisms once history-matched to actual performance data.

NSAI is also an industry leader in gas storage evaluations in North America. We have worked over 40 storage projects for our clients, assisting in area of review (AoR) updates, identifying and resolving wellbore issues, field studies, litigation, and more.

This experience has given NSAI a thorough understanding of all storage containment issues, with expertise in studies to support initial permitting and ongoing regulatory obligations. Additionally, NSAI has prepared thousands of reports using the definitions of the Petroleum Resources Management System (PRMS) of the Society of Petroleum Engineers (SPE). The SPE's classification system for CO₂ storage, the Storage Resources Management System (SRMS), closely parallels the PRMS, and commerciality of projects is a key aspect.

Beyond storage fees, tax credits, and government subsidies, CCS projects evaluated under SRMS can be coupled with a revenue- and CO₂-generating project for commercial determinations. NSAI's time-tested processes for evaluating project technical and economic aspects are highly respected in the investor community.

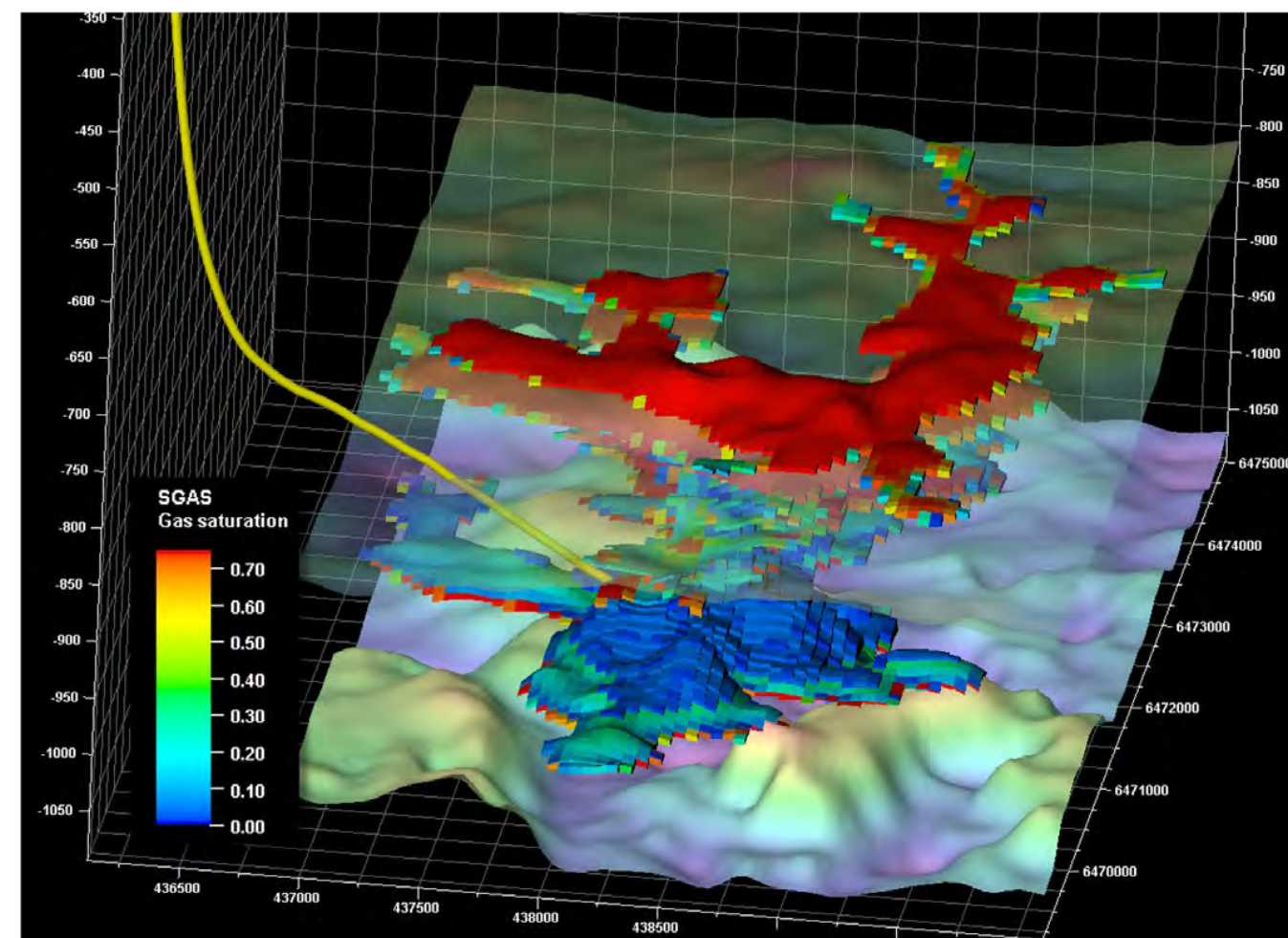

NSAI integrated geologic modeling and reservoir simulation of Sleipner Field CCS Project CO₂ plume migration.



CCUS OFFERINGS BY QUORUM QUORUM SOFTWARE

SUMMARY

Quorum Software is a leading provider of energy software worldwide, serving more than 1,800 customers across the entire energy value chain in over 55 countries. Quorum's solutions power growth and profitability for energy businesses by connecting people, workflows, and systems with decision-ready data. Twenty years ago, we delivered the industry's first software for gas plant accountants, and today our solutions streamline business operations with industry-forward data standards and integrations. The global energy industry trusts Quorum's experts and applications to successfully navigate the energy transition while delivering value today and into the future.

BENEFITS

- In-depth analysis to support decision-making
- Understand the value of your assets and unlock their hidden value
- Greater consistency across asset teams
- Spend less time compiling data and ensuring data quality
- Transparency and governance to your data and processes
- Future-proof your business as the energy transition accelerates

For more information, visit www.quorumsoftware.com.

Quorum is developing solutions for the energy transition in many different areas including a) Carbon Capture, Utilization, and Sequestration b) Corporate Planning & Strategy c) Emissions Management d) Hydrogen & RNG, and e) Utility Scale Renewables. Below we outline a portion of our energy transition portfolio specific to CCUS. For a complete picture, please see our website:

<https://www.quorumsoftware.com/solutions/energy-transition/>

DESCRIPTION

CARBON STORAGE RESOURCES MANAGEMENT

In a low-carbon environment, underground CO₂ storage has the potential to be a cash-flow generating asset. This includes both mature, operational CCS projects as well as immature, future CCS projects. Like all corporate assets, CO₂ storage owners should track and estimate the value of all CO₂ storage assets. Quorum's Carbon Storage Resources Management solution enables CCS operators to analyze the capacity of their CO₂ storage assets and understand how that capacity is changing over time.

Benefits

- Track and analyze the full portfolio of CO₂ storage assets – Quorum's Carbon Storage Resources Management application serves as a single source of truth for a full portfolio of CO₂ storage assets.
- Supports SPE's CO₂ Storage Resources Management System (SRMS) - align with the industry standard framework for managing and reporting CO₂ storage resources.
- Spend less time gathering data – engineers will have more time to analyze storage resources data and support decision-making.
- Reduce risk of data entry errors – company-specific data quality checks to identify errors early in the data gathering workflow.
- Scalable for companies of all sizes - from small independents to international supermajors, companies around the world can take advantage of our solution.
- Future proof your CO₂ storage business – capture and report CO₂ storage resource estimates in a structured manner in preparation for future regulatory requirements.

Description

Quorum's Carbon Storage Resources Management is a cloud-based solution that captures storage estimates across a resource owner's full portfolio of assets from mature, operational projects to less mature contingent or prospective storage resources. It is a best practice for a resource owner to gather estimates for all storage assets – to understand their value in the context of all corporate assets and prioritize investment accordingly.

The capacity of CO₂ storage assets changes year-over-year for a variety of reasons such as reservoir performance or economic conditions. Quorum's Carbon Storage Resources Management solution reconciles year-over-year changes allowing a CO₂ storage owner to understand which factors are driving fluctuations in estimated reservoir capacity. The diagram below illustrates the change in CO₂ storage estimates over the course of a year. The starting estimate is represented by the bar on the left side. The ending estimate is represented by the bar on the right side. The items in between reconcile the difference in starting and ending estimates due to technical or economic factors:

Quorum's Carbon Storage Resources Management application is an extension of one of Quorum's world-class software applications. Our application, Quorum Reserves, is used by oil and gas producers to track, estimate, and analyze oil and gas volumes in underground reservoirs. The same technology in Quorum Reserves has been used for Quorum's Carbon Storage Resources Management software application.

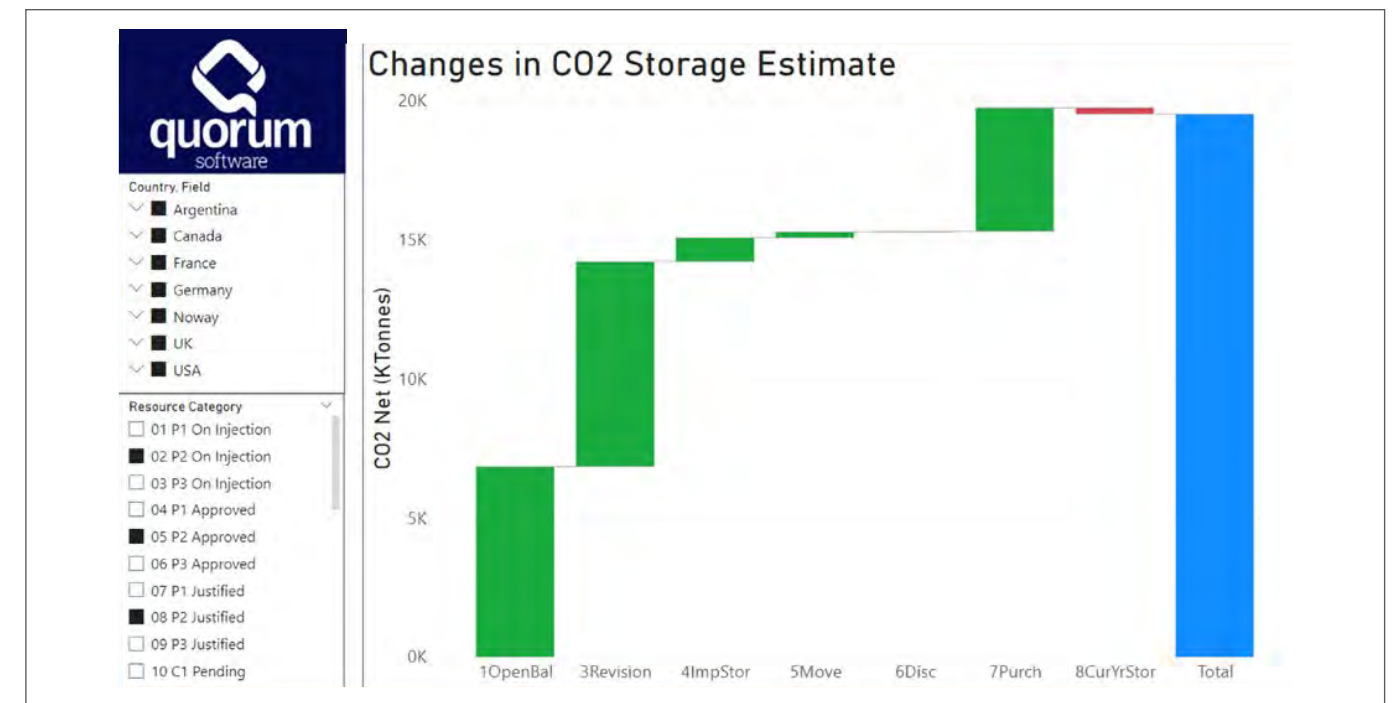

Storage Resources Management Standard (SRMS)

The Society of Petroleum Engineers (SPE) has developed a common framework for resource owners to account for CO₂ storage resources called the Storage Resources Management Standard (SRMS). Quorum's Carbon Storage Resources Management application aligns with the SRMS framework.

The above diagram illustrates the structure of the SRMS framework. It has two axes. The vertical axis indicates the maturity of a CCS project which is measured by the chance of commerciality. The most mature projects are accounted for as "capacity", followed by 'contingent storage resources' and finally the least mature "prospective storage resources." The horizontal axis indicates the range of uncertainty of CO₂ storage capacity in a resource. As a project matures toward commerciality there is typically a narrower range of uncertainty. Resource owners usually capture three deterministic estimates of a CO₂ storage resource: a low estimate, a best estimate, and a high estimate.

A standardized framework such as the SRMS empowers CCS operators to have a common basis of understanding to describe CO₂ storage resources in different jurisdictions across different companies. Quorum's Carbon Storage Resource Management application aligns with the SRMS framework. Like other resource-based industries, Quorum foresees a regulatory environment that requires CCS operators to publicly disclose their CO₂ storage resources using a framework such as the SRMS. Quorum recommends that operators future-proof their CO₂ storage business by adopting a standardized, auditable application to capture storage resource estimates.

Please see our website: <https://www.quorumsoftware.com/solutions/energy-transition/carbon-capture-utilization-and-sequestration/carbon-storage-resources-management/>

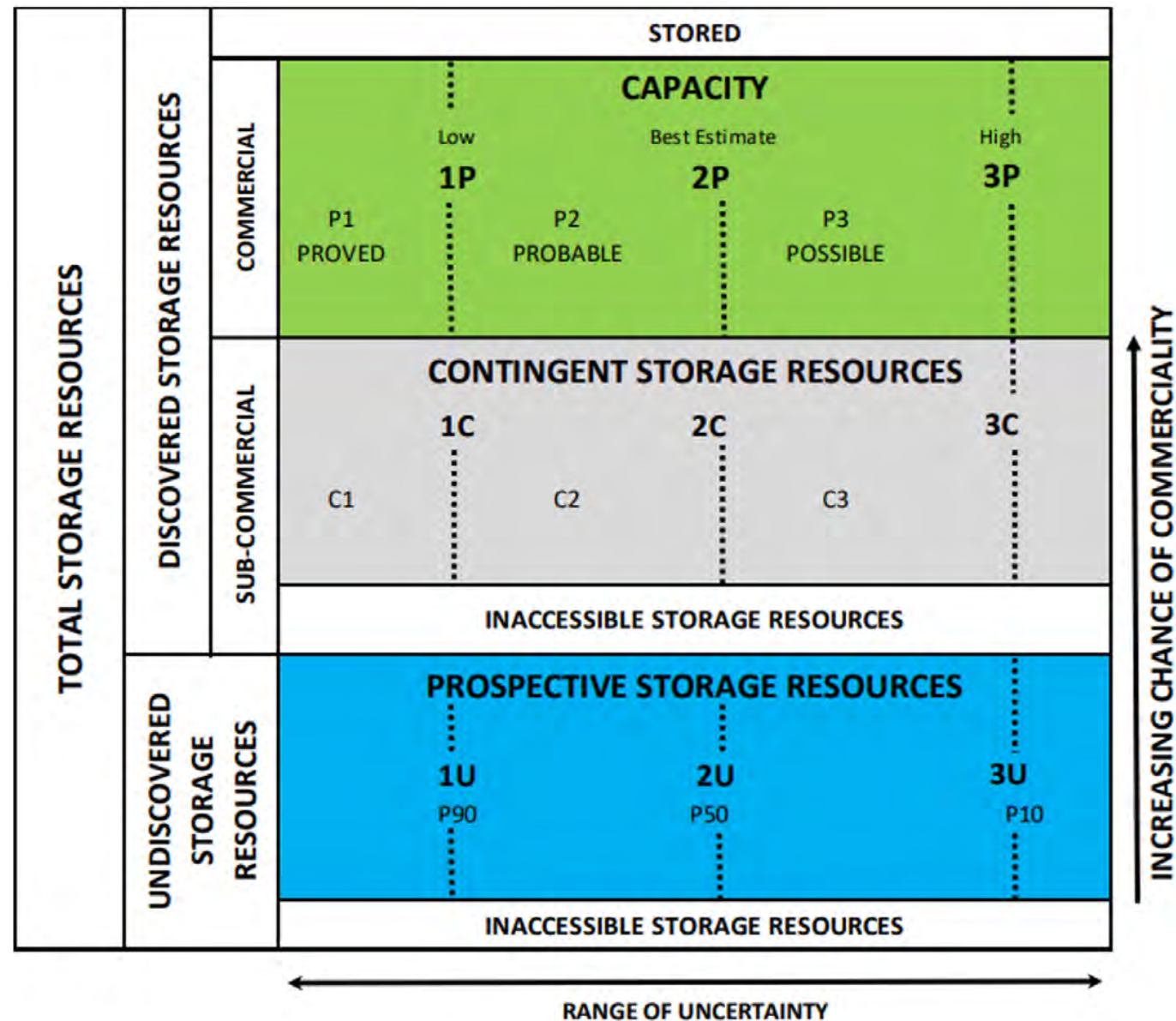

PETROVR

Planning and developing Carbon Capture, Utilization and Storage projects necessitates the integration of the input of many technical and commercial functions. The quality of this integration, together with the ability to assess effectively and transparently all alternative development options, is essential to maximising the value of these projects. Furthermore, these projects are fraught with uncertainties, from the storage capacity, the costs and performance of all the wells and facilities involved as well as scheduling of the execution and operational activities. Throughout the maturation of these projects, storage owners are faced with decisions such as how many CO₂ injection wells are needed, what should the capacity of transmission pipelines and/or processing facilities be, and how to manage risks associated with the development? Each of these decisions will impact the success of the project both in terms of financial success and amount of CO₂ that can be captured and safely stored. Quorum's PetroVR application empowers engineers and planners to assess and compare all the development alternatives available, factoring in the impact of the risks and uncertainties into the decision-making process throughout the maturation process of these large and complex CCUS projects.

Benefits

- Enhance CCUS project evaluation through integrating simulation covering all technical and commercial aspects in one single application.
- Streamline CCUS project evaluation by integrating simulation of all technical and commercial aspects into a single, comprehensive application.
- Improve the quality of the CCUS project development decisions throughout the project maturation process with the ability to assess and compare transparently

and consistently the various development alternatives available, understand the trade-offs between these, and select the one that fits best your corporate strategic objectives. Understand the impact of the project risks and uncertainties and factor this into the decision-making process.

- Simulate the development of your CCUS project under uncertainties through Monte Carlo analysis.
- Manage production goals and net-zero commitments – actualize the challenges of net-zero development with easily configurable tooling to enable development planning and production optimization.

Description

Quorum's PetroVR application is a comprehensive full-cycle, integrated simulation software for exploration and development projects including specific functionalities to cover the CCUS use-case.

PetroVR is built on more than 20 years of oil & gas field development experience. It permits engineers and planners to configure the model of their asset as necessary to reflect specific areas of complexity. It has an integrated simulation capability where users can specify any object and associated activities necessary to model their project throughout its life cycle. This includes reservoirs, wells, and facilities but also specific CO₂ storage: CO₂ injection wells and CO₂ injection facilities. An illustration is provided in the figure below.

The application simulates the project execution and operation in a time step fashion covering the entire life of the project, consistently applying inputs, constraints and rules as specified by the user and thereby computing the expected production and injection volumes as well as the associated costs incurred through time, allowing the assessment of the economic viability of the project.

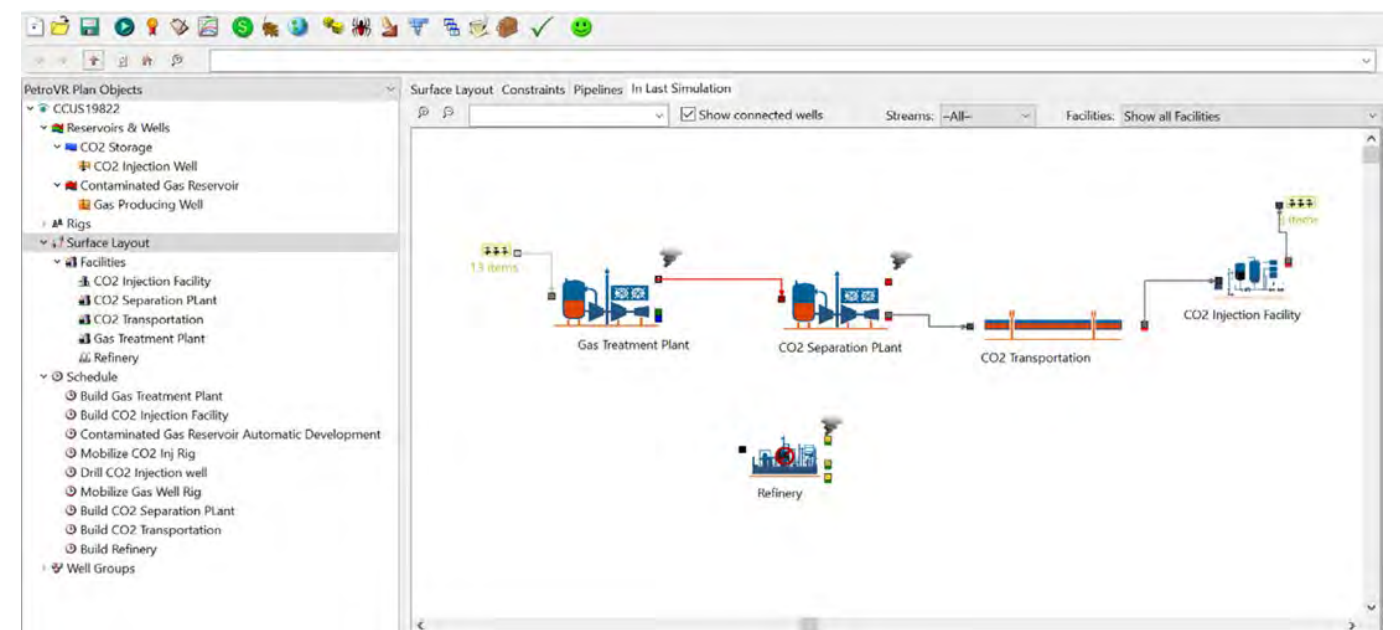

In addition to simulation capabilities, PetroVR has an advanced scenario manager enabling the easy and transparent generation of alternative development scenario models. This functionality facilitates the comparison of the development alternatives identified by the user making the “what if” analysis easy, transparent, and greatly enhancing the ability to generate insights into the trade-offs between decisions.

Many project engineers and planners rely on aggregating inputs from various spreadsheets to model their field development plan and possible alternatives. While spreadsheets are flexible, they are prone to errors. The approach is often cumbersome, time-consuming and does not offer any standardization across asset teams. PetroVR permits companies to replace spreadsheet modelling with a powerful business simulation approach that integrates all the elements of their project.

The PetroVR application facilitates probabilistic analysis through its easy-to-use Monte Carlo functionality. Users can specify the range of uncertainty for every input variable

that they need to consider in the evaluation of the project and generate the full range of expected outcome for any selected value measure reflecting all the uncertainties specified (see example below). CCUS are large and complex projects with many technical uncertainties as well as commercial. Factoring these uncertainties in the decision-making process is essential.

Quorum’s PetroVR application has a long-standing track record of adding value and reducing risks associated with field development. CCUS operators can take advantage of this application’s powerful simulation, scenario analysis and probabilistic evaluation capabilities to guide and support their project development decision-making.

Please see our website: <https://www.quorumsoftware.com/solutions/planning-economics-reserves/asset-development-planning/petrovr/>

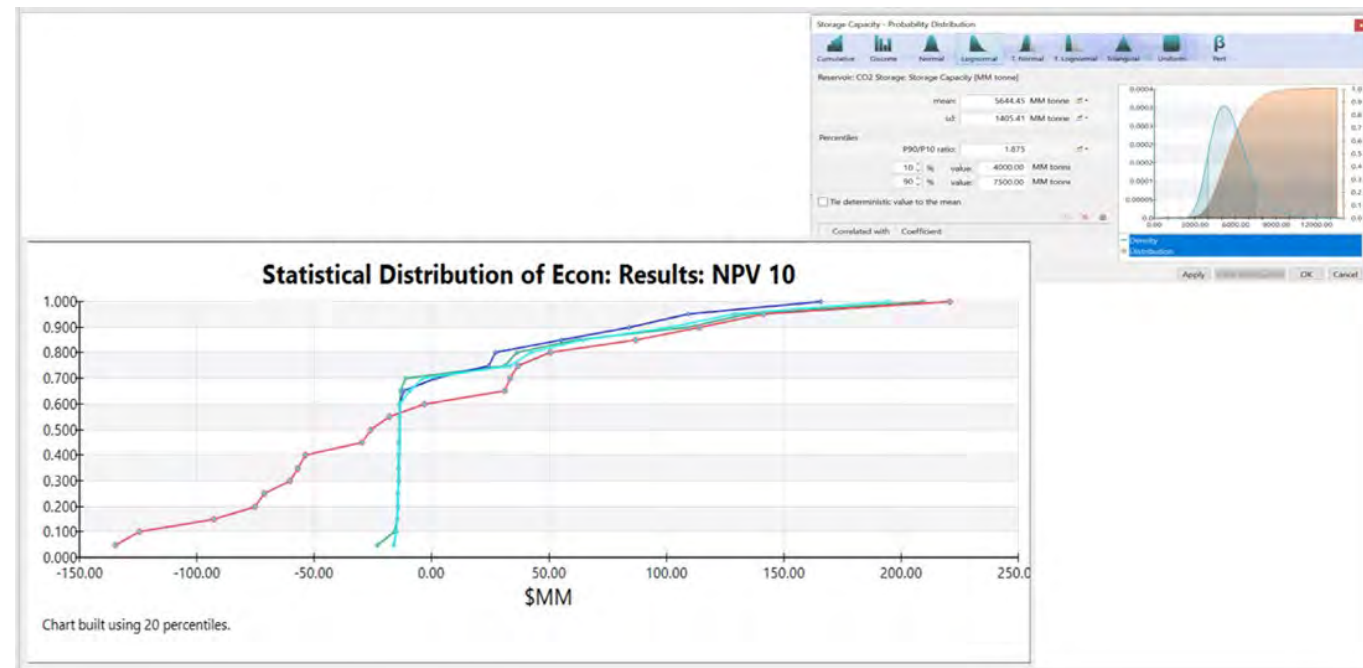

FLOWCAL

The Carbon Capture and Storage (CCS) process involves collecting (capture) CO₂ from industrial processes or from the atmosphere, transporting the CO₂ via pipelines and injecting it into underground geologic formations. During this highly technical process, CO₂ is handled in both gas and liquids (supercritical) phases making accurate measurement data management both a challenge and a requirement for successful and ongoing profitability of CCS projects.

The responsibility of custody transfer measurement points means CO₂ must be measured and correctly accounted for at the capture point, pipeline inlets, pipeline outlets, pipeline linepack/inventory, storage injection points, and finally, the storage inventory must also be tracked and balanced. A CCS operator must have a strong toolset to consolidate, review, correct and distribute an immense amount of measurement data across the organization. In addition, the CCS operator must perform this with the knowledge that the measured CO₂ and inventory are accurate to minimize legal and financial exposure and maximize revenue.

FLOWCAL by Quorum is the tool that enables CCS operators manage CO₂ measurement data.

Benefits

- Support for CO₂ measurement in both gas and liquids (dense) phase
- Support for a wide range of metering technologies such as coriolis, ultrasonic, orifice, linepack/linefill, caverns, etc.

- Compliance with measurement industry standards and regulations
- Physical balancing by volume and mass
- Meet internal and external audit requirements.
- Financial risk reduction/elimination

Description

FLOWCAL by Quorum Software is one of the most robust measurement data management systems available, streamlining the measurement process and optimizing data integrity. Designed to operate as a data warehouse capable of serving the needs of an entire organization, FLOWCAL provides a corporate solution for the most demanding system requirements. It can be applied to CO₂ measurement, hydrocarbon measurement (gas and liquids), helium and hydrogen measurement.

FLOWCAL is used by the largest energy producers and midstream operators to ensure every drop of hydrocarbon is reviewed and accounted for. New CCS operators are starting to rely on FLOWCAL to ensure their stringent measurement needs are met in support of their financial goals. FLOWCAL has an extensive toolset to avoid costly errors by using validation routines that flag erroneous data and identify issues in the field, reduce measurement uncertainty, identify ‘Lost And Unaccounted For’, physical system balance, and minimize risk by ensuring compliance, data transparency and a complete secure audit trail.

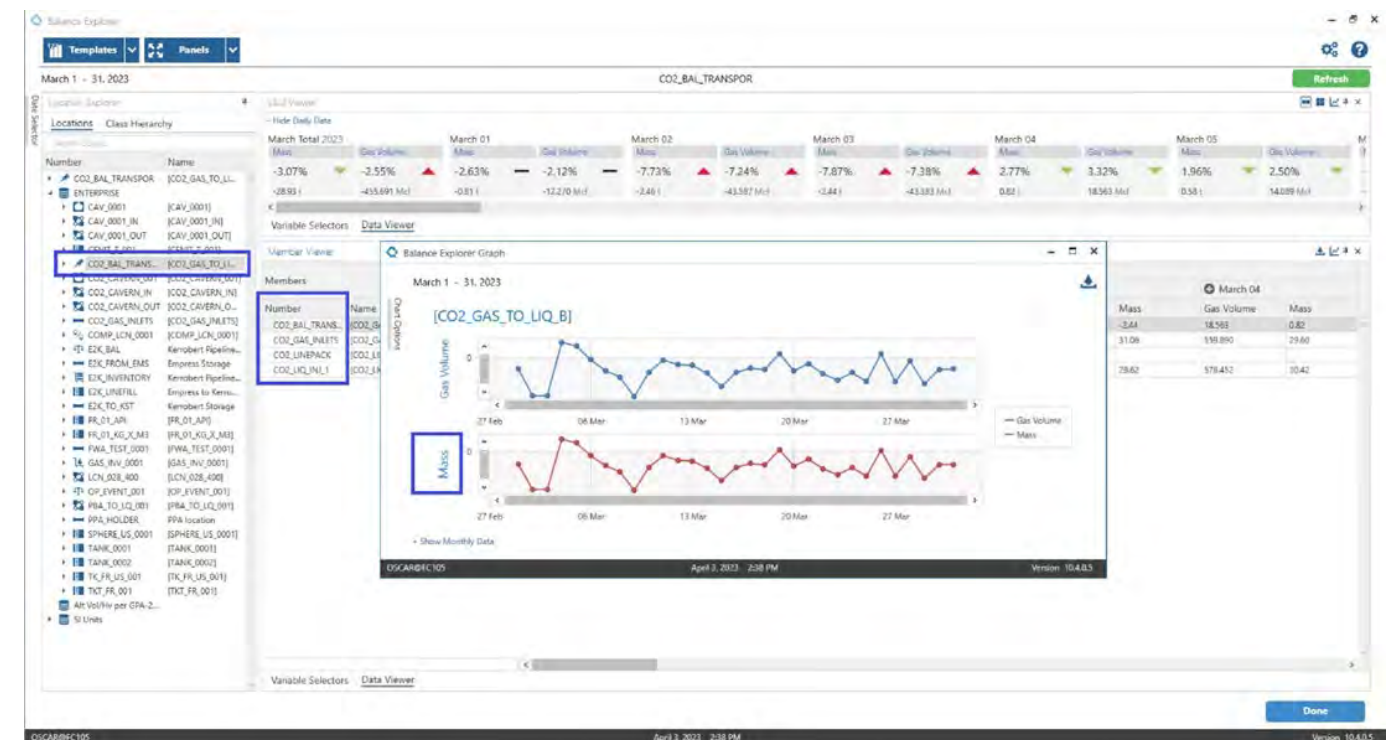

CO₂ Transportation and Injection Balance

Liquid Volume Statement - By Product

March 2023

Meter #: CO2_LIQ_INJ_1
 Meter Name: [CO2_LIQ_INJ_1]
 Product: CO2 - CSS
 Table: NIST 23 V9.0

Contract Hour: Midnight Pressure Base: 14.696 DMF: 1.0000 Meter Type: Coriolis
 Contract Day: 1 Temperature Base: 60.0 K-Factor: 1.0000 Calc. Method: API (Direct Mass)
 Mass %: CO2 99.739 N2 0.100 C1 0.095 C2 C2H4 C3 C3H6 IC4 NC4 C4H6 IC5 NC5 neo C6+
 Liq Vol %: 99.531 0.168 0.259

| Day | Meter Temp (°F) | Meter Pressure (psi) | Flowing Density (REL) | Pulses | Meter Factor | Mass (tonnes) | Base Density (REL) | Net Std.Vol (NSV) (bbl) | Summed Volume (bbl) | Net Allowable (bbl) |
|--------------|-----------------|----------------------|-----------------------|------------------|---------------|----------------|--------------------|-------------------------|---------------------|---------------------|
| 1 | 53.7 | 1244 | 0.8897 | 66,644 | 1.0025 | 29,850 | 0.8099 | 232.04 | 230.37 | 230.37 |
| 2 | 59.6 | 1248 | 0.8871 | 64,566 | 1.0025 | 29,360 | 0.8099 | 228.23 | 226.58 | 226.58 |
| 3 | 59.7 | 1248 | 0.8868 | 62,930 | 1.0025 | 28,820 | 0.8099 | 222.48 | 220.87 | 220.87 |
| 4 | 56.8 | 1250 | 0.8785 | 66,897 | 1.0025 | 30,420 | 0.8099 | 236.47 | 234.77 | 234.77 |
| 5 | 57.4 | 1248 | 0.8758 | 66,919 | 1.0025 | 30,430 | 0.8099 | 236.55 | 234.84 | 234.84 |
| 6 | 56.2 | 1249 | 0.8843 | 66,644 | 1.0025 | 29,850 | 0.8099 | 232.04 | 230.37 | 230.37 |
| 7 | 53.4 | 1244 | 0.8908 | 64,192 | 1.0025 | 29,190 | 0.8099 | 226.61 | 225.27 | 225.27 |
| 8 | 57.9 | 1249 | 0.8739 | 63,511 | 1.0025 | 28,880 | 0.8099 | 224.50 | 222.88 | 222.88 |
| 9 | 58.7 | 1242 | 0.8703 | 63,467 | 1.0025 | 28,860 | 0.8099 | 224.35 | 222.73 | 222.73 |
| 10 | 59.7 | 1245 | 0.8665 | 63,379 | 1.0025 | 28,820 | 0.8099 | 224.03 | 222.42 | 222.42 |
| 11 | 59.1 | 1244 | 0.8688 | 64,874 | 1.0025 | 29,500 | 0.8099 | 229.32 | 227.67 | 227.67 |
| 12 | 56.0 | 1244 | 0.8840 | 66,897 | 1.0025 | 30,420 | 0.8099 | 236.47 | 234.77 | 234.77 |
| 13 | 59.5 | 1246 | 0.8874 | 66,436 | 1.0025 | 30,210 | 0.8099 | 234.84 | 233.14 | 233.14 |
| 14 | 52.3 | 1250 | 0.8953 | 64,256 | 1.0025 | 29,220 | 0.8099 | 227.14 | 225.50 | 225.50 |
| 15 | 51.4 | 1245 | 0.8982 | 63,423 | 1.0025 | 28,840 | 0.8099 | 224.19 | 222.57 | 222.57 |
| 16 | 51.4 | 1243 | 0.8980 | 63,335 | 1.0025 | 28,800 | 0.8099 | 223.88 | 222.26 | 222.26 |
| 17 | 51.0 | 1250 | 0.8998 | 63,885 | 1.0025 | 29,050 | 0.8099 | 225.82 | 224.19 | 224.19 |
| 18 | 59.7 | 1250 | 0.8869 | 66,897 | 1.0025 | 30,420 | 0.8099 | 236.47 | 234.77 | 234.77 |
| 19 | 52.1 | 1245 | 0.8956 | 65,270 | 1.0025 | 29,680 | 0.8099 | 230.72 | 229.05 | 229.05 |
| 20 | 54.7 | 1246 | 0.8861 | 66,764 | 1.0025 | 29,900 | 0.8099 | 232.43 | 230.76 | 230.76 |
| 21 | 51.9 | 1241 | 0.8960 | 64,324 | 1.0025 | 29,250 | 0.8099 | 227.38 | 225.74 | 225.74 |
| 22 | 52.8 | 1244 | 0.8929 | 64,192 | 1.0025 | 29,190 | 0.8099 | 226.61 | 225.27 | 225.27 |
| 23 | 56.7 | 1245 | 0.8823 | 64,104 | 1.0025 | 29,150 | 0.8099 | 226.60 | 224.96 | 224.96 |
| 24 | 54.8 | 1246 | 0.8856 | 63,181 | 1.0025 | 28,730 | 0.8099 | 223.34 | 221.72 | 221.72 |
| 25 | 54.5 | 1247 | 0.8871 | 65,894 | 1.0025 | 29,950 | 0.8099 | 232.62 | 231.14 | 231.14 |
| 26 | 58.2 | 1241 | 0.8800 | 64,876 | 1.0025 | 29,410 | 0.8099 | 228.82 | 226.97 | 226.97 |
| 27 | 56.0 | 1241 | 0.8808 | 66,764 | 1.0025 | 29,900 | 0.8099 | 232.43 | 230.76 | 230.76 |
| 28 | 59.1 | 1248 | 0.8993 | 66,567 | 1.0025 | 30,270 | 0.8099 | 235.31 | 233.61 | 233.61 |
| 29 | 56.0 | 1244 | 0.8846 | 66,578 | 1.0025 | 29,820 | 0.8099 | 231.81 | 230.13 | 230.13 |
| 30 | 57.0 | 1243 | 0.8772 | 64,742 | 1.0025 | 29,440 | 0.8099 | 228.85 | 227.20 | 227.20 |
| 31 | 56.3 | 1246 | 0.8838 | 65,100 | 1.0025 | 29,630 | 0.8099 | 230.33 | 228.67 | 228.67 |
| Total | 56.7 | 1246 | 0.8820 | 2,012,331 | 1.0025 | 915,000 | 0.8099 | 7,113.30 | 7,061.94 | 7,061.94 |

FLOWCAL by Quorum Software © Quorum Software. All Rights Reserved. Print Date: 04/03/2023 15:10 Page 1

Dense phase CO₂ volume statement

In summary, FLOWCAL enables CCS operators to review, correct, and account each CO₂ molecule whether it is in gas or dense phase, in the pipeline or in underground storage. FLOWCAL can manage CO₂ custody transfer data, balance the captured versus the injected CO₂, keep track of CO₂ inventories in the pipe and underground, and provide a holistic view of the CO₂ moved across the

CCS operation. System balancing can be managed from gas volume balance, liquids volume balance, and mass balance perspective providing a bird's eye view of the entire CCS system. Please see our website: <https://www.quorumsoftware.com/solutions/measurement/gas-liquid-measurement/>

FULL VALUE CHAIN





CONTACT

Email: daniel.tay@my.abb.com

Web: www.new.abb.com



ABB BALANCE OF OPERATIONS FOR CCS NETWORKS ABB PROCESS AUTOMATION

SUMMARY

ABB is a prominent provider of electrification, controls/automation, telecommunication, and digital (ECTD) solutions to energy industries, including carbon capture and sequestration (CCS). As a technology partner to the energy industry, ABB has advanced its comprehensive sustainability portfolio by integrating cutting-edge

technology known as ABB Balance of Operations for CCS networks. Our patented product is tailored specifically to enhance the efficiency and management of CCS network operations from the emitters through to and including the subsurface storage formations, encompassing the complete network lifecycle.

BENEFITS

ABB CCS Balance of Operations embodies an end-to-end digital solution with energy optimization capabilities, focused on ensuring safe, reliable, and efficient operation of CCS networks with the following core functionalities:

- Leading-edge modelling of CO₂ processes and impurities
- Subsurface geological lifecycle modelling for CO₂ dispersion
- Autonomous and optimized operation for real-time transient response
- Smart heating, cooling and energy-optimized compressor and pump control
- CO₂ injection profile management
- Real-time CO₂ corrosion prediction
- Training, simulation, and 'look-ahead' or 'what-if' scenario analysis for planning
- Enablement for autonomous operations

DESCRIPTION

Industrial carbon dioxide (CO₂) emissions are a significant contributor to global warming and climate change. According to the Intergovernmental Panel on Climate Change (IPCC), one of the key measures for countries to accelerate their efforts toward achieving net zero emissions in accordance with the Paris Agreement, is the adoption and implementation of carbon capture and storage (CCS) technologies. A crucial aspect of a CCS system is the design and operation of its network infrastructure which encompasses gathering and export pipelines, storage facilities, compressors, heaters, coolers, pumps and injection systems for safe and reliable transport and storage of CO₂ in subsurface formations.

However, transitioning from the design phase to the operational phase of any CCS network project poses significant challenges especially as the transportation and permanent storage of CO₂ is different when compared to hydrocarbons specifically around understanding CO₂ corrosion and its thermodynamics. To date, most CO₂ sequestration experiences has been around enhanced oil and gas recovery (EOR/EGR). The challenges are made more difficult with the implementation of hub & cluster type networks. The complexity arises with having multiple emitters and sources of CO₂ flowing into the network with varying pressures, temperatures, and impurity composition. Therefore, there is an identified need for a comprehensive modelling solution of the entire value chain of a CCS network, which would not only assist in the design phase as a proof-of-concept tool and provide detailed simulations, but also deployed as a predictive and real-time operational solution throughout the entire lifecycle of the network. Such a digital model would help reduce investment costs, operational expenditures and mitigate operational risks.

To address this knowledge gap in the CCS segment, ABB has developed an integrated digital solution called ABB Balance of Operations which harnesses the capabilities of digital twins for different aspects of a CCS network. This digital solution specifically focuses on two important parts of a CCS network, namely the transportation and permanent storage of CO₂.

During operations, on the above-surface element, this solution is capable of managing CO₂ flow assurance and conduct CO₂ thermodynamic modeling in real-time, as well as respond to the transients and interruptions within the network in real-time with regards to loss of emitter(s), well shut-ins, as well as pressure, temperature and flowrates fluctuation to provide responsive and flexible operation of the CCS cluster network. It is also able to analyze composition of impurities in individual CO₂ streams from multiple emitters, calculate the blended emission composition from multiple emitters, and compute to predict corrosion factors, ensuring safety and reliability of the network infrastructure and its operation.

On the subsurface element of the CCS network, this solution is able to model the subsurface formation in 3D and in real-time in terms of its capacity, containment and injectivity. This allows for the availability of real-time data and parameters such as injection pressure, temperature and flowrates to be input into an optimization system.

A digital optimizer then computes and provides optimized setpoints for key operational aspects such as compression, heating, cooling and tight injection profiles according to the operational philosophy across multiple injection wells with varied subsurface pressures. The solution is also capable of modeling and forecasting the dispersion of CO₂ within the subsurface formation throughout the lifecycle of the network. This optimization process ensures minimization of energy consumption and ensures high availability of the network.

ABB Balance of Operations for CCS networks is an integrated holistic digital solution which ensures operational flexibility and reliability through the entire operational lifecycle of a CCS network. It caters to the complexities of a CCS network by providing capabilities such as full-chain modeling of the CCS network, analysis of CO₂ flow streams in terms of impurity composition, calculation of blended CO₂ emission composition, computation and prediction of corrosion factors, modeling of subsurface geological formations, and optimization of energy consumption through compression, pumping, heating, cooling and injection rates. This solution aims to ensure high operational availability, infrastructural safety, and de-risk CCS network operations whilst optimizing operational costs.



AspenTech Sustainability Pathway: CCS/CCUS

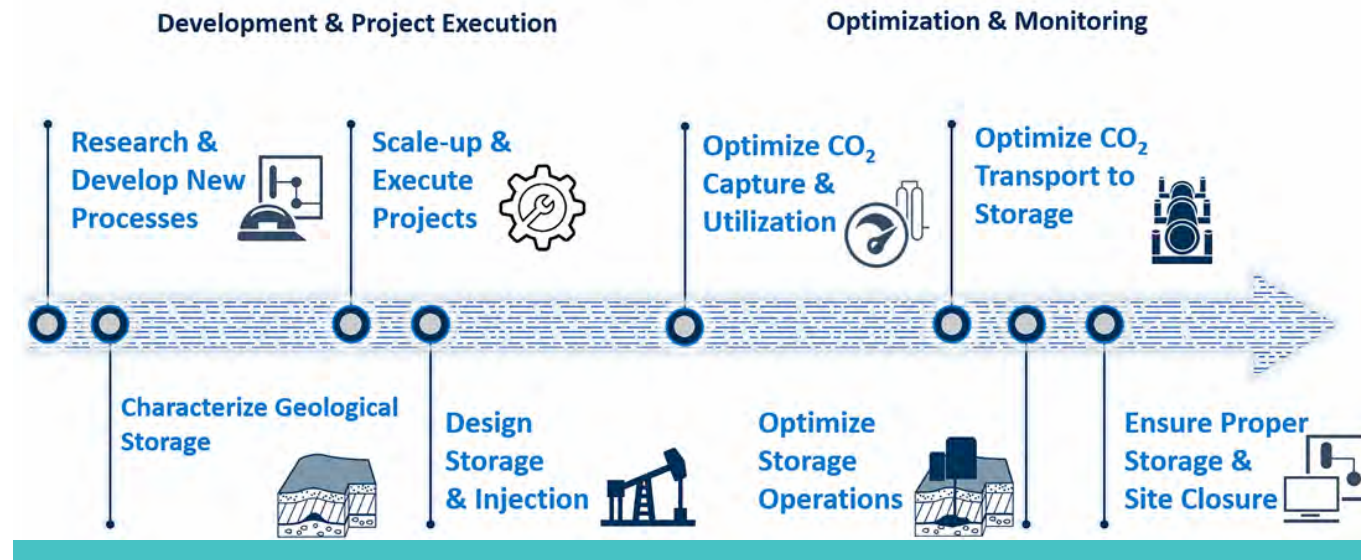

CARBON CAPTURE AND STORAGE SOLUTIONS ASPEN TECHNOLOGY

SUMMARY

Digital technologies are crucial enablers for continuous innovation, economic scale of technologies, accelerated implementation, and complete confidence in geological CO₂ storage.

AspenTech is an industrial software company for capital-intensive industries with a long history of innovation that started over 40 years ago with the first process flowsheet simulator. AspenTech digital portfolio provides a comprehensive, holistic approach to asset optimization across design, operations and maintenance.

For the carbon capture value chain, an end-to-end solution

includes optimization of capture, transportation and storage. AspenTech process simulation software already has a strong track record of helping companies improve operational efficiency and reduce emissions and is even more crucial to CCUS.

The powerful combination of AspenTech breakthroughs in process simulation, subsurface geophysical and geological modeling, AI-powered hybrid modeling, process optimization software and digital grid management can deliver results at scale—both economically and at an accelerated pace to meet the requirements of industrial carbon mitigation.

BENEFITS

- Drive innovation in the development of new carbon capture technologies
- Evaluate risk in CCS systems to make informed investment decisions across the value chain
- Reduce capital and operational expenditures in carbon capture processes with rigorous process simulation
- Accelerate cost-effective commercialization and scale-up of carbon capture processes with optimized process designs
- Screen storage/sequestration candidates & select storage locations by evaluating capacity, containment and site ability for injection and monitoring performance
- Optimize injection conditions during storage and track CO₂ movements in the subsurface to demonstrate regulatory conformance

DESCRIPTION

Across the carbon capture value chain, digital solutions for capture, transportation and storage can address the key challenges to successful commercialization and wide-scale deployment of CCUS, by helping to reduce costs, minimize risks and ensure confidence in long-term solutions. Additionally, risk and reliability software evaluates project plans and economic feasibility by analyzing the effect of factors such as the equipment reliability and capacities, operations logic, storage limits, maintenance practices, logistics alternatives, weather, and market conditions. This dynamic, event-driven modeling technology can provide an accurate prediction of future performance to justify investment and operation decisions that will minimize the risks and will maximize profits across the asset lifecycle.

Digital Solutions from AspenTech can be used across the value chain by different stakeholders to:

- Prioritize investment options
- Help to make technology more economic to deploy it at a wider scale
- Accelerate project execution
- Improve efficiency in operations

RESEARCH & DEVELOPMENT OF CAPTURE PROCESSES

Digital technologies, using well-known process simulators Aspen Plus® and Aspen HYSYS®, can help to perform technical and economic analysis through rigorous modeling of carbon capture or conversion of CO₂ into valuable products, by representing the complex chemistry and thermodynamics.

GEOLOGIC CHARACTERIZATION

Characterization of geologic storage candidates with efficient subsurface studies to confirm technical and economic feasibility, disclose technical details of the proposed site and enhance confidence to support permit applications.

PROJECT SCALE-UP AND EXECUTION

AspenTech's Concurrent Engineering solution leverages digital technologies that improve collaboration between Licensors, Engineering & Construction companies, and owner-operators. Models used on previous technology development and R&D stages provide early visibility to help improve CAPEX allocation across any future projects and eliminate risks. Digital tools provide insights to size and select equipment and identify the need for corrosion or other types of sensors that could reduce the CAPEX needed.

Scale-up uncertainties can be further evaluated with Aspen Fidelis™ to consider alternative processes and prioritize capital options. This dynamic, event-driven modeling technology can provide an accurate prediction of future performance to justify investment and operation decisions that will minimize the risks and will maximize profits across the asset lifecycle.

CAPTURE TECHNO-ECONOMICS

Process modeling can further optimize capture processes and improve economics. AspenTech's integrated economics, energy and emission analysis, enables iteration of process configurations, to reduce costs and carbon footprint, identifying the right tradeoff between capture efficiency and energy consumption.

In December 2022, AspenTech announced a partnership with Saudi Aramco to provide a unique, integrated modelling and optimization solution that will enable capital intensive industries to address the identification of the most promising carbon capture and utilization paths by simultaneously considering economics, process design and operations constraints and CO₂ reduction. The goal of this innovation is to enable businesses to make evidence-based decisions in support of adopting carbon management strategies that optimize and accelerate sustainable operations.

CARBON CAPTURE OPERATIONS

Models from the design stages can be used for high-fidelity Operator Training Systems to help staff be prepared once the process is up and running. In addition to that, advanced process control technologies like Aspen DMC3, can improve the stability of the process, and reduce energy use in key unit operations.

LONG-TERM MONITORING OF GEOLOGICAL STORAGE

In the long term, during operation of the carbon management system and at the post-closure stage, digital technology is crucial to enable reliable, transparent and auditable records of the performance of the carbon storage asset. Time lapse (4D) seismic monitoring allows the imaging of the growth of the CO₂ plume in the reservoir and helps demonstrate both containment and conformance. Today's AspenTech Subsurface Science & Engineering provides the tools to analyze and interpret monitoring measurements and to update performance prediction through 3D model calibration.

Integrated digitalization strategies for CCS, and related sustainability initiatives, will ensure long-term business resilience during the demanding and volatile Energy Transition. Choosing the right partner to guide your journey will be critical to tackle the magnitude of this challenge and the transformation required. AspenTech understands the value of partnership and the deep and lasting bonds that come from continuous engagement, working side-by-side with customers to identify new applications as they adapt to changing market demands while also ensuring sustainability progress.



OFFSHORE FLEXIBLE PIPES BAKER HUGHES

SUMMARY

Subsea CCS projects require pipelines for transportation of CO₂ to the reservoir. Key requirements of these pipelines include technical capability, cost-effectiveness and risk reduction. Baker Hughes unbonded flexible pipes have a proven track record in CO₂-rich applications that address these technical requirements. Baker Hughes' flexible pipe product has the potential to offer significant cost and risk benefits to a CCS project compared to alternative options such as rigid pipes.

BENEFITS

- Proven capability for high-pressure CO₂ transportation using standard materials and product design
- Project schedule is hugely benefited when compared to rigid alternatives
- Enabling technology for shallow-water dynamic CO₂ risers

DESCRIPTION

Baker Hughes has been supplying unbonded flexible pipe to the offshore oil & gas industry for more than 30 years, supporting the development of such projects that face some of the harshest conditions in the world. An unbonded flexible pipe is made up of a series of polymer and metallic layers that are uniquely configured to suit each project's specific requirements.

The traditional oil & gas industry is witnessing a remarkable surge in demand for CO₂-compatible pipelines, primarily fueled by the unique challenges posed by CO₂-rich pre-salt reservoirs in Brazil. In these projects, CO₂ stripped from the pre-salt fields' production fluids is reinjected into the reservoirs at high pressures.

Baker Hughes has undertaken significant research and development over more than five years to support the use of its conventional flexible pipe products in CO₂-rich applications. This research, which includes small-, mid- and full-scale tests, has led to a detailed understanding of the critical design parameters for transporting CO₂. A review by an Independent Verifying Authority has led to an approved 'safe envelope' of operating conditions under which no failure modes, including stress corrosion cracking, will occur.

Baker Hughes' proven expertise in CO₂-rich applications has positioned the company as a leading supplier of flexible pipes, with more than 70km of such pipes already installed.

These CO₂-compatible products leverage the same set of standard materials and manufacturing techniques employed in more traditional applications, ensuring consistent quality and performance across the board.

Based on the product's capability and track record, Baker Hughes' flexible pipes are equally suitable for use in CCS applications and there are clear value propositions for this product. For example, shallow water CCS dynamic applications necessitate a technology that can withstand CO₂ and a high-fatigue environment. Only an unbonded flexible pipe has a proven track record in both.

When used as infield flowlines, flexible pipes can lead to a lower total-installed cost than rigid pipes. Furthermore, flexibles remove the need for rigid jumpers, which require metrology and fabrication before installation. This hugely benefits the schedule at the most critical time – shortly before start-up.

Baker Hughes remains committed to providing cutting-edge, reliable solutions for the offshore oil & gas industry, while simultaneously addressing the growing need for CO₂-compatible pipelines in CCS applications. By consistently delivering high-quality, innovative products, Baker Hughes cements its position as a trusted partner, helping to shape a sustainable future for the energy sector.

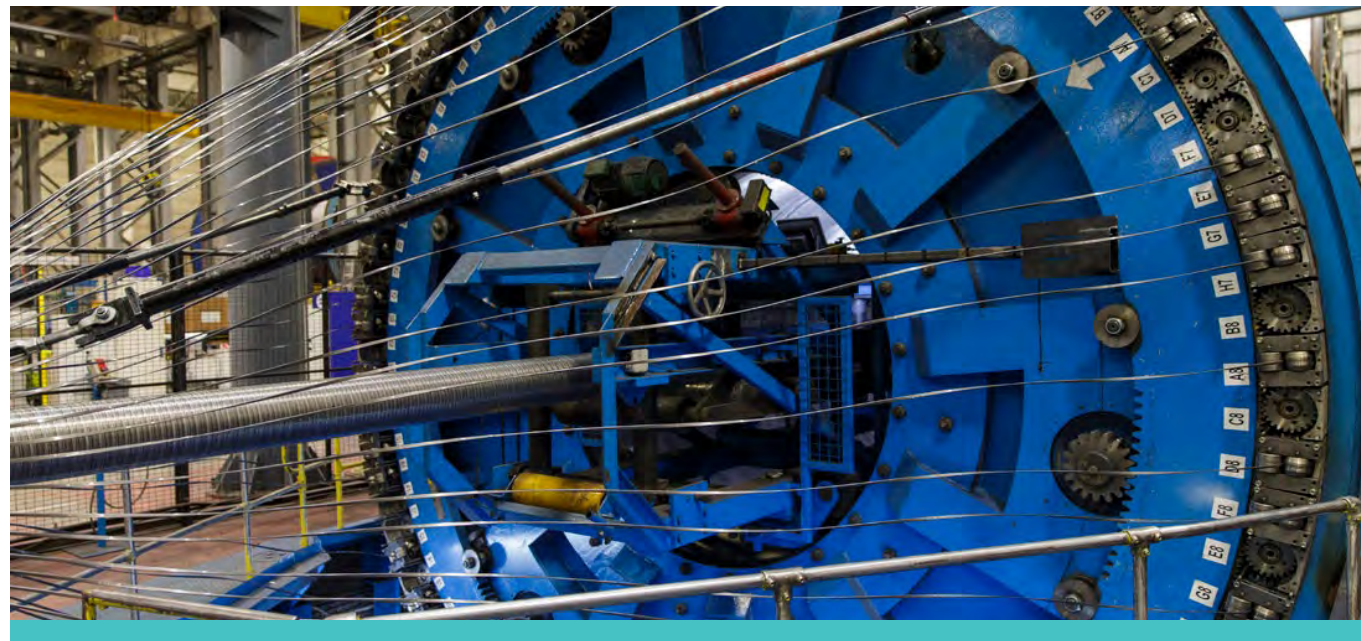

REGENERATIVE FROTH CONTACTOR BAKER HUGHES

SUMMARY

Baker Hughes has acquired a Canadian start-up, Industrial Climate Solutions (ICS), to further strengthen engineering technology developments through process intensification. The technology provided by ICS is the Regenerative Froth Contactor (RFC) equipped with Corrugated Screen Packing (CSP). The RFC operates in co-current flow under the pulse regime generated by the gas and liquid phases that flow through the CSP packing, a static equipment. The RFC

provides an increase of effective mass transfer surface that reduces the required packing volume, within admissible pressure drop values for the process. The technology is solvent-agnostic and has been validated at lab scale. ICS is currently conducting the implementation for post-combustion carbon capture applications within Baker Hughes portfolio.

BENEFITS

- Higher mass transfer rate
- Significant absorption tower height reduction
- Significant absorption tower cross-sectional area and footprint reduction
- Fouling and salts deposition resistance
- Limited impact of high viscosity on mass transfer rate

DESCRIPTION

The Regenerative Froth Contactor (RFC) provided by ICS is an innovative gas/liquid absorption co-current contactor system equipped with the Corrugated Screen Packing (CSP) that offers promising reductions in equipment size versus conventional absorbers. The RFC absorber represents a cutting-edge technology. It is static equipment, having no moving parts, and operates in a downward gas- liquid 'co-flow' configuration, with pulse regime hydrodynamic condition. While conventional absorbers work with a thin film of liquid over the packing itself, the CSP is made of convoluted screens that maximize the solvent pulsing effect while minimizing the metal packing material; by inducing the RFC to operate under a froth condition in two phase flow, the diffusivity film over the traditional packing surface is replaced by millions of bubbles and droplets in the volume of the tower. These bubbles are created as bands of froth collapse and are regenerated. The liquid and gas phases enter the tower co-currently from the top, flow through the absorber in pulsing regime and are disengaged at the bottom of the tower. The pulse flow is not imposed by a mechanical stimulation but set up as a purely hydrodynamic multi-phase phenomenon depending on the phases flow rates and the CSP design. The gas passes through multiple zones of froth along the

absorber and gas components gets absorbed into the solvent.

In carbon capture application, the CO₂ will be transferred from the gas into the liquid phase in the froth present throughout the whole volume of the column. The RFC absorber/reactor design enables the system to accommodate high gas flow rates and liquid/gas ratios at acceptable back pressure and without encountering flooding in the column. RFC systems can also be used in processes with precipitating solvents or high levels of entrained solids, leading to 3-phase contactors. There is minimal-to-no fouling or additional pressure drop penalty with RFC technology, even under high particulate loads and high viscosity.

Based on the selected gas/liquid system's physical properties (e.g. viscosity, presence of solid precipitation), the geometry of the CSP packing can be selected to enforce a coarser/thinner froth.

Applications of the RFC technology can be used across various carbon capture platforms, ranging from natural gas treatment, post-combustion capture, and air pollution control, e.g., indoor air quality management, direct air capture





CHILLED AMMONIA PROCESS BAKER HUGHES

SUMMARY

The Chilled Ammonia Process (CAP) was developed to address the challenges of removing carbon dioxide from low-pressure flue gases, which were generated by fossil-fuel-based power plants and industrial emissions points, such as coal-fired power plants, waste-to-energy power plants, biomass power plants, cement plants, refineries, and petrochemical complexes.

CAP is a post-combustion carbon-capture process that uses a non-proprietary solvent formulation based on ammonia. Ammonia is a low-cost, inorganic commodity chemical, readily available on the global market from multiple sources and not bound to any specific supplier. It is also stable, tolerant to flue gas contaminants and typically exhibits very low and controllable loss in the CAP process. Moreover, green ammonia (produced from green hydrogen) could be used instead of conventional ammonia in the CAP process.

Amine-based solvents have a tendency to degrade as a result of exposure to hot environments (thermal degradation), in the presence of oxygen (oxidative degradation) and in acid gas reactions (such as NO_x). The degradation results in a reduction of performance,

solvent loss, equipment corrosion and the generation of volatile degradation compounds that are emitted into the treated flue gas, including nitrosamines, which are known carcinogens. Such degradation phenomena are absent for CAP, as the process uses an ammonia-based solvent, which is inorganic. CAP has the added advantage of being able to regenerate CO₂ at elevated pressure, resulting in reduced energy costs to liquefy or further compress the CO₂ downstream.

CAP has been validated at several test facilities with a design capacity of up to 100 ktpa CO₂, treating flue gases generated by oil boilers, coal boilers and industrial off-gases. A CAP plant designed to capture up to 80 ktpa CO₂ has been operated at Test Centre Mongstad (TCM) in Norway for 2 years, where it demonstrated low specific thermal energy consumption of 2.6 GJ/ton CO₂ on refinery cracker offgas (12.5 -16.0% CO₂). The testing at TCM also demonstrated CAP's ability for quick start-up, low ammonia emissions, high CO₂ product purity and meeting targeted CO₂ capture rates.

BENEFITS

- Demonstrated low specific thermal energy consumption of 2.6 GJ/ton CO₂
- Uses ammonia, a commodity chemical that is easily procured and not bound to a specific supplier
- Stable reagent. Unlike amine-based solvent systems, it does not suffer from thermal and oxidative degradations
- Flexible for process integration. Allows efficient-direct high temperature waste heat utilization or direct electrical heating without the degradation of solvent performance
- Tolerant towards oxygen in flue gas and towards contaminants such as SO_x and NO_x
- Produces less harmful emissions and potentially useful by-products
- Regenerates CO₂ at high purity (> 99.5%) at elevated pressure, thus requiring less compression energy for the downstream CO₂ product

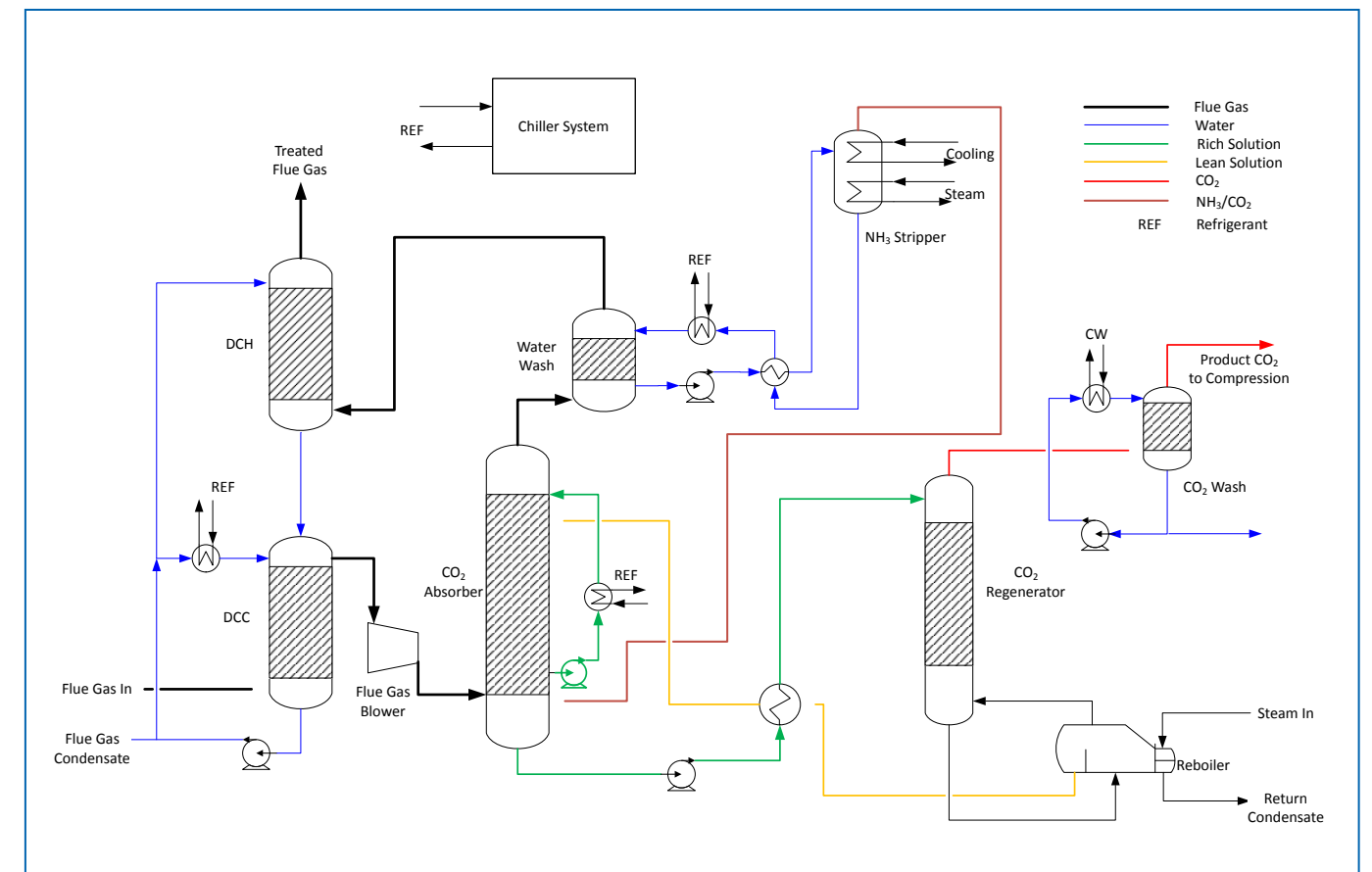

DESCRIPTION

The Chilled Ammonia Process (CAP) uses an ammoniated aqueous carbonate solution to absorb CO₂ from the flue gases at ambient pressure and low temperature. Unlike other technologies, the functionality of the ammonium solution is not affected by oxygen and easily purged of heat stable salts formed by trace acidic components, which may pass dedicated flue gas preconditioning steps. Moreover, since its gaseous emissions and liquid waste streams are non-toxic, no additional treatment facilities are required.

A simplified process flow diagram of the CAP technology is shown in the accompanying figure and the process can be described as follows.

Inlet flue gas first undergoes cooling via a direct contact cooler (DCC) that enables the contact of gas with cooling and chilled water to lower the flue gas temperature to a suitable level (typically below 15 °C), which is needed for the CO₂ absorption process and water balance. Most of the water vapour contained in the flue gas is removed in this step, which reduces the volumetric gas flow and increases the CO₂ concentration. For conventional amine-based solvents, a flue gas pre-treatment step is required, which is typically integrated with the DCC to reduce NO_x, SO_x and other contaminants in the flue gas to very low levels to decrease degradation and formation of heat-stable salts when the flue gas interacts with the solvent. However, for CAP, this pre-treatment step is typically not required as the ammonia-based solvent is able to tolerate these flue gas contaminants. Strong acids such as SO_x react with ammonia and form heat-stable salts, which are withdrawn from the system as an aqueous by-product.

Cooled flue gas from the DCC enters the bottom of the absorber column, where it is washed counter-currently with lean ammonia-based solvent (orange line). CO₂ is selectively removed from the flue gas in a chemical absorption process using the alkaline lean solvent. The lean solvent is a solution comprising ammonia, water and CO₂ where different species (ammonium carbamate, ammonium bicarbonate, ammonium carbonate and a

limited amount of free ammonia in an aqueous solution) are in equilibrium. The dissolved ammonia species react with CO₂ from the flue gas in the absorber by shifting the species' equilibria towards bicarbonate. The CO₂-rich solvent (green line) leaves at the bottom of the absorber and is sent to the regenerator section, where it is heated to a temperature high enough for CO₂ to be released from the solvent. A reboiler located at the bottom of the regenerator column provides the heat to the solvent. The heating source is typically steam, although hot oil or heat from a direct-fired or electric heater can also be used due to the absence of thermal degradation.

Heat is imparted to the solvent to shift the equilibria to ammonia-rich species releasing the absorbed CO₂, which leaves at the top of the regenerator column. Compared to the amine-based post-combustion technologies that regenerate CO₂ at near atmospheric pressure, CAP regenerates CO₂ at an elevated pressure (14 bar - 25 bar(a)), which reduces the downstream compression power requirements.

Regenerated lean solvent (orange line) is returned to the absorber after undergoing cooling through heat exchange with the cold rich solvent in the lean-rich heat exchanger, which simultaneously heats the rich solvent. This is an important heat integration step that significantly reduces the reboiler heat requirement.

Treated flue gas exiting the top of the absorber column contains residual CO₂ and ammonia, which is recovered with a water wash step to prevent unacceptable emissions of ammonia into the atmosphere. After the water wash step, the flue gas is routed to a flue gas heater. A guard system is integrated with the flue gas heater, which relies on the injection of sulfuric acid to neutralize any residual ammonia, converting it into ammonium sulphate. The flue gas is reheated with warm water condensed from the DCC, which serves to raise the temperature of the final treated flue gas to a temperature high enough to be released into the stack and to optimize the water balance of the system.





MIXED-SALT PROCESS BAKER HUGHES

SUMMARY

Baker Hughes uses the Mixed-Salt Process (MSP) for CO₂ capture under license from SRI International. SRI International received support from the US Department of Energy's Office of Fossil Energy and National Energy Technology Laboratory (NETL) for the development of this technology.

MSP is a post-combustion carbon-capture process that uses a novel solvent formulation, which is based on potassium carbonate and ammonium salts. Both chemicals are low-cost, inorganic commodity chemicals, and readily

available on the global market from multiple sources. The inorganic solvent used by MSP is tolerant to flue gas contaminants (such as SO_x, NO_x, and O₂), unaffected by thermal and oxidative degradation, results in lower emissions, lower toxicity, and higher CO₂ regeneration pressure compared to conventional amine-based solutions. MSP has been demonstrated at the capacity of 0.25 tpd at the SRI campus in Menlo Park, USA. A 10 tpd pilot-scale plant to demonstrate the MSP technology at the University of Illinois is currently in the design phase.

BENEFITS

- Reduced reboiler energy consumption of 2.0 – 2.3 GJ/ton CO₂
- Uses inexpensive, industrially available chemicals (potassium and ammonium salts)
- Stable reagent. Unlike amine-based solvent systems, it does not suffer from thermal and oxidative degradation
- Tolerant towards oxygen in flue gas and to contaminants such as SO_x and NO_x
- Regenerates CO₂ at elevated pressure, thus requiring less compression energy for the downstream CO₂ product
- Reduced auxiliary electricity loads

DESCRIPTION

MSP is a post-combustion technology that is applicable to a wide range of flue gases. It uses a blend of ammonium and potassium-based salts to absorb CO₂ from flue gases at ambient pressure and temperature. The stability of the inorganic solvent used by MSP's ammonium solution is not affected by oxygen and shows high tolerance to acidic trace components present in the incoming flue gas. The process is characterized by very low emissions and produces little-to-no toxic waste.

A simplified process flow diagram of the MSP technology is depicted in the accompanying figure and the process can be described as follows.

Inlet flue gas first undergoes cooling to 20 - 30 °C in a direct contact cooler (DCC) and subsequently enters Absorber 1, where it contacts the mixed salt solvent counter-currently. The mixed salt solvent in Absorber 1, which has a higher concentration of ammonium-based species than potassium-based species (high ammonia/potassium ratio), performs the bulk removal of CO₂, absorbing 60-80% of the CO₂ in the flue gas. The remaining CO₂ is absorbed in Absorber 2, which operates with the mixed-salt solvent with a lower ratio of ammonium-based species to potassium-based species than that of the solvent feed of Absorber 1. Absorber 2 performs the trim removal of CO₂ to achieve an overall CO₂ capture rate of more than 90% and reduces the ammonia slip from Absorber 1. A water wash located at

the top of Absorber 2 further reduces the ammonia content in the treated flue gas to ensure that it meets the ammonia emission limits.

Both absorbers operate with liquid recycle using heat exchangers to remove the heat of reaction and keep the solution at the optimum temperature for efficient absorption and minimum ammonia slip. The CO₂-rich solvent collected from the absorbers is sent to the regenerator for regeneration via an integrated rich-lean heat exchanger network that is designed to recover sensible heat.

Heat is supplied to the regenerator via a reboiler located at the bottom of the column. The increase in temperature releases CO₂ as a gas and regenerates the mixed-salt solvent to be returned to Absorber 1 and Absorber 2. CO₂ is released at an elevated pressure of 10 - 20 bar(a) from the regenerator column, which serves to reduce the downstream CO₂ compression power requirements.

The CO₂-lean mixed salt solvent is drawn from the lower-middle stage of the column and sent back to Absorber 1 to perform bulk CO₂ removal. Near the bottom of the regenerator where the temperature is higher, ammonia is vaporized, resulting in a lean solvent with low ammonia/potassium ratio, which is returned to Absorber 2 where it performs the trim removal of CO₂ and reduces ammonia losses.

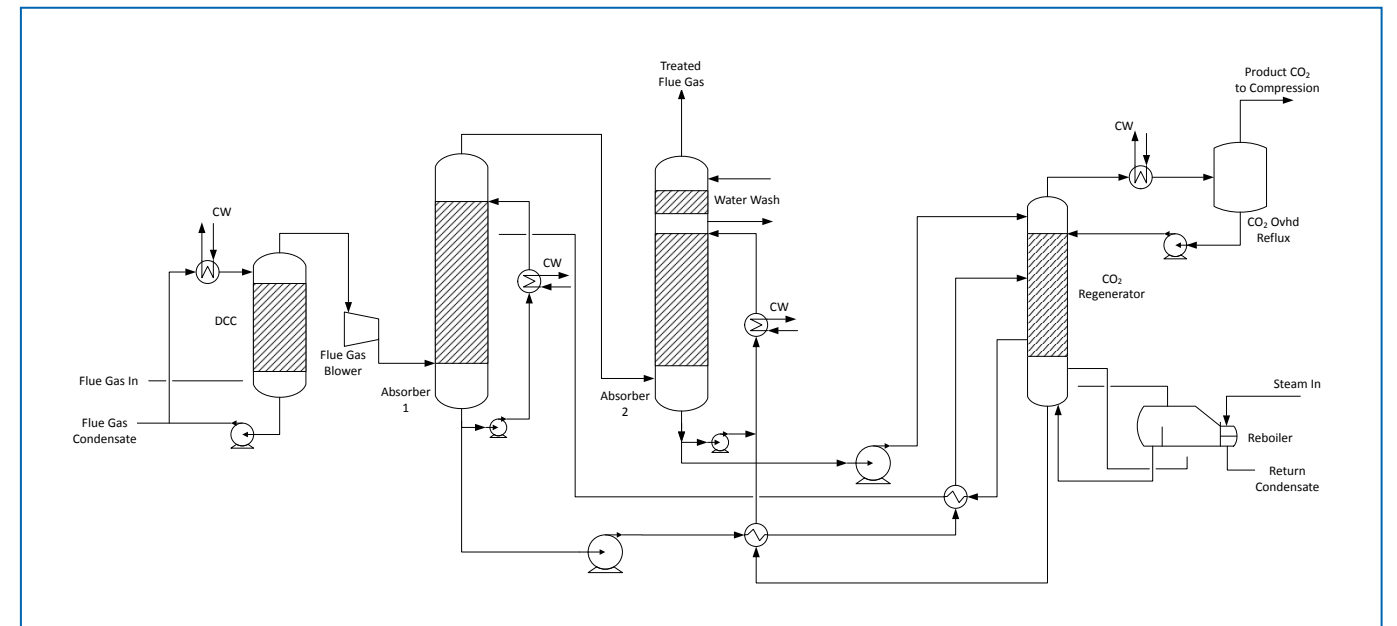



COMPACT CARBON CAPTURE (CCC) BAKER HUGHES

SUMMARY

Baker Hughes acquired Compact Carbon Capture (CCC), a pioneering technology development company based in Bergen, Norway, that specializes in compact carbon capture solutions. CCC employs the rotating packed bed technology, a novel process intensification that utilizes centrifugal acceleration to intensify mass transfer, thereby reducing the equipment size and cost. CCC's technology is solvent-agnostic and in principle, can be applied to any solvent developed for post-combustion carbon capture.

Using its rotating packed bed technology, CCC drastically

increases the vapor-liquid contact area, overcoming the traditional hydraulics limitations. Compared to traditional solvent-based systems using static equipment, CCC's enhanced mass transfer results in reduced residence time in both the absorber and the regenerator, thereby requiring much smaller equipment.

CCC is currently validated at the pilot scale at Equinor's test facilities (PLAB) in Porsgrunn, Norway. Steps for further advancement are ongoing, with a demonstration plant at the 15 tpd scale currently in the engineering stage.

BENEFITS

- Up to 75% reduction in the overall size of the capture plant compared to conventional technologies
- Up to 50% reduction in capital expenditure compared to conventional technologies
- The possibility to reduce operating expenses significantly by using new, viscous, and efficient solvents
- Reduced lead time through standardized and containerized production, design thinking for simplified logistics, and decreased demand for civil works
- Modular scalability to increase the deployment speed of CO₂ capture equipment. For example, it is possible to invest in partial capture right away and increase the capture capacity at a later stage.

DESCRIPTION

Compact Carbon Capture has transformed the process equipment used in post-combustion carbon capture by introducing rotation and high G-forces to capture CO₂. The G-forces are created in several cross-flow rotating packed beds. CO₂-lean solvent is distributed from the inner axis and horizontally flung outwards in the direction of the wall of the column, while the flue gas moves vertically from the bottom to the top. Mass transfer takes place between the flue gas and the solvent in a cross-flow type arrangement.

Due to the rotation of the packed bed within the column that induces high centrifugal forces (60-100 G-force), the solvent is accelerated when it hits the packing structure, forming small droplets. This generates a large vapor-liquid contact area compared to traditional static mass transfer technology that rely on gravity. The larger contact area between gas and liquid results in a faster mass transfer of CO₂ from the flue gas into the solvent droplets, resulting in a much shorter absorber column height compared to conventional, static absorber columns.

The high G-forces allow for the application of highly viscous solvents that improve the process efficiency. Higher solvent concentration results in higher absorption rates. When this is combined with the compactness introduced by the process intensification, a considerably lower solvent volume is needed, and the pump capacity needed for solvent transfer is reduced.

The compact stripper is a combined reboiler and desorber unit that can operate at higher pressures and handle highly viscous solvents. High-speed rotation of the stripper unit introduces turbulence and high G-force to the solvent regeneration, which are advantageous for mass and heat transfer, resulting in very compact equipment. The rotating bed desorber/stripper can be described as a lightweight pressurized shell-and-tube heat exchanger where the "hot-side" tube bundle rotates to generate the centrifugal force required to produce small solvent droplets. Instead of a static regenerator column with attached reboiler in a conventional solvent-based system, CCC™ will have a single compact rotating bed/flash drum that both heats the rich solvent and flashes off CO₂ to generate a high purity (>99%) CO₂ product stream.

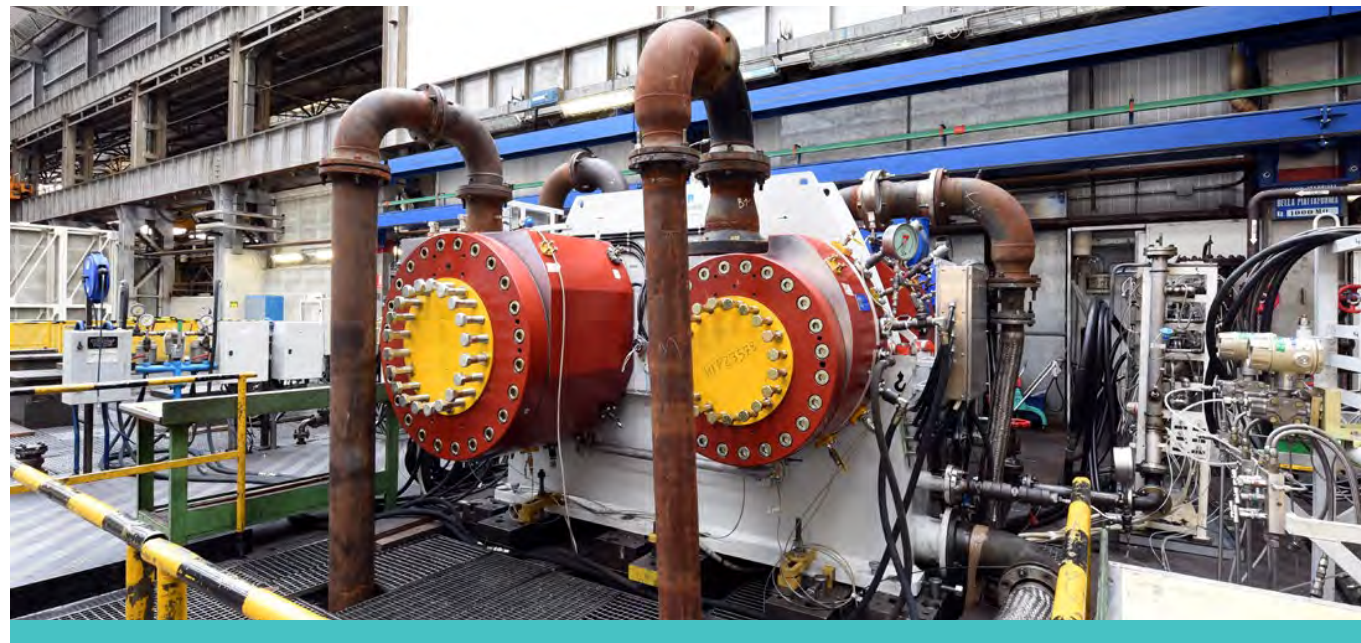

TRANSPORTATION BAKER HUGHES

SUMMARY

Leveraging its extensive domain expertise in compression and pumping technologies from decades of experience in related areas such as urea and liquefied natural gas, Baker Hughes has the comprehensive capabilities to make the compression of CO₂ safer, easier and more cost-effective for CCUS applications. Baker Hughes has focused its attention on customizing complete compression trains suited for the unique characteristics of CO₂ so that these can operate more efficiently and minimize the overall parasitic power consumption of CCUS processes.

Baker Hughes offers a range of products, including reciprocating, centrifugal and integrally geared CO₂ compressors, as well as centrifugal CO₂ pumps. These technologies have undergone years of proven in-field performance. Baker Hughes has also continued to develop and optimize these technologies at our global research centres, performing extensive testing in both laboratory and in-field environments before launching these products for our customers' use.

BENEFITS

- Reduced compression train parasitic power consumption
- Optimized high compression ratio across a wide range of flow rates
- Optimum rotor balance for low vibration level
- Easily accessible components for maintenance
- Automatic capacity control and safety system to reliably match any operating condition
- Reduced lead time through standardized and containerized production, design thinking for simplified logistics, and decreased demand for civil works

DESCRIPTION

The operating envelope for CO₂ delivery to sequestration sites is very broad in terms of volumetric flow and delivery pressure. It ranges from several thousand m³/h at relatively low pressures, up to a few hundred m³/h at extremely high pressures (700-800 bar). Baker Hughes offers a range of customizable CO₂ compression systems, depending on site conditions such as delivery pressure, temperature, cooling sources and gas composition. General configuration options for CO₂ compression are shown in the table below.

| PRESSURE | CONFIGURATION OPTIONS |
|-----------|---|
| < 200 bar | In-line compressor Integrally geared compressor + pump |
| > 200 bar | In-line compressor + HP pump Integrally geared compressor with MP pump + HP pump |

MP = medium pressure; HP = high pressure

Baker Hughes has optimized the configuration of the overall CO₂ compressor-pump train for CCUS applications. This includes the selection of the intermediate pressure between the last compression stage and the pump suction with the goal of decreasing the total power consumption and cost.

Integrally geared compressors

The main advantage of integrally geared centrifugal compressors are that coolers can be installed after each stand-alone stage. Baker Hughes' design features a bull gear and from one to four high-speed pinions, with one or two impellers mounted on each pinion shaft. Stand-alone stages optimize impeller speed and allow impellers to operate at higher peripheral speed and level of compression. Each stage can be fitted with inlet guide vanes to eliminate the need for recirculation for partial loads. The net result is a high efficiency operation that requires less work than an in-line compressor.

In-line centrifugal compressors

Baker Hughes has supplied more than 200 in-line compressor units with discharge pressure within the range of 200 bar. The typical train arrangement includes a steam turbine or electric motor that drives a low-speed, horizontally split compressor, and a high-speed barrel compressor through an increasing gearbox, typically followed by a pump for CO₂ injection. For applications where the CO₂ stream contains H₂S and water, Baker Hughes uses primarily stainless steel for improved corrosion resistance.

Pumps

Baker Hughes' development of its high-pressure CO₂ injection pumps rely on the experience of over 1,000 multi-stage centrifugal pumps for liquefied gas applications. Our multistage barrel pump is a good fit for CO₂ applications, providing better overall efficiency compared with the in-line rotor configurations, thanks to its opposing back-to-back impeller configuration.



SUREVIEW™ WITH COREBRIGHT™ OPTICAL FIBRE BAKER HUGHES

SUMMARY

Reliable downhole measurement of well and reservoir parameters is imperative to the success of geological sequestration projects. Baker Hughes is uniquely positioned to holistically address the monitoring challenges. Baker Hughes leverages a broad portfolio of technology and experience across permanent downhole gauges, microseismic monitoring, wireline monitoring, and fibre optic solutions. Specifically, fibre optic monitoring is an effective solution to gather a range of real-time data downhole. These systems can provide distributed

temperature, acoustic & strain measurements, transmit point gauge data, and capture seismic measurements for use in vertical seismic profiling. The majority of traditional downhole fibre optic installations are intended for 10-20 years of hydrocarbon production life. However, the geological sequestration projects can require much longer service life. SureVIEW™ with CoreBright™ technology is a proprietary fibre optic cable design with industry-leading 40+ years of reliability and unique resistance to common hydrogen darkening failure.

BENEFITS

- Collect multiple measurements with a single cable including distributed fibre optic sensing, pressure/temperature gauges for well integrity, compaction monitoring, and seismic data.
- Utilizes CoreBright™ hydrogen resistant fibres to limit the effects of hydrogen darkening
- Cable is clad with robust Inc 825 corrosion-resistant nickel alloy for maximum protection against chemicals, abrasion, crimping and crush.
- Continuous cable with no orbital welds
- Fibre In Metal Tube (FIMT) utilizes continuous (splice-free) fibres throughout
- Equipped with excess fibre to ensure that no strain is transferred to the optical fibre core during deployment or operation. Excess fibre compensates for thermal expansion, as well as tubing stretch.

DESCRIPTION

SureVIEW™ downhole cable by Baker Hughes uses CoreBright™ optical fibre, which leads the industry in hydrogen darkening resistance, a leading cause of failure for fibre optic systems over time. CoreBright™ fibre is constructed from pure silica that minimizes hydrogen darkening. The cable also includes a layer of hydrogen-absorbing gel. This combination provides the industry's best protection against hydrogen darkening.

Fabricating a downhole optical cable with the performance and reliability demanded by our industry requires a sophisticated understanding of fibre design, fibre coatings, cable manufacturing processes, and cable construction.

Fibres are typically coated, often with carbon, to prevent this hydrogen darkening. However, over time, this coating can break down or suffer from uneven application during manufacturing. A well applied coating will likely break down in about 20 years, particularly at higher temperatures (above 150 °C). CoreBright™ fibre offers its extended lifetime through a simple principle: instead of attempting to avoid hydrogen damage by trying to block hydrogen, CoreBright™ optical fibre avoids the hydrogen damage by preventing the reaction between the SiO₂ structure of the optical fibre and the hydrogen. In addition, Baker Hughes' fibre optic cables are fitted with hydrogen scavenging gels to further reduce darkening risk.

In this way, Baker Hughes' solution is unique: the fibre will not darken, and reliable readings over the full life of the installation are assured. Independent testing has concluded that CoreBright™ optical fibre is the only fibre in the industry that is suitable for harsh downhole environments over a long duration. It is the only known fibre that was designed for, and has demonstrated, long-term immunity to first and second-order hydrogen darkening effects.¹

SureVIEW™ fibre optic cables, powered by CoreBright™ fibre, have been installed in over 300 wells worldwide. As of today, there are no instances of hydrogen darkening ever experienced. In addition, during high-temperature monitoring work performed by Baker Hughes for electrical submersible pumps where it is common practice to test the fibre as the pumps are pulled, the CoreBright™ fibre has



maintained its mechanical and optical reliability in every instance. Proof-testing of the fibre showed levels that are typical of 'as-built' condition and demonstrated negligible changes in optical loss profiles.

High reliability and longevity enable the use of fibre optic measurement in more applications particularly behind the casing where workover is likely impossible. Baker Hughes' SureVIEW™ downhole cable is expected to improve data quality and facilitate better decision-making in geological sequestration today.

¹ "Hydrogen Darkening Under Hydrogen Conditions", SEAFOM Industry Meeting (Dec. 2012)

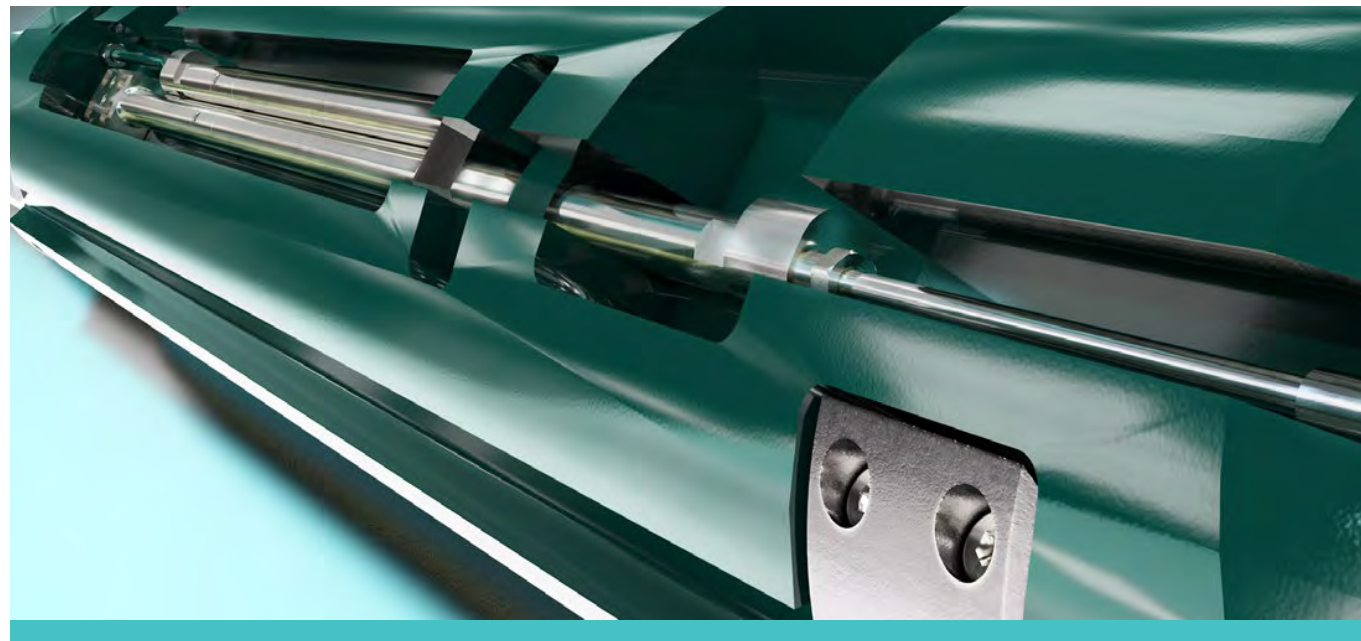

SURESENS™ QPT ELITE PDHG BAKER HUGHES

SUMMARY

Well-known pressure and temperature are key to proper functioning throughout a CO₂ storage system. For most applications, the best way to monitor these parameters is with permanent downhole gauges (PDHGs). These gauges can be used as a standalone means of measurement or as calibration for a fibre optic-based or other extensive

measurement system. Baker Hughes leverages the quality and performance of the SureSENS™ line to execute integrated monitoring solutions that combine point gauges, fibre optics, along with periodic means of measurement such as wireline logging data.

BENEFITS

- Provides superior reliability in long-life and/or demanding (high-pressure and high-temperature) applications
- Derives finest pressure/temperature measurement resolution attainable
- Deploys multiple gauge combinations on a single standardized carrier
- Eliminates the need for additional splices, increases reliability, and reduces installation time through unique construction configurations with fewer connections
- Deploys multiple gauges, flowmeters, and valve positions to provide redundant readings
- Serves as platform for future developments

DESCRIPTION

The SureSENS™ QPT ELITE gauge for permanent downhole installations measures static and dynamic pressures and temperatures while introducing a step change in reliability and accuracy. The gauge is qualified for operation at pressures less than 35,000 psi (2,414 bar) and temperatures up to 225 °C (437 °F). The static and dynamic pressure information obtained can be used to determine the effects of injection and plume growth on monitoring wells, monitor injection characteristics, and provide input or validation to reservoir models. The SureSENS™ QPT ELITE gauge includes the new ELITE electronics package, built upon Baker Hughes' industry-leading STAR hybrid electronic package design. The ELITE electronics package incorporates an application-specific integrated circuit (ASIC), providing a new level of reliability to the industry. Baker Hughes provides three configuration options—single, dual, and triple gauge. The single-gauge configuration is an economical option that will also permit the smallest possible running diameter for a streamlined, slim-hole gauge carrier. A dual-gauge configuration provides isolated operational redundancy of electronics and transducer at any given installation point. Each gauge in a dual package operates individually, providing independent measurements for data redundancy

and integrity verification. The triple gauge option can offer redundancy or be ported to record three independent pressure measurements. The shorter carrier for a side-by-side triple-gauge assembly also retains a slim hole running outside diameter.

For applications requiring long active life and high data accuracy, even in demanding high-pressure/high-temperature type environments, the SureSENS™ QPT ELITE gauge system provides a flexible and reliable solution.

Being highly robust, the SureSENS™ QPT ELITE gauge maintains mechanical integrity by deep-penetration and high vacuum, electron-beam fusion welds, without the need for filler material. Only two fittings, the pressure port and the tubing encapsulated conductor (TEC), are required to interface the gauge with the carrier. The gauge pressure interface connection to the carrier can be externally tested in the direction in which it will experience pressure, eliminating the need for an internal pressure test tool. The TEC's primary seal is a dual metal-to-metal pressure-testable interface. The mechanical package is completely integrated into the gauge assembly, which eliminates the requirement for external Y-block components.



Gauge Carrier configured with QPT ELITE permanent downhole gauge

¹ "Reduced Temperatures Under Hydrogen Conditions", SEAFOM Industry Meeting (Dec. 2012)

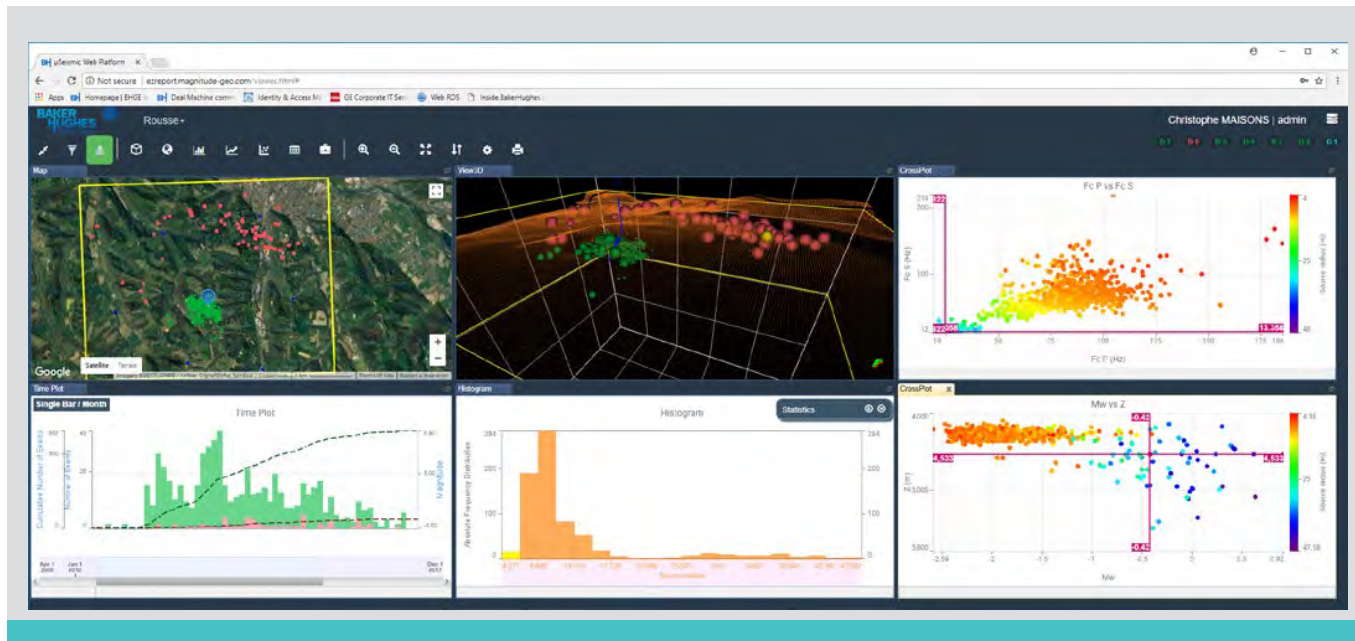

MICROSEISMIC MONITORING SERVICES BAKER HUGHES

SUMMARY

Monitoring seismicity is essential to guarantee the integrity of geological sequestration reservoirs and caverns. In terms of physical integrity, seismicity in the cap rock is an indicator of the risk of catastrophic failure. At the reservoir scale, seismicity at faults can identify the reactivation by fluid injection or that they provide a pathway to the surface for the stored fluids. With more public attention towards induced seismicity and environmental impact

of human activity, reputational integrity is becoming as important as physical integrity. It is therefore becoming essential to detect growing activity trends before critical situation happens to support operators' injection program. Baker Hughes provides the whole range of customized microseismic services and instrumentation to provide lifetime monitoring of CCS assets.

BENEFITS

- Maximize storage capacity within safety limits
- Compliance with regulations
- Monitor structure integrity (cap-rock & faults)
- Distinguish induced versus natural seismicity
- Avoid water breakthrough

DESCRIPTION

The range of the monitoring solution can be described in 3 distinct stages that can be performed as a whole or as independent services.

Network design

In this phase, consideration is given to the project's constraints (regulatory, geological, operational and logistical) and advanced modelling is used to determine the most cost-effective network that will meet the project's objectives. This network can consist of a specific technology (surface or downhole solutions with analogic geophone or fibre optics) to be deployed, but can also have a combination of them to benefit from their different capabilities.

Installation and maintenance

Baker Hughes ensures supply of all the required instrumentation: surface sensors, shallow buried sensors (100 m), borehole sensors, surface electronics, fibre optics, digitizers, and fully equipped seismic cabinets. Where not internally developed, Baker Hughes works with trusted suppliers with long-term relationships to develop reliable hardware (Mean Time Between Failures of more than five years) with advanced capabilities.

Baker Hughes installs and maintains all the instrumentation, including borehole sensors. The requirement for preventive maintenance is extremely low (one visit a year at most). This allows us to operate sites all over the world. Most of the sites are totally autonomous, relying on solar panels for power and 4G networks for communications.



Monitoring - Processing

A dedicated team of experts processes the data and reports on the seismicity through a dedicated web portal. The portal allows the operator to visualize the seismicity in two-dimensions (2D) or 3D along with the well trajectories and formation interfaces and offers statistical analysis capabilities. It also plays the monitoring network's state of health and expected sensitivity in real time. Pressure and/or flow rate curves can be displayed along with seismic rates to easily relate any seismic activity to its probable cause.

Automation of the process can be utilised to enhance the processing solution by adding 24/7 services such as traffic light systems that will alert the operator when critical seismicity is reached, and the prediction of the level of seismic risk for the upcoming hours using machine learning.

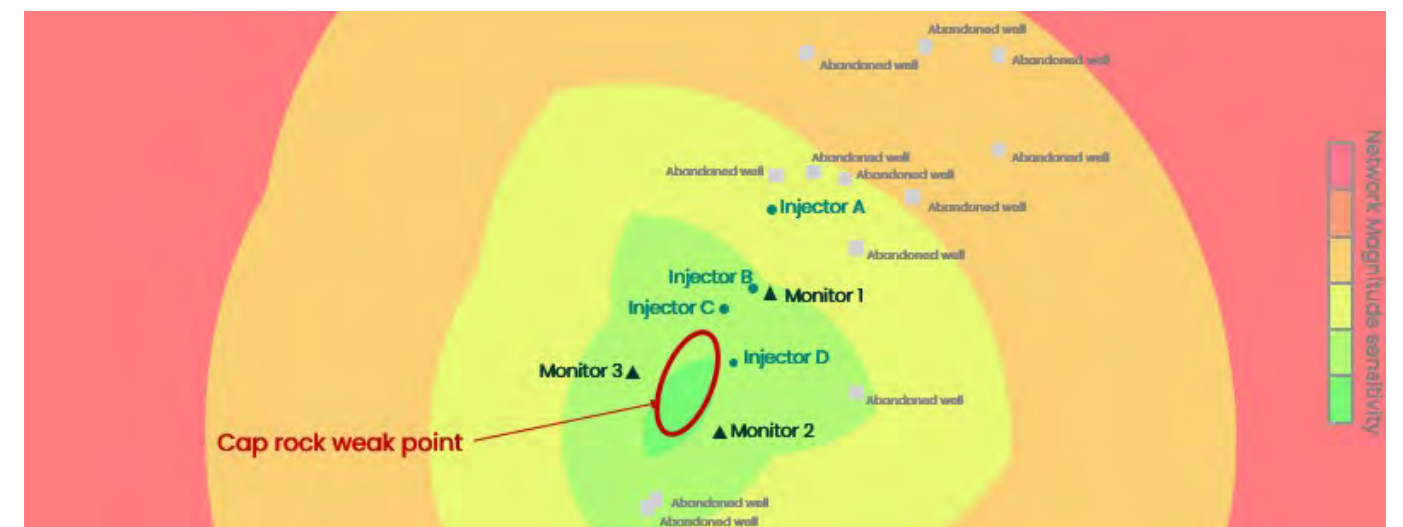

¹ "Temperature Under Hydrogen Conditions", SEAFOM Industry Meeting (Dec. 2012)

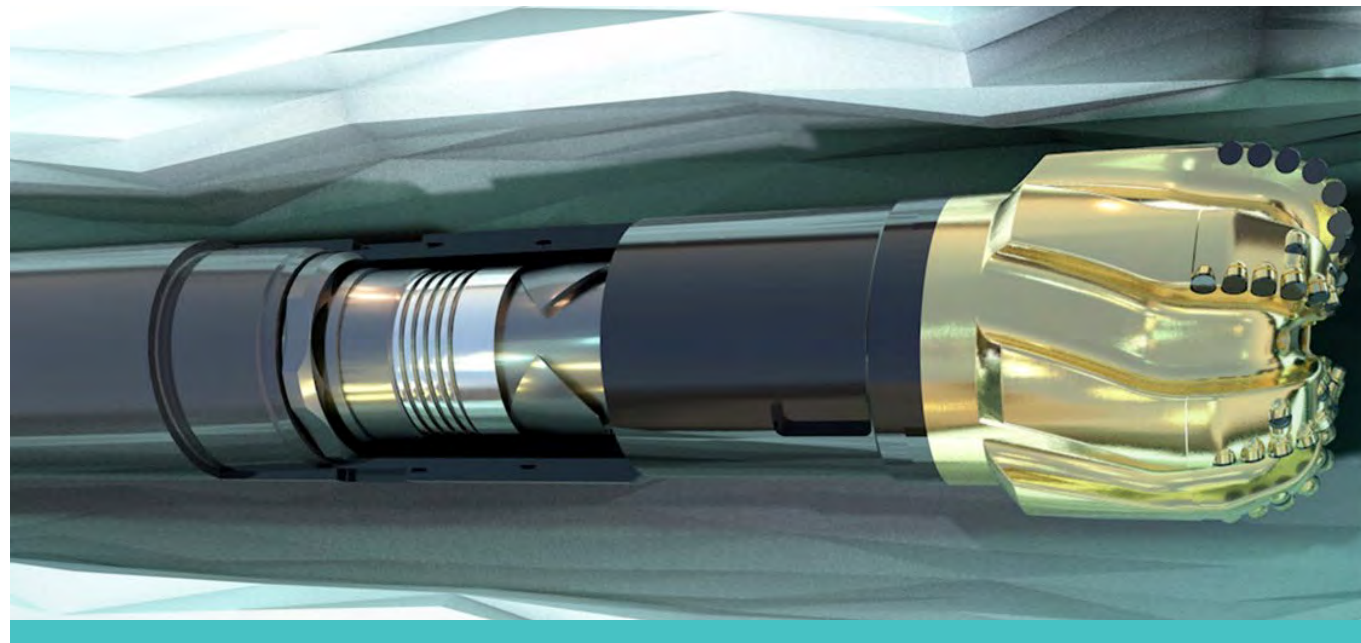

CORTIVA™ CORING SYSTEM BAKER HUGHES

SUMMARY

Seal integrity is key to the success of any geological sequestration project. Along with the logging and measurement technology, taking physical cores is one of the best ways to characterize these structures. Core samples retrieved with traditional coring systems can often break and become jammed or lost in a hole. Jams and poor core quality can lead to re-runs that incur significant

additional cost. The CORTIVA™ coring system improves efficiency and de-risks core recovery through the use of a fully-closed and jam-mitigating core barrel. By combining these key features, CORTIVA™ shortens the time and costs required to cut and retrieve a core sample by ensuring the whole core section is retrieved safely in a single trip.

BENEFITS

- Core longer even in fractured or other jam-prone formations by neutralizing up to two jamming events
- Full-closure catcher completely seals inner tube to prevent loss even when the core is unconsolidated
- The HT30™ Max core barrel system delivers larger, longer samples than other systems
- Unobstructed 'slick' entry eliminates risk of jam at core's centre

DESCRIPTION

Core jamming during coring operations and/or loss of friable core material during trip-outs leads to additional coring runs, resulting in increased rig time and cost. Jams that occur inside the inner tube of a core barrel can often be mitigated by certain jam-mitigation techniques, allowing coring to continue. However, jams that occur in the core catcher, provoked by the mechanical interaction of the core with the catcher mechanism, would not be mitigated by such anti-jamming technologies. These typically occur in formations that are a mixture of fractured (jamming-prone) and friable rock. This type of complex, coring application demands technologies beyond what is currently available in the market. Competitors have either standalone jam mitigation systems for jam-prone formations, or full-closure catcher systems for unconsolidated/friable rock.

Baker Hughes combines the benefits of various technologies to improve the efficiency of coring operations in complex formations. With its CORTIVA™ full-closure system with jam mitigation technology, Baker Hughes combines the JamBuster™ jam mitigation coring system and the

HydroLift™ full-closure catcher system—industry standards for jam mitigation and recovery of friable rock to improve the efficiency and recovery of high-quality core in complex fractured and friable formations.

The Baker Hughes patented JamBuster™ system neutralizes jams inside the inner tube through concentric inner core barrel sleeves that automatically telescope if a core becomes jammed in the core barrel, allowing coring to continue without interruption. The HydroLift™ system efficiently recovers high-quality, intact core samples collected in soft, or unconsolidated formations. The system's slick, unobstructed entry eliminates the risk of jamming at the core catcher for the incoming core, while the full closure mechanism secures the core, thus preventing loss of friable/ loose formation during trip-out.

The CORTIVA™ full-closure system with jam mitigation technology is also integrated with HT30™ Max core barrel system to deliver an unmatched core size. It also reduces core acquisition costs by acquiring longer, high-quality core samples per run, even in harsh environments.





APTUM™ DOWNHOLE SEALS BAKER HUGHES

SUMMARY

In geological sequestration, completion integrity for any well penetrating the target storage interval is key to maintaining storage integrity over the life of the project. Chemical corrosion inhibitors and reservoir’s environmental factors can be damaging to elastomer seals over time. The most common sealing elastomers in the industry today often force a choice between effectiveness at low temperatures or chemical compatibility with corrosion

inhibitors. Aptum™ seal systems, along with industry-leading packers such as the Premier™ NXT removable production packer, perform at lower, more appropriate temperatures for CCUS and yet maintain excellent chemical compatibility and mechanical properties. With Aptum™ seals in the completion, operators can better protect their metal tubulars and equipment without fear of elastomer degradation.

BENEFITS

- Delivers high performance across a wide temperature range
- Compatible in a range of environments including corrosion-inhibited fluids and reservoir fluids
- Resistant to sour conditions
- Single compound simplifies material recommendations and testing for well planning across all seals including packing elements, O-rings, and bonded seals
- Extends life of seal, further improving reliability
- Meets ISO 23936-2 and API 11D1 standard

DESCRIPTION

In typical well completions, the injection or monitoring tubing string is isolated from the well casing by a production packer. This packer creates a mechanical anchor and a seal between the tubing and casing. The four main elastomers currently used in these packer element systems to seal between the tubing and the casing are Nitrile (NBR), hydrogenated Nitrile (HNBR), Aflas (FEPM), and Viton (FKM). These elastomers provide an excellent range of capabilities for most applications. However, in each case, there are trade-offs, which can introduce risks and costs to an operation.

For instance, NBR has balanced mechanical properties and performs well even at lower temperatures. However, its chemical resistance, particularly to corrosion inhibitors, is quite low. Aflas, on the other hand, is excellent for use in many inhibited brines, but has significant limitations in lower temperatures. Baker Hughes set out to develop a balanced element system that could be used confidently in a broader range of applications – carbon storage being a prime example.

| MATERIALS | TEMPERATURE 40 °F (4 °C) | TEMPERATURE 350 °F (177 °C) | INHIBITED BRINE >200 °F (93.3 °C) | BROMIDE RESISTANCE | OIL-BASED MUD RESISTANCE | H ₂ S RESISTANCE >10% | BALANCED MECHANICAL PROPERTIES | PRODUCED RESERVOIR FLUIDS |
|-----------------------------|-----------------------------|--------------------------------|---|-----------------------|--------------------------------|--|--------------------------------------|---------------------------------|
| Aptum Seal | ○ | ○ | ○ | ○ | ○ | ○ | ○ | ○ |
| Nitrile (NBR) | ○ | X | X | X | ○ | X | ○ | X |
| Hydrogenated Nitrile (HNBR) | ○ | ○ | X | X | ○ | X | X | ○ |
| Viton (FKM) | ○ | ○ | X | X | ○ | ○ | ○ | X |
| Aflas (FEPM) | X | ○ | ○ | ○ | ○ | ○ | ○ | ○ |

Due to excessive swelling, limit exposure to oil-based mud (OBM) during run-in

Due to excessive swelling, O-rings and packing elements require back-up mechanisms to reduce extrusion

Aptum™ seals are compatible with a range of industry standard corrosion inhibitors while still maintaining sealing capabilities in low downhole temperatures.

Carbon storage applications can create corrosive environments when CO₂ becomes mixed with water and other fluids in the wellbore. Completion equipment can often be exposed to hydrocarbons, formation water, CO₂ and a host of other corrosive fluids. A common and effective way of combating this corrosion is to treat the completion fluids with corrosion inhibitors. These corrosion inhibitors protect the metallic components of the completion including the casing, tubing, and packer body. However, they can also degrade the elastomer. As mentioned earlier, elastomers with excellent compatibility with inhibited fluids often have temperature limitations.

Many target formations for sequestration are shallow and have lower temperatures, making them difficult applications for elastomers such as Aflas. Add the potential for significant cooling during various phases of CO₂-injection operations, and a new solution is needed. Aptum™ provides excellent performance at 4 °C (40 °F) yet maintains long-term compatibility with bromide- and chloride-inhibited brines.

When used as a part of the Premier™ removable production packer, Aptum™ seals enable a secure seal between the tubing and the casing, create a reliable mechanical anchor for the tubing string throughout extreme temperature and pressure changes, and is easily removed from the well for workover or plug and abandonment activities.



HEAVY METAL™ SWARF-FREE SECTION MILLING BAKER HUGHES

SUMMARY

Many of the world's most promising geological targets for large scale CO₂ storage exist in and above late-life and depleted hydrocarbon plays. Late-life fields often have many existing wells that penetrate the target storage geology and can pose seal integrity risks. Baker Hughes offers advanced plug and abandonment solutions to ensure that the integrity of aging infrastructure is not compromised for the life of the sequestration project. During plug and abandonment operations, it is sometimes required to remove a section of the casing and adjacent cement sheath to expose the formation. This process is called section milling. Section milling operations provide an effective downhole seal during plug and abandonment

by setting a cement plug directly across the geologic seal - removing metal tubulars and potentially failed cement. However, section milling operations can be challenging, which makes its large scale use less appealing. Additionally, conventional section milling requires specialized equipment to handle the cuttings or 'swarf' that are brought to surface during milling operations. HEAVY METAL™ swarf-free section milling system increases the efficiency while decreasing the cost and carbon footprint of section milling operations. By improving the performance and economics of section milling operations, wells can be plugged more effectively and with less long-term risk of seal integrity issues.

BENEFITS

- Provides a robust rock-to-rock barrier
- Reduces cost and time associated with section milling
- Decreased health, safety & environment (HSE) risk for personnel on site
- Reduces requirements for rig capability, swarf handling, and other specialized equipment
- Eliminates the need for swarf cleaning, transport, and disposal

DESCRIPTION

Section milling is a conventional method for casing removal during plug and abandonment (P&A) operations where annular well integrity is compromised or questioned. The removal of casing by milling a window provides full access to the virgin formation, enabling placement of a rock-to-rock barrier. Swarf is an unavoidable by-product of section milling, generating thousands of pounds of these sharp metal cuttings that have to be removed from the well. Retrieving and handling the swarf is a time-consuming and costly process that poses additional health, safety, and environmental (HSE) risks, and oftentimes operators will opt for less reliable options, such as perf-and-wash, just to avoid swarf.

Baker Hughes offers the HEAVY METAL™ swarf-free section milling service to provide a reliable solution without the negative side effects of swarf. It eliminates swarf to surface through a unique upwards milling process, depositing swarf deep in the rathole, while still enabling a secure rock-to-rock barrier. This unique service reduces time and costs in half, eliminating the need for swarf removal and the risks that swarf presents to people, equipment, and the environment. The bottomhole assembly (BHA) consists of multiple tools providing different functions to enable upwards section milling using normal right hand drill pipe connections without any rotation at surface. A torque isolator allows uninterrupted axial movement and

continuously isolates reactive torque of the left-hand mud motor, while milling upwards. The mud motor requires circulation from surface and provides downhole left-hand-rotation and torque to the section mill and auger.

The system's section mill features upward-facing knives that utilize METAL MUNCHER™ advanced milling technology (AMT) carbide cutting structures and allow upward milling and reaming in one run—even in long laterals. The section mill cuts through the casing at the bottom of the window, mills upwards to the desired distance, and then reliably retracts its knives at the top of the window.

The auger continuously transports any swarf created from the window to the bottom of the rathole, leaving it all in the well, while providing a window free of swarf. Because the swarf does not have to be circulated to surface, there is no need to change over to a high viscosity milling fluid, saving additional cost and logistics.

A Baker Hughes dedicated project management team can oversee the entire P&A project—from planning phase through final abandonment— all with a strong focus on safety and efficiency. With a single point of contact, customers achieve a simplified, streamlined process that helps reduce time and minimize risk.

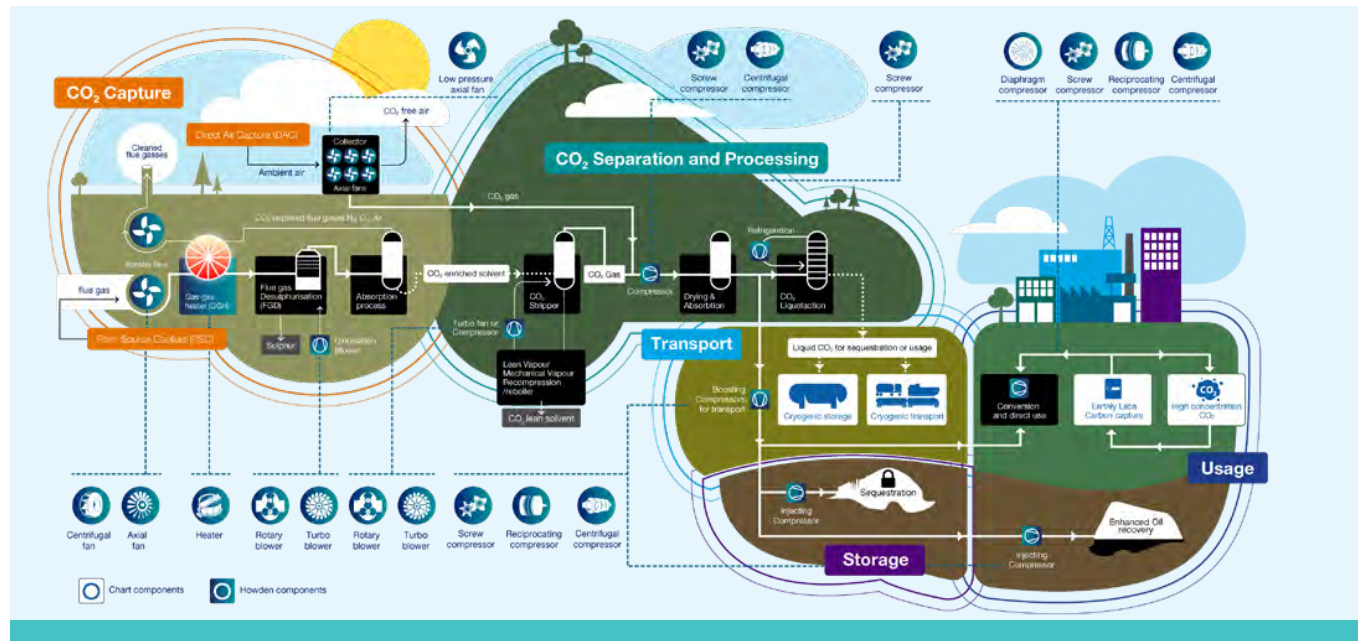

CARBON CAPTURE, UTILIZATION AND STORAGE CHART INDUSTRIES, INC.

SUMMARY

Carbon Capture, Utilization and Storage (CCUS) is a necessity, not an option, and could contribute up to 20% of global emissions reductions required (International Energy Agency). One hundred times the current levels of carbon capture will be needed by 2050 to keep global warming below 1.5°C.

Chart Industries, Inc. is a global leader in the design, engineering and manufacturing of process technology and equipment. With more than 80 years' experience in industrial gases and diverse knowledge in cryogenic

processes, Chart delivers the effective solutions to tackle carbon emission challenges.

In March 2023, Chart completed the acquisition of Howden, a leading global provider of mission critical air and gas handling products and services for over 165 years. The combination of Chart and Howden expands the offering of products and services to provide a unique range of efficient, sustainable and innovative technologies to support customers in all stages of the CCUS value chain.

BENEFITS

- Unique combination of products and services across the full CCUS value chain including the expanding applications for Cryogenic Carbon Capture™ (CCC™).
- Over 15 years' experience and participation in 8 large-scale CCUS projects and 2 current 30 Tonnes Per Day (tpd) CCC™ projects.
- Full product range includes fans, heaters, compressors, CO₂ capture and processing hardware, storage tanks, transportation tanks and remote monitoring systems for both gas and liquid.
- Chart's CCC™ Systems are providing results without the use of chemicals or contaminants, providing significant cost and energy savings.
- Significant knowledge of the processes and challenges of energy intensive hard to abate industries such as Power, Oil & Gas, Petrochemical, Steel and Cement.

DESCRIPTION

EFFICIENT AND INNOVATIVE SOLUTIONS ACROSS THE FULL CCUS VALUE CHAIN

CO₂ Capture and Separation

CO₂ is captured either at source (Post Combustion/Post Process Capture) or from the air (Direct Air Capture).

Post Combustion Capture

Post Combustion Capture is the process of capturing CO₂ emissions at source before they are released into the atmosphere, which is particularly relevant for large-scale industrial facilities which rely on fossil fuels. This includes facilities such as power plants, cement production facilities and chemical plants where limited alternative clean fuel sources are available. Capture at source allows these industries to continue to operate without releasing significant levels of CO₂. Howden supports post-combustion capture with booster fans, gas-gas heaters and oxidation blowers.

Many other industrial processes, like fermentation or chemical reactions, also generate large quantities of CO₂ that is also best captured at relatively high concentration at source.

Howden is a world leader in Mechanical Vapour Recompression (MVR) technologies, which is a key element for reduced energy in the separation of CO₂ from the solvent that captured the CO₂. Roots Blowers and Howden Turbo Compressors or blowers form the basis of the MVR systems.

Cryogenic Carbon Capture™ (CCC)

In addition to traditional carbon capture methods, Chart offers Cryogenic Carbon Capture™ systems, which as the names implies, uses the thermodynamics of pressure and low temperatures to separate the CO₂ from plant or process exhaust. The CO₂ is captured, separated, purified and pressurized in a single process, and delivered as a high-purity liquid ready for transport, storage or re-use. More information about the full CCC process can be found later in this article.

CO₂ purification and dehydration

After it is captured, the CO₂ is then purified, treated and prepared for permanent storage (sequestration) or direct usage. Depending on the required capacity, flexibility, reliability and efficiency, the most suitable Howden compression technologies can be selected from screw, centrifugal, piston or diaphragm compressors to compress and condense the CO₂ ready for transport, storage or use.

In some cases there is an opportunity for substantial operational and energy cost savings by using multi machine systems where Howden can select individual compressors based on optimization of full and part-load performance, CAPEX and OPEX.

Transport, Storage and Use

After the CO₂ has been separated and processed, it is then transported from where it was captured either to a storage site for permanent storage or for direct use.

Transport

There are multiple ways the CO₂ can be transported including transporting it in a pressurized tank by car, railway or ships, or through a pipeline. Depending on the specific requirements, Howden can supply a screw, reciprocating or centrifugal compressor to transport the gas, and boost it for injection & Enhanced Oil Recovery (EOR) purposes.

Storage of CO₂ in Gas or Liquid

CO₂ can be stored as a liquid or a gas depending on the downstream use. For decades Chart has provided leading cryogenic CO₂ storage solutions for the industrial gas market from transportable liquid cylinders such as the Dura-Cyl® and Carbo-Max® equipment for pilot and small-scale systems to industrial bulk tanks, CO₂ ISO units or CO₂ tank trucks. Chart's solutions have been in service for decades and are available globally to support customers in CO₂.



Howden Turbo fans to produce bioethanol from CO₂ at Arcelor Mittal

Direct Air Capture (DAC)

Direct Air Capture is the process of capturing CO₂ directly from the ambient air using fans to draw in the air and then trap the CO₂. Both Chart and Howden provide the low-pressure axial fans that would be mounted on top of a DAC tower to draw air through a recirculating fluid or through a solid sorbent which traps the CO₂ from the ambient air. DAC is an emerging technology and as the technology develops further, will benefit from higher pressure centrifugal fans, a core capability of Howden.

Sequestration of CO₂ Gases

CO₂ sequestration is the process of permanently storing the captured CO₂. Often permanent sequestration is referenced to mean storage deep underground in geological formations such as saline formations, oil and natural gas reservoirs, coal seams, basalt formations and organic-rich shales. Howden compressors can boost pressure to over 200 bar for injection of the CO₂ into these porous rock formations to permanently trap it away from the atmosphere. As this is a growing field of study, there are methods of permanent sequestration of CO₂ (or converted derivatives) to extend to agriculture soil amendments and water and matter entrainment, binding the CO₂ molecule in a way that prevents future release.

Direct Use or Re-use of CO₂ (Utilization)

The captured CO₂ gas can be used in a wide range of industries such as production of materials, urea/fertiliser production, food and beverage, healthcare, water treatment, refrigeration, indoor agriculture and biofuel production. Chart provides the CO₂ tank and mobile storage solutions to enable CO₂ reuse or distribution. Howden has been optimizing its compressors to handle CO₂ for many decades. In the many diverse industries that can utilise captured CO₂, such as the Food and Beverage industry, Howden already supplies tailor made screw, diaphragm, piston and centrifugal compressors to plants around the world.

Chart - Carbon Capture System Solutions

Cryogenic Carbon Capture™ (CCC)

Cryogenic Carbon Capture™ is a post-combustion technology that reduces carbon emissions from fossil fueled power stations, cement, steel, and other industrial facilities using cryogenics to separate the CO₂ in a highly efficient process delivering high-purity, liquid CO₂ (LCO₂) ready for transportation, storage and use.

Chart acquired Sustainable Energy Solutions (SES) in 2020 to scale and commercialize the CCC process with the potential to reduce carbon emissions from all types of post-combustion emissions sources by 95% to 99% and remove other pollutants, such as sulphur oxides, nitrogen oxides, and mercury, at half the cost and energy of alternative carbon capture technologies. Current projects are proving the large-scale reliability, efficiency, and scalability of the CCC process to achieve cost-effective carbon capture for power and industrial markets.

The CCC technology uses phase change to separate CO₂ and other pollutants from exhaust gases. Cooling the exhaust gas results in the CO₂ gas transforming into a solid without passing through the liquid phase (desublimation); the CO₂ is then separated from the remaining gas, pressurized, and melted resulting in liquid CO₂ ready for transportation and use.

The CCC process is minimally invasive and highly efficient, effectively utilizing heat integration to achieve up to a 50% reduction in parasitic energy demand depending on project-specific conditions compared to an amine absorption process.

While traditional carbon capture methods seek to lower the Carbon Intensity (CI) scores of many applications, the unique liquefaction process of CCC cleans the carbon meaning it can be resold or reused as Liquid CO₂. An example of this is the oil and gas industry, where the CO₂ can be used for enhanced oil recovery. SES has also demonstrated use of the CO₂ for a variety of cases including curing concrete and converting the CO₂ to useful products.

Chart's CCC process results in high purity LCO₂, which can be used in a range of applications including chemical manufacturing, synthetic fuel production, concrete curing, food and beverage and enhancing plant growth at commercial nurseries. Chart engineers and manufactures the low-pressure cryogenic storage tanks, transportation equipment, loading and unloading skids, and end user re-use equipment for multiple applications of CO₂. From storage tanks of 1000m³ size to ISO units, to MicroBulk solutions, Chart can deliver the effective solutions for re-use on site or re-use in a range of applications.

Small-scale Carbon Capture with Earthly Labs Technology

Earthly Labs technology is uniquely designed to capture carbon dioxide waste from lower volume, higher concentration sources such as breweries, wineries and biogas and purifying CO₂ for beverage quality reuse. Earthly Labs offers a full solution including CO₂ capture hardware, software, installation, and remote monitoring services. The CO₂ is captured, purified, monitored and reused. The technology is proven, compact and cost effective, capturing millions of carbon dioxide molecules annually helping customers save thousands in CO₂ and reducing greenhouse gas emissions.

An example of where the Earthly Labs technology is making a significant impact is craft breweries. The CO₂ is captured from fermentation tanks and pushed through a foam trap into the compact CO₂ capture unit, where all purification, compression and liquefaction is carried out. The resulting Liquid CO₂ from the process is then transferred into a Chart storage tank and the brewer uses the liquid CO₂ to carbonate their beer and purge tanks. In addition to reducing their carbon emissions every week, the breweries are reducing supply chain risk in an increasing volatile CO₂ market, reducing their use of industrial CO₂, reducing costs and advancing their sustainability goals.

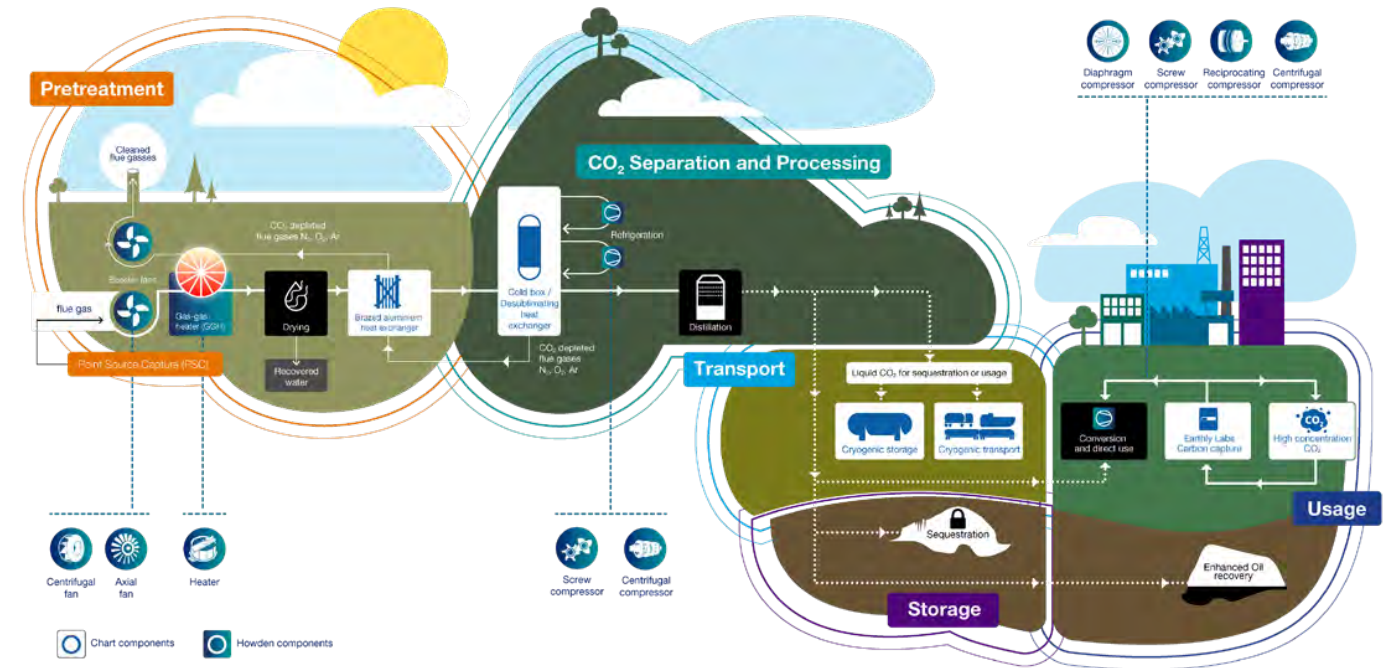

Chart Industries product offerings for Cryogenic Carbon Capture™ (CCC™)



Small-scale Carbon Capture with Earthly Labs Technology



CONTACT

Email: newenergies@chevron.com

Web: www.chevron.com/operations/new-energies



CARBON CAPTURE, UTILIZATION, AND STORAGE CHEVRON NEW ENERGIES

SUMMARY

In a growing world faced with complex energy challenges, innovative solutions are required to deliver a lower carbon future. At Chevron New Energies, we understand the importance of addressing climate change and accelerating lower carbon solutions. Chevron's strength has always been solving big, complex energy challenges.

Our Company's energy transition approach is straightforward: we are lowering the carbon intensity of our operations and growing lower carbon businesses

by leveraging our capabilities, assets, and customer relationships. We are scaling and commercializing new businesses to meet customers' lower carbon ambitions through a portfolio of energy solutions that include carbon capture, utilization, and storage; hydrogen; carbon offsets; emerging technologies; and renewable fuels and products. We aim to help reduce emissions of the essential industries, such as refining, petrochemicals, steel, and cement that enable modern society for a better tomorrow.

BENEFITS

- Chevron New Energies is well-placed to be a CCUS leader building upon our capabilities, assets, and customer relationships.
- We bring decades of operational experience and a proven track record of carbon capture projects.
- We are one of few companies with the ability to execute across the CCUS value chain and scale this critical technology.
- Our direct experience in understanding and driving portfolio-wide emissions reductions enables us to collaborate with customers to help solve their lower carbon needs.
- We are a full-service provider with a balanced approach to develop decarbonization solutions with customers in our key geographies of North America and Asia Pacific.
- Chevron has committed \$10B total capital toward lower carbon energy by 2028 to progress our ambitions.

DESCRIPTION

SCALING CCUS

Carbon capture, utilization, and storage (CCUS) is a critical enabler for achieving global net zero goals. Chevron New Energies is advancing CCUS and next generation technologies by scaling viable lower carbon solutions across the value chain to help our company and industrial customers reach their lower carbon ambitions. We are targeting 25 million tonnes of CO₂ per year in equity storage by the end of this decade, with a focus on developing regional hubs that leverage our existing and new partnerships with customers, governments, and industry.

Chevron is actively evaluating multiple locations globally to implement CCUS solutions. We see a future in the development of CO₂ hubs where emissions from multiple sources are combined for permanent sequestration in underground storage reservoirs. As hub concepts and projects are developed, neighboring industrial plants and third-party emitters can be enrolled as potential partners and customers.

We are investing in and piloting emerging technologies across the CCUS value chain to reduce costs, develop new ways to capture, use, and sequester CO₂, with the goal of scaling these solutions.

We're also taking action to reduce the carbon intensity of our own operations. Using the marginal abatement cost curve (MACC) process, we have direct experience

in understanding and driving portfolio-wide emissions reductions. We can leverage this experience to collaborate with customers to help address their lower carbon needs.

Chevron has committed \$10B in total capital towards lower carbon energy by 2028 to help progress our energy transition ambitions.

PROJECT AND PARTNERSHIP HIGHLIGHTS

Chevron brings decades of operational experience through our large-scale deployment of CO₂ injection in the United States over the last 40 years. We have safely operated a CO₂ pipeline in Colorado for 35 years. This experience is coupled with our capabilities in drilling, geology, injection, pipeline operations, monitoring and managing pressure in wells, and our ability to successfully bring together diverse stakeholders across the value chain.

In Australia, the Chevron-operated Gorgon liquefied natural gas (LNG) facility incorporates one of the world's largest integrated carbon capture and storage (CCS) systems. Naturally occurring CO₂ found in the offshore gas reservoirs that supply the Gorgon LNG facility is injected into a large sandstone formation two kilometers beneath Barrow Island. More than 7.8MM tonnes of GHG emissions have been captured and stored since the system started up in mid-2019; we expect to mitigate more than 100MM tonnes of CO₂ over the life of the project.



Carbon Capture demonstration with Svante and National Energy Technology Laboratory (project #DE-FE0031944)



Chevron recently became the operator of Bayou Bend CCS, a carbon capture and storage project located along the Texas Gulf Coast. We announced an expansion of its CO₂ storage footprint through the acquisition of nearly 100,000 acres onshore in Chambers and Jefferson Counties, Texas. With a gross storage capacity of more than one billion metric tons, Bayou Bend CCS is positioned to be one of the largest carbon storage projects in the United States, and a leading transportation and storage solution for industrial emitters located in the Houston Ship Channel and Beaumont / Port Arthur region, one of the largest industrial corridors in the country.

Chevron aims to reduce the carbon intensity in San Joaquin Valley, CA. The proposed carbon capture and storage project at our Eastridge facility entails installing CO₂ post-combustion capture equipment, compressing the CO₂, and then injecting the CO₂ into the subsurface for permanent storage.

Chevron New Energies is a part of three joint ventures that have been granted an interest in three offshore greenhouse gas storage assessment permits in Australia. Additionally, Chevron announced a memorandum of understanding with Air Liquide, Keppel Infrastructure and PetroChina to advance the development of large-scale CCUS solutions in Singapore.

We are investing in CCUS technologies (e.g., Carbon Clean Solutions, Svante, Blue Planet, Ocean GeoLoop) to bring early insights through pilot programs – often utilizing Chevron’s existing assets – and to accelerate commercialization of promising technologies.

We are advancing a project awarded from the U.S. Department of Energy (#DE-FE0031944) to pilot technology that captures CO₂ from post-combustion gas at our Kern River Carbon Capture site in San Joaquin Valley, California. In collaboration with Svante and the National Energy Technology Laboratory, we launched a 6-month pilot of Svante technology at scale in November 2022 with the goal to reduce CO₂ capture costs and help commercialize this technology.

ACCELERATING LOWER CARBON SOLUTIONS

Our capabilities, assets, and customer relationships will serve as a platform for rapid growth in the years to come. We bring a unique set of capabilities to each of these areas. Our existing assets span the value chain and are in areas where we can facilitate demand based on cost-competitive supply combined with appropriate policy support. We have strong relationships with key customers and partners, which will be critical in developing economic projects that can scale quickly across a complex value chain.

Innovation, partnerships, and policy will be key drivers of change. We begin with a portfolio of existing assets and decades of experience as a strong foundation for future growth. We’ve successfully managed complex joint ventures all over the world. We have deep technical expertise and a long history of advancing and adopting external innovation. We have strong commercial capabilities and experience managing rapidly changing businesses. Managing diverse stakeholder and government interests is something we do every day. Chevron’s credibility and reputation make us the partner of choice, bringing access to new opportunities. Chevron New Energies is taking action to help build the lower carbon energy system of tomorrow.



Employees at Chevron’s Gorgon Project in Australia



CONTACT

Email: roberto.ferrario@eni.com
 Web: www.eni.com



NAME OF TECHNOLOGY

ENI

SUMMARY

Eni is building a leadership position as a provider of decarbonization services, based on a portfolio of cross-business technology solutions and a balanced mix of low carbon products in order to effectively address scope 1+2+3 emissions. Eni's strategy aims to deliver a secure and sustainable energy system, while keeping a sharp focus on a just energy transition and value creation for stakeholders. Carbon Capture, Utilization, and Storage (CCUS) is one of the main pillars of this strategy. Specifically, we are addressing industry needs, in particular for the Hard-to-Abate sectors. As a global energy company with decades of experience and leader in technological development, Eni already has an extensive heritage in operations, subsurface characterization, modeling, and monitoring.

This know-how has been transferred to CCUS leveraging on existing upstream assets, including depleted reservoirs and offshore infrastructures strategically distributed in the North Sea and Mediterranean regions. This allows for the delivery of projects both in a timely and cost effective manner.

An additional element of this strategy is the strong R&D and technical capabilities to support emitters in the selection of the most effective capture solutions. They are identified among a wide technology portfolio that relies on strategic collaborations with leading technology providers as well as on our own proprietary technologies.

BENEFITS

- Full in-house competence along the CCUS value chain
- Strategic distribution of depleted reservoirs in the North Sea and Mediterranean areas near industrial emitters
- Cost-effective storage solutions through repurposing of existing infrastructures
- Demonstrated competency to manage complex projects from our long successful track record in the O&G industry
- Strong R&D capabilities to unlock value from capture & utilization technology portfolios
- Proprietary technology and tools for modeling and monitoring

DESCRIPTION

CCUS PROJECT PIPELINE IN ENI

Eni has decades of experience in the storage of natural gas in depleted fields and is applying its experience and expertise to repurpose existing infrastructure into permanent carbon dioxide storage hubs to decarbonize both its own industrial activities and those of 3rd parties.

In Norway, Eni is partner of Sleipner, the first CCUS project in Europe, successfully in operation since 1996. In the United Kingdom, Eni is the T&S Operator of the Hynet North West consortium, which has been selected by the government as one of the two priority CCS projects that will contribute to the Country decarbonization strategy. Hynet is on track to be ready to start operation in 2025 with the capability to inject 4.5 Mtpa (potential up to 10 Mtpa after 2030) in depleted gas fields offshore Liverpool Bay.

In Italy, Eni is developing the CCS Ravenna Hub project in a joint venture with Snam. Located off the coast of Ravenna and based on the large capacity of depleted gas fields in the Adriatic Sea, this will be the first CO₂ storage project in Italy and potentially the largest one in the Mediterranean Area. Phase 1 of the project, already authorized by Italian authorities, will start operations in 2024 with 25 ktpa capacity. The industrial phase, with an injection capacity of 4Mtpa and a potential expansion to over 10Mtpa after 2030 is scheduled to start in 2026.

Outside Europe, Eni is evaluating other CCS opportunities in Libya, Egypt, Algeria, and Australia. Globally all these projects will store a gross volume of carbon dioxide of around 30 Mtpa in 2030.

CAPTURE

Carbon Capture is the most significant element in terms of costs along the CCUS chain: 60-70% of the total cost.

Hence, while there are several well proven technologies that have been applied for decades, improved processes as well as innovative solutions are being developed at global level with the purpose of cost optimization.

To be able to address the widest possible range of industrial emissions, Eni is developing proprietary separation technology as well as monitoring and incorporating in its technology portfolio the different capture technologies that are commercially available or under development around the world.

Several activities have been carried out to de-risk the application of novel technologies, both through ad hoc experimentation in our labs and through collaborations and experimental campaigns in specialized R&D centers.

R&D areas of interest in capture technology are, among others:

- Absorption (e.g., amine, carbonate-based solvents)
- Adsorption (solid materials)
- Membranes separation

PROJECT PIPELINE

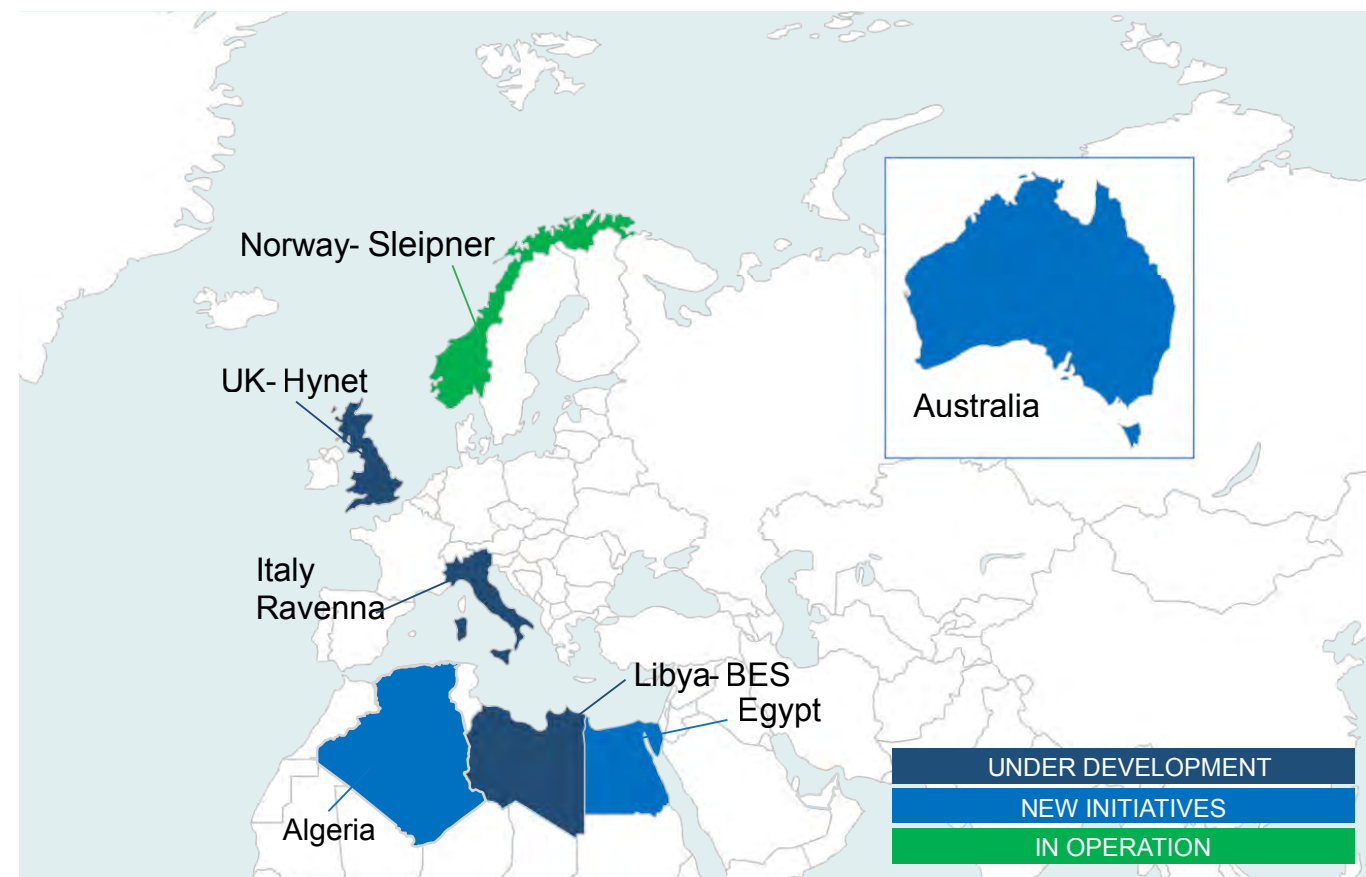

STORAGE

Eni's remarkable experience in exploration and field development has been transferred, in recent years, to CO₂ storage projects.

Eni's centralized G&G (Geological and Geophysical) technical services can provide advanced technologies and methodologies, which are strictly linked to high-level competencies and commitment towards innovation. The very same approach is applied to CO₂ storage projects. The re-purposing of competences from O&G exploration to CCS is based on a solid knowledge of how integrated specialistic studies should be carried out.

This starts from seismic processing, imaging and inversion, activities where Eni can take advantage of one of the most powerful HPC machines in the industry. Eni G&G workflow includes rock physics modeling, sedimentological studies, structural and fault seal analysis, basin-scale migration, using commercial and proprietary software as e-SimbaTM. All the specialistic studies are carried out internally, maximizing the communication between the different technical teams and project management. The adopted multidisciplinary approach to characterize the storage complex through the subsurface modeling benefits from continuously updating the technologies.

Eni's consolidated experience in reservoir modeling has also been transferred to storage projects. To support this kind of analysis, Eni is increasingly using Echelon, the proprietary simulator developed to exploit all internal HPC capabilities. In the framework of CO₂ injection modeling, further functions are under implementation in order to accurately consider all the processes that take place when CO₂ is injected in the porous medium.

The modeling of CO₂ storage in depleted fields requires additional input data for the geochemical-mineralogical characterization of rocks and fluids. Eni has developed a multidisciplinary workflow that integrates laboratory tests (i.e., ageing experiments at reservoir conditions) and numerical procedures (i.e., thermodynamic parameter estimation) to identify, model, and quantify the main reactive processes induced by exogenous CO₂. The approach can also be used for investigating the sealing efficiency of cap rock by integrating geochemical analyses with fluid breakthrough pressure tests and geomechanical tests.

Eni has developed subsurface characterization and modeling workflows that integrate laboratory analysis with static, dynamic and geomechanical modeling.

Starting from a 3D fluid-dynamic model, validated through historical data, specialistic studies are implemented to guide the definition of the optimal injection profile. The complete interdisciplinary simulation workflow includes:

- geomechanical studies to assess thermal effect due to the injection of a cold fluid within a warm formation
- geomechanical studies for fault stability caprock integrity evaluations

- geochemical studies to assess the effect on petrophysical properties and injectivity during the injection period
- flow assurance analysis to assess the bottom hole temperature and the well head conditions, to properly design the full CO₂ supply equipment (well-heads, flowlines, compressors).

UTILIZATION

Eni is developing a proprietary technology for CO₂ utilization through mineralization. The basic principle is a spontaneous process in nature. Silicate minerals containing magnesium, calcium, and/or iron react with CO₂ to form very stable, inert, and non-toxic carbonate phases, in which CO₂ is permanently fixed.

Eni has optimized the reaction conditions, reaching the complete conversion of the mineral in a short time. Therefore, the process could be suitable for an industrial application and the product could be used as a Supplementary Cementitious Material (SCM) in the formulation of cement.

Moreover, Eni is looking into e-fuels production as a complementary way of CO₂ utilization: green H₂ and CO₂ are combined to produce different kind synthetic carbon neutral fuels. In particular, Eni is currently developing a proprietary technology for SNG (synthetic natural gas) production: a pilot unit is about to be built and operated in an Italian industrial site in the frame of NextGenEU funding program.



MONITORING

In all CO₂ storage projects, whether they are in depleted fields or in saline formations, monitoring activities play a fundamental role, both to guarantee the effectiveness of CO₂ containment in the selected site and to comply with National and International directives. Regarding monitoring activities, Eni has twenty years of expertise in the sector, related both to the use of proprietary technologies and or testing innovative technologies through the direct cooperation with innovative service suppliers.

In this direction, the Eni's Monitoring strategy is based also in the development of proprietary instruments, as follow:

- MMV multidisciplinary workflow;
- E-VPSTM: Vibroacoustic Pipeline Monitoring System (patented technology, developed in house R&D project);
- Clean Sea: patented offshore hybrid AUV/ROV system, for simultaneous environmental and asset integrity inspections;
- Well Monitoring: several internal R&D projects are in place, aimed to monitor well integrity, well performance and plume migration.

The monitoring plan is a fundamental document, which reports the actions to be followed throughout all project phases, including the preliminary phase, the injection period and the post-injection period.

The MMV refer to the Risk Assessment and also contain references regarding the closure and post-closure plans.

Typically, Eni's monitoring approach has been developed with the aim to ensure:

1. The ability to compare on field measurements with data provided by static and dynamic models;
2. Identify any significant on field evidence;
3. Detect any CO₂ migrations and/or losses;
4. Detect any significant negative effects on the surrounding environment, and in particular on drinking water, human population and users of the surrounding biosphere;
5. Evaluate the effectiveness of any corrective measures taken.

The monitoring plan is designed according to the following principles:

- Compliance with existing legislation: the monitoring plan must comply with regulatory requirements.
- Risk-based: Monitoring activities are identified through a systematic risk assessment. The scope and frequency of monitoring activities depend on the outcome of the risk analysis.
- Site-specific: Monitoring technologies are selected for each monitoring task based on the result of site-specific feasibility assessments and then custom-designed to ensure optimal monitoring performance under specific storage site conditions.
- Adaptive: Storage site performance and monitoring systems are continuously evaluated and updated.

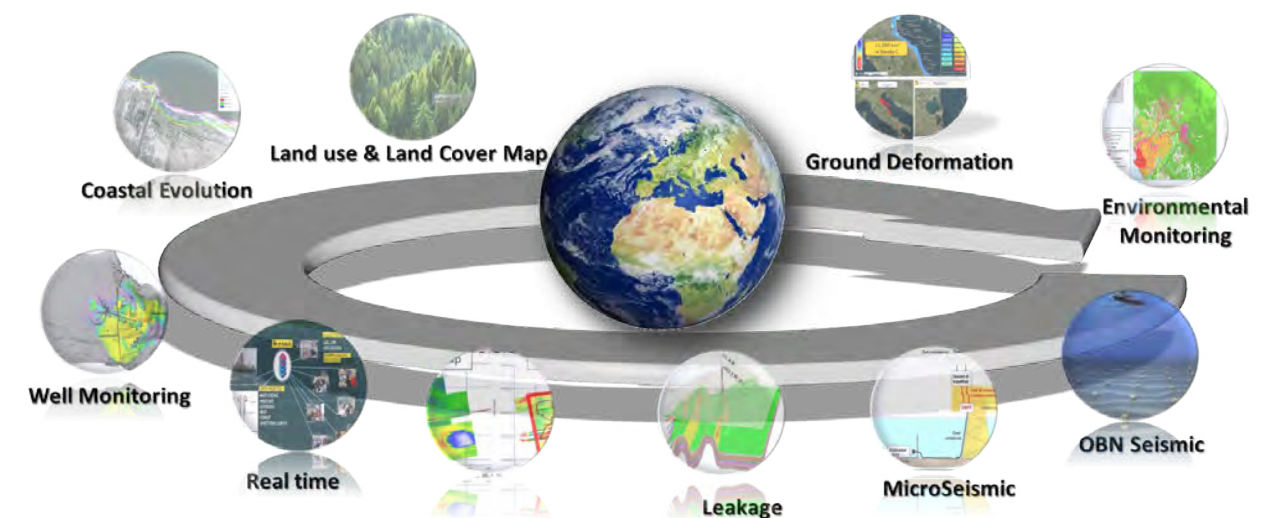

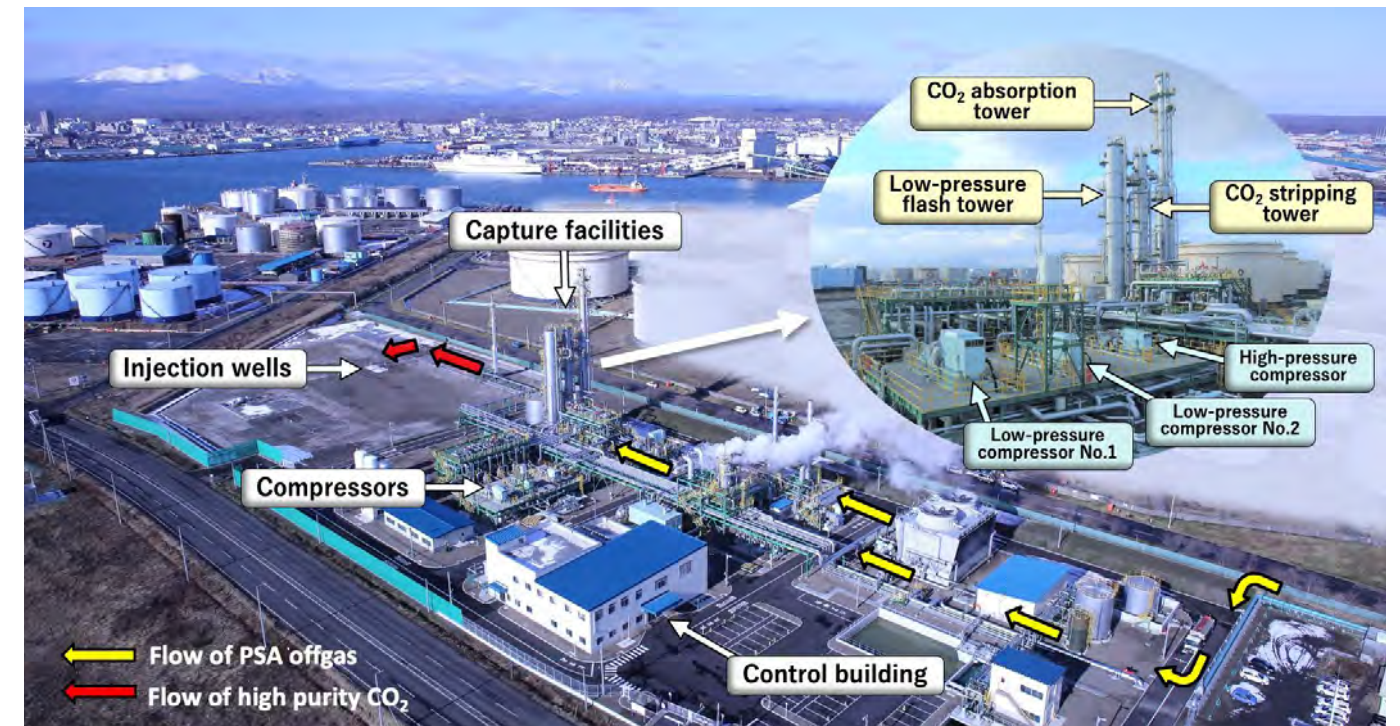

Fig. 1 Bird's-eye View of capture and injection facilities of the Tomakomai Project

STORAGE

JAPAN CCS CO., LTD.

SUMMARY

Japan CCS Co., Ltd. (JCCS) was founded in May 2008 when a group of major companies with expertise in CCS-related fields, including electric power, petroleum, oil development, and plant engineering, joined forces to answer the Japanese government's call for development of CCS technology.

JCCS has been conducting the Tomakomai CCS Demonstration Project, Japan's first full-chain CCS demonstration project in Tomakomai City, Hokkaido Prefecture, Japan since JFY2012 (JFY: Japanese fiscal year from April to March). The project was commissioned to JCCS by the Ministry of Economy, Trade and Industry (METI) between JFY2012 and 2017, and from JFY2018 by New Energy and Industrial Technology Development Organization (NEDO) with subsidies from METI.

The main objectives and tasks of the project are as follows:

- Demonstrate a full-chain CCS system from capture to storage
- Demonstrate that the CCS system is safe and reliable

BENEFITS

JCCS can share the following knowledge and experience acquired from the Tomakomai Project.

- Capture and compression technologies (excluding inherent knowhow belonging to the process licensor)
- Injection and monitoring technologies
- Public outreach experiences

- Remove concerns about earthquakes by the data collected by establishing:
 - No influence by natural earthquakes on CO₂ stored
 - No perceptible earth tremors induced by CO₂ injection
- Disclose project information and data and enhance understanding of CCS by local residents
- Acquire operational technology as well as strive towards practical implementation.

The target of 300,000 tonnes of CO₂ injection was achieved in November 2019. Post-injection monitoring is currently being conducted. No micro-seismicity or natural earthquakes attributable to CO₂ injection were detected in the vicinity of the injection area. The time-lapse monitor seismic surveys indicated clear anomalies reflecting the evolution of the CO₂ plume. The project is being conducted with the understanding and support of the local community.

DESCRIPTION

1. OVERVIEW OF THE TOMAKOMAI PROJECT

The Tomakomai CCS Demonstration Project is an offshore CCS project in Japan. The CO₂ source is offgas from an HPU (Hydrogen Production Unit) of an oil refinery located in the coastal area of the Tomakomai Port. CO₂ captured by an activated amine process is compressed and injected by two highly deviated injection wells drilled from an onshore site targeting two offshore reservoirs (Fig. 1).

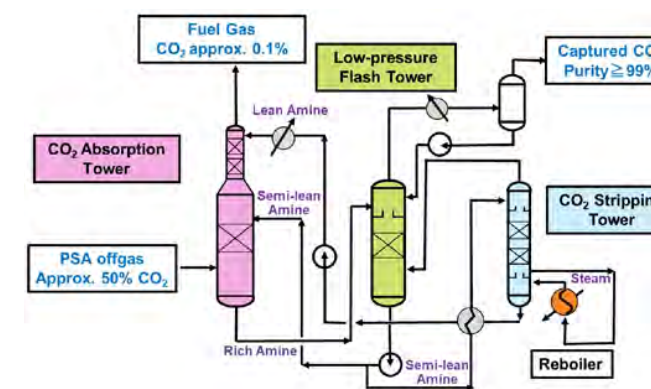

Fig. 2 Two stage absorption process

2. KEY RESULTS OF TOMAKOMAI PROJECT

2.1 CO₂ CAPTURE

The CO₂ capture process used in the Tomakomai project is a commercially proven amine scrubbing process (OASE[®] by BASF), and the capture facility is comprised of a two-stage CO₂ absorption tower, a CO₂ stripping tower and a Low-Pressure Flash Tower (LPFT), as shown in Fig.2. The maximum CO₂ capture rate is 25.3 tonnes per hour.

The two-stage absorption system shown in Fig. 3 results in a significant reduction of the amine reboiler heat consumption in the CO₂ stripping tower as only a small amount of semi-lean amine needs to be sent to the CO₂ stripping tower. The reboiler heat consumption was measured as approximately 0.9 GJ/t CO₂ or less, which is a significantly lower energy consumption than that of a conventional one-stage absorption system. The purity of the captured CO₂ was greater than 99% (dry basis) at the top of the LPFT.

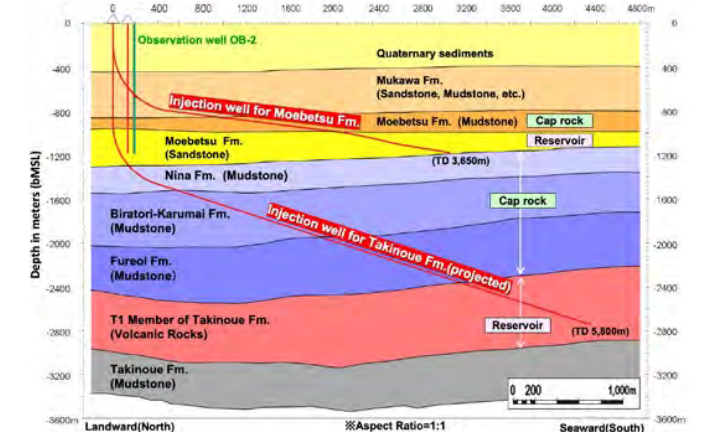

Fig. 3 Geological cross section

2.2 CO₂ INJECTION AND MONITORING

A geological cross section is shown in Fig.4 with profiles of the deviated injection wells. The Tomakomai project targets two independent reservoirs of different depths and different lithofacies; the Lower Quaternary Moebetsu formation at about 1,000 to 1,200 m in depth and 3 km off the coastline, and the volcanic and volcanoclastic layers of the Miocene Takinoue formation at about 2,400 to 3,000 m in depth and 4 km offshore.

Onshore monitoring facilities were comprised of a seismic station and three observation wells with pressure and temperature sensors and seismic sensors. Offshore monitoring facilities were comprised of an OBC (ocean bottom cable) with 72 seismic sensors and four OBSs (ocean bottom seismometers).

The facilities were deployed as shown in Fig.5 and started operation on February 1, 2015, thirteen months before the start of CO₂ injection. CO₂ injection into the Moebetsu formation began on April 6, 2016 and was terminated with the cumulative amount at 300,012 tonnes on November 22, 2019. CO₂ injections into the Takinoue Formation were conducted from February 6 to February 23, 2018, and from July 31 to September 1, 2018. The injectivity of the Takinoue formation was much lower than expected, and therefore the cumulative injection of CO₂ was 98 tonnes.

To date, no seismicity attributable to CO₂ injection has been detected in the vicinity of the reservoirs (Fig.6). Seismic surveys at cumulative CO₂ injection of approx. 65,000, 207,000 and 300,000 tonnes into the Moebetsu Formation detected anomalies, indicating evolution of the CO₂ plume (Fig.7). Seasonal marine environmental surveys have detected no indications of seepage of the injected CO₂.

As a result of an optimization study of the monitoring system and the marine environmental survey, some monitoring facilities and works have been discontinued after JFY 2021.

3. PUBLIC OUTREACH ACTIVITIES

As the project is being conducted close to the center of Tomakomai, a large industrial city including active fishing with a population of approximately 170,000, securing the trust of the local community through sustained communication, in particular with the local government and fishery cooperatives has been an important step in achieving the smooth delivery of the project. A key factor was the strong support of the city mayor and the local government, which formed the Tomakomai CCS Promotion Association in April 2010 (re-organized in October 2021 to Tomakomai CCUS/Zero Carbon Promotion Association), chaired by the mayor of Tomakomai and comprised of all the major local industries including the fishery cooperatives.

JCCS also places emphasis on removing concerns regarding earthquakes and securing trust in the safety of Japan's CCS technology through various public outreach activities such as forums for local residents, panel exhibitions, exhibits at environmental conferences, site tours, lectures, and experiment classes for schoolchildren. We have also maintained an information disclosure system in the city hall of Tomakomai.

3D view of hypocenters of events

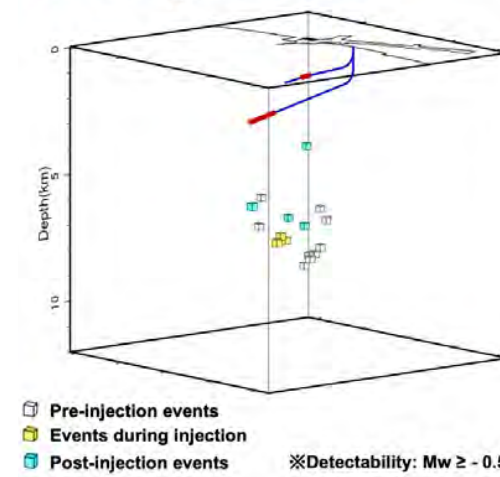

List of events

| Pre-injection events | | | | | Events during injection | | | | |
|----------------------|-----------------|----------------------|-------|--|------------------------------|-----------------|----------------------|------|--|
| No. | Date | Estimated Depth (km) | Mw | | No. | Date | Estimated Depth (km) | Mw | |
| 1 | 4/09/2015 15:03 | 6.64 | 0.14 | | 10 | 8/02/2017 13:35 | 7.80 | 0.50 | |
| 2 | 4/13/2015 14:00 | 5.97 | 0.14 | | 11 | 8/02/2017 13:36 | 7.78 | 0.33 | |
| 3 | 4/17/2015 07:06 | 8.17 | 0.20 | | 12 | 8/02/2017 13:55 | 7.70 | 0.33 | |
| 4 | 4/17/2015 07:09 | 8.19 | 0.19 | | | | | | |
| 5 | 4/17/2015 07:13 | 8.33 | 0.28 | | Post-injection events | | | | |
| 6 | 4/17/2015 07:18 | 7.57 | 0.17 | | No. | Date | Estimated Depth (km) | Mw | |
| 7 | 5/10/2015 08:27 | 8.59 | -0.04 | | 13 | 9/24/2020 11:53 | 5.86 | 0.59 | |
| 8 | 8/10/2015 19:08 | 6.76 | 0.23 | | 14 | 4/01/2021 04:23 | 7.45 | 0.23 | |
| 9 | 8/20/2015 23:20 | 8.18 | 0.44 | | 15 | 8/24/2021 16:03 | 6.50 | 0.13 | |
| | | | | | 16 | 9/18/2022 14:04 | 4.35 | 0.12 | |

Histogram of events

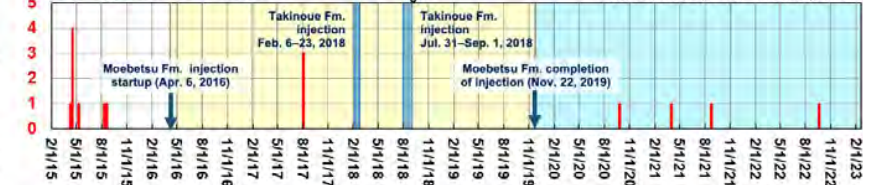

Fig. 5 Results of micro-seismicity of monitoring

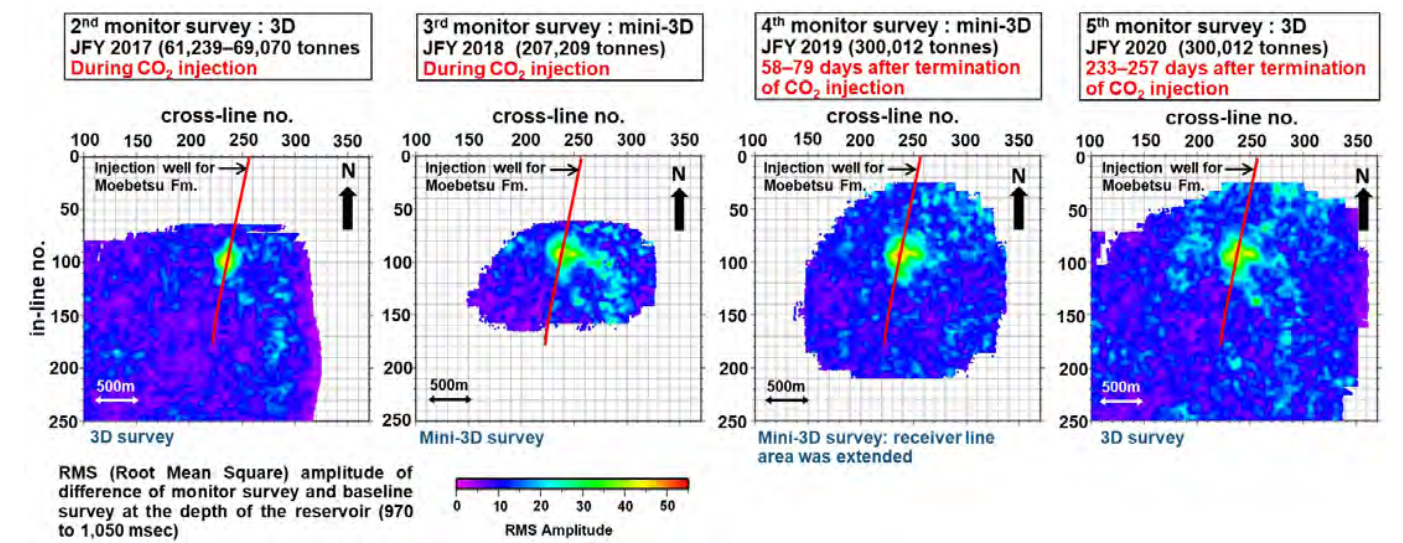

Fig. 6 Results of 3D seismic survey

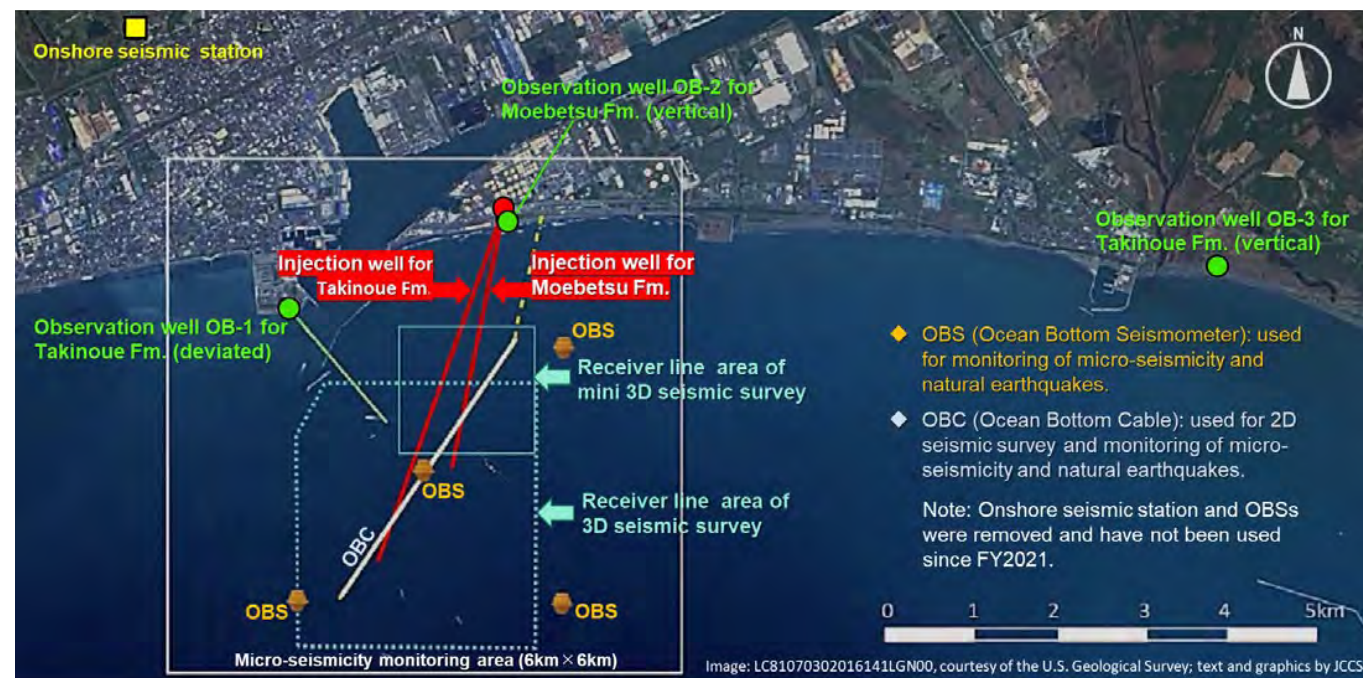

Fig. 4 Layout of monitoring system of the project



CONTACT

Email: PF-CCUSMarketing@nov.com

Web: www.nov.com



CARBON CAPTURE, UTILIZATION, AND STORAGE SOLUTIONS

NOV

SUMMARY

The transition to cleaner, carbon-neutral energy, coupled with the growth in decarbonization methods, is one of the most significant technological shifts to happen in modern history. Throughout our 150 years of experience at NOV, we have pioneered innovations that have enabled our customers to safely produce abundant energy while minimizing the environmental impact of their operations. The energy industry depends on our deep expertise and technology to assist in advancing the energy transition toward a more sustainable future.

We have joined the movement and our goal is simple: rejuvenate to improve upon what we already offer, repurpose technology and equipment traditionally used in oil and gas operations, and reposition the skills and knowledge from oil and gas toward the energy transition.

Carbon Capture, Utilization, and Storage (CCUS) is one initiative where our gas processing technologists and process system experts have been able to utilize their core competencies to design a carbon capture system for post-combustion flue gas. Within upstream oil and gas, our Wellstream Processing group is recognized as the global leader in delivering gas processing technologies and process systems. This expertise is cultivated from

our 35-year history of executing more than 350 complex gas treatment and conditioning projects in close to 50 countries worldwide.

Our post-combustion carbon capture technology is fully commercial, scalable, and adaptable to any flue gas application. This solvent-based post-combustion capture design utilizes a proprietary solvent that removes more than 90% of carbon dioxide. The scalability of our solution supports a wide range of applications and industries. We are actively engaged in performing and supporting carbon capture pre-FEED/FEED studies in a variety of flue gas applications including hydrogen, steel, power generation, oil & gas, paper and pulp, ethanol, waste-to-energy, and ammonia. We are reducing the cost of capture by deploying NOV's expertise in standardizing equipment packages and developing CO₂ point source specific product lines.

We are also involved in strategic partnerships to develop new carbon capture technologies that are focused on reducing the cost and improving the overall economics of implementing carbon capture. To address the challenges of implementing capture on smaller emitters below 100,000 tons per year, we are exploring new technologies

including adsorbent-based capture, new solvents, and novel configurations for solvent-based technologies.

In addition to our carbon capture technology, we design and supply gas dehydration and conditioning systems. Our diverse gas dehydration portfolio includes triethylene glycol (TEG) units, BASF Sorbead® adsorbents and molecular sieves adsorbents. We are uniquely positioned to select the most optimum CO₂ dehydration technology considering the dry CO₂ specification, and overall CAPEX and OPEX of these systems. This expertise has allowed us to successfully execute more than 100 gas dehydration projects globally which has enabled us to achieve high-energy recovery and low-glycol loss in our

glycol-based dehydration packages and modules, which are compact, lightweight, and small in footprint. We are developing the next generation of digitalized desiccant-based dehydration systems, enabling remote monitoring of operations which will enhance the desiccant lifetime, reduce energy requirements and OPEX of the system. Our CO₂ dehydration systems reduce the water dewpoint, preventing hydrate formation, condensation, and corrosion in the downstream processes. Other CO₂ conditioning packages include removing contaminants like oxygen, H₂S and Mercury and then compression for end use. We are also currently developing off-the-shelf engineered standardized modular dehydration packages.

BENEFITS

NOV is a one-stop-shop, offering capabilities to support throughout the entire value chain. These benefits include:

- Established execution and global supply chain models, featuring local, low-cost fabrication and decreased delivery times
- Experience in standardized system and equipment packages to drive efficiency
- Precision with large-scale projects, resulting in lower engineering design and project management
- Research and development activity to keep customers involved with the latest CCUS technology advancements
- Vast well construction capabilities for geological storage to streamline vendor operations

DESCRIPTION

Industry-leading solutions for CO₂ projects of any size are also available for transport, offshore offloading, injection, and storage. Our growing suite of automation, control, and monitoring solutions also support safe and reliable operations. A sampling of our solutions across CCUS includes:

- Our TK-Liner, GRE lined carbon steel pipe, delivers excellent corrosion protection in highly corrosive environments, as well as thermal insulation for downhole tubulars and flowlines.
- For more than 50 years, composite pipe has been used in CO₂ injection lines, high- and low-pressure pipelines, ductwork, WAG systems, and other challenging carbon capture and transportation applications. Our products are ideal for these critical applications due to their ability to handle concentrations of up to 100% CO₂. Composite solutions bring excellent corrosion resistance without the additional cost of cathodic protections or coatings traditional metallic materials require.
- Our energy efficient horizontal pumping systems are an ideal option to boost CO₂ pressure for pipeline entry. Tying into our variable frequency drive (VFD), users control the speed of the pump to adjust discharge pressure and flow rate, as needed. Additionally, automation, control, and monitoring solutions drive productivity and improve safety and reliability.

TRANSPORTATION

- For more than 80 years, Tuboscope has provided products and services that improve asset performance and maximize useful life. Our TK™-Corrosion control products and pipeline connection systems have successfully been used in CO₂ and carbon capture applications, efficiently transporting waste, preventing severe deterioration of line pipe and downhole tubing due to the corrosive nature of carbon containing wastewater.
- The proprietary suite of Tube-Kote™ coatings addresses all operating environments, providing superior corrosion protection, deposit mitigation and improved hydraulics. When used with our pipeline connection systems, the result is a continuous coated surface throughout the connection area and improved pipeline integrity and efficiency.



OFFSHORE OFFLOADING, INJECTION, AND STORAGE

- We assist customers with offshore CO₂ transfer, from terminal or storage vessel to shuttle vessel, shuttle vessel to storage facilities/well, or from shuttle vessel to storage and injection vessel. Transfer and mooring systems are important to secure vessels and ensure safe and reliable CO₂ injection offshore.
- Our Single Anchor Loading (SAL) and Submerged Swivel and Yoke (SSY) systems are used in shallow waters, while our Submerged Turret Loading (STL) system is used in deep water locations. The SAL system is designed for shuttling operations where continuous injections are not required, also known as batch wise injection. Alternately, the STL is suited for both shuttling and permanent mooring/continuous operation in deeper waters (50 m – 2500 m). The SSY is the preferable solution for permanent moored/continuous operation systems in shallow waters (15 m – 60 m). Technology choice and individual system complexity levels are also subject to specific seabed, soil, and weather conditions for the given terminal or storage aquifer/reservoir location.
- Our portfolio of dynamic high-pressure unbonded flexible pipes is compatible with CO₂. Already used in deep waters for CO₂ enhanced oil recovery injection (EOR), our offshore flexible pipes are equally applicable for injection into permanent storage.
- We also develop solutions for safe and efficient vessel integration of our technologies for CO₂ transfer interfaces, which include the Bow Loading System (BLS) and the Stern Discharge System (SDS). These high performing, field proven technologies have been used in the oil and gas industry for decades and are easily converted to CO₂ transfer in all three pressure and temperature levels considered for CO₂ handling.
- Our full suite of drilling technologies offers many solutions for drilling into saline aquifers or depleted oil and gas reservoirs for permanent CO₂ storage. We offer a complete suite of tubulars and bottom hole assembly (BHA) tools, as well as drilling optimization services.

RESEARCH AND TECHNOLOGY

We are home to multiple research and technology centers. Two of our facilities are specifically linked to NOV's low carbon initiatives, the Springett Technology Center located just outside of Houston in Navasota, Texas, and the Flotta facility in Orkney, Scotland located in the heart of the Orkney Net Zero Ecosystem. We can rapidly produce prototypes and test technology for customers with expanding capabilities to support more low carbon initiatives. Additionally, our lab services for low carbon supports environmental impact research, surveys, atmospheric monitoring, and permits.

As solutions to support decarbonization continue to evolve, NOV will remain at the forefront solving challenges and partnering with customers across the entire CCUS value chain. Please let us know if we can assist with your next project by emailing corporatemarketing@nov.com.

CCUS VALUE CHAIN INFOGRAPHIC

NOV technology supports the entire CCUS value chain.

- 1 Emission source
- 2 Carbon capture system
- 3 Onshore CO₂ injection well
- 4 Terminal for offshore CO₂ transportation
- 5 Transportation vessel
- 6 Vessel for offshore offloading and CO₂ injection
- 7 Re-purposed offshore platform for CO₂ injection
- 8 Offshore injection well for CO₂

CARBON CAPTURE SYSTEM

Our built-for-purpose carbon capture system is a solvent based, post-combustion capture design that removes more than 90% of carbon dioxide.

SUBMERGED TURRET LOADING

An optimal solution for deep water locations, our Submerged Turret Loading (STL) system is designed for shuttling and permanent mooring or continuous operation. Our STL ensures safe and secure injection offshore.

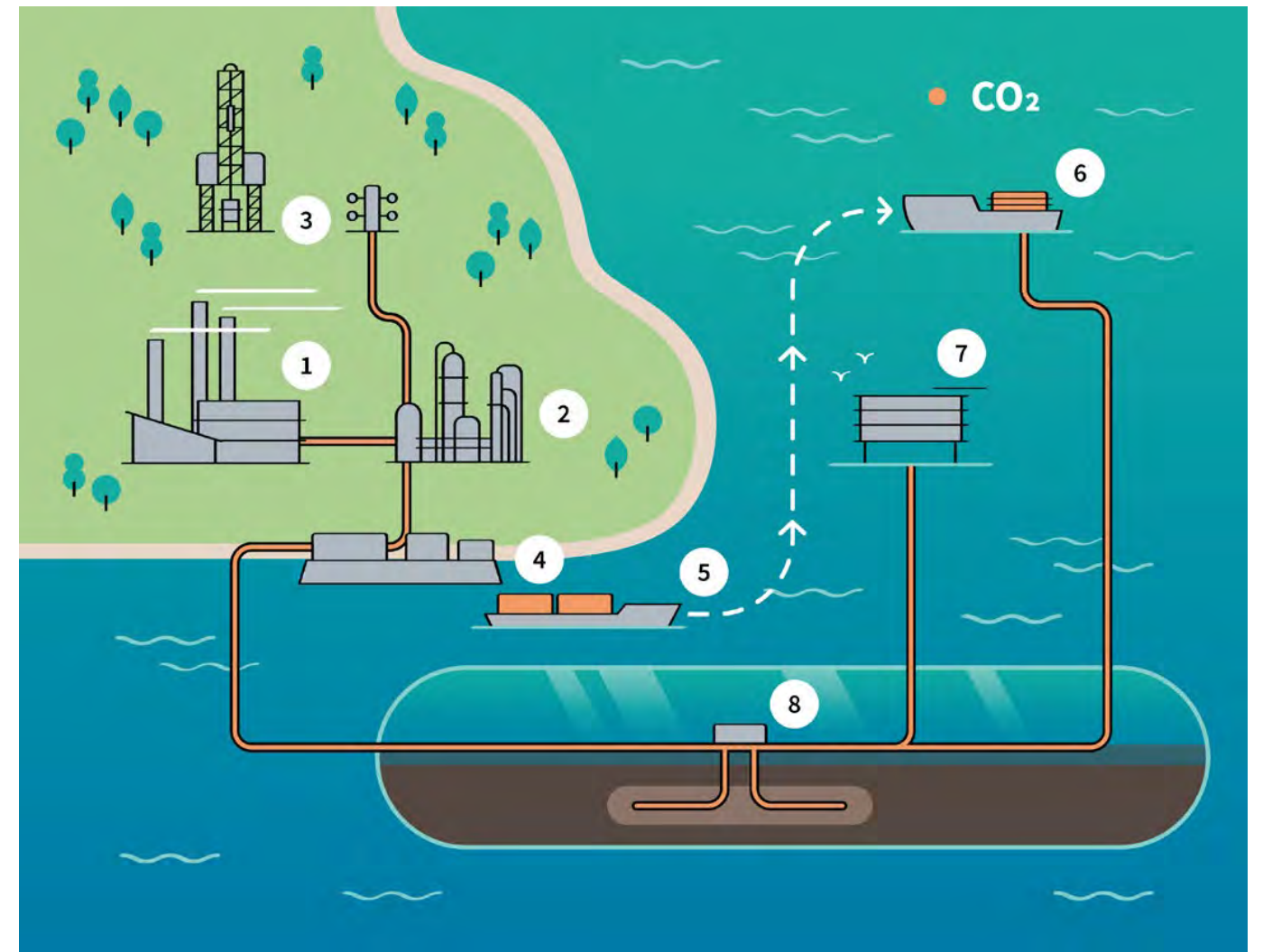

CCUS Value Chain Infographic



Carbon Capture System

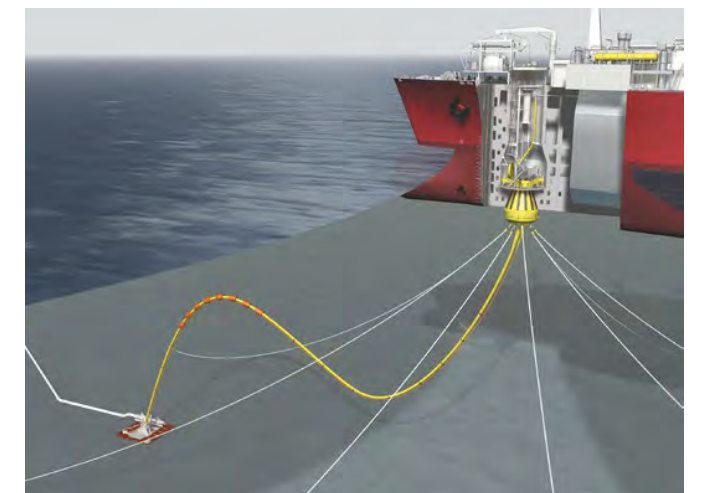

Submerged Turret Loading

PFLOTRAN-OGS

A reservoir simulator dedicated to CO₂ storage.

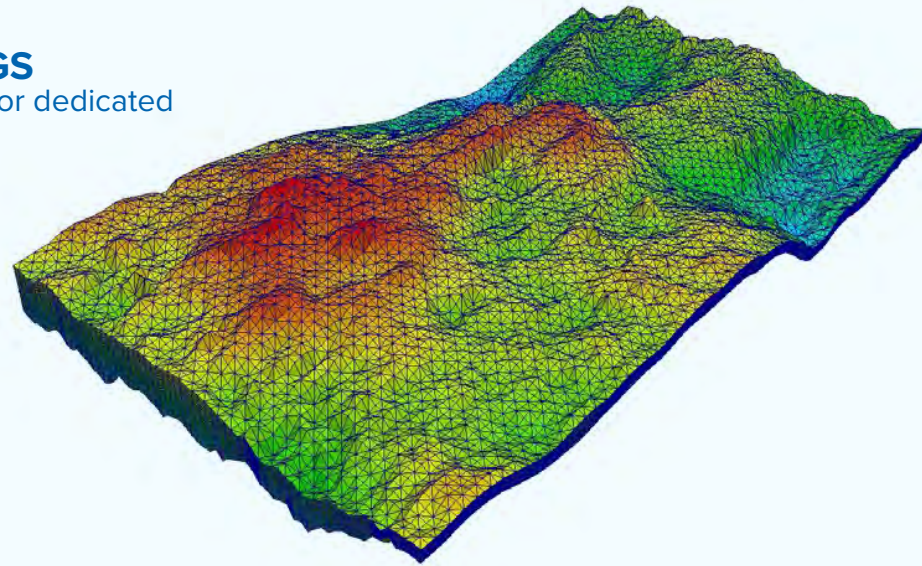

OPENGOSIM CO₂ STORAGE SOFTWARE SUITE

OPENGOSIM

SUMMARY

OpenGoSim (OGS) has developed PFLOTRAN-OGS, a reservoir simulation package centred on CO₂ geological storage. The simulator can model CO₂ storage in both saline aquifers and depleted hydrocarbon fields.

The documentation of the software capabilities and the user manual is available through the OpenGoSim website.

PFLOTRAN-OGS is open-source software that can be downloaded for free, and users can install and use it on their own without any support.

As the company that is developing and maintaining PFLOTRAN-OGS, OpenGoSim offers: (1) commercial support for an annual subscription fee, (2) a windows installer with pre- and post-processing capabilities and (3) a solution for cloud deployment.

BENEFITS

- Advanced modelling of CO₂ including thermal effects
- Well-established parallel-computing technology to speed up simulations
- Cloud technology to run models from your laptop
- No upfront license fees
- Affordable support packages

DESCRIPTION

Reservoir simulation is a key technology used in different phases of a CO₂ storage project. Early in the screening phase, models are built to estimate capacity, test critical operational parameters and eventually select a potential site over another. New simulation campaigns are typically run during appraisal and to create a project development plan. Finally, reservoir simulators are also used to estimate contingency and uncertainty for project costs and in determining plume migration conformance for storage site closure.

The OpenGoSim (OGS) software package provides simulation capabilities to predict the long-term effects of storing CO₂ in saline aquifers and depleted hydrocarbon fields. Engineers and researchers can run large-scale simulations to model the CO₂ migration and temperature change in detail. The simulator offers a number of accurate and easy-to-use built-in options to characterise CO₂ and its mixture with residual hydrocarbons, while modelling CO₂ dissolution in brine and temperature effects. It utilises mathematical models designed specifically for CCS applications, to improve efficiency and usability when compared to traditional reservoir simulators developed for hydrocarbon recovery and often readapted to model CO₂ storage. The software is highly scalable and can use a large number of computer processors to reduce the time needed to simulate large areas of the order of 100 x 100 km, for hundreds or thousands of years, as is often required by CCS studies.

The OGS project started in 2015 building on PFLOTRAN, an open-source software developed by the cooperation of several US national labs (Los Alamos, Sandia, Oak Ridge, Berkley, Pacific Northwest). PFLOTRAN was developed to enhance the understanding of a number of environmental problems, especially those that require long-term simulations and significant computational resources, such as nuclear waste management.

Thanks to support from Equinor, the UK government, and private investors, OGS has developed a reservoir engineering capability tailored to CO₂ storage, which now fits into the industry workflow, and has been used in several CCS projects across Europe with ongoing uptake in other regions. The core simulator remains open-source, facilitating cooperations with academia to accelerate R&D, while OGS has developed a front-end and an application to leverage cloud computing resources and to increase the simulator portability and usability. Beyond industry adoption, the software is being used by several universities worldwide and government institutes (e.g. British Geological Survey) in support of research activities, and lately has been selected by Imperial College and Cambridge University to commercialise some CCS-specific upscale techniques and reduced-physics models within the StrataTrapper project.

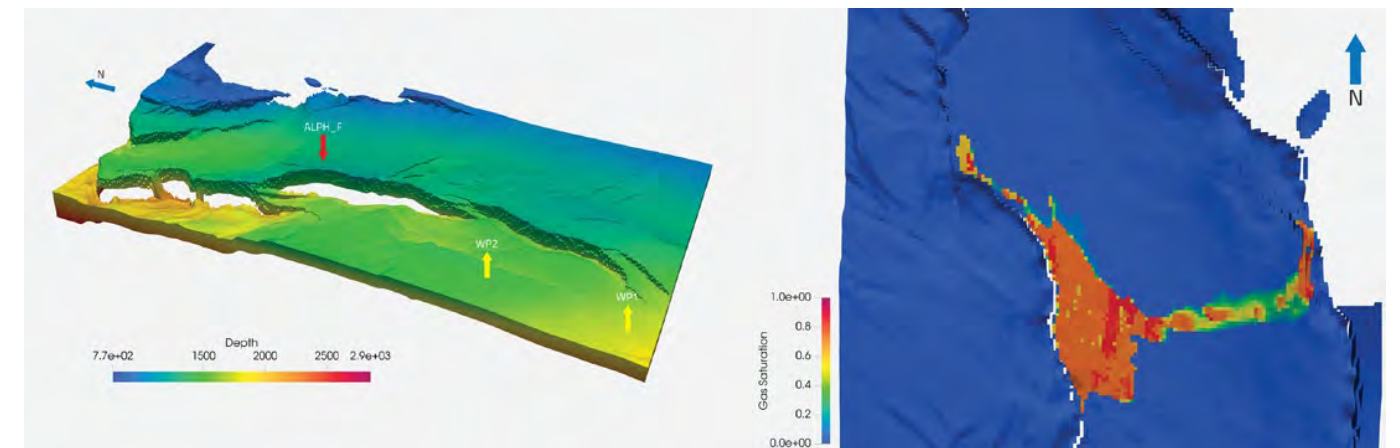

Smeaheia (Norway): CO₂ injection into a saline aquifer

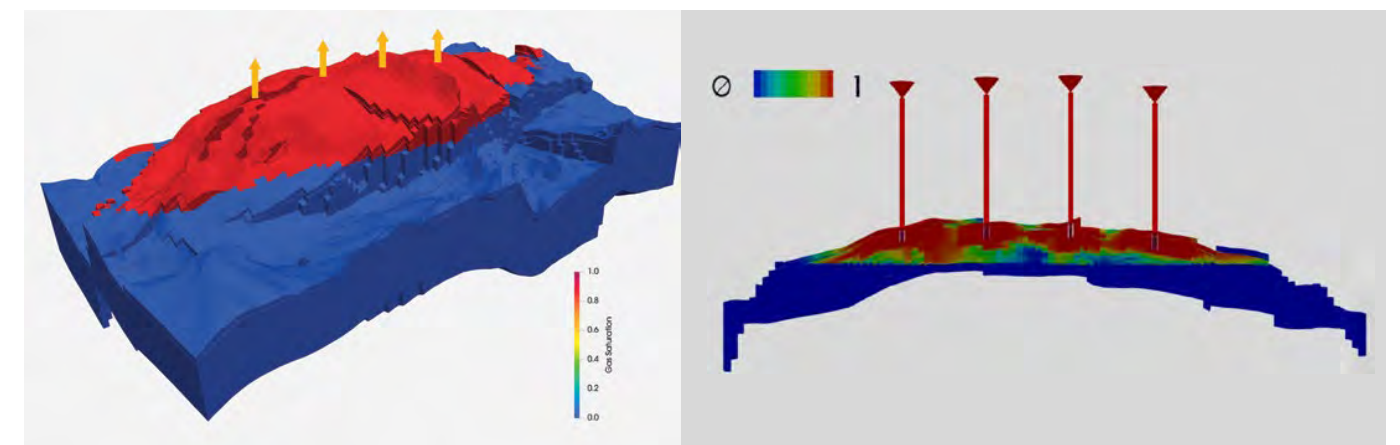

Hamilton (UK): CO₂ injection into a depleted gas field



INNOVATIVE CO₂ CAPTURE TECHNOLOGIES WITH CHEMICAL ABSORPTION, ADSORPTION, AND MEMBRANES

RESEARCH INSTITUTE OF INNOVATIVE TECHNOLOGY FOR THE EARTH

SUMMARY

The Research Institute of Innovative Technology for the Earth (RITE) is dedicated to developing innovative CO₂ capture technologies and to providing world-leading R&D and innovation results with a special focus on chemical absorption, adsorption, and the membrane separation process. Our research topics cover the development of new materials and innovative manufacturing processes and high-efficiency CO₂ capture systems. As for chemical absorption, the solvent developed in our project has been put to practical use in a commercial CO₂ capture process owned by a private Japanese company. For adsorption, pilot-scale tests of solid sorbents with good CO₂ desorption performance at low temperatures with adsorption systems are being conducted in collaboration with private companies using flue gas from coal-fired power plants. Recently, we started to develop new adsorbents for low-concentration CO₂ capture at natural gas-fired power plants with private companies. Furthermore, the direct air capture (DAC) process which captures CO₂ from the atmosphere is proceeded as a national project by RITE in collaboration with a private company to develop an innovative solid sorbent and effective capture system. With the target of separating CO₂ from a highly pressurized gas

stream using a low-cost, energy-saving process, we have been developing membranes and membrane elements. They are potentially applied in the integrated coal gasification combined cycle (IGCC) and blue-hydrogen production.

Efforts are also being made toward the standardization of CO₂ capture. As the only organization in Japan that is a member of the International Test Center Network (abbreviated as ITCN, a global association of facilities around the world that promotes the research and development of CO₂ capture technology), RITE regularly exchanges information with overseas ITCN members. In addition, we are conducting the project "Establish a common base for evaluating the standards of CO₂ separation materials," which started in 2022, and we have initiated the establishment of Japan's first real-gas test center at RITE.

These studies are based on results obtained from projects, JPNP13012, JPNP16002, JPNP18016 and JPNP21014 commissioned by the New Energy and Industrial Technology Development Organization (NEDO).

BENEFITS

- Useful CO₂ capture data using various amine compounds that have been accumulated over 20 years
- Liquid and solid absorption materials to effectively capture CO₂ using low-temperature steam
- Organic and inorganic membrane technology that can separate CO₂, alcohol, H₂O, H₂
- Materials for direct air capture (DAC) technology
- Membrane reactor technology for CO₂ utilization

DESCRIPTION

CHEMICAL SOLVENTS

We are developing novel amine solvents with energy utilization from low-grade waste heat. We succeeded in the development of amine solvents that could reduce the CO₂ capture energy by 40% compared with conventional amine solvents. Some novel amine solvents are in industrial use and have been adopted in two domestic commercial plants.

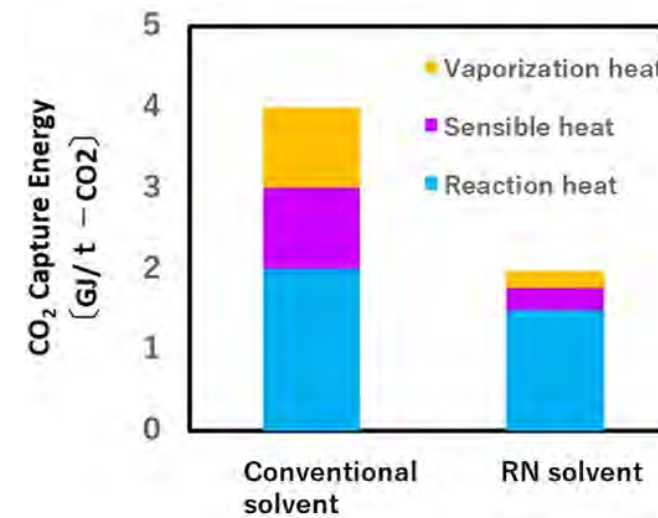

Industrial use second plant

MEMBRANE

We are developing organic membranes, such as molecular-gate membranes, and inorganic membranes, such as zeolite, silica, and palladium membranes. For organic membranes, we are working on a molecular-gate membrane module, which can separate and capture CO₂ from a mixed gas, including H₂ and CO₂, generated from the production process obtaining H₂ from hydrocarbons.

For inorganic membranes, we are working on separation between water and alcohol, CO₂ and CH₄, and MCH (Methylcyclohexane) and H₂.

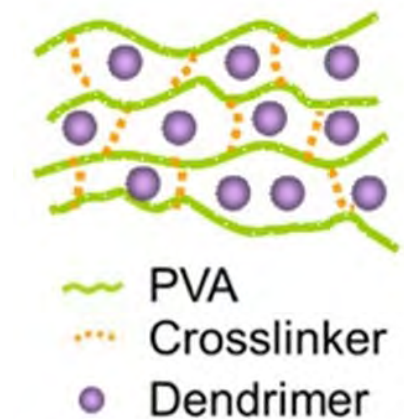

Molecular gate membrane

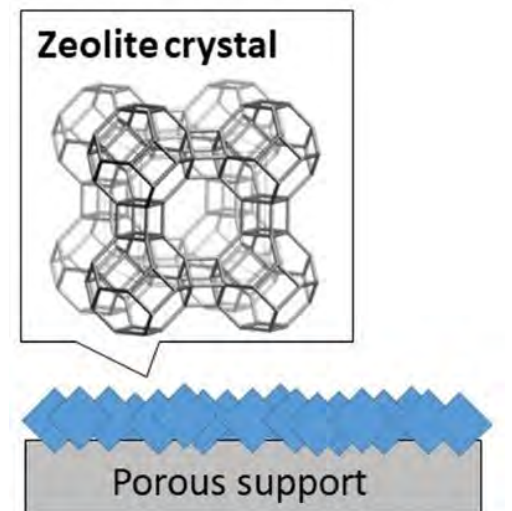

Zeolite membrane

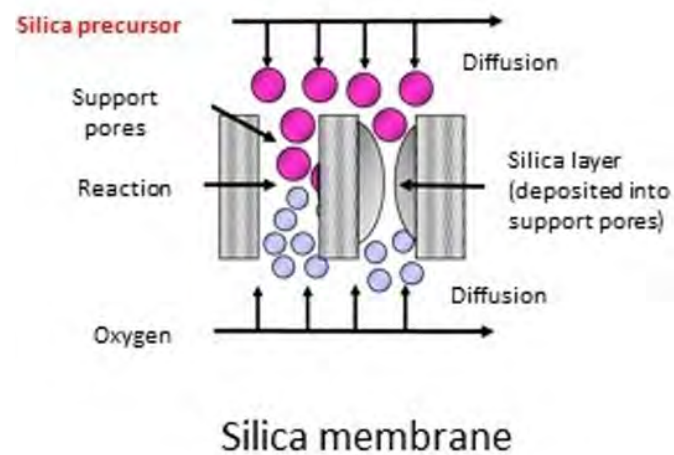

Silica membrane

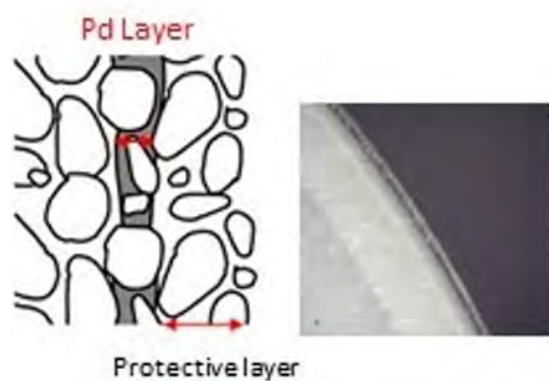

Palladium membrane

SOLID SORBENT

We are developing novel solid sorbents (porous sorbents modified with amines that are used in chemical solvents). Optimum amines and porous supports are chosen depending on the CO₂ concentration. We are working on effective CO₂ separation from coal-fired power plants (CO₂ concentration: around 13%), natural gas power plants (CO₂ concentration: around 4%), and the air (CO₂ concentration: around 0.04%).

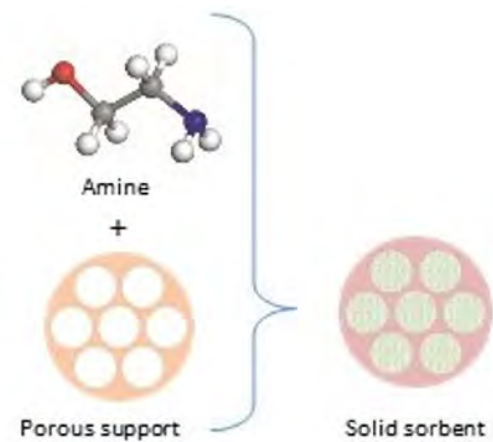

Development of CO₂ solid sorbent

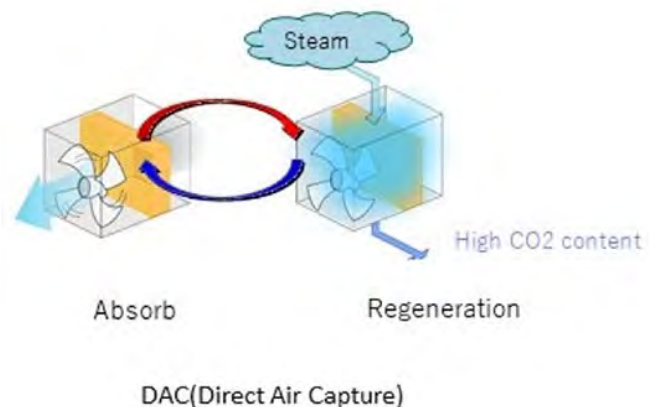

ESTABLISHMENT OF A COMMON EVALUATION STANDARD FOR CO₂ CAPTURE MATERIALS

We promote efforts to establish common evaluation standards for CO₂ capture technologies. We are developing standard evaluation methods for various CO₂ separation materials, while keeping pace with international trends in this field. In addition, we will found a real gas test center at RITE and support the development of CO₂ separation materials by domestic companies, research institutes, and others.

SCOPE

We will further actively participate in the development of technology for CO₂ separation and recovery, including chemical absorption, solid sorbents, and membrane separation. The chemical absorption process will be enhanced by the development of practical high-performance chemical solvents. For solid-sorbent-based technology, a pilot-scale test capturing 40t-CO₂ per day from flue gas at a coal-fired power plant has been scheduled for second half of FY 2023–2024, while a new project aims to develop innovative solid sorbents for CO₂ capture from natural gas power plants will be started. Regarding the DAC technology, we will accelerate its development toward a small-scale on-site demonstration at Expo 2025 Osaka, Kansai. As for membrane separation, in FY 2023, we will complete the fabrication of a prototype for a commercial-size membrane module and develop a plan for a field test, aiming to move forward into the development phase. About the Real Gas Test Center, its detailed design will be conducted in FY 2023. We will survey potential users to determine the key configurations desired and to make the center user-friendly for domestic researchers working on CO₂ separation materials. It will be open by the end of FY 2024.

In the future, RITE will be fully committed to the above-mentioned research topics. For carbon capture technologies in a stage very close to practical applications, we will conduct scale-up studies and tests under real-gas

conditions with the aim of establishing the technology at an early stage. In sustainable development scenarios for decarbonization, negative emissions technologies, such as DACCS (direct air capture with carbon storage), are expected to make significant contributions. Therefore, it is necessary to handle these low-concentration CO₂ emission sources. As the CO₂ concentration decreases, the amount of gas to be treated increases, and the oxygen concentration also increases. The development of materials at low cost with superior stability and a corresponding system is highly important. We will accelerate the development of these technologies so that we can implement low-cost, energy-saving CO₂ capture technologies into our societies as soon as possible. Efforts will also be devoted to effectively use the captured CO₂. We will develop the technology of CO₂ fixation into carbonates using steel slag and waste concrete and explore technology for recycling CO₂ into fuel and chemical feedstocks.



PRACTICAL TECHNOLOGIES FOR CARBON DIOXIDE GEOLOGICAL STORAGE

RESEARCH INSTITUTE OF INNOVATIVE TECHNOLOGY FOR THE EARTH

SUMMARY

Research Institute of Innovative Technology for the Earth (RITE) has been engaged in the research and development of carbon dioxide (CO₂) geological storage for a quarter of a century. We have conducted Japan's first CO₂ geological storage project in the 2000s and set the stage for the feasibility of CCS through fundamental research on monitoring technology, analysis, and prediction of CO₂ behavior in geological formations based on observational data and analysis of rock properties. In the first half of the 2010s, the fundamental technologies for CCS were developed, and in the latter half of the 2010s, technological

development was promoted with the aim of establishing technologies that can be utilized in commercial-scale projects.

For the implementation of CCS in society, it is important to establish not only technology but also social acceptance and improvement of the economy. Social acceptance of CCS is related to the possibility of induced seismicity and the environmental concerns. RITE provides various safety management technologies to reduce the risk of CO₂ geological storage, increase social acceptability, and improve the economy.

BENEFITS

- Procedures and detection technology to monitor offshore CO₂ leakage in case of emergency
- Operational control system to detect abnormal signs during CO₂ injection and prevent induced seismicity
- Optical fiber sensing technology to monitor CO₂ and reservoir conditions to ensure safe CO₂ geological storage
- CO₂ microbubble injection technology that drastically creates efficient CO₂ injection

DESCRIPTION

ADVANCED TRAFFIC LIGHT SYSTEM (ATLS)

There are concerns about earthquakes induced by the formation pressure increase from CO₂ injections. This has led CO₂ injection sites to undertake various monitoring activities such as seismic monitoring. To leverage the data acquired from these monitoring systems, the CO₂ storage research group has been developing a management system for CO₂ injections called the advanced traffic light system (ATLS). For hot dry rock geothermal power or enhanced geothermal systems (EGS), a traffic light system (TLS) has been developed to label a level of safety using traffic light colors, i.e., green, yellow, and red, judging by the observed data of microseismicity. The proposed ATLS is a system equipped with advanced functions to utilize data from all monitoring systems such as seismic observations at a CO₂ injection site and the injection status there.

The ATLS is designed to identify any irregularities as early as possible and send the feedback to the CO₂ injection operation. The system would enable the operator to control the CO₂ injection rates in accordance with the information provided by the ATLS and to undertake the necessary countermeasures.

The figure below illustrates a schematic view of the workflow of the ATLS. After obtaining the ground motion data, the extraction of the seismic events and the identification of their locations are automatically carried out. In parallel, the latest hypocenter catalog is

obtained from the Japan Methodological Agency (JMA) which is used to exclude the natural earthquakes from the catalog generated in the ATLS. Using the continuous observation data for two years or more in Tomakomai, it was demonstrated that the ATLS has the capability to automatically analyze the ground motion data and to locate each of the detected microseismic events at the injection point.

The frequency and locations of the micro- and natural earthquakes in the monitoring area and the colors of traffic light determined by the ATLS are displayed.

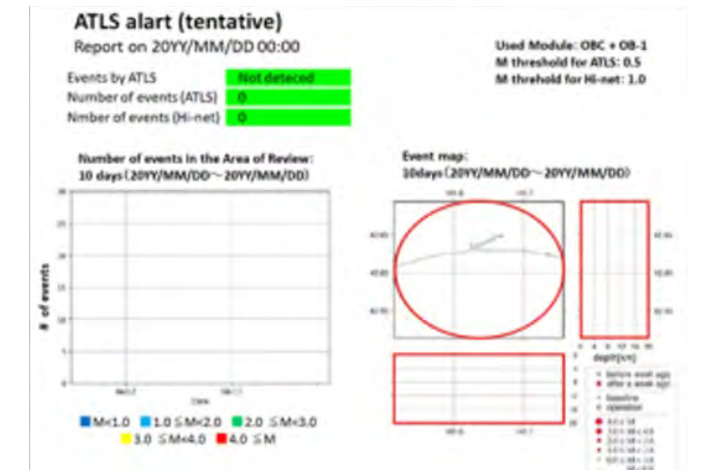

An example of the output from ATLS

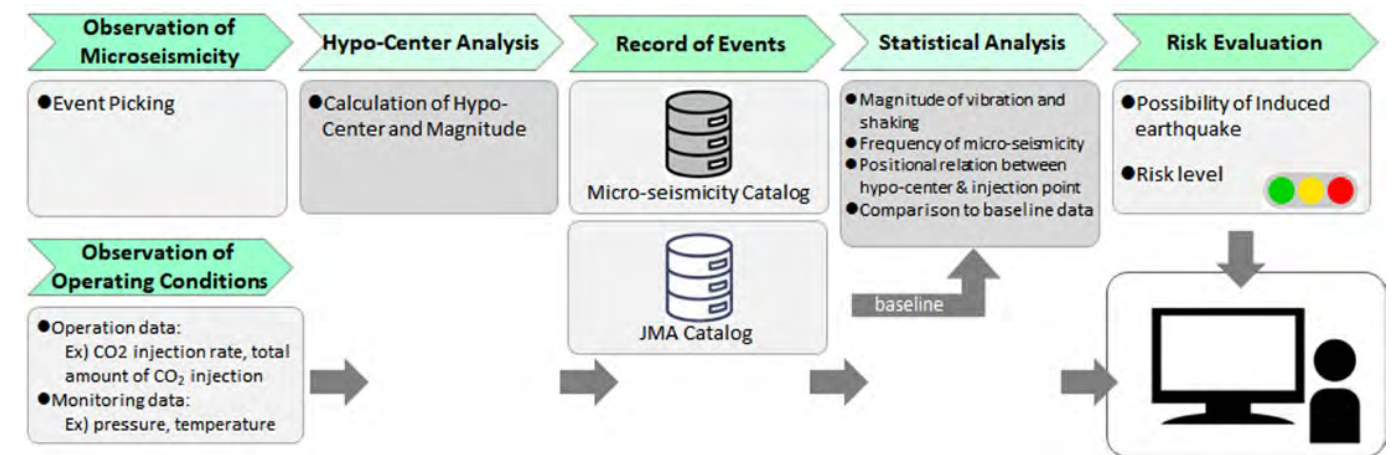

Flow diagram of ATLS

OPTICAL FIBER SENSING TECHNOLOGY

In geological CO₂ storage, it is essential to monitor not only the location of CO₂ plume but also the area of the pressure propagation. There are number of technologies suitable for such monitoring, for example, distributed fiber optical sensing (DFOS).

The DFOS system is capable of acquiring spatially continuous data and has been applied in various fields. The DFOS can act as a multi-sensor system to capture temperatures, pressures, strains, and vibrations simultaneously by installing multiple fibers together. The system is potentially considerably cheaper than a case where several sensors are installed.

- Distributed acoustic sensing (DAS)
 - Monitoring the CO₂ plume in the reservoir by using an optic fiber cable as a seismic sensor
- Distributed strain sensing (DSS)
 - Monitoring the geological stability of the reservoirs and cap-rocks by measuring the strain in the formations due to the pressure changes associated with the CO₂ injection
- Distributed temperature sensing (DTS)
 - Capturing the signs of a CO₂ leakage by monitoring the temperature changes around the injection wells and CO₂ pipelines

We have developed the DFOS system over several years and now demonstrate it in the fields in Japan and overseas, as shown in the figure below.

We have designed a noble optical fiber cable that contains multiple fibers filled with a resin substance in a stainless steel tube to overcome the installation challenges in the deep wells. The sensitivity of the hard steel cable was validated with the water injection test at the domestic site.

At the CCS site in North Dakota, USA, we demonstrated an integrated monitoring system using DAS, DSS, and DTS with the developed optical fiber cable. We monitor the integrity of the CO₂ pipeline and the injection/observation wells continuously to detect any potential damage to the apparatus. Furthermore, we monitor the injected CO₂ continuously using the DAS-vertical seismic profiling (VSP) system with permanent seismic sources.

At the pilot test sites in Australia, we are promoting demonstration tests of the DFOS system for fault monitoring. We monitor the CO₂ migration along/across the shallow faults and examine the fault stability at the deep faults.

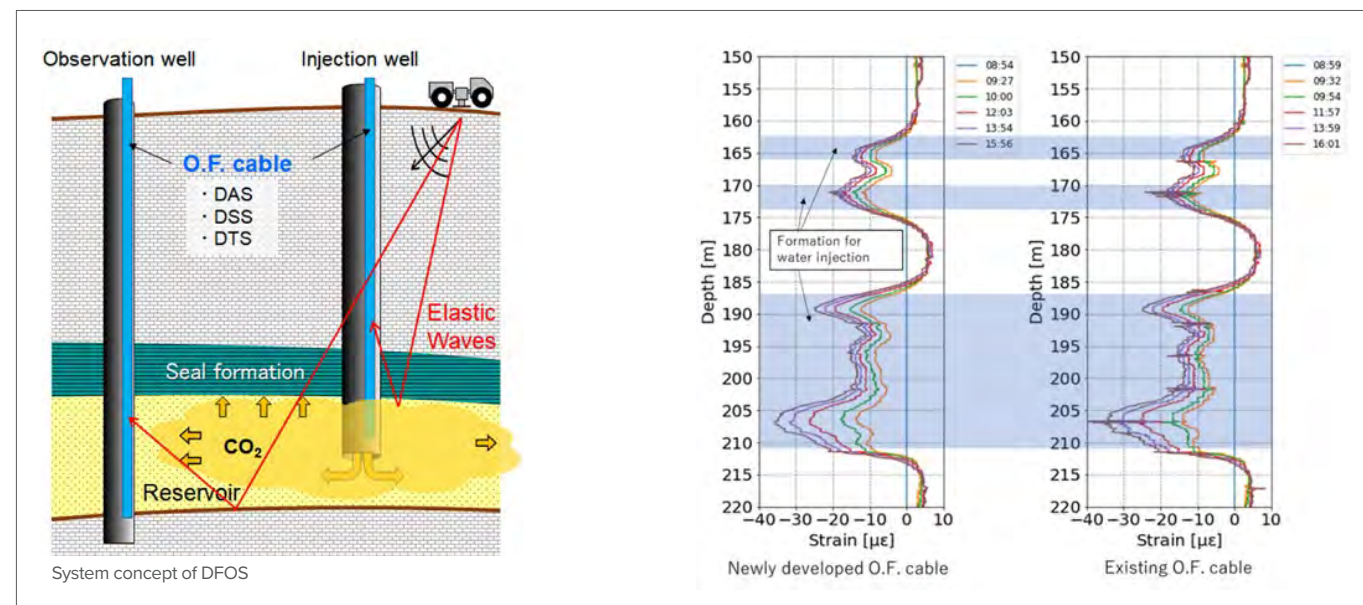

An example of formation strain measurement

MICROBUBBLE CO₂ INJECTION TECHNOLOGY

Microbubble CO₂ injection is a technology to generate microbubble CO₂ by supplying CO₂ into a special filter and to inject the bubbles into a pore space in formation. Using the microbubble technology, we have collaborated to improve CO₂ storage efficiency with Tokyo Gas.

The features of this technology have the potential to maximize the pore space utilization in geological CO₂ storage, use low-permeability formations that have not been considered storage formations, and enhance the oil recovery rates.

We, in collaboration with JAPEX, conducted a field test to examine the level of storage efficiency at their Sarukawa oil field in Akita. The selected formation was a 900 m deep sand formation, which bears oil. The oil is trapped in the formation with little natural flow. We did a Huff and Puff test, injecting CO₂ and water at a ratio of 9:1 and then pumping the formation fluid out.

The results are summarized in the table below. This shows that the microbubble CO₂ injection technique has the potential to improve the efficiency of the CO₂ injection, CO₂ storage, and oil recovery in comparison with the conventional methods.

| CO ₂ | CONVENTIONAL | MICROBUBBLE |
|-----------------|------------------------------|-------------------------------|
| Injection | 5.6t (0.6t/day x 10 days) | 20.0t (2.0t/day x 10 days) |
| Collected | 2.1t | 3.9t |
| Stored | 3.5t | 16.1t |
| Rate of Stored | 62% | 80% |

Results of the field test

INTO THE SEA

As CO₂ storage sites are deliberately selected to store CO₂ stably and safely, it is considered that CO₂ leakage from geological reservoirs is remotely possible. However, monitoring CO₂ behavior is essential as there are public concerns regarding CO₂ leakage. In addition, when storing CO₂ in the sub-seabed geological formations in Japan, it is mandated to assess the marine environmental impacts based on the supposition of the CO₂ leakage and to monitor and verify that there are no signs of CO₂ leakage or migration from the reservoir. To identify the signs of CO₂ leakage, the scope of monitoring should cover an extensive range from deep geological formations, including

storage complexes, to the sea. Reservoirs are generally at the depth of around 1 kilometer or deeper under the seabed. According to a simulation conducted previously, the amount of time that CO₂ migrates from a reservoir to the seabed right above would be more than 5 years. As the pathway of the CO₂ migration would depend on the characteristics of the formations between the reservoir and the seabed, the CO₂ would not necessarily leak into the sea in the area right above the reservoir. Taking this into consideration, we propose the following strategy for monitoring. Initially, we should direct the focus on the deep formations including the reservoir to detect signs of CO₂ migration from the reservoir. Then, if detected, we move to the in-depth investigation, targeting the overburden, to narrow the potential area for CO₂ to leak out. Finally, we prove a narrowed area to detect the signals of the leaked CO₂ in the water column.

The leaked CO₂ must be in the gaseous phase under the temperature and pressure conditions at the seabed of the shallow sea to ensure that CO₂ should not go out as bubbles from the seabed if it gets leaked. Monitoring to confirm that there are no bubbles from the seabed can be, therefore, an option for leakage monitoring.

Sonar is used extensively to detect bubbles in the sea and bubbles of gases such as methane. We have developed a methodology to use the side-scan sonar (SSS) technology, which is applicable in wide-area scanning to detect CO₂ bubbles. SSS is a tool to produce images of objects in the water column and topographic features of the seabed by emitting sonic pulses from both sides of the SSS to the vertical section perpendicular to the direction of its travel and receiving its reflection. We conducted an experiment to test whether the SSS can detect CO₂ bubbles released on the seabed under various conditions. Our findings demonstrate that the SSS is capable of detecting the bubbles released at a rate of higher than 2–4 tons per annum and that the distance between the neighboring observation lines in the monitoring should be shorter than the altitude of the SSS, i.e., the distance between SSS and the seabed beneath it.



Side-scan sonar used in the experiment

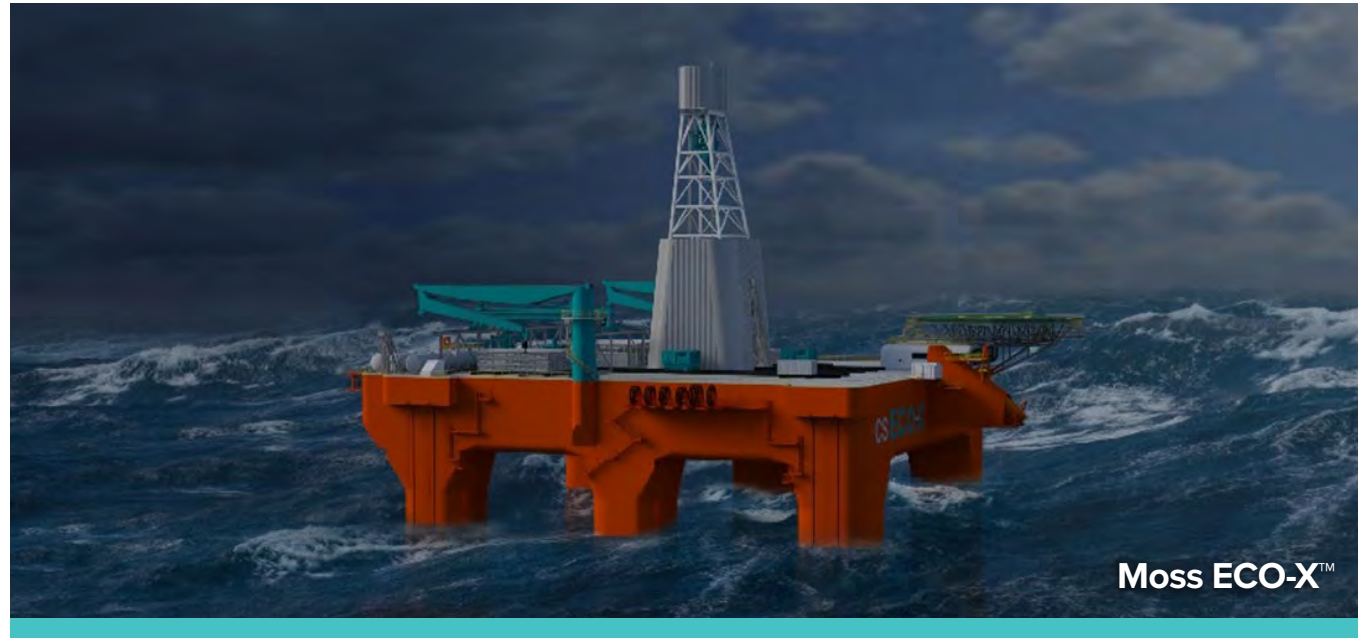

Moss ECO-X™

MOSS ECO-X™ SAIPEM

SUMMARY

Saipem is a global leader in the engineering, drilling and construction of large projects for the energy and infrastructure sectors and provides a full range of net zero-oriented services for its clients operating in both the energy transition and the offshore and onshore oil & gas sectors. Saipem is highly specialized in carbon capture, transport, storage and utilization and has a proven track

record in successful CO₂ projects. Saipem's subsidiary Moss Maritime has developed high-tech drilling units such as the Moss CS semisubmersible catamaran platforms perfectly designed for drilling operations of CO₂ injection wells. The company's experience includes successful onshore and offshore projects worldwide.

BENEFITS

- Field-proven drilling capability in the harshest and deepest environments
- Environmentally sustainable drilling operations with the Moss CS ECO-X™ semi-sub catamaran platform
- End-to-end capabilities in CO₂ storage projects
- Successful track record in both onshore and offshore

DESCRIPTION

DRILLING FLEET

Saipem owns and operates a world-class offshore drilling fleet capable of conducting drilling operations in the most challenging conditions. The fleet includes several high-tech and advanced drilling units, including the Moss CS semisubmersible catamaran platforms.

Saipem's offshore drilling fleet has the latest drilling technology, ensuring clients receive safe, efficient and reliable drilling services. The fleet is operated by experienced and highly skilled crews trained to handle the most complex drilling operations.

MOSS ECO-X™

Moss Maritime | ECO Drilling Floaters (mosswww.com)

The Moss CS-series of semisubmersible catamaran platforms is one of the world's most field-proven and successful platform designs for harsh environments, and the state-of-the-art ECO-X™ platform represents a quantum leap in the direction of more sustainable drilling operations.

The ECO-X™ is built with a focus on energy efficiency, reduced emissions, and improved safety, making it an ideal platform for drilling carbon storage wells in environmentally sensitive areas. The design features a state-of-the-art

hybrid power system, which combines diesel-electric and battery power to reduce fuel consumption and CO₂ emissions. Additionally, the platform is equipped with a high-performance drilling system and advanced safety and automation systems to ensure efficient and safe drilling operations.

The Moss CS has already been successfully utilized for well-drilling operations around the globe, demonstrating its effectiveness and reliability. Its advanced design and capabilities make it an ideal platform for carbon storage projects worldwide, helping to mitigate climate change by safely and efficiently storing CO₂ in geological formations.



Saipem Scarabeo 8, a last generation semisubmersible drilling rig



CO₂ SOLUTIONS BY SAIPEM

SAIPEM

SUMMARY

Are you seeking how to reduce your carbon footprint with low environmental impact and financial cost? CO₂ Solutions by Saipem technology into Bluenzyme modular products is the answer. These solutions use advanced enzymatic carbon capture technologies that catch CO₂ emissions from industrial processes, making them more efficient, cost-effective, and environmentally friendly than traditional methods. With a stable, non-toxic carbonate

solvent and enzymes as a catalyst, CO₂ Solutions by Saipem technology eliminates many risks associated with traditional carbon capture. Moreover, with Saipem's modular design and fabrication expertise, Bluenzyme ready-made products are cost-effective and sustainable.

Enable your energy transition today with CO₂ Solutions by Saipem technology and Bluenzyme modular products.

BENEFITS

- Non-toxic, non-volatile and stable carbonate solvent reducing environmental impact
- Solvent regeneration with low-grade residual heat at 80°C significantly reducing or eliminating thermal heat costs and providing higher efficiency
- Low-complexity process with fewer pieces of equipment, leading to lower CAPEX and OPEX costs and easy operation
- Elimination of operational and environmental risks associated with traditional amine-based solvents
- More tolerant to SO_x and NO_x than traditional technologies.

BLUENZYME PRODUCTS:

- Modular design for various industrial applications, including oil and gas, petrochemicals, power production and hard-to-abate sectors
- Utilization of CO₂ Solutions by Saipemw technology for efficient and sustainable carbon capture
- Reduced construction time and costs through modular fabrication
- Improved quality control and safety with standardized processes

DESCRIPTION

CO₂ SOLUTIONS BY SAIPEM TECHNOLOGY

CO₂ Solutions by Saipem is a cutting-edge technology that uses enzymatic carbon capture to capture carbon dioxide emissions from industrial processes. The post-combustion capture process involves three columns, each with a specific role in capturing and separating CO₂.

- Quench Tower: cools the flue gas, condenses much of the water vapour and manages particulates and contaminants.
- Absorber: captures the CO₂ in the solvent at near atmospheric pressure.
- Desorber: releases the CO₂ at high purity and regenerates the solvent at low temperature.

Enzymes play a vital role as a catalyst in the CO₂ capture process. The enzyme used in the process is known as carbonic anhydrase, which accelerates the reaction between CO₂ and water to produce bicarbonate ions. The carbonate solvent used in the process is simply water, potassium carbonate, and the enzyme. This solvent has unique properties that make it ideal for post-combustion CO₂ capture. One of its most important characteristics is its stability under oxidative conditions and in the presence of flue gas contaminants, eliminating the production of degradation byproducts. Additionally, the non-volatile solvent is non-toxic, making it safer to handle and dispose of than traditional amine-based solvents.

The St-Félicien first-of-a-kind carbon capture plant in Quebec, Canada, tested the CO₂ Solutions by Saipem technology. It captured over 90% of CO₂ emissions and confirmed the solvent's remarkable stability and low-temperature performance. The plant operated effectively under varying process conditions and flue gas compositions, thus proving the potential of the technology to mitigate greenhouse gas emissions.

Saipem's CO₂ Solutions technology has potential applications in various industries, including power generation, cement production, steelmaking and other hard-to-abate industries. By integrating with existing industrial processes, the technology can capture CO₂ emissions and reduce greenhouse gas emissions. Heat integration with the host site can eliminate thermal energy

costs and provide additional economic benefits. While further development and improvements are possible, such as increasing the scale of the process, the non-toxic and non-reactive nature of the enzyme and carbonate system used in the process makes significant technological improvements challenging. The robustness and resilience of the enzyme ensure the process's stability and efficiency over long periods.

BLUENZYME PRODUCTS

Bluenzyme is a revolutionary product line developed by Saipem that leverages the enzymatic carbon capture technology of CO₂ Solutions by Saipem.

Saipem's modular design and fabrication expertise makes Bluenzyme products a cost-effective and ready-made solution for industrial clients.

The benefits of modular design and fabrication include:

- Reduced construction time and costs: modules are built off-site in a controlled environment, with standardized fabrication processes and stringent quality controls, reducing in-situ construction time and costs.
- Reduced environmental impact: modular construction generates less waste and is more energy-efficient than traditional stick-built methods.
- Flexibility: modular units can be easily integrated within existing facilities with a Plug & Play concept.
- Improved safety: modular construction reduces the need for on-site work and improves safety conditions for workers.

Combining the benefits of CO₂ Solutions by Saipem technology with modular design and fabrication, Bluenzyme modular products offer a sustainable, cost-effective, and ready-made solution for reducing carbon emissions and improving operational efficiency. The technology's unique features, including enzymatic carbon capture and a stable, non-toxic and non-volatile carbonate solvent, make it a powerful and environmentally friendly alternative to traditional carbon capture methods.



Figure 1 – Industrially-proven CO2 Solutions by SAIPEM technology

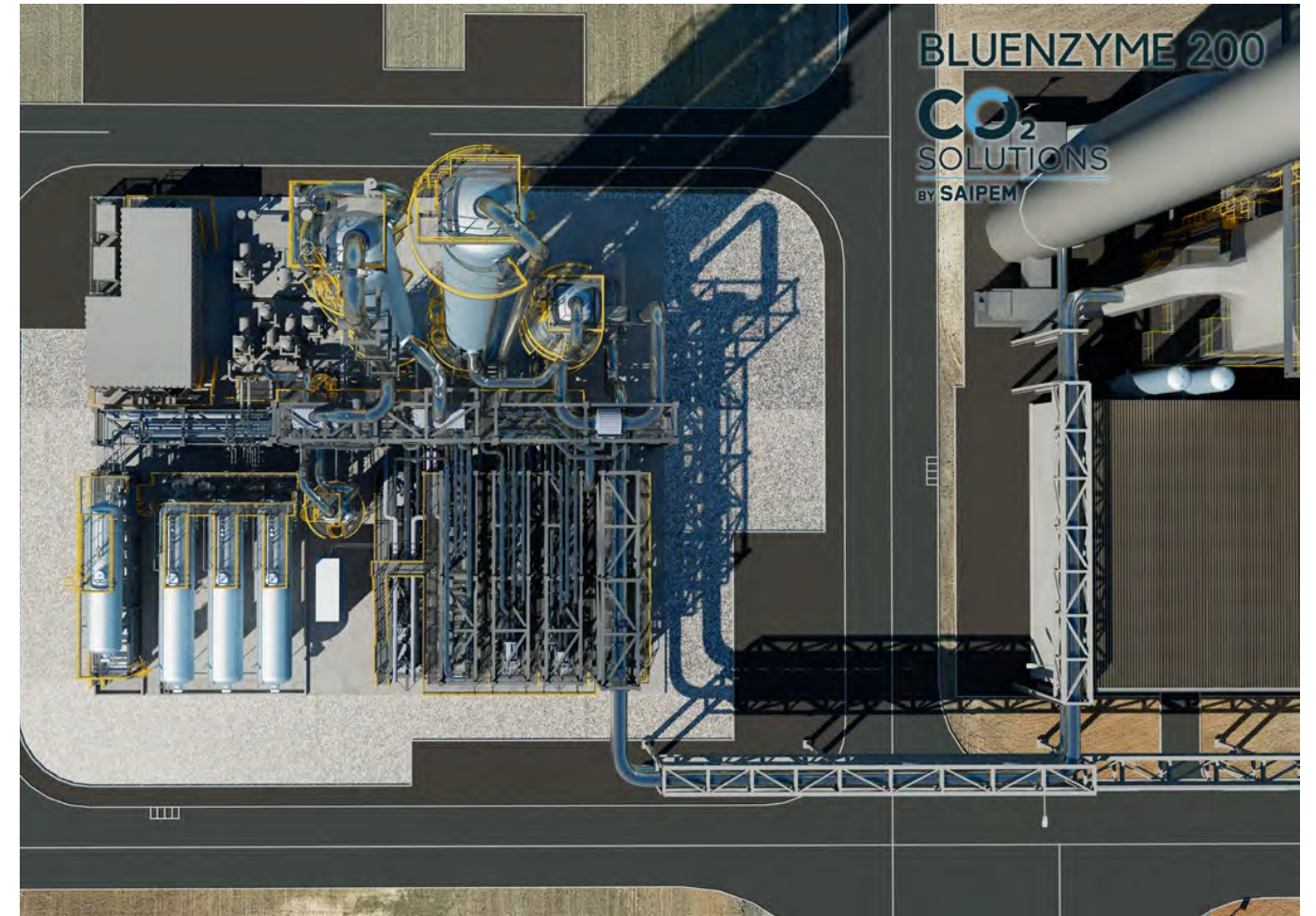

Figure 3 – Streamlined Efficiency: Bluenzyme 200, fully operational 18 months after order, features a 35m X 40m footprint inclusive of storage and E&I modules



Figure 2 – Bluenzyme products: Modular approach for quick execution



Figure 4 – Seamless Installation: The Bluenzyme modular unit – swift to deploy, exceptionally efficient, and environmentally sustainable.

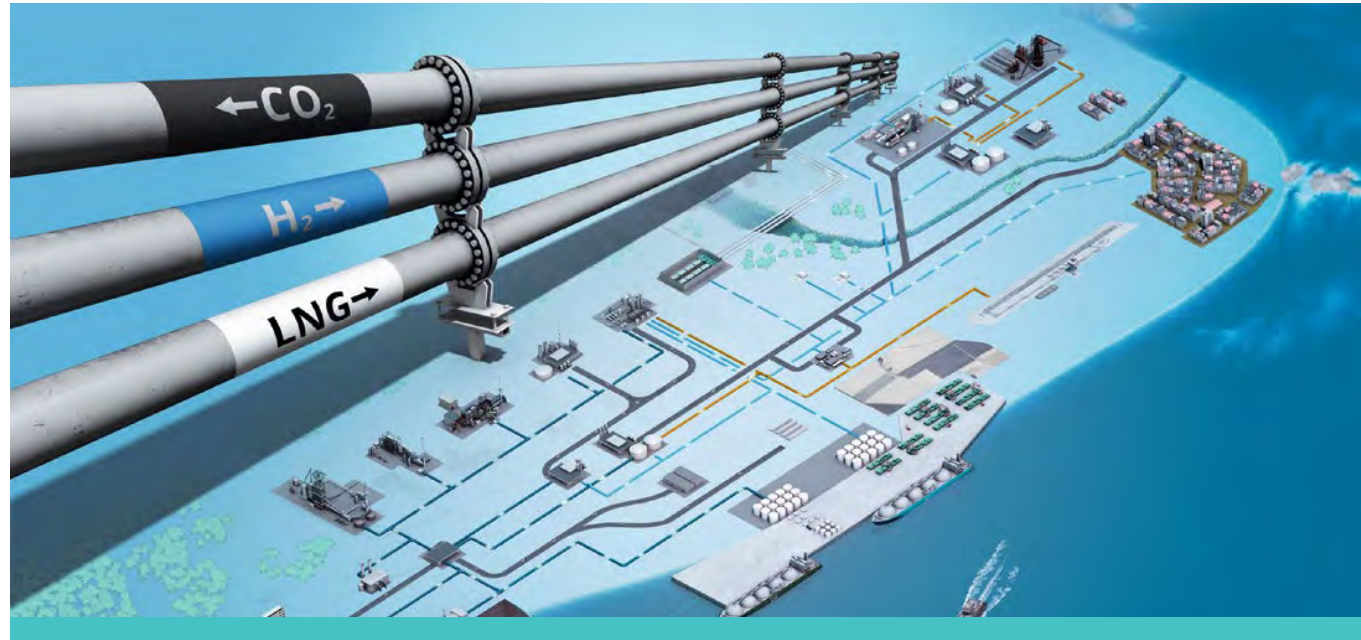

GAS ANALYSIS AND FLOW METERING FOR CCUS
SICK

SUMMARY

From factory automation to logistics automation and process automation – SICK drives industries with sensors. As a technology and market leader, SICK provides sensors and application solutions that create the perfect basis for controlling processes securely and efficiently, protecting individuals from accidents, and preventing damage to the environment.

Founded in 1946 by Dr.-Ing. h. c. Erwin Sick, the company with headquarters in Waldkirch, Germany ranks among the technological market leaders. With more than 50 subsidiaries and equity investments as well as numerous agencies, SICK maintains a presence all around the globe. In the 2022 fiscal year, SICK had more than 11,900 employees worldwide and a group revenue of around EUR 2.2 billion.

Sensor Intelligence. For all requirements.

When movement becomes collaboration, when industrial systems have to be flexible, and when clean solutions are the key, then customer can certainly benefit from SICK's many years of experience. As an innovation leader and pioneer in the development of groundbreaking sensor technology, we offer solutions that are already up to the

challenges of the future today. With intelligent sensor technology that collects data and evaluates it in real time, adapts to its environment and communicates in the network.

Process Automation

SICK's Process Automation division offers sensors and tailored system solutions as well as services for analysis and process measurement technology. When measuring emissions, they monitor the legally prescribed gas components, accurately record dust and particle emissions and measure volume throughput. The ultrasonic technology by SICK is one of the leaders in the precise flow measurement of natural gas in the pipeline distribution network as well as for process gases and steam. SICK's measurement technology solutions make a valuable contribution to resource-saving plant control in the primary industries.

Sensor solutions for CCUS

SICK already has solutions to support the complete CCUS value chain, when it comes to continuous gas analysis or CO₂ flow metering.

BENEFITS

- **CO₂ reporting and accounting.** Flow metering will become necessary for fiscal purposes, custody transfer and compliance with future regulatory measurements. SICK provides solid experience from thousands of custody transfer applications with natural gas. This experience can be transferred for each step of the CCUS value chain to ensure accurate flow measurement and precise reporting.
- **Process efficiency.** Carbon capture processes require a high degree of efficiency to improve their economic and environmental attractiveness. The measurement of CO₂ content and the remaining components after the capture process is essential for control and optimization purposes. SICK has more than 10 years of experience with pilot installations.
- **Quality control.** Regardless of the destination of the captured CO₂ (storage or utilization), it is important to control the quality of the gas and possible impurities that can have a negative influence on the later steps of the CCUS network and ensure protection of the environment.
- **SICK LifeTime Services.** SICK LifeTime Services is a comprehensive set of high-quality services provided to support the entire life cycle of products and applications from plant walk-through to upgrades. LifeTime Services range from product-independent consulting to traditional product services.

SICK creates innovations for a sustainable future!

We create completely new solutions in co-creation with our partners. Taking years of experiences from emission monitoring and gas flow measurement to overcome the challenges of precise and continuous monitoring and control of CO₂ value streams.

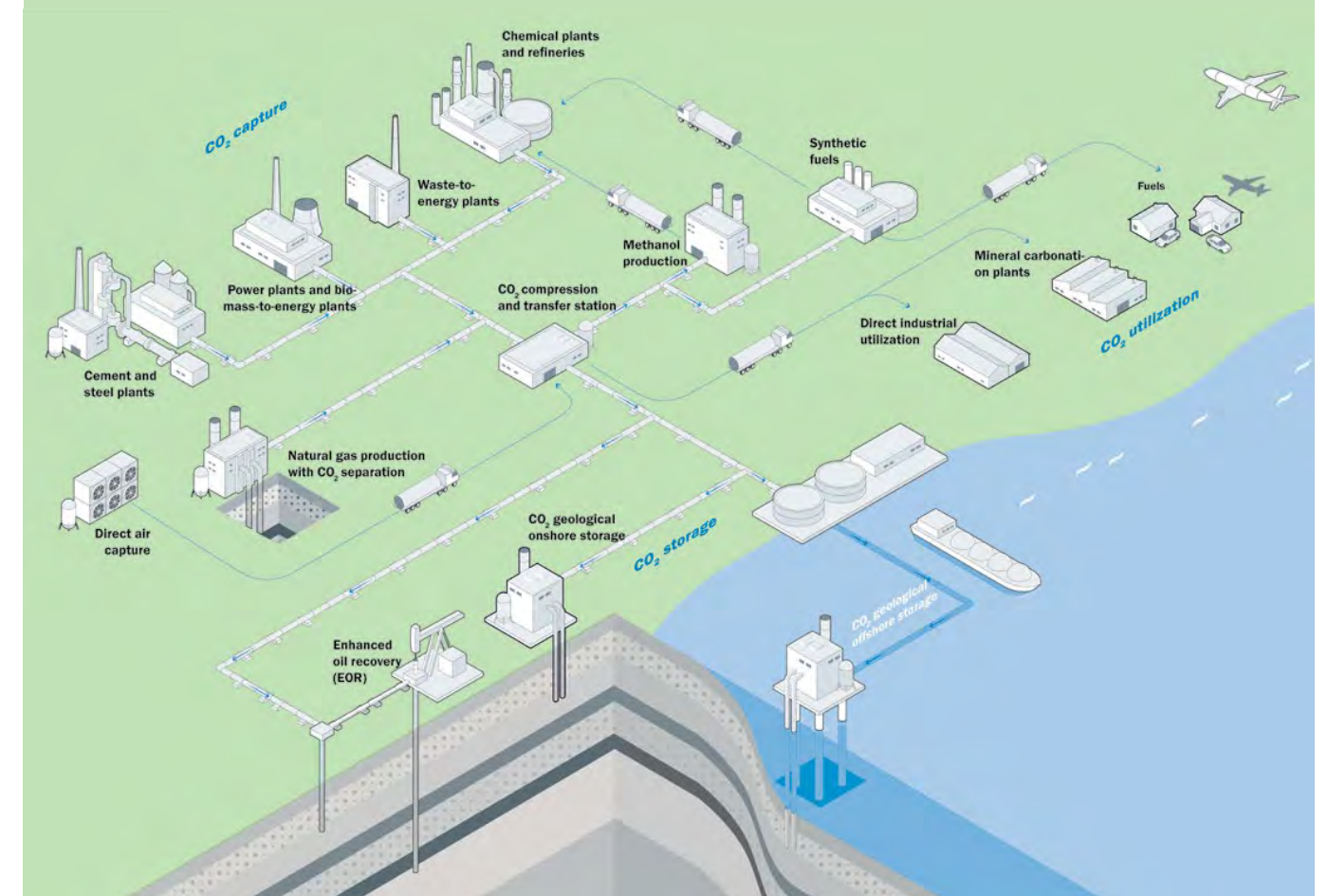

DESCRIPTION

Continuous gas analysers for quality measurement and reporting

Carbon capture processes produce a highly concentrated gas with more than 90% CO₂ by volume. On the other hand, there are the low carbon emissions to the environment, which have to be reported for taxation purposes. The gas mixtures contain other components that can be considered impurities, and which can be corrosive, and either have an influence on downstream process steps or are harmful to the environment.

To control and optimize the efficiency of processes and emissions along the CCUS value chain, SICK continuous gas analysers accurately measure the concentrations in CO₂ and other components in the gas mixture. Together with SICK's precise gas flow measurement, a true mass flow output is also available. Such measurements are essential prior to transportation, storage or utilization of CO₂.

Depending on the application, SICK can offer different measuring technologies, including:

- In-situ gas analysers accurately measuring CO₂ directly in the gas flow without gas sampling. The reliability, precision and short response time offer key advantages for efficient process control.
- Extractive analysers from SICK ensure continuous monitoring of multiple components simultaneously such as CO₂, H₂O, HCl, SO₂, CO, NO_x, NH₃ and O₂ with high accuracy to control and optimize the CCUS processes. The most suitable analyser can be selected depending on the application, the measuring conditions, and the requested measuring parameters.



Gas flow measurement for transfer and process applications

Carbon dioxide can be captured from different emission sources and then collected and transported via pipelines or ships for further handling steps such as storage or utilization. Gas flow measurements are necessary at each transfer point to control the quantity of captured CO₂ or the volume stored or transferred.

Accurate gas metering allows for precise accounting to companies or calculation of CO₂ taxes and credits based on regulations. With our experience in custody transfer applications for natural gas which can be easily transferred to CO₂ and our highly reliable ultrasonic gas flow meters, SICK provides the precise data required to operate the CCUS value chain. The FLOWSIC600/-XT gas flow meters deliver optimal measurement performance and provide the highest rated gas metering accuracy. Thanks to PowerIn Technology™, the FLOWSIC600-XT also ensures that measurements continue to be taken and data is stored even in the event of a power failure. The rugged design provides both the fault-free and maintenance free systems. Due to the direct path layout, the signals are not reflected inside the device and are thus not affected by contamination. This results in long-term system stability and accuracy.



Reliable turnkey solution for CO₂ metering

The FLOWSKID flow metering system is a full gas flow metering system. It is provided by SICK as a turnkey solution for transfer applications. The system is flexible in design and provides highly accurate measurement data. With FLOWSIC600 or FLOWSIC600-XT gas flow meters as the heart of the metering skid, system reliability can be assured. The metering skid can be customized with instrumentation including gas analysers, gas chromatographs, and supervisory computers – system solutions made by SICK! It is manufactured according to ISO standards and is of the highest quality in line with the latest DIN, ANSI, and ASME standards. This means the system will fulfil local regulations and requirements.



Space and protection for measurement and analysis technology

Container solutions are primarily used to protect the installed analyser systems from extreme ambient conditions such as heat, cold, dust, wind, earthquakes and corrosive or explosive atmospheres. They also offer advantages for transport as well as on-site installation and maintenance. At the factory, everything is coordinated and pre-installed in the container in a clear manner. Each container can be equipped to fit individual customer requirements. The installation of transformers and UPS, extinguishing, climate and gas warning systems is possible, as is the implementation of sample point switching or complex redundancy and signal concepts.





CONTACT

Email: ccus@slb.com
Web: www.ccus.slb.com

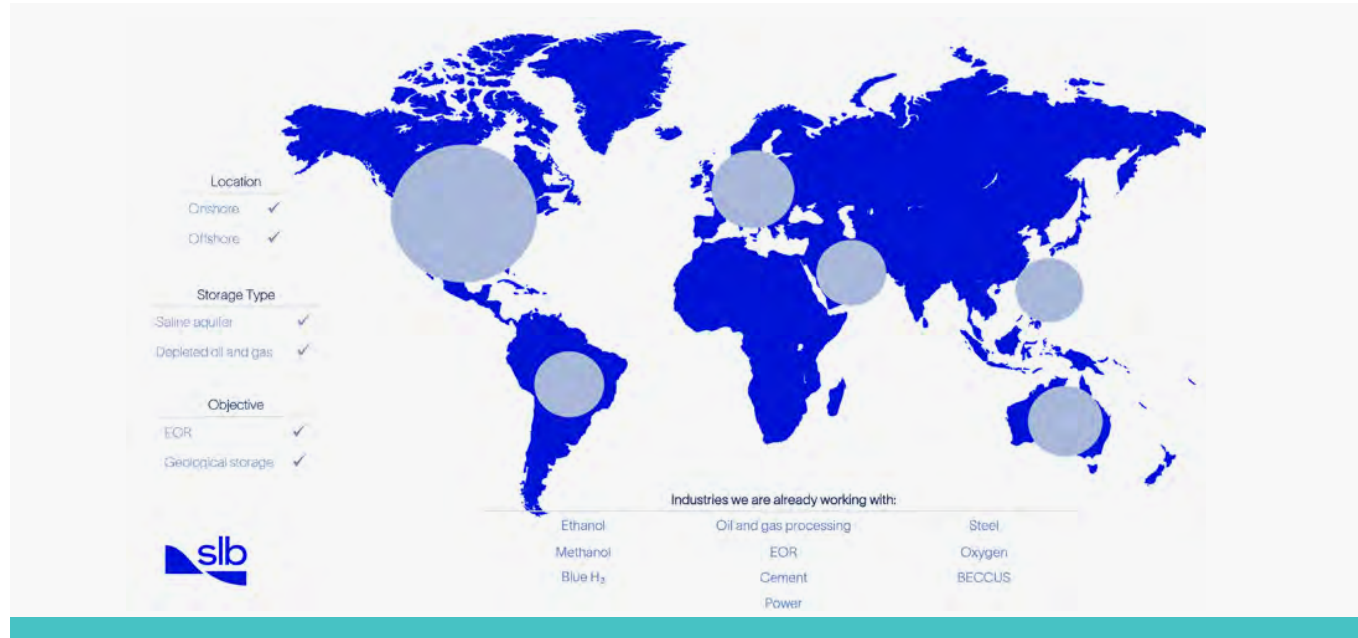

NAME OF TECHNOLOGY SERVICE PROVIDER

SLB

SUMMARY

Carbon capture and storage (CCS) is a critical component of advancing decarbonization and achieving the Paris Agreement's climate change goals. **As a technology leader in CCS and in the development of decarbonization and alternative energy solutions, SLB is actively progressing CCS technologies and business models to enable widespread adoption of CCS.**

What SLB brings to achieve these goals is more than 90 years of experience in characterizing and modelling underground rock formations and in designing and constructing wells. SLB's acquisition of Cameron in 2016 added a rich legacy in gas processing and pressure control equipment. For decades, we have been deploying digital tools and sophisticated sensors to improve operations, minimize risk, and monitor assets, including the use of automation, artificial intelligence, and comprehensive data management.

We applied this know-how to become an early technology leader in carbon capture for enhanced oil recovery (EOR) applications. Thirty-five years ago, we helped build the world's first commercial CO₂ plant at the SACROC Field in West Texas.

For over two decades, SLB has participated in more than 120 CCS projects around the globe, in different geological contexts and for various industry sectors. This hands-on experience, combined with our technology leadership, gives us unique insights into the varied complexities posed by CO₂ sequestration. In order to overcome these challenges, we have united the diverse disciplines of geoscience and engineering to develop innovative, integrated end-to-end processes that enable us to deliver sequestration projects anywhere in the world.

SLB has explored creating strategic partnerships with emitters to assess, develop, and operate projects spanning the entire CCS value chain, from capture to storage. The scope of collaboration goes beyond subsurface requirements and includes project economics, technology selection, business models, and permitting for a CCS project. By partnering with leaders in a range of strategic sectors, we are demonstrating viable and scalable CCS solutions across a wide range of industries. For example, we are *exploring with Lafarge Holcim* the feasibility of capturing carbon emissions from cement plants.

In addition to our deep expertise, technological leadership, and experience in creating viable CCS solutions, SLB is uniquely positioned to help scale up the manufacturing of CCS technologies. We are leveraging our more than 80 technology centres and extensive manufacturing capabilities around the world to industrialize and deploy CCS technologies globally.

SLB is developing, adapting, and applying innovative technologies in scalable business models to provide our customers and partners with economically viable solutions across the CCS value chain. In this "State of the Art: CCS Technologies 2023" report, we highlight some of the advanced technologies in our portfolio that significantly support the CCS industry today, organized into three sections:

- Capture, Gas Processing, and Transport
- Storage Selection, Design, and Construction
- Storage Monitoring, Verification, and Reporting.

CAPTURE, GAS PROCESSING, AND TRANSPORT

Highlighted Technologies and Services in our Portfolio

Capture and gas processing technologies

- Symmetry process software platform, available in our DELFI cognitive E&P environment
- CYNARA acid gas removal membrane system
- Amine gas treating systems
- SULFATREAT H₂S removal adsorbent
- Process Live data-enriched performance service

Transport technologies

- OLGA dynamic multiphase flow simulator, available in our DELFI environment
- Horizontal pumping systems for pressure boosting during transport
- Low-emission valves

Our Symmetry process software platform enables the design and simulation of CO₂ capture process workflows in one environment that integrates pipelines, capture and compression facilities, and safety models while ensuring consistent thermodynamics and fluid characterization across the full system. **The use of the Symmetry platform in several CCS projects in Canada was key in rightsizing the process design and accurately modelling the phase envelope and control system integration.** For each project, the Symmetry platform identified operational improvements and minimized health, safety, and environment (HSE) risks.

The choice of capture technology depends on the purity of the CO₂ stream and whether capture is pre-, post-, or oxy-combustion. Comprehensive evaluation of these options in the Symmetry platform can achieve the optimum system in terms of both technical and economic feasibility.

Once CO₂ is captured, a variety of treatment technologies may be needed. SLB offers both membrane systems and amine gas treatment systems in a range of designs and sizes to meet specific project requirements. The CYNARA acid gas removal membrane system works to separate CO₂ and H₂S from natural gas via preferential permeation of the smaller acid gas molecules. The separated CO₂ can be transported and sequestered at a selected storage site.

Monitoring valves and gas membrane systems with Process Live data-enriched performance service provides real-time status reports of performance and automates event detection. These insights mitigate the risk of downtime and reduce inventory costs. Using Process Live service, we currently are providing uptime assurance and treatment optimization of 4.92 Mtpa CO₂.

The OLGA dynamic multiphase flow simulator models and simulates the transportation of CO₂ from capture to injection. This enables a comprehensive understanding of optimal operating conditions to ensure that CO₂ remains in phase.

When transporting CO₂ between facilities, horizontal pumping systems provide the necessary pressure boost to maintain it in a fluid state. **SLB has more than 15 years of experience with a wide variety of CO₂ transport operations. We understand how the selection of appropriate seals, valves, production chemicals, and maintenance schedules plays a critical role in equipment longevity and operational safety.**

To date, SLB has installed thousands of industrial valves in various CO₂ and gas processing applications. In addition to enabling remote operation, these low-emission valves incorporate custom seals that reinforce their operational integrity. Some of the valves in this portfolio are manufactured to minimize leaks across the life of the valve.

To reduce maintenance downtime, our production chemistry technologies address specific problems of corrosion and hydrate formation.

STORAGE SELECTION, DESIGN, AND CONSTRUCTION

SLB has developed a wide range of risk assessment methods for screening geological formations and for identifying the most suitable site by conducting site characterization assessments. This in-depth assessment and evaluation of key criteria (such as storage capacity, injectivity, and containment) enables our customers to minimize cost while ensuring secure long-term CO₂ storage.



Integral to our involvement in CCS projects is our more than 35 years of petrotechnical software development experience paired with deep domain knowledge. End-to-end digital technologies harness this experience and expertise to drive workflows that screen, rank, design, model, simulate, and analyse every phase of the CCS project's life cycle.

By conducting the workflows within the DELFI cognitive exploration and production (E&P) environment, we leverage artificial intelligence and machine learning. For example, the interpretation workflows used to build a model of a storage site benefits from a 10x to 20x acceleration in workflow time by employing machine learning. Reservoir simulations benefit from high performance computing capabilities that reduce simulation time so that the engineers can focus on analysing results and exploring the full uncertainty space. **The DELFI environment was recently selected by the Northern Lights joint venture between Equinor, Shell, and TotalEnergies to streamline subsurface workflows and longer-term modelling and surveillance of CO₂ sequestration.**



Illustration of the Northern Lights CCS project (Courtesy of Equinor)

Once the storage site has been selected and the project commissioned, we leverage our decades of expertise in well construction to optimize construction operations, including the selection and installation of monitoring methods.

Well integrity has been identified as the biggest risk contributing to leakage of CO₂ from underground carbon storage sites. **EverCRETE CO₂-resistant cement system enables more efficient and secure underground storage compared with ordinary Portland cement.** Whereas ordinary Portland cement is not resistant to CO₂ fluids and can degrade in a few weeks or less, the reaction between CO₂ fluids and the EverCRETE system results in a stable structure after two weeks, and mechanical and chemical properties are no longer affected.

SLB designs and manufactures specialized wellheads, seals, and gate valves for achieving permanent underground sequestration of CO₂. Our corrosion-resistant equipment is constructed with a customized coating to withstand aggressive environments under any temperature conditions. The metal and elastomer seals used in these wellhead systems are proved to endure demanding pressures, temperatures, and corrosive environments.

STORAGE MONITORING, VERIFICATION, AND REPORTING

Securing CO₂ storage and containment over long periods of time requires properly monitoring the CO₂ plume and integrity of the wells. A cost-effective combination of sensors and monitoring protocols can deliver optimum performance control and risk management in compliance with regulatory requirements.

Monitoring strategy design must address

- what is to be monitored
- what are the property variations
- how will those variations occur

For a monitoring strategy to meet its objectives in terms of assurance, verification, and cost optimization, a holistic solution design and modelling workflow is required.

Critical to the success of the monitoring strategy design is the incorporation of dynamic geomechanical modelling, such as using our ECLIPSE, INTERSECT, and VISAGE simulators, for predicting subsurface behaviour and identifying the key parameters and their uncertainties. This informs the design and planning of appropriate geophysical measurements. **A successful monitoring strategy is able to history match the dynamic modelling against field observation to identify anomalies and update the subsurface model, monitoring strategy, and risk model accordingly in real time.**

Updating models requires timely measurements, for which a primary objective is to minimize data acquisition time and effort without adversely affecting interpretation quality. Our versatile and highly sensitive distributed fibre-optic sensing technology plays a significant role in achieving this balance by providing continuous data in both time and space. **Optiq fiber-optic solutions bring multidomain distributed sensing capabilities to CCS projects for significant efficiency improvements in time-lapse reservoir monitoring through permanent fibre installation or temporarily deployed fibre wireline cables.**

In a 2016 project with the US Department of Energy and Archer Daniels Midland Company (ADM), we installed modular intelligent completion equipment and Optiq solutions to enable real-time monitoring and control of the subsurface storage. Together, we captured from ADM's ethanol facility more than 2.5 Mt CO₂ over a period of three years.



ADM Overhead View

Highlighted Technologies and Services in our Portfolio

Site selection and design digital tools, available in our DELFI cognitive E&P environment

- OLGA dynamic multiphase flow simulator
- Petrel E&P software platform
- ECLIPSE industry reference reservoir simulator
- INTERSECT high-resolution reservoir simulator
- VISAGE finite-element geomechanics simulator
- Symmetry process software platform, available in our DELFI environment

Formation evaluation technologies

- Litho Scanner high-definition spectroscopy and laboratory services for X-ray diffraction, X-ray fluorescence, and Fourier transform infrared spectroscopy
- MR Scanner expert magnetic resonance and CMR-MagniPHI high-definition NMR service; triple-combo measurements for porosity, permeability, and capillary pressure; and laboratory services for routine and special core analysis, tight rock analysis, and mercury-injection capillary pressure measurement
- FMI-HD high-definition formation microimager, Quanta Geo photorealistic reservoir geology service, and laboratory services for whole core description, core fracture description, and goniometry
- Sonic Scanner acoustic scanning platform, MDT modular formation dynamics tester minifrac, XL-Rock large-volume rotary sidewall coring service, and laboratory services for unconfined compressive strength, triaxial stress testing, and pore volume compressibility
- MDT modular formation dynamics tester, Ora intelligent wireline formation testing platform, and laboratory services for water analysis
- PressureXpress reservoir pressure-while-logging service

- CoreFlow digital rock and fluid analytics services
- High-resolution well testing services

Well construction technologies

- DrillPlan coherent well construction planning solution
- EverCRETE CO₂-resistant cement system
- Wellhead equipment: compact wellheads, monoblock Christmas trees, coated FLS extreme-service API 6A slab-style gate valves, elastomer seals, metal-to-metal seals, MRD recessed-bore metal-to-metal seals

Well integrity technologies

- Wellbarrier well integrity life cycle solution
- Isolation Scanner cement evaluation service
- PS Platform production services platform multifinger imaging tool (PMIT)
- Slim cement mapping tool (SCMT)
- UCI ultrasonic casing imager, USI ultrasonic imager, and PowerEcho and PowerFlex annular barrier evaluation services
- EM Pipe Scanner electromagnetic casing inspection tool

Monitoring, verification and reporting technologies

- Optiq SLB fiber-optic solutions
- Pulsar multifunction pulsed neutron service and CHFR cased hole formation resistivity tool
- Optiq StreamLINE polymer-locked fiber-optic wireline conveyance
- Permanent gauges and pressure falloff (PFO) testing
- Isolation Scanner cement evaluation service and UCI ultrasonic casing imager

SLB as a Partner

Your company does not have to embark on its CCUS journey alone. SLB is a global technology company with the reach and resources to support your company's CCUS initiatives. Whether you require assistance evaluating the feasibility of your assets for carbon storage, services for CCUS well design, engineering and construction, or discrete CCUS technologies for your CCUS well construction, monitoring, measurement, or verification requirements, SLB has the technologies and services your CCUS project requires.

CHFR, CMR-MagniPHI, CoreFlow, CYNARA, DELFI, DrillPlan, ECLIPSE, EM Pipe Scanner, EverCRETE, FLS, FMI-HD, INTERSECT, Isolation Scanner, Litho Scanner, MDT, MRD, MR Scanner, OLGA, Optiq, Optiq Seismic, Optiq StreamLINE, Ora, Petrel, PowerEcho, PowerFlex, PressureXpress, Process Live, PS Platform, Pulsar, Quanta Geo, Sonic Scanner, Symmetry, SULFATREAT, UCI, USI, VISAGE, Wellbarrier, WellWatcher PS3, and XL-Rock are marks of SLB or a SLB company.

GET IN TOUCH

To find out more about the Global CCS Institute including Membership and our Consultancy services, visit globalccsinstitute.com or contact us.

AMERICAS

Washington DC, United States
americasoffice@globalccsinstitute.com

AUSTRALIA

Melbourne, Australia
info@globalccsinstitute.com

CHINA

Beijing, China
chinaoffice@globalccsinstitute.com

EUROPE

Brussels, Belgium
europeoffice@globalccsinstitute.com

JAPAN

Tokyo, Japan
japanoffice@globalccsinstitute.com

MIDDLE EAST AND NORTH AFRICA

Abu Dhabi, United Arab Emirates
menaregion@globalccsinstitute.com

UNITED KINGDOM

London, United Kingdom
ukoffice@globalccsinstitute.com

Copyright © 2023 Global CCS Institute

The Global CCS Institute has tried to make the information in this publication as accurate as possible. However, it does not guarantee that the information in this publication is totally reliable, accurate or complete. Therefore, the information in this publication should not be relied upon when making an investment or commercial decisions or provided to any third party without the written permission of the Global CCS Institute.

The Global CCS Institute has no responsibility for the persistence or accuracy of URLs to any external or third-party internet websites referred to in this publication and does not guarantee that any content on such websites is, or will remain, accurate or appropriate.

To the maximum extent permitted, the Global CCS Institute, its employees and advisers accept no liability (including for negligence) for any use or reliance on the information in this publication, including any commercial or investment decisions made on the basis of information provided in this publication.

The Global CCS Institute has relied on the contributions of over 60 CCS technology providers to compile this publication. Any claims regarding technology performance are the responsibility of the company concerned and are not endorsed by the Global CCS Institute. Readers should confirm any details contained in this Compendium with the technology holder concerned.