

Experiment 4: Open Channel Flow

Key Concepts: Flowrate Measurement, Weir Equations

Refer to: Roberson, Crowe & Elger, 7th ed., Chapter 13, pp. 607-611

I. Introduction

Determination of the flowrate of water in open channels is significant in many aspects of society. For example, urban and industrial water supplies must be measured so that demands are satisfied; the amount of water required for the dilution of pollutants being wasted into a river can be calculated mathematically, but metering devices are required to measure the supplied flow; and flood damage can be determined by correlating the depth of water passing over a dam spillway (a special type of weir) to the volume of water flowing downstream.

A **weir** is a vertical obstruction placed in an open channel, normal to the mean flow, thus forcing the flow over a crest designed to measure the flow rate. A well designed weir will exhibit subcritical flow upstream, accelerating to critical flow at the crest. For more information on subcritical and supercritical flow, refer to "Experiment 5: Hydraulic Jump" on page 39. This experiment will consider one class of weirs, known as *sharp-crested weirs*, which are smooth, vertical, flat plates with a sharpened upper edge. In particular, rectangular and triangular weirs will be studied.

Consider a schematic diagram of flow over a weir (Figure 12). Among the complicated features of the flow are:

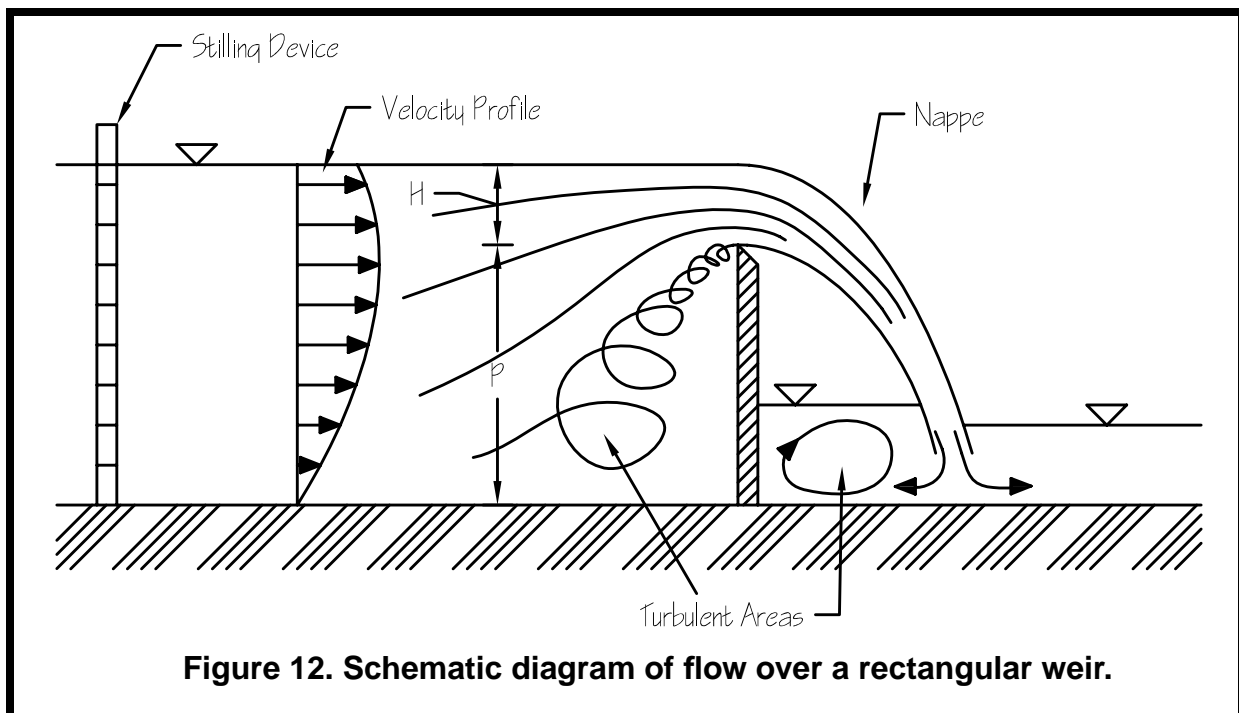

Figure 12. Schematic diagram of flow over a rectangular weir.

- (1) upstream velocity profile which varies over the vertical;
- (2) curved streamlines over the crest;
- (3) potentially inadequate ventilation under the nappe, which may result in subatmospheric pressure there;
- (4) secondary flows and other turbulent processes;
- (5) surface tension

For a first analysis, the problem is greatly simplified by neglecting these complicating features. A diagram of the simplified flow is shown in Figure 13.

Specifically, simplifications include:

- (1) uniform upstream velocity profile (generally valid for $H/P < 0.4$);
- (2) straight, horizontal streamlines over the crest;
- (3) good ventilation, and therefore atmospheric pressure, under the nappe;
- (4) neglect of secondary flows and other turbulent processes;
- (5) neglect of surface tension (generally valid for $H > 3\text{ cm}$).

Simplifications (2) and (3) indicate that the flow over the weir may be treated as a jet. Note that the velocity profile over the crest is still not uniform.

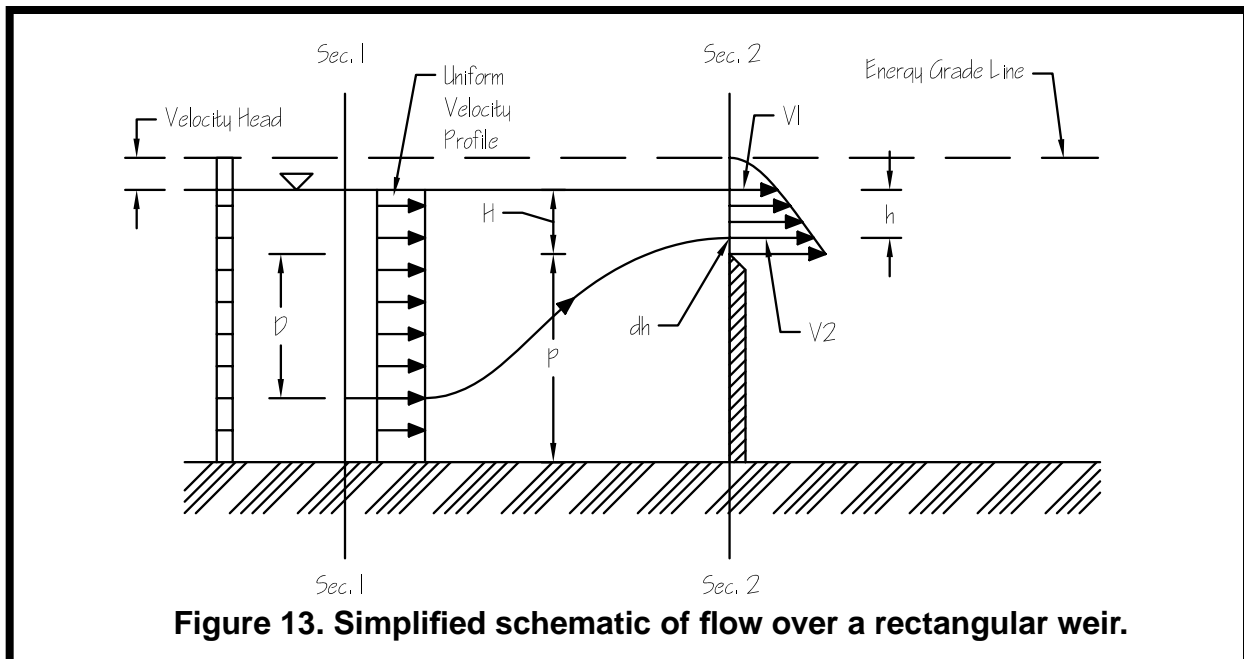

Figure 13. Simplified schematic of flow over a rectangular weir.

An expression for Q can now be derived. Because velocity over the crest is not uniform:

$$Q \neq VA \quad (1)$$

Rather, the more general expression for Q must be used:

$$Q = \int_0^H V dA \quad (2)$$

The velocity can be determined using Bernoulli's equation. Consider the Bernoulli equation between the two points on the streamline indicated in Figure 13:

$$\frac{p_1}{\gamma} + z_1 + \frac{V_1^2}{2g} = \frac{p_2}{\gamma} + z_2 + \frac{V_2^2}{2g} \quad (3)$$

Although the fluid is not ideal, viscosity may be neglected, for a first approximation, when the two points of interest are very close together, as they are here. For the simplified flow, $z_1 = 0$, $z_2 = H + D - h$, $p_1 = (H + D)\gamma$, and P_2 is zero gage. Algebraic manipulation yields an expression for V_2 in terms of V_1 , g and h :

$$V_2 = \sqrt{V_1^2 + 2gh} \quad (4)$$

If the upstream velocity is not only uniform, but also negligible, (4) becomes:

$$V_2 = \sqrt{2gh} \quad (5)$$

For the case of negligible upstream velocity, substitution of (5) into (2) yields:

$$Q = \int_0^H \sqrt{2gh} dA \quad (6)$$

Evaluation of the integral yields:

$$Q = \frac{2}{3} \sqrt{2g} LH^{3/2} \quad (7)$$

where L is the constant width of the weir. Letting $D = 2/3 \sqrt{2g}$ (a different D than above), (7) becomes:

$$Q = DLH^{3/2} \quad (8)$$

Unfortunately, (8) doesn't work particularly well when applied to natural flow situations. Fudge factors, C and n are therefore introduced:

$$Q = CLH^n \quad (9)$$

where C is a coefficient of discharge, which is not necessarily equal to D , but rather is a function of the geometry of the weir, and n is also a function of weir geometry. For weirs constructed to standard specifications, the values of C and n are constants for each weir design and are given below. *These values are only valid for the assumptions of the equation's derivation.* Be sure to use consistent units such as fps and feet or mps and meters.

Similarly, the formula for the V - notch weir is:

$$Q = CH^n \quad (10)$$

where C is a function of the notch angle, θ , and n is a constant. Refer to "Analysis of Log-Log Plots" on page 9 for the procedure to determine the values of n and C .

	Rectangular	90° V-notch
C	3.33 (fps) 1.84 (mps)	2.5 (fps) 1.38 (mps)
n	1.5	2.5

Table 2. Weir coefficients for standard, sharp-crested weirs

Note that if the upstream velocity is *not* negligible, the equation for a rectangular weir, analogous to (9), is:

$$Q = CL\left(H + \frac{V^2}{2g}\right)^{3/2} \quad (11)$$

The graphical method outlined above for the rectangular weir can be applied to a V-notch weir to determine C and n experimentally.

II. Objective

Develop weir calibration curves and determine the C and n values for two types of weirs. Determine the influence of the velocity head in this experiment. Determine the most

appropriate flow conditions for rectangular and V-notch weirs.

III. Anticipated Results

At a minimum, you should be able to anticipate:

- 1) Shape of Q vs. H curves (i.e. what is the relationship between Q and H ?).
- 2) Whether or not the velocity head is important or not.
- 3) Values of C and n for both types of weirs.
- 4) What flow characteristics are best for each type of weir (rectangular and V-notch)

IV. Apparatus

- 1) Reservoir-Channel apparatus with no channel slope, a volumetric flow meter, and a measuring deck.
- 2) Hook gage, stopwatch, scale, and protractor.
- 3) One rectangular and one triangular weir plate for the above apparatus.

V. Procedure

- 1) Check the reservoir water level. Open the drain in the tank basin.
- 2) Measure the upstream channel cross-section width.
- 3) Measure L or θ for one of the weir plates. Install the weir in the channel.
- 4) Position the hook gage next to the weir plate and zero the scale at the weir crest elevation. For the rectangular weir, measure the crest height from the channel bottom.
- 5) Determine a maximum flow rate by opening the flow control valve, and turning on the pump. The maximum flow rate will fill the flume tank and will not overflow the channel. For more accurate measurements, the water surface upstream of the weir should not be too turbulent. Insert the stopper to close the drain and observe the volumetric flow meter. Note that the meter is marked from zero to 40 liters. When the basin is empty, the level of the meter is below zero.
- 6) For the first measurement, use the maximum flowrate found in step 4. Obtain a steady flow through the channel and use the hook gage to determine the water surface elevation above the weir crest.
- 7) Close the drain. As the water fills the tank the volumetric flow meter will start to rise.
- 8) Use the stopwatch to record the time it takes to fill the tank to a given volume. Do not start timing until the volumetric flow rate meter has reached zero.
- 9) Compute and record the flowrate. Use the data collected in step 7.
- 10) Decrease the flow rate and repeat steps 5 through 8 for five different flow rates.
- 11) Repeat steps 2 through 9 for the other weir plate.

VI. Data Control

Data control consists of plotting Q vs. H (at log-log scale) for each weir. A linear relationship indicates good results.

VII. Results

- 1) Plot on a graph (at log-log scale) Q vs. H (use similar units such as cfs and feet) for each weir from: (a) the laboratory data, and (b) weir formula calculations - use your laboratory data for H and solve for Q using (9) and (10).
- 2) Plot Q vs. H on one log-log plot for only the rectangular suppressed weir using (a) the laboratory data, and (b) the laboratory data, with H increased by the addition of the velocity head. Use your laboratory H values, the width of the upstream cross-section, and the laboratory Q value to determine the upstream V (using $Q = VA$) and then calculate Q using (11).
- 3) Determine the C and n values of each weir using the laboratory data and the procedure outlined in the theory section. Compare to expected values.
- 4) What types of flows (e.g. high flow or low flow) are most appropriate for each type of weir shape?
- 5) Are the simplifying assumptions all valid? What effects might they have if not?

VIII. Suggested Data Sheet Headings ([] indicate the units of measurement)

Crest Length (L) _____ []

Notch Angle (θ) _____ []

Run #	Volume []	Time []	Discharge		Weir Type	Hook Gage []		
			[l/s]	[cfs]		W.S.	"0"	H