

HS29 SERIES UNITS

The HS29 is a residential split-system condensing unit. Condensing coil size, circuiting and air volume result in a minimum SEER rating of 10.0. The series is designed for use with an expansion valve or RFCIV system in the indoor unit. However, the HS29-651 and -060 use only the TXV system.

The HS29-141 and -012 utilizes a rotary compressor. Other HS29 units (-018, -024 and -211 through -653) utilize a reciprocating compressor. All compressors are hermetically sealed for trouble-free operation and long service life. Compressor components are spring-mounted within the sealed housing. The compressor is installed in the unit on resilient rubber mounts to assure quiet, vibration-free operation. A built-in protection device assures protection from excessive current and temperatures.

HS29-460 through HS29-650 models are furnished with crankcase heaters to assure proper compressor lubrication at all times. The heater is temperature-actuated and operates only when required. HS29-030 through -060 units utilize a scroll compressor. The scroll operates like a standard compressor but it is unique in the way it compresses refrigerant.

Several models are available in sizes ranging from 1 through 5 tons.

This manual is divided into sections which discuss the

major components, refrigerant system, charging procedure, maintenance and operation sequence.

All specifications in this manual are subject to change.

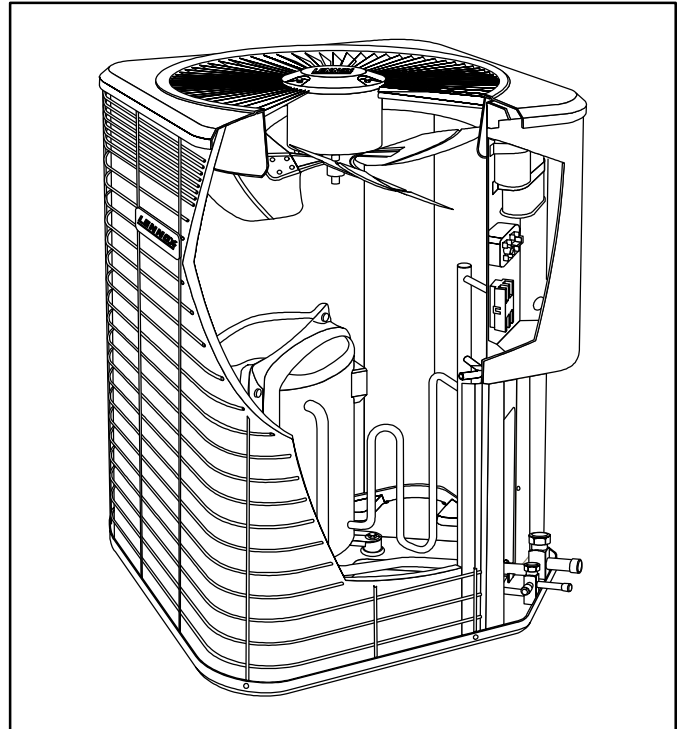

SPECIFICATIONS

Model No.		HS29-141	HS29-211	HS29-261	HS29-311	
Condenser Coil	Net face area - sq. ft. (m ²)	Outer coil	7.56 (0.70)	11.33 (1.05)	11.33 (1.05)	13.22 (1.23)
		Inner coil	----	----	----	----
	Tube diameter — in. (mm) & no. of rows		5/16 (7.9) — 1	5/16 (7.9) — 1	5/16 (7.9) — 1	5/16 (7.9) — 1
	Fins per inch (m)		22 (866)	22 (866)	22 (866)	22 (866)
Condenser Fan	Diameter — in. (mm) & no. of blades		18 (457) — 3	18 (457) — 3	18 (457) — 3	18 (457) — 3
	Motor hp (W)		1/6 (124)	1/6 (124)	1/6 (124)	1/6 (124)
	Cfm (L/s)		2400 (1135)	2400 (1135)	2400 (1135)	2460 (1160)
	Rpm		1105	1105	1105	1125
	Watts		180	180	180	170
*Refrigerant charge furnished (HCFC-22)		2 lbs. 12 oz. (1.25 kg)	3 lbs. 10 oz. (1.64 kg)	3 lbs. 13 oz. (1.73 kg)	4 lbs. 5 oz. (1.96 kg)	
Liquid line — in. (mm) o.d. connection (sweat)		†3/8 (9.5)	†3/8 (9.5)	†3/8 (9.5)	†3/8 (9.5)	
Suction line — in. (mm) o.d. connection (sweat)		5/8 (15.9)	5/8 (15.9)	5/8 (15.9)	3/4 (19.1)	
Shipping weight — lbs. (kg) 1 package		146 (66)	146 (66)	148 (67)	157 (71)	

*Refrigerant charge sufficient for 20 ft. (6.1 m) length of refrigerant lines.
 †3/8x5/16 in. (9.5x7.9mm) adaptor furnished for liquid line connection.

SPECIFICATIONS (contd.)

Model No.			HS29-411 HS29-413	HS29-461 HS29-463	HS29-511 HS29-513	HS29-651 HS29-653	HS29-681 HS29-683
Condenser Coil	Net face area - sq. ft. (m ²)	Outer coil	15.11 (1.40)	15.11 (1.40)	15.11 (1.40)	15.21 (1.41)	21.11 (1.96)
		Inner coil	----	5.40 (0.50)	5.44 (0.50)	14.0 (13.4)	20.3 (1.89)
	Tube diameter — in. (mm) & no. of rows		5/16 (7.9) — 1	5/16 (7.9) — 1.37	5/16 (7.9) — 1.37	5/16 (7.9) — 2	5/16 (7.9) — 2
	Fins per inch (m)		22 (866)	22 (866)	22 (866)	22 (866)	22 (866)
Condenser Fan	Diameter — in. (mm) & no. of blades		18 (457) — 4	18 (457) — 4	18 (457) — 4	18 (457) — 4	18 (457) — 4
	Motor hp (W)		1/6 (124)	1/6 (124)	1/3 (249)	1/3 (249)	1/3 (249)
	Cfm (L/s)		2520 (1190)	2500 (1180)	2950 (1390)	2930 (1385)	2930 (1385)
	Rpm		1100	1100	1100	1100	1100
	Watts		200	200	310	310	310
*Refrigerant charge furnished (HCFC-22)			5 lbs. 0 oz. (2.26 kg)	5 lbs. 9 oz. (2.52 kg)	6 lbs. 3 oz. (2.81 kg)	7 lbs. 10 oz. (3.46 kg)	12 lbs. 0 oz. (5.44 kg)
Liquid line — in. (mm) o.d. connection (sweat)			3/8 (9.5)	3/8 (9.5)	3/8 (9.5)	3/8 (9.5)	3/8 (9.5)
Suction line — in. (mm) o.d. connection (sweat)			3/4 (19.1)	7/8 (22.2)	7/8 (22.2)	1-1/8 (28.6)	1-1/8 (28.6)
Shipping weight — lbs. (kg) 1 package			165 (75)	191 (87)	196 (89)	212 (96)	254 (115)

*Refrigerant charge sufficient for 20 ft. (6.1 m) length of refrigerant lines.

SPECIFICATIONS (contd.)

Model No.			HS29-012	HS29-018	HS29-024	HS29-030
Condenser Coil	Net face area - sq. ft. (m ²)	Outer coil	7.56 (0.70)	11.33 (1.05)	11.33 (1.05)	13.22 (1.23)
		Inner coil	----	----	----	----
	Tube diameter — in. (mm) & no. of rows		5/16 (7.9) — 1	5/16 (7.9) — 1	5/16 (7.9) — 1	5/16 (7.9) — 1
	Fins per inch (m)		22 (866)	22 (866)	22 (866)	18 (748)
Condenser Fan	Diameter — in. (mm) & no. of blades		18 (457) — 3	18 (457) — 3	18 (457) — 3	18 (457) — 3
	Motor hp (W)		1/6 (124)	1/6 (124)	1/6 (124)	1/6 (124)
	Cfm (L/s)		2400 (1135)	2400 (1135)	2400 (1135)	2545 (1201)
	Rpm		1105	1105	1105	1110
	Watts		180	180	180	195
*Refrigerant charge furnished (HCFC-22)			2 lbs. 12 oz. (1.25 kg)	3 lbs. 10 oz. (1.64 kg)	3 lbs. 13 oz. (1.73 kg)	4 lbs. 4 oz. (1.93 kg)
Liquid line — in. (mm) o.d. connection (sweat)			†3/8 (9.5)	†3/8 (9.5)	†3/8 (9.5)	†3/8 (9.5)
Suction line — in. (mm) o.d. connection (sweat)			5/8 (15.9)	5/8 (15.9)	5/8 (15.9)	3/4 (19.1)
Shipping weight — lbs. (kg) 1 package			146 (66)	146 (66)	148 (67)	140 (64)

*Refrigerant charge sufficient for 20 ft. (6.0 m) length of refrigerant lines.
†3/8 x 5/16 in. (9.5 x 7.9 mm) adaptor furnished for liquid line connection.

SPECIFICATIONS (contd.)

Model No.			HS29-036	HS29-042	HS29-048	HS29-060
Condenser Coil	Net face area - sq. ft. (m ²)	Outer coil	15.11 (1.40)	15.11 (1.40)	15.11 (1.40)	15.11 (1.40)
		Inner coil	----	5.40 (0.50)	5.40 (0.50)	14.40 (1.34)
	Tube diameter — in. (mm) & no. of rows		5/16 (7.9) — 1	5/16 (7.9) — 1.37	5/16 (7.9) — 1.37	5/16 (7.9) — 2
	Fins per inch (m)		18 (748)			
Condenser Fan	Diameter — in. (mm) & no. of blades		18 (457) — 4	18 (457) — 4	18 (457) — 4	18 (457) — 4
	Motor hp (W)		1/6 (124)	1/6 (124)	1/3 (249)	1/3 (249)
	Cfm (L/s)		2545 (1201)	2610 (1232)	3115 (1470)	3010 (1420)
	Rpm		1100	1105	1125	1125
	Watts		210	200	325	315
*Refrigerant charge furnished (HCFC-22)			4 lbs. 9 oz. (2.07 kg)	5 lbs. 10 oz. (2.55 kg)	6 lbs. 1 oz. (2.75 kg)	8 lbs. 6 oz. (3.80 kg)
Liquid line — in. (mm) o.d. connection (sweat)			3/8 (9.5)	3/8 (9.5)	3/8 (9.5)	3/8 (9.5)
Suction line — in. (mm) o.d. connection (sweat)			3/4 (19.1)	7/8 (22.2)	7/8 (22.2)	1-1/8 (28.6)
Shipping weight — lbs. (kg) 1 package			145 (66)	158 (72)	191 (87)	207 (94)

*Refrigerant charge sufficient for 20 ft. (6.0 m) length of refrigerant lines.

ELECTRICAL DATA

Model No.		HS29-141	HS29-211	HS29-261	HS29-311	HS29-411	HS29-413	
Line voltage data — 60 hz		208/230v 1ph	208/230v 1ph	208/230v 1ph	208/230v 1ph	208/230v 1ph	208/230v 3ph	460v 3ph
Compressor	Rated load amps	4.9	8.6	10.1	11.8	17.5	10.3	4.3
	Power factor	.97	.97	.96	.92	.90	.83	.83
	Locked rotor amps	26.3	48.3	60.0	69.4	96.0	75.0	40.0
Condenser Coil Fan Motor	Full load amps	1.1	1.1	1.1	1.1	1.1	1.1	0.55
	Locked rotor amps	1.9	1.9	1.9	1.9	1.9	1.9	1.0
Rec. maximum fuse or circuit breaker size (amps)		15	15	20	25	40	20	10
*Minimum circuit ampacity		7.3	11.0	13.8	15.9	23.8	14.0	6.5

*Refer to National or Canadian Electrical Code manual to determine wire, fuse and disconnect size requirements.
NOTE — Extremes of operating range are plus 10% and minus 5% of line voltage.

ELECTRICAL DATA

Model No.		HS29-461	HS29-463		HS29-511	HS29-513		
Line voltage data — 60 hz		208/230v 1ph	208/230v 3ph	460v 3ph	208/230v 1ph	208/230v 3ph	460v 3ph	575v 3ph
Compressor	Rated load amps	17.5	12.8	6.4	23.4	14.0	7.1	5.8
	Power factor	.98	.93	.93	.98	.88	.88	.88
	Locked rotor amps	92.0	87.0	44.0	110.0	91.0	46.0	37.0
Condenser Coil Fan Motor	Full load amps	1.1	1.1	0.55	1.9	1.9	0.90	0.90
	Locked rotor amps	1.9	1.9	1.0	4.1	4.1	2.1	2.1
Rec. maximum fuse or circuit breaker size (amps)		40	25	15	50	30	15	10
*Minimum circuit ampacity		23.0	17.1	8.6	31.2	19.4	9.8	8.2

*Refer to National or Canadian Electrical Code manual to determine wire, fuse and disconnect size requirements.
NOTE — Extremes of operating range are plus 10% and minus 5% of line voltage.

ELECTRICAL DATA

Model No.		HS29-651	HS29-653			HS29-681	HS29-683	
Line voltage data — 60 hz		208/230v 1ph	208/230v 3ph	460v 3ph	575v 3ph	208/230v 1ph	208/230v 3ph	460v 3ph
Compressor	Rated load amps	26.9	17.3	9.0	7.1	27.1	18.6	7.9
	Power factor	.98	.86	.86	.86	.97	.86	.86
	Locked rotor amps	123.0	128.0	64.0	51.0	175.0	128.0	63.0
Condenser Coil Fan Motor	Full load amps	1.9	1.9	0.90	0.90	1.9	1.9	0.90
	Locked rotor amps	4.1	4.1	2.1	2.1	4.1	2.1	2.1
Rec. maximum fuse or circuit breaker size (amps)		60	40	20	15	60	40	15
*Minimum circuit ampacity		35.5	23.5	12.2	9.8	35.8	24.2	10.8

*Refer to National or Canadian Electrical Code manual to determine wire, fuse and disconnect size requirements.
NOTE — Extremes of operating range are plus 10% and minus 5% of line voltage.

ELECTRICAL DATA

Model No.		HS29-012	HS29-018	HS29-024	HS29-030	HS29-036
Line voltage data — 60 hz		208/230v 1ph	208/230v 1ph	208/230v 1ph	208/230v 1ph	208/230v 1ph
Compressor	Rated load amps	4.9	7.9	10.1	14.7	16.0
	Power factor	.97	.97	.96	.90	.91
	Locked rotor amps	26.3	48.3	60.0	84.0	100.0
Condenser Coil Fan Motor	Full load amps	1.1	1.1	1.1	1.1	1.1
	Locked rotor amps	1.9	1.9	1.9	1.9	1.9
Rec. maximum fuse or circuit breaker size (amps)		15	15	20	30	35
*Minimum circuit ampacity		7.3	11.0	13.7	19.5	21.1

*Refer to National or Canadian Electrical Code manual to determine wire, fuse and disconnect size requirements.
NOTE — Extremes of operating range are plus 10% and minus 5% of line voltage.

ELECTRICAL DATA

Model No.		HS29-042	HS29-048	HS29-060
Line voltage data — 60 hz		208/230v 1ph	208/230v 1ph	208/230v 1ph
Compressor	Rated load amps	18.6	23.7	28.8
	Power factor	.84	.98	.95
	Locked rotor amps	127.0	129.0	169.0
Condenser Coil Fan Motor	Full load amps	1.1	1.9	1.9
	Locked rotor amps	1.9	4.1	4.1
Rec. maximum fuse or circuit breaker size (amps)		40	50	60
*Minimum circuit ampacity		24.4	31.5	37.9

*Refer to National or Canadian Electrical Code manual to determine wire, fuse and disconnect size requirements.
NOTE — Extremes of operating range are plus 10% and minus 5% of line voltage.

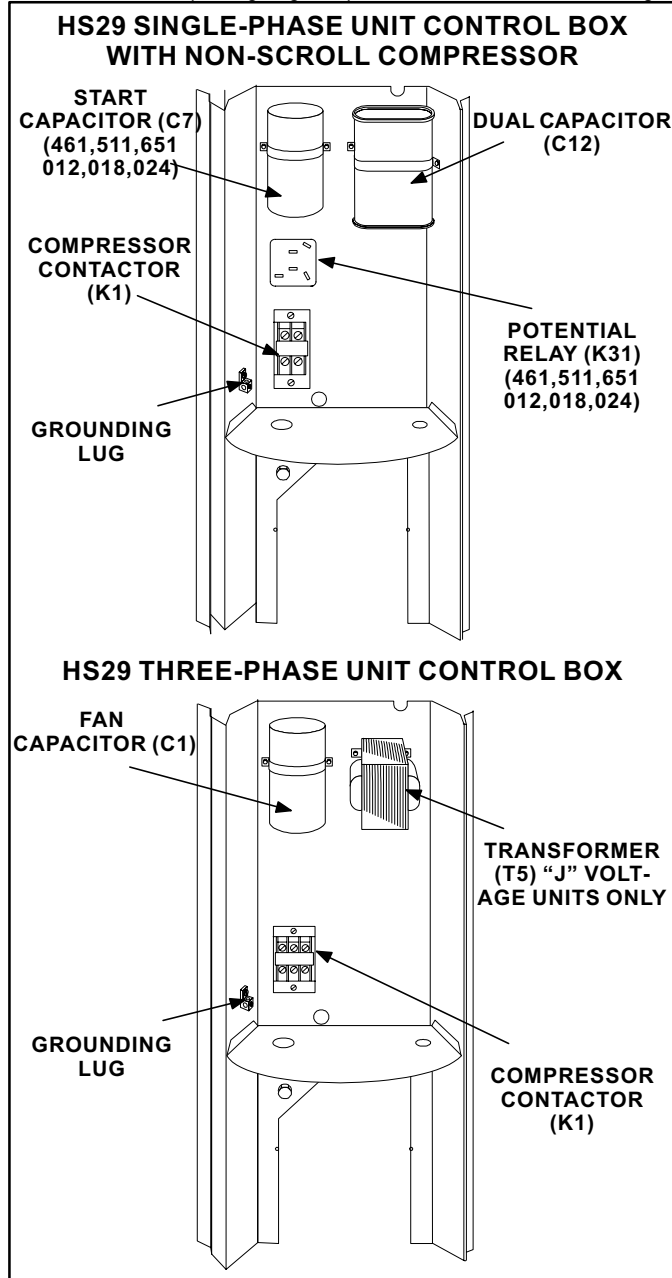

FIGURE 1

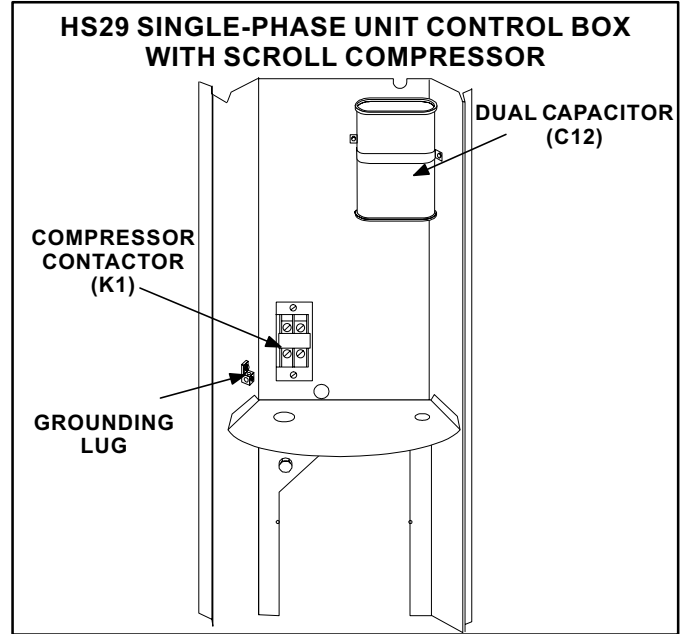
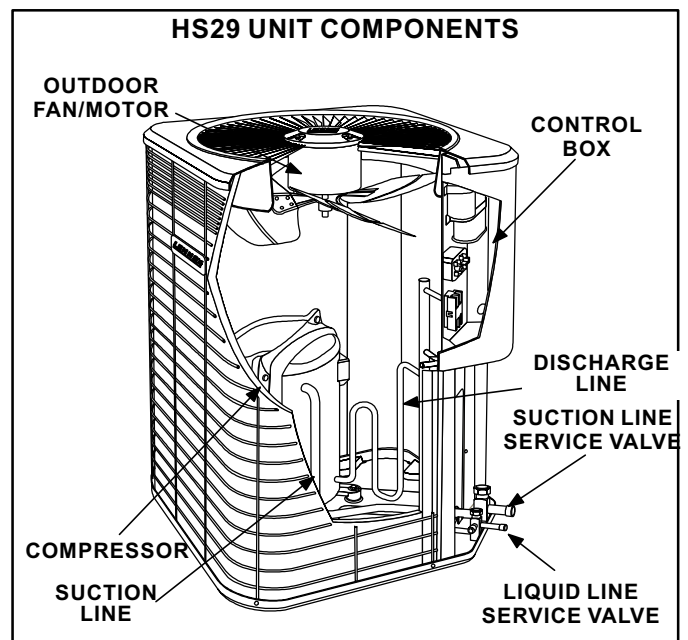

FIGURE 2



FIGURE

I - UNIT INFORMATION

HS29 condensing units are available in 1, 1 -1/2, 2, 2 -1/2, 3, 3 -1/2, 4 and 5 ton capacities.

All major components (indoor blower/coil) must be matched according to Lennox recommendations for the compressor to be covered under warranty. Refer to the Engineering Handbook for approved system matchups. A misapplied system will cause erratic operation and can result in early compressor failure.

II - UNIT COMPONENTS

Unit components are illustrated in figure 2.

A - Control Box (Figure 1 and Figure 2)

Electrical openings are provided under the control box cover. Field thermostat wiring is made to color-coded pigtail connections.

1 - Compressor Contactor K1

The compressor is energized by a contactor located in the control box. See figure 1 and figure 2. Two-pole contactors are used in single-phase units and three-pole contactors are used in three-phase units. K1 is energized by the indoor thermostat terminal Y1 (24V) when thermostat demand is present.

HS29 units are not equipped with a 24V transformer. All 24 VAC controls are powered by the indoor unit. Refer to wiring diagram.

2 - Dual Capacitor C12

The compressor (scroll, rotary or reciprocating) and fan in single-phase units use permanent split capacitor motors. The capacitor is located inside the unit control box (see figure 1 and figure 2). A single "dual" capacitor (C12) is used for both the fan motor and the compressor (see unit wiring diagram). The fan side and the compressor side of the capacitor have different MFD ratings. See table 1 for dual capacitor ratings.

3 - Transformer T5

Transformer T5 is used on all "J" voltage units. T5 is used as a step-down transformer for the outdoor fan motor. The transformer is located inside the unit control box (see figure 1). The transformer is rated at 3.4 VA with a 575 volt primary and a 460 volt secondary.

TABLE 1

HS29 Dual Capacitor Rating (C12)			
HS29 Unit	Terminal	MFD	VAC
141-1, 012	FAN	5	370
	HERM	25	
261-1, 261-2 024	FAN	5	
	HERM	30	
211-1, 211-2 311-1, 311-2, 030, 018	FAN	5	370
	HERM	35	
311-3, 411-3	FAN	5	370
	HERM	45	
411-1, 411-2	FAN	5	370
	HERM	50	
-511	FAN	7.5	370
	HERM	50	
-048, -681	FAN	7.5	370
	HERM	60	
-060	FAN	7.5	
	HERM	80	
-651	FAN	7.5	370
	HERM	70	
-036, -042	FAN	5	440
	HERM	40	

4 - Start Capacitor C7

All HS29-461, 511, 651, 012, 018 and 024 units use a start capacitor (C7) wired in parallel with the compressor side of the dual capacitor. The capacitor is located inside the unit control box (see figure 1). C7 is switched off by potential relay (K31) when the compressor nears full speed. See table 2 for Start capacitor ratings.

TABLE 2

HS29 Start Capacitor Ratings (C7)		
Unit	VAC	MFD
-461, -511, -651	320	176-216
-012	330	88-108
-018, -024	330	145-175

5 - Fan Capacitor C1

The fans in three-phase HS29-413, -463, -513, -653, -683, units use permanent split capacitor motors. A single capacitor C1 is used for the fan motor. The capacitor is located inside the unit control box (see figure 1). Table 3 shows the ratings of C1.

TABLE 3

HS29 FAN CAPACITOR RATING (C1)		
HS29 Unit	MFD	VAC
-413, -463,	5	370
-653, -683, -060	7.5	370

6 - Potential (Start) Relay K31

All HS29-461,511,651,012,018 and 024 series units use a potential relay which controls the operation of the starting circuit. The potential relay is located inside the unit control box (see figure 1). The relay is normally closed when contactor K1 is de-energized. When K1 energizes, the compressor immediately begins start-up. K31 remains closed during compressor start-up and the start capacitor C7 remains in the circuit. When the compressor reaches 75% of its speed, K31 is energized. When K31 energizes, the contacts open and the start capacitor C7 is taken out of the circuit.

B - Compressor

(Rotary, Reciprocating and Scroll)

HS29-141 and -012 units utilize a rotary compressor. HS29-018, -024, and -211 through -653 units utilize a conventional reciprocating compressor. Table 4 shows the specifications for reciprocating and rotary compressors used in HS29 units.

HS29-030 through -060 units utilize a scroll compressor. The scroll compressor design is simple, efficient and requires few moving parts. A cutaway diagram of the scroll compressor is shown in figure 4. The scrolls are located in the top of the compressor can and the motor is located just below. The oil level is immediately below the motor.

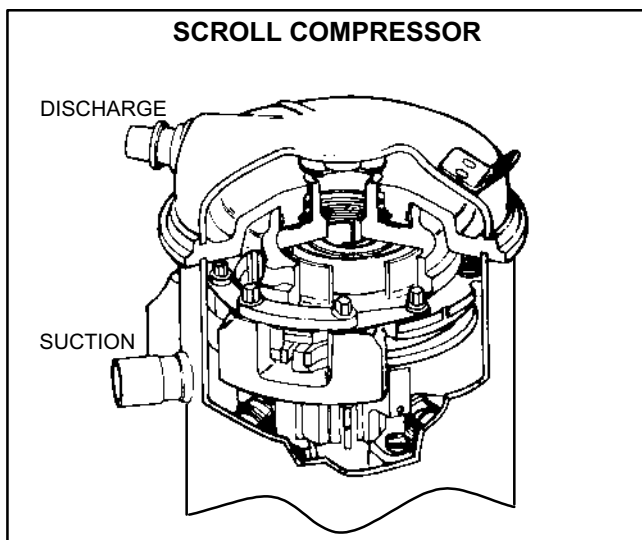

FIGURE 4

The scroll is a simple compression concept centered around the unique spiral shape of the scroll and its inherent properties. Two identical scrolls are mated together forming concentric spiral shapes. One scroll remains stationary, while the other is allowed to "orbit." The orbiting scroll does not rotate or turn but merely orbits the stationary scroll. Due to its efficiency, the scroll compressor is capable of drawing a much deeper vacuum than reciprocating compressors. Deep vacuum operation can cause internal fusite arcing resulting in damaged internal parts and will result in compressor failure. Never use a scroll compressor for evacuating or for deep vacuum operation (operating compressor at 0 psig or lower) on the system. Table 5 shows the specifications of scroll compressors used in the HP29 series units.

TABLE 4

HS29 COMPRESSOR SPECIFICATIONS					
Unit	Man/Model	Vac/PH	LRA	RLA	Oil fl. oz.
012	TEC/RK5512E	208/230 1	26.3	4.9	14
018	TEC/AW5516EXD	208/230 1	48.3	7.9	32
024	TEC/AW5522EXD	208/230 1	60	10.1	32
141	TEC/RK5512E	208/230 1	26.3	4.9	14
211-1	COP/CR16K6-PFV	208/230 1	49	8.6	45
211-2	TEC/AW300ET	208/230 1	48.3	12.4	32
261-1,-2	COP/CR22K6-PFV	208/230 1	56	9.8	45
261-3	TEC/AW302ET	208/230 1	60.0	8.9	32
311-1,-2	COP/CR28K6-PFV	208/230 1	75	13.7	45
311-3	TEC/AW304ET	208/230 1	69.4	11.8	32
411-1,-2	COP/CR34K6-PFV	208/230 1	96	16.2	45
411,3	TEC/AVD5535	208/230 1	92	13.8	54
413-1,-2	COP/CR35K6-TF5	208/230 3	75	10.3	45
413-3	TEC/AV126RT	208/230 3	75	8.8	54
413-1,-2	COP/CR35K6-TFD	460 3	40	4.3	45
413-3	TEC/AV126TT	460 3	37.5	4.4	54
461	TEC/AV5540F	208/230 1	92	17.5	54
463	TEC/AV14ORT	208/230 3	84	11.4	54
463	TEC/AV140TT	460 3	42	8	54
511	TEC/AV5545F	208/230 1	110	23.4	54
513	TEC/AV5545F	208/230 3	91	14	54
513	TEC/AV5545F	460 3	46	7.1	54
513	TEC/AV5545F	575 3	37	5.8	54
651	TEC/AV5558F	208/230 1	123	26.9	54
653	TEC/AV5558F	208/230 3	128	17.3	54
653	TEC/AV5558F	460 3	64	9	54
653	TEC/AV5558F	575 3	51	7.1	54
681	COP/ZR61KC	208/230 1	175	27.1	
683	COP/ZR61KC-TF5	208/230 3	128	18.6	72
683	COP/ZR61KC-TFD	460 3	63.0	7.9	72

Three-Phase Compressor Rotation

Three-phase scroll compressors must be phased sequentially to ensure correct compressor rotation and operation. At compressor start-up, a rise in discharge and drop in suction pressures indicates proper compressor phasing and operation. If discharge and suction pressures do not perform normally, follow the steps below to correctly phase the unit.

- 1 - Disconnect power to the unit.
- 2 - Reverse any two field power leads to the unit. (Prefer L1 and L3).
- 3 - Reapply power to the unit.

Discharge and suction pressures should operate within their normal start-up ranges.

NOTE - Compressor noise level may be significantly higher when phasing is incorrect and the unit will not provide cooling when compressor is operating backwards. Continued backward operation will cause the compressor to cycle on internal protector.

TABLE 5

HS29 COMPRESSOR SPECIFICATIONS					
Unit	Man/Model	Vac/PH	LRA	RLA	Oil fl. oz.
-030	COP/ZR30KC-PFV	208/230 1	84	14.7	42
-036	COP/ZR36KC-PFV	208/230 1	100	16	42
-042	COP/ZR42KC-PFV	208/230 1	127	18.6	42
-048	COP/ZR49K3-PFV	208/230 1	129	23.7	66
-060	COP/ZR61K3-PFV	208/230 1	169	28.8	56

1 - Crankcase Heater

A crankcase heater is used on all HS29-460 through HS29-650 models and an option on all others. Some heaters will be insertion-type and self-regulating while others will be the band type. The heater is temperature-actuated and operates only when required.

2 - Compressor Cover (Figure 5)

A compressor cover constructed of vinyl-faced fiberglass is an option on all HS29 units. The cover provides an acoustic barrier. The cover slides over the compressor and is held secure with snap buttons. Slits are provided for installation around the discharge and suction lines.

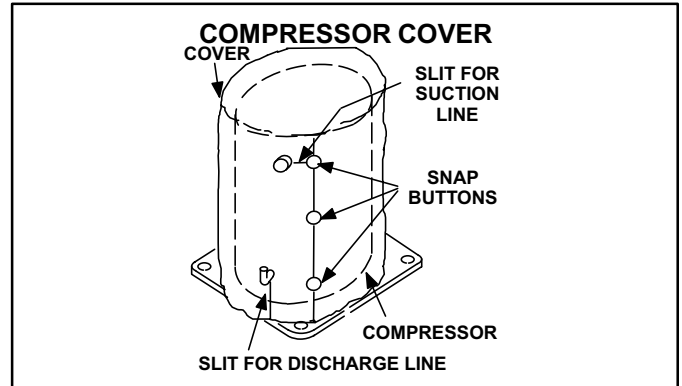

FIGURE 5

C - Condenser Fan Motor

All units use single-phase PSC fan motors which require a run capacitor. In all units, the condenser fan is controlled by the compressor contactor.

ELECTRICAL DATA tables in this manual show specifications for condenser fans used in HS29s.

Access to the condenser fan motor on all units is gained by removing the seven screws securing the fan assembly. See figure 6. The condenser fan motor is removed from the fan guard by removing the four nuts found on the top panel.

⚠ DANGER

Make sure all power is disconnected before beginning electrical service procedures.

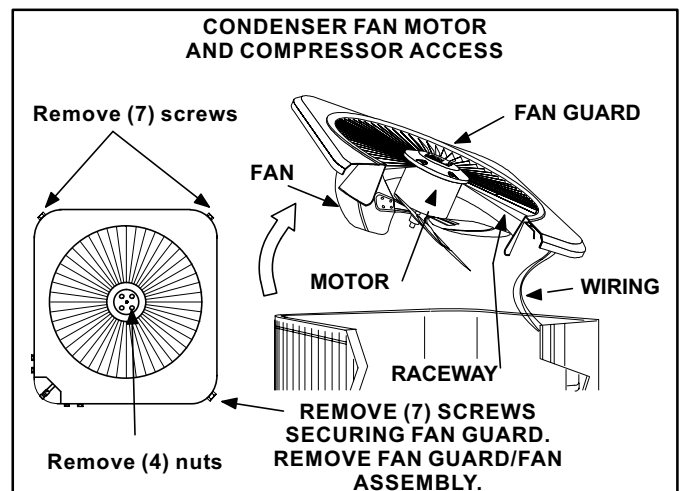

FIGURE 6

III - REFRIGERANT SYSTEM

A - Plumbing

Field refrigerant piping consists of liquid and suction lines from the condensing unit (sweat connections) to the indoor evaporator coil (flare or sweat connections). Use Lennox L10 (flare) or L15 (sweat, non-flare) series line sets as shown in table 6 or table 7 or use field-fabricated refrigerant lines.

Separate discharge and suction service ports are provided outside the unit for connection of gauge manifold during charging procedure.

TABLE 6

Condensing Unit Model No.	Line Set Model No. (L10 or L15)	Length of Lines		Liquid Line Outside Dia.		Suction Line Outside Dia.	
		ft.	m	in.	mm	in.	mm
HS29-141 HS29-211 HS29-261	L10/15-21-20	20	6	5/16	7.9	5/8	15.9
	L10/15-21-25	25	8				
	L10/15-21-35	35	11				
	L10/15-21-50	50	15				
HS29-311	L15-31-20	20	6	5/16	7.9	3/4	19
	L15-31-30	30	9				
	L15-31-40	40	12				
	L15-31-50	50	15				
HS29-410	L10/15-41-20	20	6	3/8	9.5	3/4	19
	L10/15-41-30	30	9				
	L10/15-41-40	40	12				
	L10/15-41-50	50	15				
HS29-460 HS29-510	L10/15-65-30	30	9	3/8	9.5	7/8	22.2
	L10/15-65-40	40	12				
	L10/15-65-50	50	15				
HS29-651 HS29-681	*Field fabricate		3/8	9.5	1-1/8	28.5	

*Field fabricate.

TABLE 7

Condensing Unit Model No.	Line Set Model No. (L10 or L15)	Length of Lines		Liquid Line Outside Dia.		Suction Line Outside Dia.	
		ft.	m	in.	mm	in.	mm
HS29-012 HS29-018 HS29-24	L15-21-20	20	6	5/16	7.9	5/8	15.9
	L15-21-25	25	8				
	L15-21-35	35	11				
	L15-21-50	50	15				
HS29-030	L15-31-20	20	6	5/16	7.9	3/4	19
	L15-31-30	30	9				
	L15-31-40	40	12				
	L15-31-50	50	15				
HS29-036	L15-41-20	20	6	3/8	9.5	3/4	19
	L15-41-30	30	9				
	L15-41-40	40	12				
	L15-41-50	50	15				
HS29-042 HS29-048	L15-65-30	30	9	3/8	9.5	7/8	22.2
	L15-65-40	40	12				
	L15-65-50	50	15				
HS29-060	*Field fabricate		3/8	9.5	1-1/8	28.5	

*Field fabricate.

B - Service Valves

The liquid and suction line service valves (figures 7 and 8) and gauge ports are accessible from outside the unit.

The valve is equipped with a service port. The service ports are used for leak testing, evacuating, charging and checking charge. A schrader valve is factory installed. A service port cap is supplied to protect the schrader valve from contamination and serve as the primary leak seal.

NOTE-Always keep valve stem caps clean.

To Access Schrader Port:

- 1 - Remove service port cap with an adjustable wrench.
- 2 - Connect gauge to the service port.
- 3 - When testing is completed, replace service port cap. Tighten finger tight, then an additional 1/6 turn.

To Open Liquid or Suction Line Service Valve:

- 1 - Remove stem cap with an adjustable wrench.
- 2 - Using service wrench and 5/16" hex head extension back the stem out counterclockwise until the valve stem just touches the retaining ring.
- 3 - Replace stem cap tighten firmly. Tighten finger tight, then tighten an additional 1/6 turn.

DANGER

Do not attempt to backseat the service valves past the retaining ring. Attempts to backseat the service valves past the retaining ring will cause snap ring to explode from valve body under pressure of refrigerant. Personal injury and unit damage will result.

To Close Liquid or Suction Line Service Valve:

- 1 - Remove stem cap with an adjustable wrench.
- 2 - Using service wrench and 5/16" hex head extension, turn stem clockwise to seat the valve. Tighten firmly.
- 3 - Replace stem cap. Tighten finger tight, then tighten an additional 1/6 turn.

Suction Line (Ball Type) Service Valve (5 Ton Only)

A ball-type full service valve is used on HS29 5 ton units. These suction line service valves function the same way, differences are in construction. Valves are not rebuildable. If a valve has failed it must be replaced. A ball valve is illustrated in figure 9.

The ball valve is equipped with a service port. A schrader valve is factory installed. A service port cap is supplied to protect the schrader valve from contamination and assure a leak free seal.

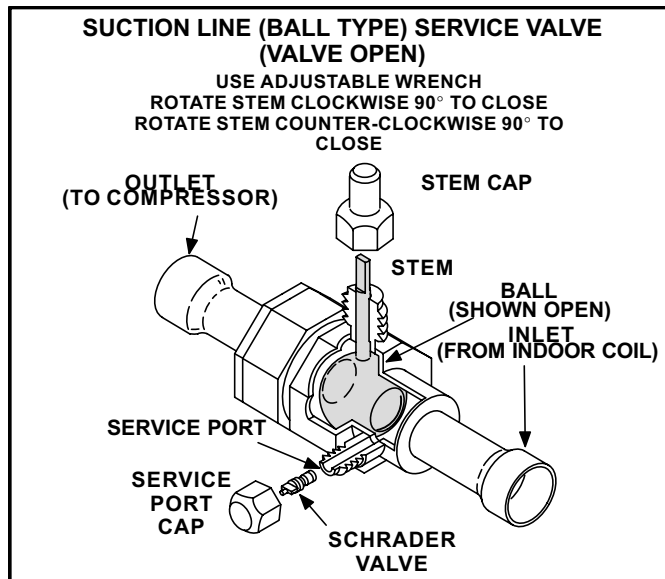
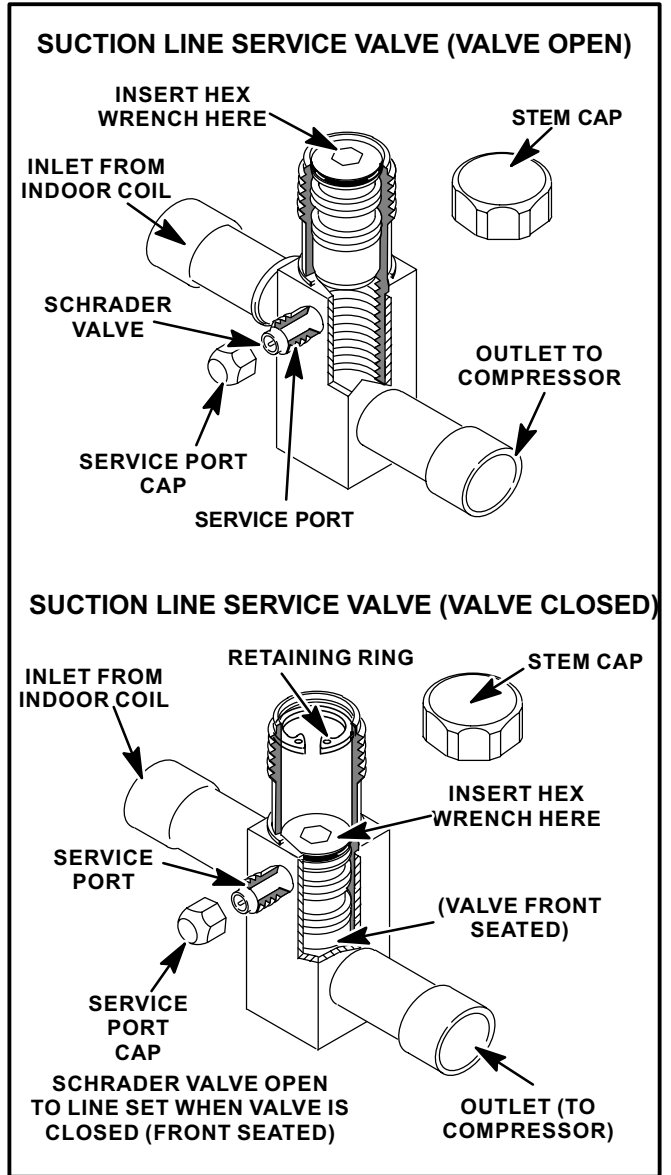
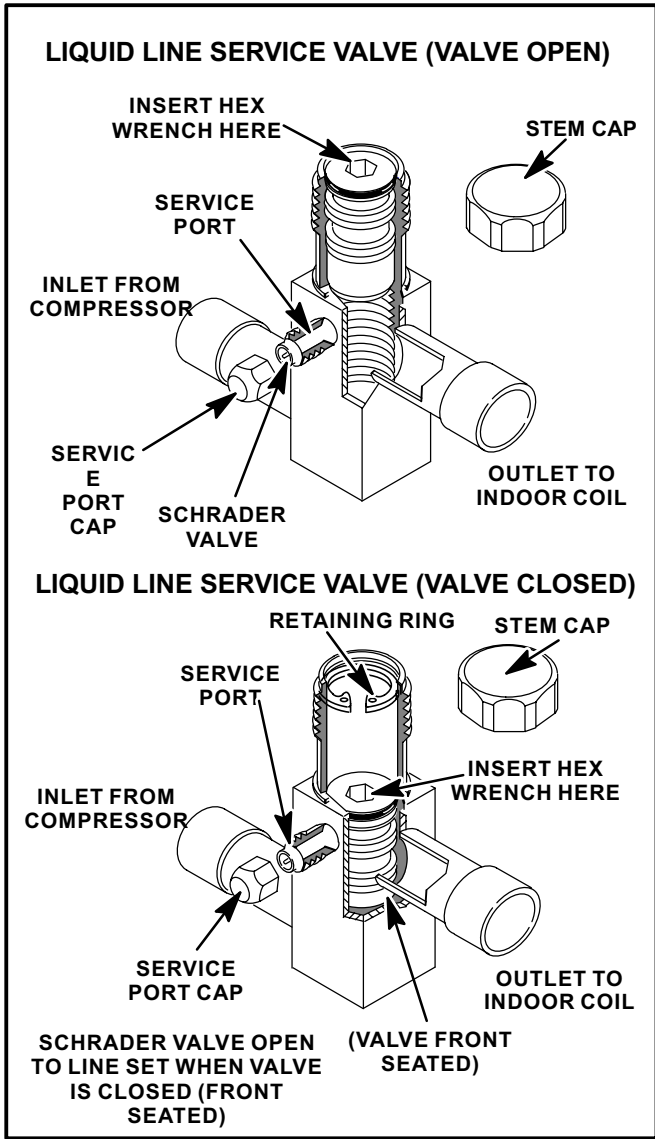

IV - CHARGING

The unit is factory-charged with the amount of HCFC-22 refrigerant indicated on the unit rating plate. This charge is based on a matching indoor coil and outdoor coil with a 20 foot (6.1 m) line set. For varying lengths of line set, refer to table 8 for refrigerant charge adjustment. A blank space is provided on the unit rating plate to list actual field charge.

TABLE 8

LIQUID LINE SET DIAMETER	Ounce per 5 ft. (ml per mm) adjust line set*
1/4 in. (6mm)	1 ounce per 5 ft. (30 ml per 1524 mm)
5/16 in. (8mm)	2 ounce per 5ft. (60 ml per 1524 mm)
3/8 in. (10 mm)	3 ounce per 5 ft. (90 ml per 1524 mm)

**If line set is greater than 20 ft. (6.1 m) add this amount. If line set is less than 20 ft. (6.1 m) subtract this amount.*

Units are designed for line sets up to 50 ft (15.2 m). Consult Lennox Refrigerant Piping Manual for line sets over 50 ft (15.2 m).

! IMPORTANT

If line length is greater than 20 feet (6.1 m) add this amount. If line length is less than 20 feet (6.1 m), subtract this amount.

A - Pumping Down System

! CAUTION

Vacuum operation (operating compressor at 0 psig or lower) can cause internal fusite arcing resulting in a damaged or failed compressor. This type of damage will result in denial of warranty claim.

The system may be pumped down when leak checking the line set and indoor coil or making repairs to the line set or indoor coil.

- 1- Attach gauge manifold.
- 2- Front seat (close) liquid line valve.
- 3- Start outdoor unit.
- 4- Monitor suction gauge. Stop unit when 0 psig is reached.
- 5- Front seat (close) suction line valve.

B - Leak Testing (To Be Done Before Evacuating)

- 1- Attach gauge manifold and connect a drum of dry nitrogen to center port of gauge manifold.
- 2- Open high pressure valve on gauge manifold and pressurize line set and indoor coil to 150 psig (1034 kPa).
- 3- Check lines and connections for leaks.

NOTE-If electronic leak or Halide detector is used, add a small amount of HCFC-22 (3 to 5 psig (20kPa to 34kPa)) then pressurize with nitrogen to 150 psig.

- 4- Release nitrogen pressure from the system, correct any leaks and recheck.

! CAUTION

When using dry nitrogen, a pressure reducing regulator must be used to prevent excessive pressure in gauge manifold, connecting hoses, and within the system. Regulator setting must not exceed 150 psig (1034 kpa). Failure to use a regulator can cause equipment failure resulting in injury.

C - Evacuating the System

- 1- Attach gauge manifold. Connect vacuum pump (with vacuum gauge) to center port of gauge manifold. With both manifold service valves open, start pump and evacuate indoor coil and refrigerant lines.

! IMPORTANT

A temperature vacuum gauge, mercury vacuum (U-tube), or thermocouple gauge should be used. The usual Bourdon tube gauges are not accurate enough in the vacuum range.

! IMPORTANT

The compressor should never be used to evacuate a refrigeration or air conditioning system.

- 2- Evacuate the system to 29 inches (737mm) vacuum. During the early stages of evacuation, it is desirable to stop the vacuum pump at least once to determine if there is a rapid loss of vacuum. A rapid loss of vacuum would indicate a leak in the system and a repeat of the leak testing section would be necessary.
- 3- After system has been evacuated to 29 inches (737mm), close gauge manifold valves to center port, stop vacuum pump and disconnect from gauge manifold. Attach an upright nitrogen drum to center port of gauge manifold and open drum valve slightly to purge line at manifold. Break vacuum in system with nitrogen pressure by opening manifold high pressure valve. Close manifold high pressure valve to center port.
- 4- Close nitrogen drum valve and disconnect from gauge manifold center port. Release nitrogen pressure from system.
- 5- Connect vacuum pump to gauge manifold center port. Evacuate system through manifold service valves until vacuum in system does not rise above .5mm of mercury absolute pressure or 500 microns within a 20-minute period after stopping vacuum pump.
- 6- After evacuation is complete, close manifold center port, and connect refrigerant drum. Pressurize system slightly with refrigerant to break vacuum.

D - Charging

If the system is completely void of refrigerant, the recommended and most accurate method of charging is to weigh the refrigerant into the unit according to the total amount shown on the unit nameplate. Also refer to the SPECIFICATIONS tables on pages 1 and 2.

If weighing facilities are not available or if unit is just low on charge, the following procedure applies.

1 - Expansion Valve Systems

The following procedures are intended as a general guide for use with expansion valve systems only. For best results, indoor temperature should be between 70°F and 80°F (21.1°C and 26.7°C). Outdoor temperature should be 60°F (15.6°C) or above. Slight variations in charging temperature and pressure should be expected. Large variations may indicate need for further servicing.

⚠ IMPORTANT

The following procedure requires accurate readings of ambient (outdoor) temperature, liquid temperature and liquid pressure for proper charging. Use a thermometer with accuracy of $\pm 2^\circ\text{F}$ ($\pm 1.1^\circ\text{C}$) and a pressure gauge with accuracy of ± 5 PSIG (± 34.5 kPa).

APPROACH METHOD (TXV SYSTEMS)

(Ambient Temperature of 60°F [16°C] or Above)

NOTE- It may be necessary to restrict air flow in order to reach liquid pressures in the 200-250 psig range which are required for checking charge. The indoor temperature should be above 70°F (21°C). Block equal sections of air intake panels as shown in figure 10, moving obstructions sideways until liquid pressures in the 200-250 psig range are reached.

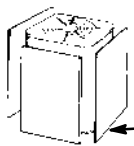

BLOCKING OUTDOOR COIL
Block outdoor coil one side at a time with cardboard or plastic sheets until proper testing pressures are reached.

CARDBOARD OR PLASTIC SHEET

FIGURE 10

- 1- Connect gauge manifold. Connect an upright HCFC-22 drum to center port of gauge manifold.
- 2- Record outdoor air (ambient) temperature.
- 3- Operate indoor and outdoor units in cooling mode. Allow outdoor unit to run until system pressures stabilize.

- 4 - Make sure thermometer well is filled with mineral oil before checking liquid line temperature.
- 5 - Place thermometer in well and read liquid line temperature. Liquid line temperature should be warmer than the outdoor air temperature. Table shows how many degrees warmer the liquid line temperature should be.

Add refrigerant to lower the liquid line temperature.

Recover refrigerant to raise the liquid line temperature.

Add refrigerant slowly as the unit approaches the correct temperature. This will allow refrigerant to stabilize allowing the correct temperature to be read.

TABLE 9

HS29 MODEL NO.	Approach Temperature Liquid Line - Outdoor Ambient °F (°C)
-141, -012	7 (3.6)
-211, -018	4 (2.2)
-261, -024	5 (2.8)
-311	10 (5.6)
-410, -460	12 (6.7)
-036	14 (7.8)
-510, -650, -048	13 (7.2)
-030	11 (6.1)
-036	14 (7.8)
-042	17 (9.5)
-060	12 (6.7)

- 6 - When unit is properly charged, liquid line pressures should approximate those in table 10.

⚠ IMPORTANT

Use tables 10 and 11 as a general guide for performing maintenance checks. Tables 10 and 11 are not a procedure for charging the system. Minor variations in these pressures may be expected due to differences in installations. Significant deviations could mean that the system is not properly charged or that a problem exists with some component in the system. Used prudently, tables 10 and 11 could serve as a useful service guide.

2 - RFCIV Systems

The following procedures are intended as a general guide for use with RFCIV systems only. For best results, indoor temperature should be between 70°F and 80°F (21.1°C and 26.7°C). Outdoor temperature should be 60°F (15.6°C) or above. Slight variations in charging temperature and pressure should be expected. Large variations may indicate a need for further servicing.

- 1 - Connect gauge manifold. Connect an upright HCFC-22 drum to center port of gauge manifold.
- 2 - Operate indoor and outdoor units. Allow outdoor unit to run until system pressures stabilize.
- 3 - Make sure thermometer well is filled with mineral oil before checking liquid line temperature.
- 4 - Read liquid line pressure and convert to condensing temperature using temperature/ pressure conversion chart.
Condensing temperature (read from gauges) should be warmer than liquid line temperature.
- 5 - Place thermometer in well and read liquid line temperature. Table 12 and table 13 show how much warmer the condensing temperature should be.
- 6 - Subtract liquid line temperature from condensing temperature to determine subcooling. Compare with table 10.
Add refrigerant to lower liquid line temperature.
Recover refrigerant to raise liquid line temp.
- 7 - When unit is properly charged liquid line pressures should approximate table 10 .

E - Oil Charge

Refer to table 4 on page 6 and table 5 on page 7.

V - MAINTENANCE

At the beginning of each heating or cooling season, the system should be cleaned as follows:

A - Outdoor Unit

- 1 - Clean and inspect condenser coil. (Coil may be flushed with a water hose).
- 2 - Visually inspect all connecting lines, joints and coils for evidence of oil leaks.

B - Indoor Coil

- 1 - Clean coil if necessary.
- 2 - Check connecting lines and coil for evidence of oil leaks.
- 3 - Check condensate line and clean if necessary.

C - Indoor Unit

- 1 - Clean or change filters.
- 2 - Bearings are pre-lubricated and need no further oiling.
- 3 - Check all wiring for loose connections.
- 4 - Check for correct voltage at unit.
- 5 - Check amp-draw on blower motor.
Unit nameplate _____ Actual _____.

TABLE 10

NORMAL OPERATING PRESSURES*																
OUTDOOR ENTERING AIR TEMPERATURE °F (°C)	HS29-141		HS29-211		HS29-261		HS29-311		HS29-411		HS29-461		HS29-511		HS29-651	
	LIQ. ±10 PSIG	SUC. ±10 PSIG	LIQ. ±10 PSIG	SUC. ±10 PSIG	LIQ. ±10 PSIG	SUC. ±10 PSIG	LIQ. ±10 PSIG	SUC. ±10 PSIG	LIQ. ±10 PSIG	SUC. ±10 PSIG	LIQ. ±10 PSIG	SUC. ±10 PSIG	LIQ. ±10 PSIG	SUC. ±10 PSIG	LIQ. ±10 PSIG	SUC. ±10 PSIG
65 (18.3) (RFCIV)	-	-	155	65	160	65	168	63	176	62	174	64	181	65	-	-
75 (24) (RFCIV)	-	-	181	70	188	70	197	68	203	66	205	69	208	70	-	-
85 (29.4) (RFCIV)	-	-	208	75	216	74	227	73	233	70	236	73	239	75	-	-
95 (35) (RFCIV)	-	-	238	80	247	78	258	77	266	74	271	77	271	79	-	-
105 (40.6) (RFCIV)	-	-	270	84	280	82	292	80	299	77	305	80	306	82	-	-
65 (18.3) (TXV)	150	70	159	73	164	71	173	71	179	68	180	71	187	73	150	70
75 (24) (TXV)	179	71	183	75	189	73	199	73	205	70	208	73	212	75	179	71
85 (29.4) (TXV)	211	73	209	77	217	75	228	75	235	72	238	75	241	77	211	73
95 (31.2) (TXV)	269	76	238	80	247	78	258	77	266	74	271	77	271	79	269	76
105 (40.6) (TXV)	286	75	269	82	279	80	292	79	299	77	305	79	305	80	286	75

* These are typical pressures only. Indoor evaporator match up, indoor air quantity and evaporator load will cause the pressures to vary.

TABLE 11

NORMAL OPERATING PRESSURES*

OUTDOOR ENTERING AIR TEMPERATURE °F (°C)	HS29-012		HS29-018		HS29-024		HS29-030		HS29-036		HS29-042		HS29-048		HS29-060	
	LIQ. +10 PSIG	SUC. +10 PSIG	LIQ. +10 PSIG	SUC. +10 PSIG	LIQ. +10 PSIG	SUC. +10 PSIG	LIQ. +10 PSIG	SUC. +10 PSIG	LIQ. +10 PSIG	SUC. +10 PSIG	LIQ. +10 PSIG	SUC. +10 PSIG	LIQ. +10 PSIG	SUC. +10 PSIG	LIQ. +10 PSIG	SUC. +10 PSIG
65 (18.3) (RFCIV)	145	71	155	65	160	65	160	64	165	62	166	67	163	66	-	-
75 (24) (RFCIV)	167	77	181	70	188	70	185	67	192	66	194	70	190	69	-	-
85 (29.4) (RFCIV)	192	81	208	75	216	74	216	71	223	69	223	72	221	72	-	-
95 (35) (RFCIV)	221	84	238	80	247	78	248	73	257	71	257	75	254	74	-	-
105 (40.6) (RFCIV)	253	87	270	84	280	82	284	76	292	73	291	76	289	77	-	-
65 (18.3) (TXV)	140	79	159	73	164	71	154	68	162	66	156	70	152	70	151	69
75 (24) (TXV)	161	80	183	75	189	73	174	70	190	67	184	71	180	71	179	71
85 (29.4) (TXV)	189	81	209	77	217	75	204	70	224	68	214	72	210	72	211	73
95 (31.2) (TXV)	220	83	238	80	247	78	246	72	257	71	261	74	255	74	249	74
105 (40.6) (TXV)	254	84	269	82	279	80	276	74	296	72	291	75	288	75	286	75

* These are typical pressures only. Indoor evaporator match up, indoor air quantity and evaporator load will cause the pressures to vary.

**TABLE 12
SUBCOOLING FOR RFC SYSTEMS**

OUTDOOR TEMP. °F (°C)	LIQUID SUBCOOLING [± 1°F (.6°C)]						
	-141	-211	-261	-311	-411	-461	-511
60 (16)	14 (7.8)	17 (9.5)	18 (10)	18 (10)	14 (7.8)	16 (8.9)	15 (8.3)
65 (18)	13 (7.2)	16 (8.9)	16 (8.9)	17 (9.5)	13 (7.2)	15 (8.3)	14 (7.8)
70 (21)	12 (6.7)	15 (8.3)	14 (7.8)	16 (8.09)	12 (6.7)	14 (7.8)	13 (7.2)
75 (24)	10 (5.6)	14 (7.8)	12 (6.7)	15 (8.3)	10 (5.6)	13 (7.2)	11 (6.1)
80 (27)	9 (5)	13 (7.2)	11 (6.1)	14 (7.8)	9 (5)	12 (6.7)	10 (5.6)
85 (29)	8 (4.5)	12 (6.7)	10 (5.6)	13 (7.2)	8 (4.5)	11 (6.1)	8 (4.5)
90 (32)	7 (3.9)	11 (6.1)	9 (5)	12 (6.7)	7 (3.9)	10 (5.6)	7 (3.9)
95 (35)	6 (3.3)	9 (5)	8 (4.5)	11 (6.1)	6 (3.3)	9 (5)	7 (3.9)
100 (38)	4 (2.2)	8 (4.5)	7 (3.9)	10 (5.6)	5 (2.8)	8 (4.5)	6 (3.3)
105 (41)	2 (1.1)	7 (3.9)	6 (3.3)	9 (5)	4 (2.2)	6 (3.3)	4 (2.2)
110 (43)	2 (1.1)	6 (3.3)	6 (3.3)	7 (3.9)	3 (1.7)	5 (2.8)	3 (1.7)
115 (45)	1 (0.6)	5 (2.8)	5 (2.8)	5 (2.8)	2 (1.1)	3 (1.7)	2 (1.1)

**TABLE 13
SUBCOOLING FOR RFC SYSTEMS**

OUTDOOR TEMP. °F (°C)	LIQUID SUBCOOLING [± 1°F (.6°C)]						
	-012	-018	-024	-030	-036	-042	-048
60 (16)	14 (7.8)	17 (9.5)	18 (10)	14 (7.8)	13 (7.2)	12 (6.7)	11 (6.1)
65 (18)	13 (7.2)	16 (8.9)	16 (8.9)	14 (7.8)	13 (7.2)	11 (6.1)	10 (5.6)
70 (21)	12 (6.7)	15 (8.3)	14 (7.8)	13 (7.2)	12 (6.7)	11 (6.1)	10 (5.6)
75 (24)	10 (5.6)	14 (7.8)	12 (6.7)	13 (7.2)	12 (6.7)	10 (5.6)	9 (5)
80 (27)	9 (5)	13 (7.2)	11 (6.1)	13 (7.2)	12 (6.7)	10 (5.6)	9 (5)
85 (29)	8 (4.5)	12 (6.7)	10 (5.6)	13 (7.2)	11 (6.1)	10 (5.6)	9 (5)
90 (32)	7 (3.9)	11 (6.1)	9 (5)	13 (7.2)	11 (6.1)	9 (5)	8 (4.5)
95 (35)	6 (3.3)	9 (5)	8 (4.5)	12 (6.7)	11 (6.1)	9 (5)	7 (3.9)
100 (38)	4 (2.2)	8 (4.5)	7 (3.9)	12 (6.7)	10 (5.6)	8 (4.5)	7 (3.9)
105 (41)	2 (1.1)	7 (3.9)	6 (3.3)	11 (6.1)	10 (5.6)	7 (3.9)	6 (3.3)
110 (43)	2 (1.1)	6 (3.3)	6 (3.3)	11 (6.1)	9 (5)	6 (3.3)	5 (2.8)
115 (45)	1 (0.6)	5 (2.8)	5 (2.8)	10 (5.6)	9 (5)	5 (2.8)	4 (2.2)

VI - WIRING DIAGRAMS AND SEQUENCE OF OPERATION

HS29 SINGLE-PHASE OPERATING SEQUENCE (RECIPROCATING OR ROTARY COMPRESSOR)

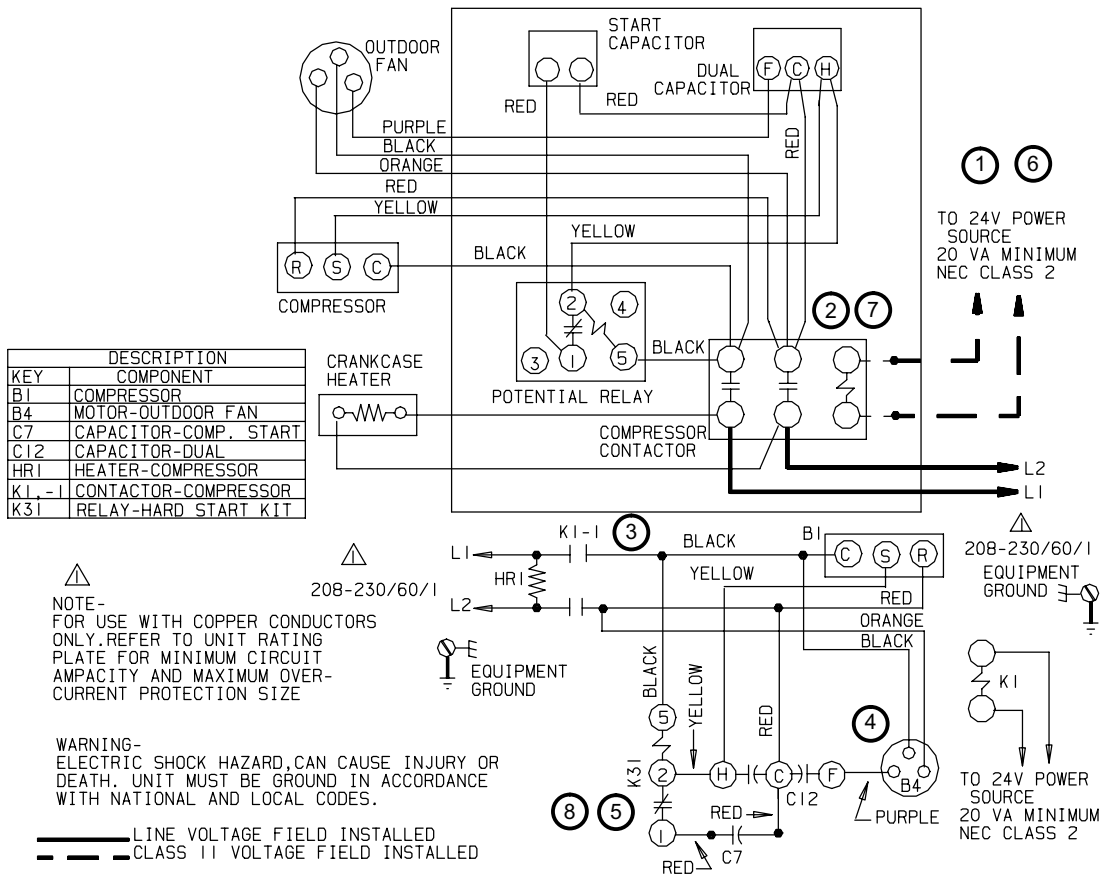

A-HS29 "P" Voltage Operation Sequence

This is the sequence of operation for HS29-461/511/651 and HS29-012/018/024 "P" voltage units. The HS29-141/211/261/311/411/681 "P" voltage units are similar; however, these units are not equipped with the hard start kit. The sequence is outlined by numbered steps which correspond to circled numbers on the adjacent diagram.

NOTE- The thermostat used may be electromechanical or electronic.

NOTE- Transformer in indoor unit supplies power (24 VAC) to the thermostat and outdoor unit controls.

COOLING:

- 1 - Cooling demand initiates at Y1 in the thermostat.
- 2 - 24VAC from indoor unit energizes compressor contactor K1.
- 3 - K1-1 N.O. closes, energizing terminal "C" of compressor (B1) and outdoor fan motor (B4).
- 4 - Outdoor fan motor (B4) begins immediate operation.
- 5 - Compressor (B1) begins start-up. Hard start contactor K31 remains closed during start-up and start capacitor C7 remains in the circuit. As the compressor gains speed, K31 is energized. When K31 is energized, the contacts open and start capacitor C7 is taken out of the circuit.

END OF COOLING DEMAND:

- 6 - Cooling demand is satisfied. Terminal Y1 is de-energized.
- 7 - Compressor contactor K1 is de-energized.
- 8 - K1-1 opens and compressor (B1) and outdoor fan motor (B4) are de-energized and stop immediately.

HS29 THREE-PHASE OPERATING SEQUENCE

(ALL COMPRESSORS)

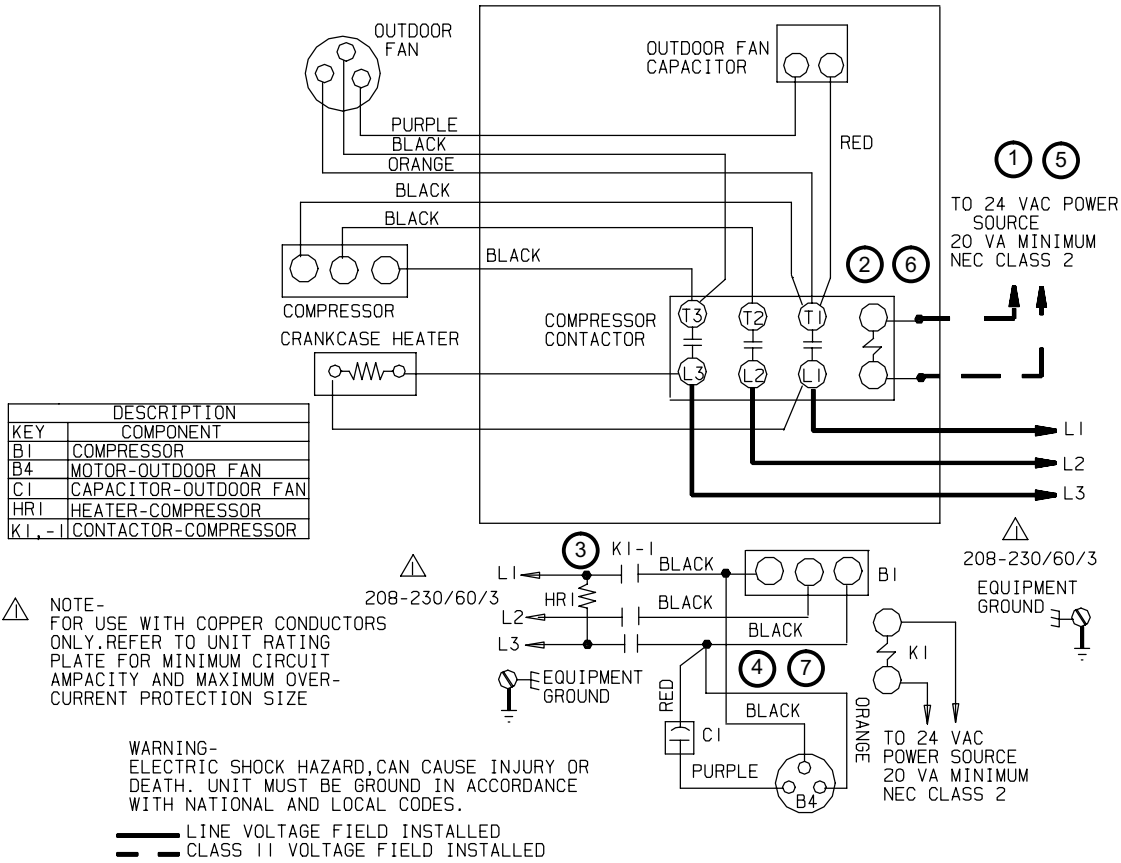

A-HS29 “Y”, “G”, and “J” Voltage Operation Sequence

This is the sequence of operation for HS29 “Y” voltage units. The HS29 “G” voltage sequence is the same; however the “J” voltage units have an outdoor fan transformer. The sequence is outlined by numbered steps which correspond to circled numbers on the adjacent diagram.

NOTE- The thermostat used may be electromechanical or electronic.

NOTE- Transformer in indoor unit supplies power (24 VAC) to the thermostat and outdoor unit controls.

COOLING:

- 1 - Cooling demand initiates at Y1 in the thermostat.
- 2 - 24VAC energizes compressor contactor K1.
- 3 - K1-1 N.O. closes energizing compressor (B1) and outdoor fan motor (B4).
- 4 - Compressor (B1) and outdoor fan motor (B4) begin immediate operation.

END OF COOLING DEMAND:

- 5 - Cooling demand is satisfied. Terminal Y1 is de-energized.
- 6 - Compressor contactor K1 is de-energized.
- 7 - K1-1 opens and compressor (B1) and outdoor fan motor (B4) are de-energized and stop immediately.

HS29 SINGLE-PHASE OPERATING SEQUENCE (SCROLL COMPRESSORS)

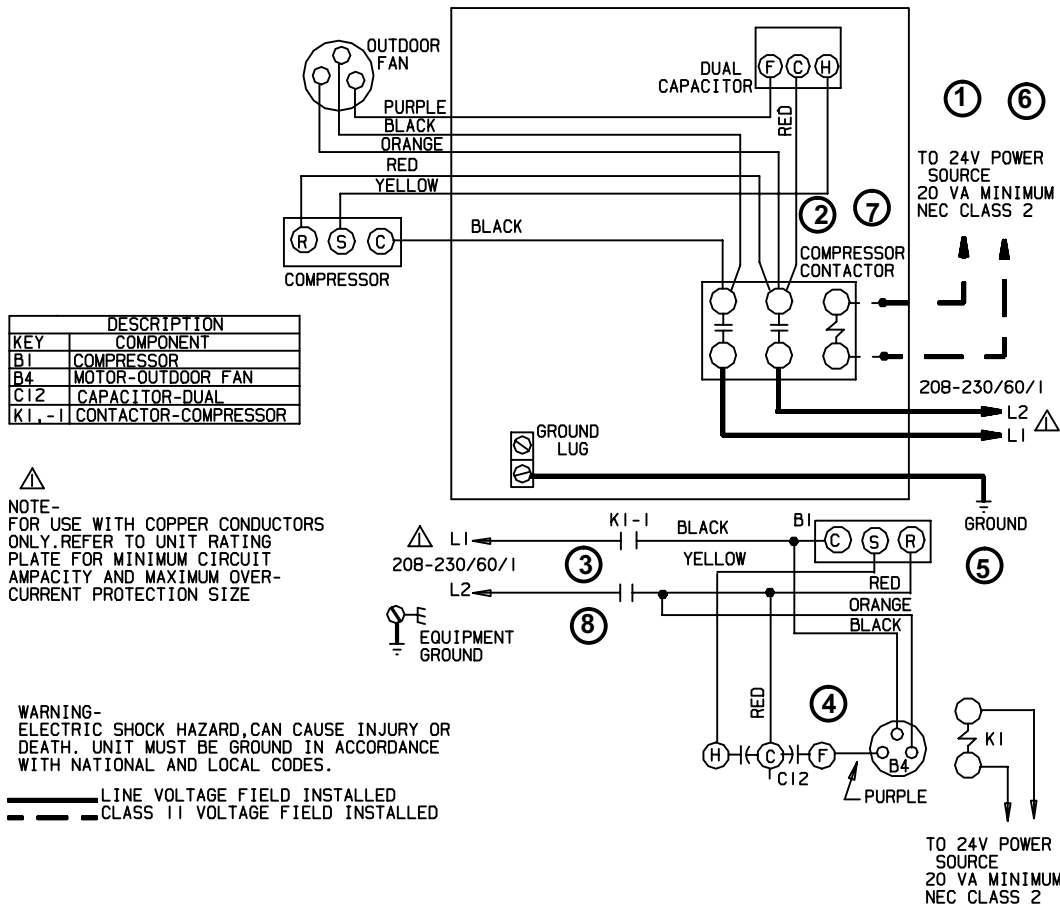

A-HS29 “P” Voltage Operation Sequence

This is the sequence of operation for HS29-030/036/042/048/060 “P” voltage units. The sequence is outlined by numbered steps which correspond to circled numbers on the adjacent diagram.

NOTE- The thermostat used may be electromechanical or electronic.

NOTE- Transformer in indoor unit supplies power (24 VAC) to the thermostat and outdoor unit controls.

COOLING:

- 1 - Cooling demand initiates at Y1 in the thermostat.
- 2 - 24VAC from indoor unit energizes compressor contactor K1.
- 3 - K1-1 N.O. closes, energizing terminal “C” of compressor (B1) and outdoor fan motor (B4).
- 4 - Outdoor fan motor (B4) begins immediate operation.
- 5 - Compressor (B1) begins operation.

END OF COOLING DEMAND:

- 6 - Cooling demand is satisfied. Terminal Y1 is de-energized.
- 7 - Compressor contactor K1 is de-energized.
- 8 - K1-1 opens and compressor (B1) and outdoor fan motor (B4) are de-energized and stop immediately.