

NINTENDO
POWER

THE ONLY GUIDE FROM

Nintendo

POKÉMON

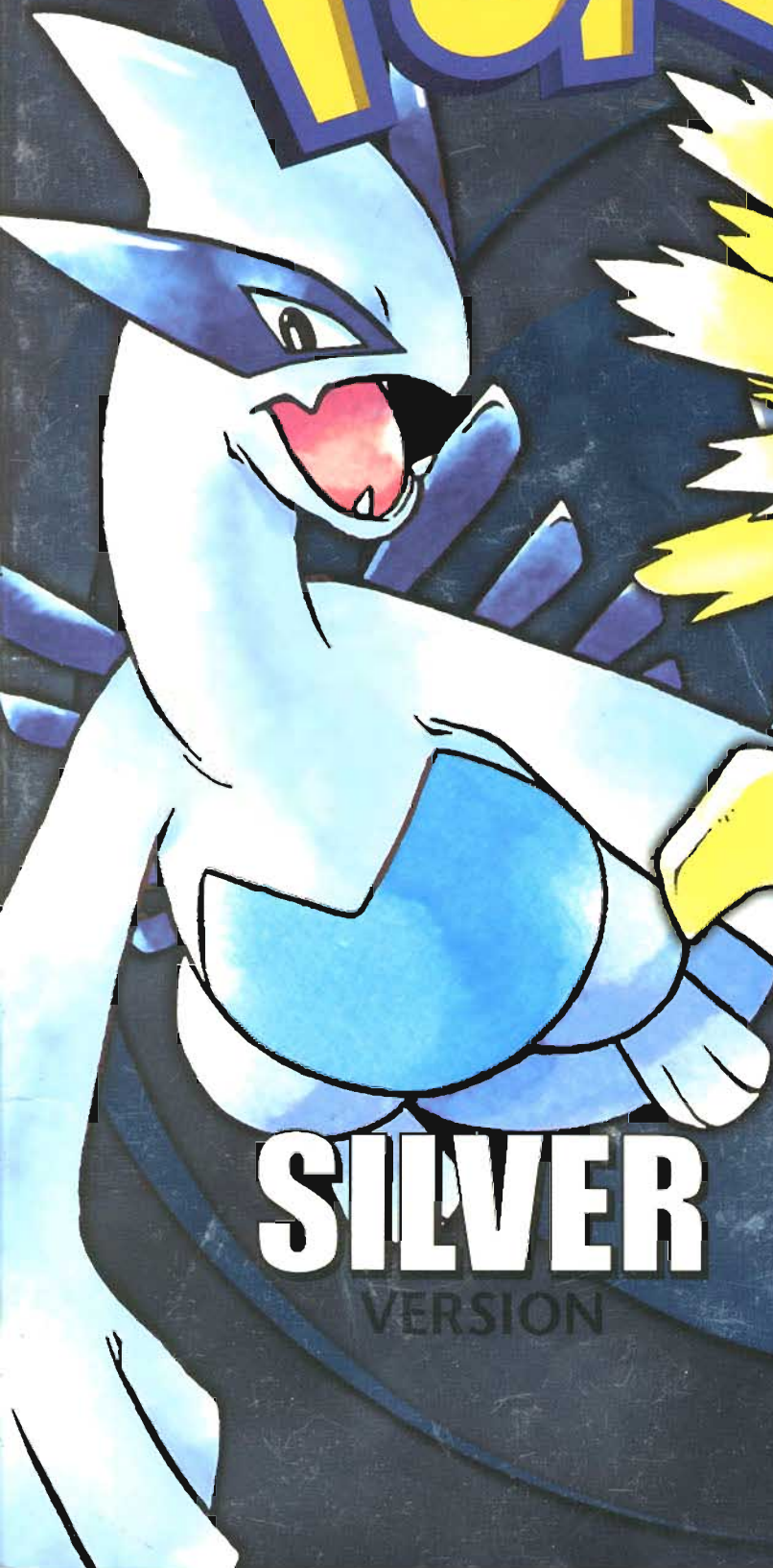

SILVER
VERSION

GOLD
VERSION

OFFICIAL

Nintendo

PLAYER'S GUIDE

Staff List

Publisher
M. Arakawa

Associate Publisher
Yoshio Tsuboike

Editor in Chief
Scott Pelland

Lead Writer
Jennifer Villarreal

Writers
Alan Averill
Jason Leang
Drew Williams

Editor/Producer
Jessica Joffe

Production Coordinator
Carina Agbanog

Art Director
Kim Logan

Lead Designer
Carol Walter

Strategic Layout
Work Mouse Co., Ltd.
Jumpin' Jack Yushi
Masahiro Furuse
Tatsuya Hoshi
Hiroyuki Kadouchi
Toru Nakagawa
Shigehiko Takahashi

Electronic Progress
Tim Garret
Joel Harris
Rebekah Lane

V-Design, Inc.
Yoshi Orimo
Sanja Morris
Oliver Crowell

Andy Myers
Estela Sandoval
Van Williams

Prepress Assistant
Christopher Shepperd

Sales and Marketing Manager
Jeff Batas

Advertising Coordinator
Malinda Miller

Production Specialist
Machiko Oehler

Special Thanks to Creatures and
GAME FREAK and Nintendo of
America's Pokemon Group.

The Pokemon Gold Version and Silver Version
Player's Guide is printed in the U.S.A. and pub-
lished by Nintendo of America Inc., 4820 150th
Ave. NE, Redmond, Washington 98052, or \$34.99 in
the U.S.A. (\$37.99 in Canada). ©2000 Nintendo of
America Inc. All rights reserved. Nothing that
appears in the Pokemon Gold Version and Silver
Version Player's Guide may be printed in whole or
in part without express written permission from
Nintendo of America Inc., copyright owner.™ and
® are trademarks of Nintendo of America Inc.
Pokemon ©1995-2000 Nintendo/Creatures
inc./GAME FREAK inc. ISBN 1-930206-04-6



The Official Nintendo Player's Guide

POKÉMON

GOLD VERSION
SILVER VERSION

Contents

- 4 World Map
- 6 Rise of the Pokémaster
- 10 Battle Strategies
- 14 Catch 'Em All



Trainer's Manual

- 16 Game Play Checklist
- 19 Using Your Trainer's Manual

Areas In Johto

- | | | | |
|----|------------------------|----|------------------------------|
| 20 | New Bark Town | 40 | Tin Tower |
| 21 | Route 29 | 41 | Routes 38 & 39 |
| 22 | Cherrygrove City | 42 | Olivine City |
| 23 | Routes 30 & 31 | 43 | Lighthouse |
| 24 | Violet City | 44 | Routes 40 & 41 |
| 25 | Sprout Tower | 45 | Whirl Island |
| 26 | Route 32 | 46 | Cianwood City |
| 27 | Ruins of Alph | 47 | Route 42 & Mt. Mortar |
| 28 | Union Cave | 49 | Mahogany Town |
| 29 | Route 33 & Azalea Town | 50 | Route 43 & Lake of Rage |
| 30 | Slowpoke Well | 51 | Rocket Hideout |
| 31 | Ilex Forest & Route 34 | 52 | Radio Tower & Underground |
| 32 | Goldenrod City | 54 | Route 44 |
| 35 | Route 35 | 55 | Ice Path |
| 36 | National Park | 56 | Blackthorn City |
| 37 | Routes 36 & 37 | 57 | Dragon's Den, Routes 45 & 46 |
| 38 | Ecruteak City | 58 | Dark Cave |
| 39 | Burned Tower | | |



Areas In Kanto

- | | | | |
|-----------|---|-----------|---|
| 58 | Routes 26 & 27 | 71 | Celadon City |
| 60 | Victory Road, Indigo Plateau & Route 23 | 72 | Routes 16, 17 & 18 |
| 61 | Vs. Elite Four | 73 | Fuchsia City |
| 62 | S.S. Aqua | 74 | Routes 11, 12 & 13 |
| 63 | Vermillion City | 75 | Routes 14 & 15, Route 2 |
| 64 | Route 6 & Saffron City | 76 | Pewter City |
| 65 | Route 8 | 77 | Route 3 & Mt. Moon |
| 66 | Lavender Town | 78 | Route 4 & Viridian City |
| 67 | Routes 9 & 10, Rock Tunnel | 79 | Pallet Town & Route 1 |
| 68 | Cerulean City | 80 | Cinnabar Island, Seafoam Island, Routes 19, 20 & 21 |
| 69 | Routes 24 & 25, Route 5 | 81 | Route 22 & Route 28 |
| 70 | Diglett's Cave, Route 7 | 82 | Mt. Silver |



Data File

- | | | | |
|------------|------------------------------|------------|---|
| 84 | Gotta Catch 'Em All | 102 | Johto Phone Call Map |
| 88 | Building Levels | 104 | Johto Tree Map |
| 90 | Trade Transformations | 106 | Kanto Weekly Event, Phone Call and Tree Map |
| 91 | Stepping Stones of Evolution | 108 | Item List |
| 92 | Friendly Evolution | 113 | Technical & Hidden Machine List |
| 93 | In-Game Events | 114 | Abilities & Attacks |
| 94 | Pokémon Eggs | 119 | Pokémon Locator |
| 96 | Pokémon Relocation | 120 | Pokémon Combat Chart |
| 98 | Rare Pokémon | 120 | Pokémon Index |
| 100 | Johto Weekly Event Map | | |

World Map

Your Pokémon adventure begins in New Bark Town, located in the new world of Johto. Pokémon Gold & Silver also feature the world of Kanto, which Ash explored in Pokémon Red, Blue and Yellow. To reach parts of Kanto, you must be able to Surf to Route 26, ride the S.S. Aqua or take the train from Goldenrod City.

JOHTO

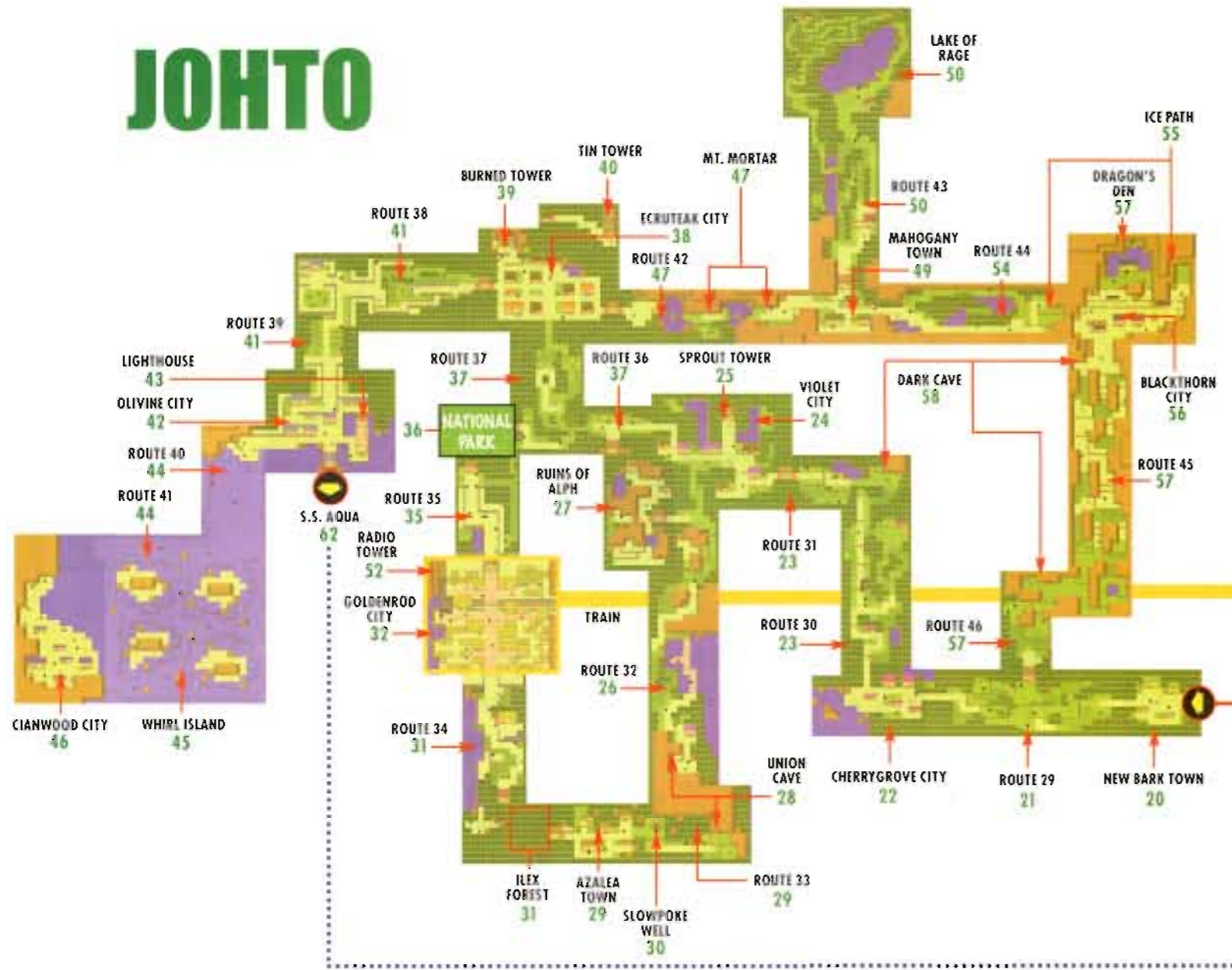

KANTO

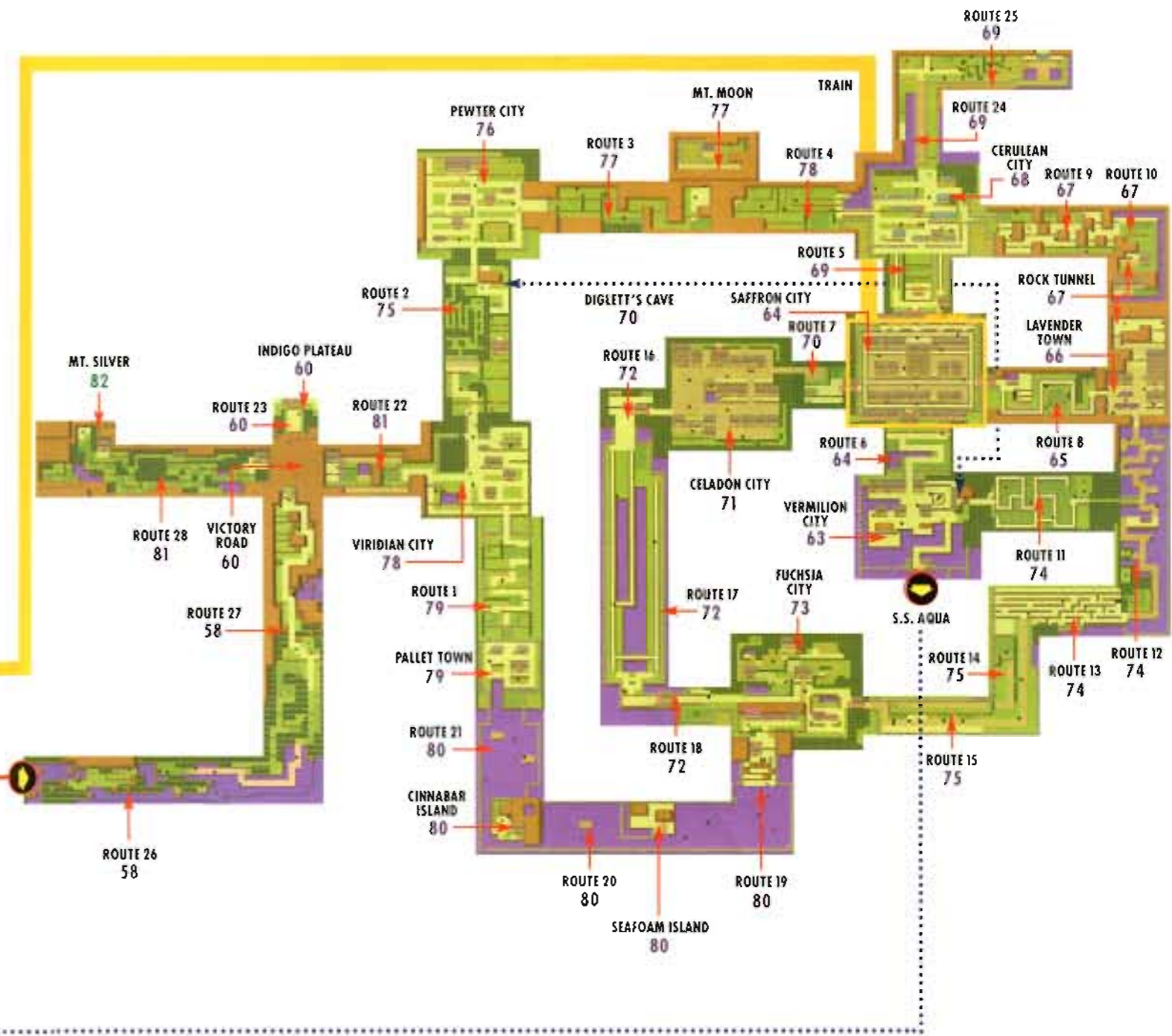

Rise of the Pokémaster

The life of a Trainer is an adventure filled with battles, travels and discoveries. You'll need to depend on your Pokémon to see you through the many challenges you'll face, so learn to use them wisely. Though you may not know much when you begin the journey, you can look to friends to teach you lessons along the way.

SHINY NEW ADVENTURES

The three previous versions of Pokémon—Red, Blue and Yellow—offer variations of the same exciting adventure. Each version omits certain Pokémon in the wild. You can't use them in battle unless you import them from another version. The Gold and Silver versions are very different from the other three, but they're similar to each other. The games unveil a new batch of Pokémon and adventures, and you can still trade some Pokémon with the earlier versions.



Designed to be played on the original Game Boy and Super Game Boy systems, the first three versions of Pokémon started the craze to catch 'em all.



Gold and Silver offer two versions of a brand-new, full-color adventure. Even experienced Trainers will find plenty of surprises and challenges.

METALLIC MARVELS

Gold and Silver sport a colorful new look and a slew of new Pokémon. You'll find the new additions scattered among the more familiar Pokémon as you make your way from battle to battle. Try your hand at new attacks and witness surprising evolutions while filling your Pokédex with the latest discoveries. Along with the advances in Pokémon studies comes technological innovation. Scientists have been hard at work concocting new inventions—like the multipurpose Pokégear your character wears on his wrist—and improving old ones to help you collect and maintain your Pokémon.



Some unfamiliar faces will pop up in the tall grass. Dozens of new Pokémon make their debuts, giving you reason enough to take up the Poké Ball again.

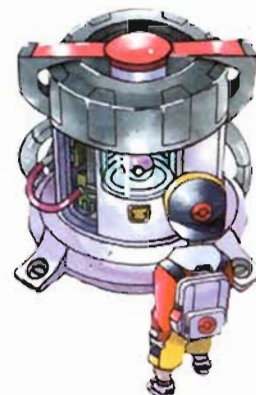

The Time Capsules in Gold and Silver allow you to trade Pokémon with the Red, Blue and Yellow versions. You can't use it right away, though. You'll have to earn it.



HERO

Red has already made a name for himself as Gold and Silver begins, so you'll have to step into the shoes of another promising—but untested—Trainer. It's up to you to prove his greatness.

RIVAL

What is this guy's problem? If you ask him, the problem is YOU. It's usually best to avoid people like him, but the game doesn't give you the option. Settle your conflicts with Pokémon.



Battle Your Way to the Championship

Until you start building up your Pokémon and winning battles, you're just one more ambitious Trainer in a world filled with like-minded enthusiasts. The other Trainers you'll meet will be happy to test your skills for small wagers and, sometimes, major prizes like Hidden Machines (HM). The battles will get tougher as you progress from town to town.



It takes more than skill to be a successful Pokémon Trainer. You'll need supplies. Stop by the Pokémon Mart to pick up Poké Balls and other goodies.

Stay sharp when you wander into new towns—there may be interesting challenges ahead. Seek out Gyms and other Trainer haunts.



Many of the people you'll meet just want to talk. Others want to do battle. You'll recognize the latter by the exclamation points that appear above their heads.

Even powerful Pokémon need first aid now and then. Take them to the Pokémon Center, where friendly attendants will administer the required TLC.

Support Group

BILL



You may remember Bill from Red, Blue and Yellow, but you might not have realized his major contributions to the world of Pokémon. His research made it possible to store Pokémon electronically.

MOM



Not only does Mom provide you with the moral support every Trainer needs, she helps you save money and buys you stuff. When you win money, send some to the First Bank of Mom.

PROF. OAK



Widely regarded as the preeminent expert on Pokémon, Professor Oak's consulting services are in high demand in Gold and Silver. He'll give you an important gift when you first meet him.

PROF. ELM



If Oak is the legendary master of Pokémon research, then Professor Elm is its rising star. It's lucky for you that his lab is right down the street from your house. Stop by when you start your adventure.

KURT



A short guy with a short name, Kurt is a renowned Poké Ball craftsman. Bring him your Apricorns so he can transform them into special balls for capturing particular Pokémon.

TRAINING TRENDS

In addition to introducing plenty of new Pokémon, Gold and Silver offer a variety of new ways to collect them and take care of them. Time plays a much more important role in the new adventures, and you'll need to embrace some new technologies and discoveries to get the most out of your adventure.

NEW POKÉDEX It looks an awful lot like a Game Boy Color, but the new Pokédex is a serious piece of scientific equipment. Like the old device, it puts important information about Pokémon at your fingertips, plus it has a new look and new features.

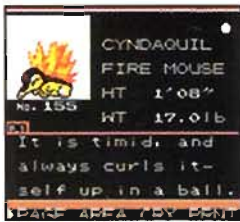
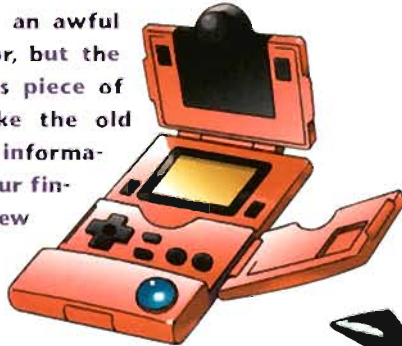

Pokémon are added to the Pokédex automatically when you have contact with them. Once you capture a particular Pokémon, you'll get more detailed information.



Evolutionary Mode



Numerical Mode



SWITCHING MODES

The default display mode in the Pokédex shows the proper evolutionary order of Pokémon when new evolutionary species, like Pichu, are added to the list. You can also view them in numerical order or alphabetically.

PACK It doesn't look very big, but you can put a lot of items into your backpack. Found items are automatically put into their proper compartments in the pack, so you can easily access them during battle. When you have more than one of a specific item, a number beneath it indicates the amount.



NEW DAY RISING The world keeps turning in Pokémon Gold and Silver even when you aren't playing the game. If you save your game in the daytime then continue it at night, you'll be standing in the same place but it will be dark outside.

Day



Night



When you enter the time and date at the beginning of the game, you'll start a cycle of days, nights and weeks that will continue as you play the game.



Certain Pokémon, like Hoothoot, are found in the wild only at night. Some events happen even less frequently, so pay attention to the day of the week.

POKÉGEAR

After you use your Pokégear for a while, you'll wonder how you ever got along without it. The device is a combination map, clock, calendar, cell phone and radio. It's often the first thing you reach for when you're stuck in the game.



It's always a good idea to check your map when you aren't sure where to go or what to do. It shows your position relative to nearby landmarks. You can also access the map in the Pokédex to show Pokémon habitats.



If you set up your game clock correctly, the day and time in the game should be the same as reality. It's good to know you can check, however.

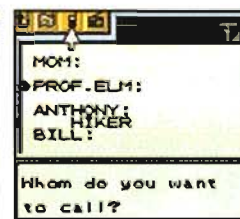

You won't have to remember phone numbers when you use the Pokégear's phone. Important people are listed on speed dial.



The radio is an optional feature of the Pokégear that you'll eventually earn. You'll find the subject matter compelling, even if you hate talk radio.

POKÉMON CENTER Most towns have Pokémon Centers that service your Pokémon needs. In addition to healing what ails your embattled creatures, the center also offers free storage, a Trade Center and a Colosseum.

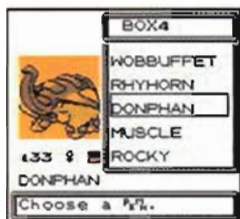

You can carry up to six Pokémon with you at a time. When you have a full load, captured Pokémon are automatically put in storage. Find a Pokémon Center PC to retrieve or deposit them.



If you need to settle a dispute or you just want to engage in a friendly sparring match, step up to the Cable Club Colosseum to battle another Trainer using a Game Link Cable.



If you want to trade Pokémon with another Trainer, hook up a Game Link Cable to his or her Game Boy then go to the Cable Club Trade Center.



POKÉMON EGG Pokémon researchers have uncovered exciting news about Pokémon reproduction. Pokémon eggs have been discovered in the wild, and it's starting to look like the unhatched creatures are produced by interaction between male and female Pokémon.



You'll notice during battle that most Pokémon have a gender symbol beside their name. Although most Pokémon are either male or female, some, such as Ditto, have no designation.

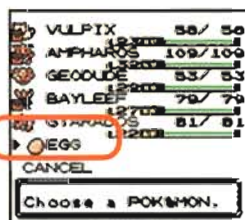

Anyone familiar with the Pokémon television series shouldn't be surprised that Togepi hatches from an egg, but it isn't an exceptional feat.



RED, BLUE, YELLOW

GOLD, SILVER



✓ YES

Any Pokémon found in Red, Blue or Yellow can be transferred to Gold or Silver.

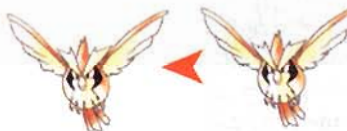

✓ YES

Any of the original 151 Pokémon can be transferred from Gold or Silver to Red, Blue or Yellow.



X NO

None of the new Pokémon found in Gold or Silver can be transferred to Red, Blue or Yellow.



X NO

None of the original 151 Pokémon with new abilities learned in Gold or Silver can be transferred to Red, Blue or Yellow.

MYSTERY GIFT After a girl in the Goldenrod City department store reveals the Mystery Gift function to you, it will appear on your game's Start menu. Find another Trainer then beam cool stuff to each other through your IR ports.



POKÉMON PIKACHU Pokémon Pikachu players also have many gifts to share. Use the Mystery Gift function in Gold or Silver to beam things like decorations between the two games.



POKÉDEX PRINTS If you want to keep a paper record of all the entries in your Pokédex, select the Print function on the bottom menu to print them using the Game Boy Printer.

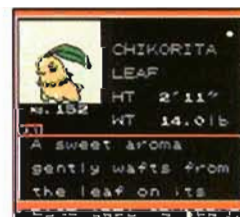

Battle Strategies

Pokémon love to fight, so you'll have to battle most of them before you'll be able to catch them. Learn how to put up a good fight by getting down the basics of battling.



HIT AND POWER POINTS

Your Pokémon's health is measured by its Hit Points, or HP. In battle, the damage your Pokémon takes will drain its HP. If its HP reaches zero, your Pokémon will faint and be out of commission until you treat it with a special item (like a Revive) or check it in at a Pokémon Center. Power Points, or PP, measure your Pokémon's abilities. The number of times you can use an attack depends on how many PP you have for that move. Every time you use an attack, you'll spend one PP, so choose your moves wisely.

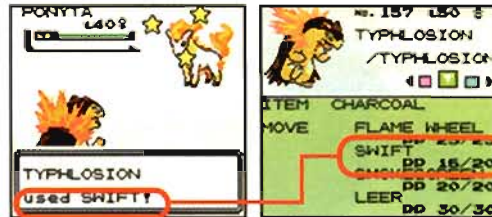

Every time you use an attack, your PP for that move goes down by one. If your PP for a move bottoms out at zero, you won't be able to use it.

SPECIAL EFFECTS

Most attacks take their toll on the victim's HP only. Other attacks are a little trickier and affect the targeted Pokémon's composure or inflict it with damage that lasts for the entire battle or until the effect is reversed. Those types of attacks are good to open with since they can help you weaken your opponent early. Attacks like Absorb can help you soak up your rival's HP, while a poison attack can continue to harm your opponent while you spend subsequent turns unleashing other attacks on it.



Some attacks continue to do damage throughout the battle. If your Pokémon is hit by one, the attack can drain all its HP, so beware.



If your Pokémon falls victim to an attack with long-lasting side effects, give it immediate attention before your Pokémon faints. Some attacks like poison ones will continue to hurt your Pokémon until you cure it with a special item or take it to a Pokémon Center.

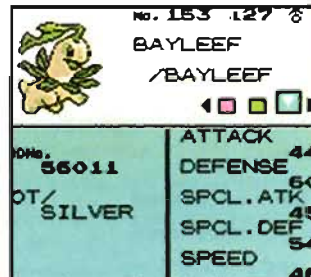

LEARNING FROM EXPERIENCE

After every battle you send your Pokémon into, your Pokémon will gain experience points (even if you call it back before it gets a chance to fight). As your Pokémon racks up experience points (EXP. Points), it will eventually mature to a new level. When Pokémon reach certain levels, they will automatically learn certain advanced moves. Enter all your Pokémon into as many battles as you can so they can develop new attacks and grow to new levels.

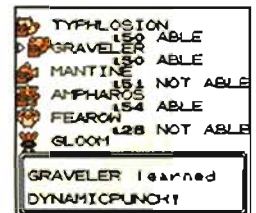
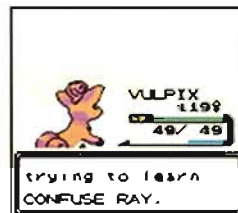

Your Pokémon can have four different attacks at one time, so you must make room for new moves if you want your Pokémon to learn a new attack.

You can also teach your Pokémon HMs and TMs. Your Pokédex will show you who can learn them.

IN THE HEAT OF BATTLE

Pokémon battles go down in one of two ways. Some Pokémon don't have owners, so you may encounter them in the wild. Other Pokémon have been trained, and you'll battle their Trainers to win experience points, money or even a badge.



WILD POKÉMON

Walk through grassy places, caves and other areas to find wild Pokémon. Once you've chosen the Pokémon you want to send into battle, the fighters will take turns attacking one another. You can't catch Pokémon that are owned by Trainers, but wild Pokémon are up for grabs. Catch one with a Poké Ball after weakening it or go ahead and defeat it if you want to earn even more experience points.

START

END

POKÉMON TRAINER

The routes are populated by Pokémon Trainers who are eager to compete with you. All Trainers, including yourself, can enter six Pokémon into a battle, so a matchup against a Trainer may last six rounds. After you've defeated one of the rival Trainer's Pokémon, you'll have a chance to call in another one of your Pokémon without losing a turn. If you defeat all of the Trainer's Pokémon, you'll win the battle along with some money and experience to boot!

START

END

WORST-CASE SCENARIOS

Battling isn't easy, so there's always a chance you'll find yourself struggling through a losing battle. If things are looking grim, swallow your pride and run. There's no penalty for leaving a battle with a wild Pokémon, so escape if you can. You can't escape a battle with a Trainer.

If you get wiped out and all of your Pokémon end up fainting, you will faint as well. You'll wake up in the last Pokémon Center you visited.

If the going gets tough, don't be afraid to run away. You can escape battles with wild Pokémon, so don't push it if you're close to being defeated.

TYPECASTING FOR COMBAT

In the previous games, there were 15 types to catch. Gold and Silver add two new types to the mix, bringing the total of Pokémon types to 17. Whatever type your Pokémon may be, it will sport some general characteristics that are directly related to its type. Water-types have aquatic abilities and characteristics, and they have a natural advantage over Fire-type Pokémon, which boast heat-related characteristics.

Pokémon have strengths and weaknesses based on their type. The effectiveness of your attack will depend on the type of both your Pokémon and the Pokémon it's fighting.



TWO NEW TYPES DARK & STEEL

In addition to the 15 Pokémon types featured in the Red, Blue and Yellow versions, Gold and Silver introduce two new types of Pokémon, Dark-type and Steel-type.

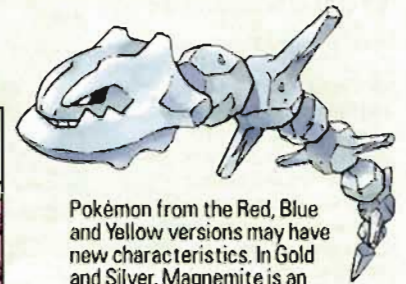

Pokémon from the Red, Blue and Yellow versions may have new characteristics. In Gold and Silver, Magnemite is an Electric-and-Steel-type.

COMBAT CHART

The chart below shows how effective different types of attacks are against different types of Pokémon. Match up the type of attack you want to use with the type of Pokémon you want to use it against to get a good idea of the outcome of your battle. A plus sign (+) means that your attack

will have an advantage. For example, a Water-type attack will give you the upper hand against a Fire-type Pokémon. A minus sign (-) means your attack won't be effective, an equal sign (=) means the attack will have no effect, while an empty box indicates the attack will have its standard effect.

		OPPONENT'S POKÉMON TYPE																
		NORMAL	FIRE	WATER	ELECTRIC	GRASS	ICE	FIGHTING	POISON	GROUND	FLYING	PSYCHIC	BUG	ROCK	GHOST	DRAGON	DARK	STEEL
YOUR ATTACK TYPE	NORMAL																	
	FIRE		-	-		+	+						+	-		-		+
	WATER		+	-		-				+				+		-		
	ELECTRIC			+	-	-					=	+				-		
	GRASS				+	-				-	+	-		+		-		-
	ICE					+	-			+	+					+		-
	FIGHTING		+					+									+	+
	POISON					+				-	-				-	-		=
	GROUND			+		+	-			+		=			-	+		+
	FLYING							+						+				-
	PSYCHIC								+	+							=	-
	BUG					+							+				+	-
	ROCK			+				+			-	+	+					-
	GHOST													+		+		-
	DRAGON																+	-
	DARK																	-
	STEEL																	-

BALANCED ATTACKS

Your Pokédex rates your Pokémon in five categories: Attack, Defense, Speed, Special Attack and Special Defense. Each category measures a different characteristic crucial to battling (refer to the definitions below for specifics), so balance your attacks to cover all angles. Besides the addition of Dark- and Steel-type Pokémon, Gold and Silver also add a new twist by changing Poison-type assaults from Special attacks to physical attacks.

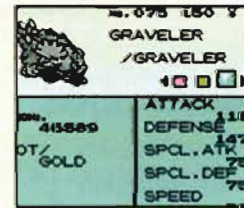

ATTACK Attack measures the power of physical attacks, which appear in orange on the chart.

DEFENSE How well your Pokémon can withstand a physical attack depends on its Defense rating.

SPEED The Speed rating determines who attacks first. The Pokémon with the higher Speed rating gets the first move.

SPECIAL ATTACK Nonphysical attack power is measured by the Special attack rating. Special attacks appear in blue on the chart.

SPECIAL DEFENSE Your Pokémon's ability to withstand Special Attacks is determined by its Special Defense rating.

ATTACK ADVANTAGE

Dual-type Pokémon (like Water-and-Flying-type, Gyarados) can have a double advantage, since they boast two sets of characteristics. But they can also be at a double disadvantage if you pit the right Pokémon against it. In the example, Electric-type Pikachu boosts its Thunderbolt attack by 1.5 times since both the attack and the Pokémon are of the same type. The attack strength is then multiplied by two since Electric-types have an advantage over Water-types. But that's not all—Electric-types also dominate over Flying-types, so the total damage is multiplied by two yet again!

EXAMPLE:
PIKACHU VS. GYARADOS

THUNDERBOLT ATTACK	x1.5
ELECTRIC VS. WATER	x2
ELECTRIC VS. FLYING	x2
TOTAL DAMAGE	x6

TEAM TACTICS

To guarantee that you have the perfect Pokémon for every battle, you should assemble a well-rounded team of all types. It's also a good idea to have at least one Pokémon with a low experience level. That way, you'll have a Pokémon you can use for battling wild Pokémon. If you battle them using one of your experienced team members instead, you might defeat the wild Pokémon before you have a chance to capture them.



Pokémon go into battle one at a time. The Pokémon at the top of your list will be the first one to enter the fight.



You can switch Pokémon during battle. Call in a substitute when your current Pokémon is close to fainting.



Put an inexperienced Pokémon at the top of your list to build its level. As long as it enters a battle (you can call it back before it fights), it will gain experience.



Attacks with longer-term effects such as Thunder Wave or Poison Powder can also help you get an advantage if you happen to be matched up against a Pokémon type that has the upper hand.



If you're attacked by a lasting attack that puts your Pokémon to sleep or burns it, you'll be under its spell or feel the burn until you cure the Pokémon or the effect wears off.

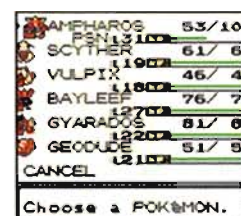

If your Pokémon is a victim of a lasting attack, pull it out of battle before it faints or heal it with an item. Sleep and Confusion are the only two effects that wear off—the others last until your Pokémon is healed.

Sample Team

You can gather up to six Pokémon for your team. Since every type of Pokémon has a unique natural advantage over other types, you should assemble six diverse Pokémon. Avoid putting together a team made up of one or few types. Instead, assemble a motley crew like the sample team so you can cover many bases.



VULPIX
FIRE



MAREEP
ELECTRIC



CHIKORITA
GRASS



GASTLY
POISON/
GHOST



GEODUDE
ROCK/
GROUND



PIDGEY
NORMAL/
FLYING



Catch 'Em All!

To be a Pokémaster, you have to know how to catch 'em all, and collecting Pokémon is a lot tougher than collecting other things like, say, stamps. Besides, knowing how to lick 'em all will help you only in battle. Be a true master by familiarizing yourself with more than just battle strategies. Master the art of catching Pokémon.



SEVEN WAYS TO GET POKÉMON

To fill up your Pokédex, you must see every Pokémon out there. You can catch some, while other Pokémon will appear only through evolution. In either case, you must have plenty of Poké Balls on hand for storing them. Poké Balls come in different strengths, so stock up on the good ones to make catching 'em all a manageable pursuit.

1. WILD POKÉMON



Free-roaming Pokémon often lurk in grassy areas and caves. Scour the thick greenbelts to find a wild Pokémon ready for battle. Weaken it, then capture it.

2. FISHING



The sea is flooded with Pokémon. Stand at the shore and try your luck fishing for a new Pokémon to round out your collection. You can also encounter Pokémon when you surf.

3. SPECIAL SITUATIONS



Key events in the game can also add a Pokémon to your party. Trading with townspeople or playing games like the slot machine can get you a step closer to earning a new addition.

4. LEVEL-UP EVOLUTION



Pokémon can also evolve into other Pokémon. The most basic way to evolve one is by entering it into many battles and building up its level.

5. STONE EVOLUTION

While some Pokémon evolve when they reach a certain level, others must be exposed to stones with elemental powers.

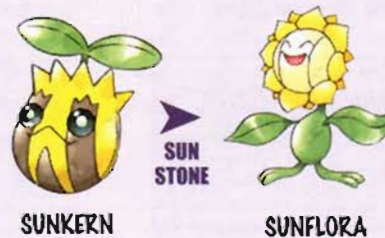

6. LINK-TRADE EVOLUTION

Pokémon is about trading as well as collecting. Certain Pokémon, like Haunter, evolve when you trade them using the Game Link Cable.



7. FRIENDSHIP EVOLUTION

If a Pokémon really likes you, it may evolve. Use it in battle often, never let it faint and groom it to stay on its good side.

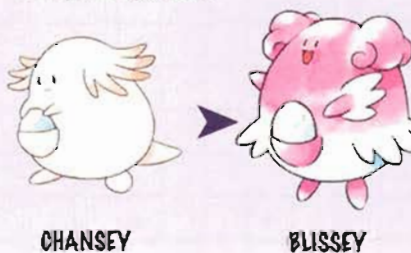

Your Pokédex lists all of the Pokémon you've encountered. The object is to catch as many different Pokémon as you can, so battle, trade, evolve or even fish for them to complete your Pokédex.

All sorts of colorful and exciting Pokémon live in the wild. Keep some Poké Balls handy since you'll have a good chance of running into many different species on your journey. For more details on what kinds of Pokémon are lurking in the wild and where you should go to find them, flip ahead to page 84.





Game Play Checklist

There are many events to keep up with in Pokémon Gold and Silver. Use the Game Play Checklist below to keep track of your progress and as a loose guide to the major events in the games. If you accomplish everything on the list, you've done a good job of covering the essential game play elements of Pokémon Gold and Silver.

Check off items as you finish them.

Johto

NEW BARK TOWN, page 20

- Choose a starting Pokémon from Professor Elm's lab

CHERRY GROVE CITY, page 22

- Pick up the town map from the old man

ROUTE 30, page 23

- Get the Mystery Egg from Mr. Pokémon
- Receive the Pokédex from Professor Oak

CHERRY GROVE CITY, page 23

- Fight the first duel with Rival



NEW BARK TOWN, page 20

- Take the Mystery Egg to Professor Elm's lab
- Receive your first Poké Balls

VIOLET CITY, page 24

- Defeat Falkner, the Gym Leader, and receive the Zephyr Badge and TM 31
- Pick up the Mystery Egg from Professor Elm's assistant in the Pokémon Center



SPROUT TOWER, page 25

- Get HM 05 from the Elder



ROUTE 32, page 26

- Get the Old Rod at the Pokémon Center

RUINS OF ALPH, page 27

- Catch three Unown to earn the Unown Pokédex



AZALEA TOWN, page 29

- Help Kurt save the Slowpoke
- Receive the Lure Ball from Kurt
- Defeat Bugsy, the Gym Leader, to get the Hive Badge and TM 49
- Fight the second battle with Rival



ILEX FORREST, page 31

- Catch Farfetch'd and return it to the Charcoal Maker to get HM 01
- Get TM 02 from the person in the middle of the forest



GOLDENROD CITY, page 32

- Pick up a bike at the Bike Shop
- Receive a Radio Card at the Radio Station
- Get the Coin Case in the Underground Path
- Defeat the Gym Leader, Whitney, to get the Plain Badge and TM 45

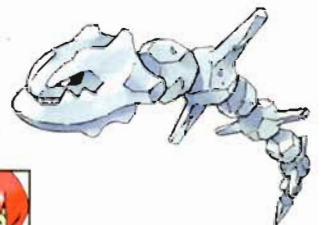

- Pick up the Squirtbottle in the woman's house

ROUTE 36, page 37

- Water the tree with the Squirtbottle to clear the path
- Pick up TM 08 from the man in the road

ECRUTEAK CITY, page 38

- Receive HM 03 from the man at the Dance Hall
- Pick up the Item Finder at the house
- Defeat the Gym Leader, Morty, to get the Fog Badge and TM 30
- Fight the third Rival battle



OLIVINE CITY, page 42

- Get the Good Rod from the Fisherman
- Meet Jasmine in the Lighthouse
- Get HM 04 from the Sailor

CIANWOOD CITY, page 46

- Pick up the Secret Potion at the Pharmacy
- Defeat Chuck, the Gym Leader, to win the Storm Badge and TM 01
- Get HM 02 from the Gym Leader's wife



LIGHTHOUSE, page 43

- Heal the Ampharos with the Secret Potion



OLIVINE CITY, page 42

- Defeat the Gym Leader, Jasmine, and receive the Mineral Badge and TM 23

LAKE OF RAGE, page 50

- Defeat or catch the Red Gyarados and get the Red Scale
- Meet up with Lance and follow him to Mahogany Town

MAHOGANY TOWN, page 49

- Destroy Team Rocket's Hideout
- Get HM 06 from Lance
- Defeat Pryce, the Gym Leader, and receive the Glacier Badge and TM 16



RADIO TOWER/UNDERGROUND, page 52

- Pick up the Basement Key from the Fake Radio Station Manager
- Rescue the real Station Manager in the Underground Path
- Get either the Silver Wing (Silver) or the Rainbow Wing (Gold) from the Station Manager
- Receive TM 11 from the woman in the Radio Station
- Fight the fourth Rival battle



ICE PATH, page 55

- Pick up HM 07, which is lying on the ground

BLACKTHORN CITY, page 56

- Defeat Clair, the Gym Leader
- Find the Dragon Fang in the Dragon Den to receive the Rising Badge and TM 24

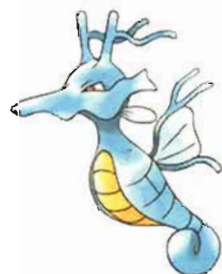

NEW BARK TOWN, page 20

- Pick up the Master Ball from Professor Elm

VICTORY ROAD, page 60

- Fight the fifth Rival battle



INDIGO PLATEAU, page 60

- Battle with the Elite Four and the Champion, Lance



Kanto

NEW BARK TOWN, page 20

- Get the S. S. Ticket from Professor Elm

OLIVINE CITY, page 42

- Board the S.S. Aqua at Olivine's port

S.S. AQUA, page 62

- Find the Sailor who is slacking off to clear a path belowdecks
- Locate the missing child and receive Metal Coat from her grandfather as a reward

VERMILION CITY, page 63

- Defeat Lt. Surge, the Gym Leader, to earn the Thunder Badge

SAFFRON CITY, page 64

- Battle Sabrina, the Gym Leader, to win the Marsh Badge

ROUTE 10, page 67

- Talk to the man at the Power Plant to find out what happened there

CERULEAN CITY, page 68

- Run into a suspicious-looking man in the Gym

ROUTE 24, page 69

- Follow the man up to Route 24 and battle him to learn where the Machine Part is

ROUTE 25, page 69

- Find Cerulean City's Gym Leader, Misty, who is on a date

CERULEAN CITY, page 68

- Fish out the Machine Part from the water inside the Gym
- Defeat Misty to earn the Cascade Badge

ROUTE 10, page 67

- Receive TM 07 from the Plant Manager

LAVENDER TOWN, page 66

- Pick up the Expansion Card in the Radio Tower

SAFFRON CITY, page 64

- Talk with Copycat about her missing Poké Doll



VERMILION CITY, page 63

- Retrieve the Poké Doll from the Pokémon Fan Club

SAFFRON CITY, page 64

- Take the Poké Doll to Copycat and receive the Pass for the train as a thank-you



CELADON CITY, page 71

- Fight the Gym Leader battle with Erika, and earn the Rainbow Badge and TM 19

FUCHSIA CITY, page 73

- Battle Janine, the Gym Leader, and receive the Soul Badge and TM 06

ROUTE 12, page 74

- Get the Super Rod from the fisherman's brother

VERMILION CITY, page 63

- Wake Snorlax with the Poké Flute music on the radio

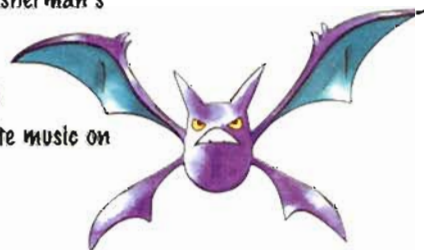

PEWTER CITY, page 76

- Get the Rainbow Wing (Silver) or the Silver Wing (Gold) from the old man
- Battle the Gym Leader, Brock, to win the Boulder Badge

MT. MOON, page 77

- Fight the sixth battle with Rival



CINNABAR ISLAND page 80

- Meet Blue on Cinnabar Island

SEAFOAM ISLAND page 80

- Defeat Cinnabar Island's Gym Leader, Blaine, to win the Volcano Badge

VIRIDIAN CITY, page 78

- Defeat Blue, the Gym Leader, to get the Earth Badge

PALLET TOWN, page 79

- Talk to Professor Oak to be admitted to Mt. Silver

MT. SILVER, page 82

- Battle Red to become Champion

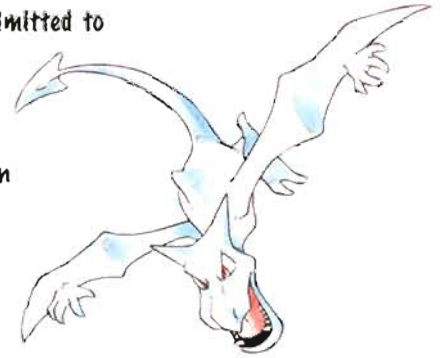

Using Your Trainer's Manual

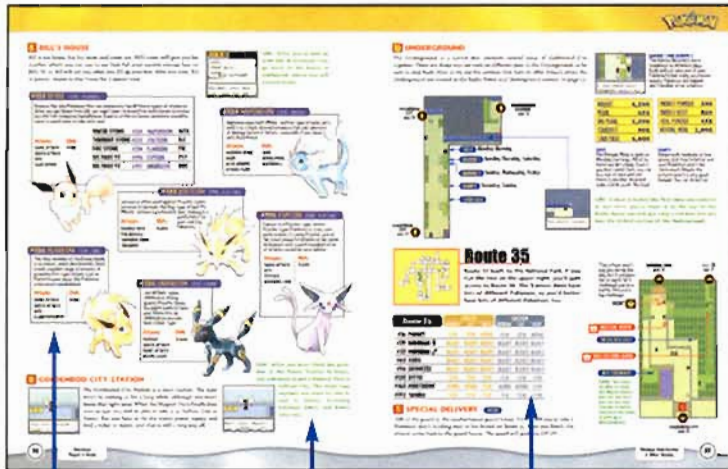

POKÉMON BOX

The Pokémon's name, number and type are listed first. A small description explains something interesting about the creature. A list of recommended attacks is provided to help you train your Pokémon.

Later: Any events that occur in a particular area some time after your first visit to that area are highlighted with green text and the "Later" label.

POKÉMON CHART

The Pokémon Chart lists the Pokémon name and number of most of the wild Pokémon you will find in any area. It's divided into Morning, Day and Night sections. The likelihood of finding a Pokémon during a certain time on both Gold and Silver is indicated by many, few and none.

WORLD MAP

The World Map displays where the cities, towns, routes, islands and caves are located in relation to the entire area of either Johto or Kanto.

GYM LEADER

The Gym Leader boxes are always labeled for quick and easy reference and contain info on which Pokémon to use in battle and other tips.



RIVAL

Every Rival battle is set off in its own box. Each box shows the Pokémon your rival will use in battle.

MAP KEY

- ROUTE 29** page 21 The arrows point to adjacent areas not pictured
- Poké** Pokémon Center
- Gym** Pokémon Gym
- Mart** Pokémon Mart
- ITEMS** The blue labels and arrows point out the locations of items.

- PHONE CALL** The Phone Icon next to a person's name indicates that you can exchange numbers with him or her to keep in touch.

- A** Doors that link rooms or that should be opened in order are marked with letters starting with "A."

- RIVAL!** The location of your Rival in the area is marked with an exclamation point on the map.



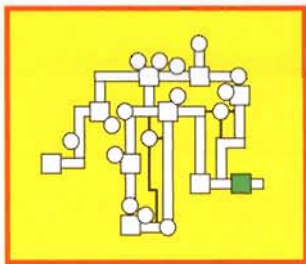

New Bark Town

Your hometown of New Bark Town may be small, but it's packed with places, people and items that are extremely important to you. Your adventure begins with an errand that your neighbor, Professor Elm, asks you to run for him. He gives you a wonderful gift for helping him!

1 ON THE HOME FRONT POKÉ GEAR

The very first item you will receive is your Pokégear, which your mother says is back from the repair shop. The Pokégear is a multifunctional device that initially acts as a phone. With it, you can call important people like your mother or your neighbor, Professor Elm. Your mother will explain how to use the device, and she'll also help you set the day of the week. After she's done helping you, your mother will send you to Professor Elm's lab.



Before your mom sends you over to Professor Elm's lab, she will give you the Pokégear and her phone number, so you can call her anytime you'd like.

Later: While you're on your journey, your Mom will help you save your money if you want her to. You can't lose money your mom keeps for you, and you can ask her for the saved money when you run low. Your mom loves to shop, and she will call you when she's purchased something new. Sometimes she buys helpful items, like Potion or Repel, and sometimes she just buys decorations for your room.



Your mom likes buying fun Pokémon stuff for your room, like the Charmander and Snorlax dolls, and you can use them to decorate. When you're in your room, choose Decoration from your PC's menu to arrange the objects.

2 PROFESSOR ELM'S LAB POTION POKÉ BALL x5 MASTER BALL EVERSTONE S.S. TICKET

Professor Elm asks you to visit Mr. Pokémon in Cherrygrove City to pick up an interesting item. He offers you one of his Pokémon—Chikorita, Cyndaquil or Totodile—to keep you company on your journey. The Professor will call you several times during your adventure, and each time he will have one of the gifts listed above for you. The lab assistants will give you your first five Poké Balls after you return from the errand. After you win your eighth badge in Johto, Professor Elm will call you back to the Lab and give you the Master Ball. Once you have defeated the Elite Four, Professor Elm will give you the S.S. Ticket so you can continue on to Kanto.



You may notice a red-haired person peering into the windows of Professor Elm's lab. If you start a conversation, you will annoy him and he will literally kick you out of his way. How mean!

Professor Elm will let you choose one of his three rare Pokémon to be your companion on the way to Mr. Pokémon's house. Choose wisely!



Later: Right after you've completed the errand, Professor Elm calls and asks you to rush back to the lab. He's too upset to tell you what happened, but you'll soon find out. On your way back to the lab, the mean, red-haired person challenges you to a battle, and the Pokémon he's using certainly seems familiar. It turns out he stole that Pokémon from Professor Elm. That's no way to behave!





#152 CHIKORITA TYPE: GRASS

Like Bulbasaur before it, Chikorita is a Grass-type that is strong against Rock-, Ground- and Water-types, and is weak against Fire-, Bug-, Poison- and Flying-types.

LEVEL 16 #153 BAYLEEF GRS

LEVEL 32 #154 MEGANIUM GRS

Attacks

RAZOR LEAF
SYNTHESIS
BODY SLAM
SOLAR BEAM

HMs

CUT
FLY
STRENGTH (#153, #154)



#155 CYNDAQUIL TYPE: FIRE

Charmander's successor is also a Fire-type, and it is strong when fighting against Ice-, Grass- or Bug-types and is weak when fighting against Water-, Rock- or Ground-types

LEVEL 14 #156 QUILAVA FIR

LEVEL 36 #157 TYPHLOSION FIR

Attacks

SMOKESCREEN
QUICK ATTACK
SWIFT
FLAMETHROWER

HMs

CUT
STRENGTH (#156, #157)

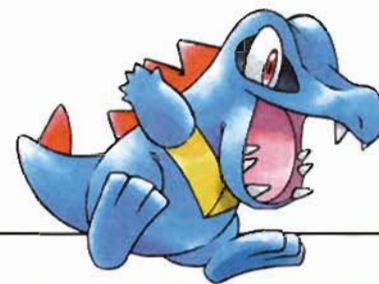

#158 TOTODILE TYPE: WATER

Totodile is a Water-type like Squirtle, and it is strong against Fire-, Ground- and Rock-types. It is weak when it faces Grass- or Electric-type Pokémon and sometimes other Water-types.

LEVEL 18 #159 CROCONAW WTR

LEVEL 30 #160 FERALIGATR WTR

Attacks

BITE
SLASH
SCREECH
HYDRO PUMP

HMs

CUT
SURF
WHIRLPOOL
STRENGTH (#159, #160)

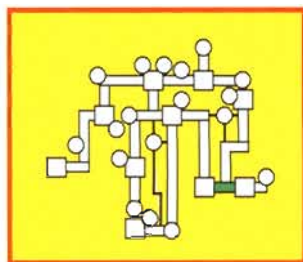

Route 29

Route 29 is a long and winding road that will eventually drop you off in Cherrygrove City. You have to walk through tall grass to make it to your next destination, so be ready to battle with some Pokémon! Unfortunately, you can't catch them without some Poké Balls.

Route 29

	GOLD			SILVER		
	MORNING	DAY	NIGHT	MORNING	DAY	NIGHT

#16 PIDGEY	MANY	MANY	NONE	MANY	MANY	NONE
#19 RATTATA	FEW	FEW	MANY	FEW	FEW	MANY
#161 SENTRET	MANY	MANY	NONE	MANY	MANY	NONE
#163 HOOTHOOT	NONE	NONE	MANY	NONE	NONE	MANY

1 THE DAY SIBLINGS PINK BOW

There are seven siblings who are located at various points in Johto. After you defeat Violet City's Gym leader, they will appear. Tuscany, the Tuesday sibling, appears on Route 29 every Tuesday. Remember to come back to Route 29 any Tuesday to meet her. Tuscany of Tuesday will give you the Pink Bow, an item that boosts the power of Normal-type moves, when you find her.

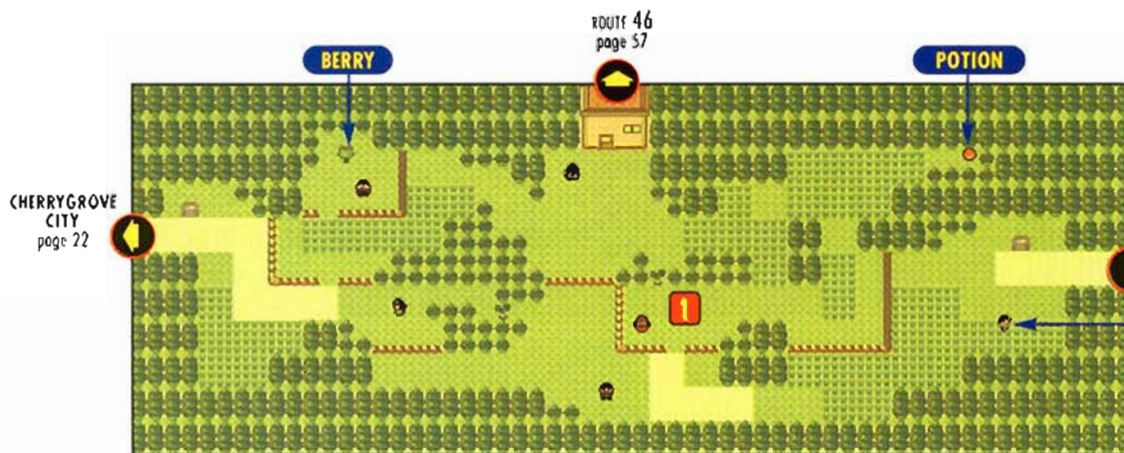

Later: After you complete Elm's errand, this person will explain how to use a Poké Ball.

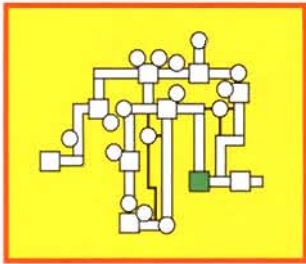

Cherrygrove City

Cherrygrove City has a Pokémon Mart and a Pokémon Center, but it doesn't have a Gym. You will have to battle in this city, however, so try to battle as many wild Pokémon as possible to build up your starting Pokémon and make it fighting fit.

1 TAKE THE TOUR

An old man will offer to show you around Cherrygrove City. It may seem like a small town, but take him up on his offer anyway, especially if you haven't played a Pokémon game before. After the nice older gentleman is finished showing you the sights, he will reward you with a Map Card for your Pokégear, so you'll have a map of Johto with you at all times. To use the map, hit the Start Button, select Pokégear from the menu then choose the Map icon.

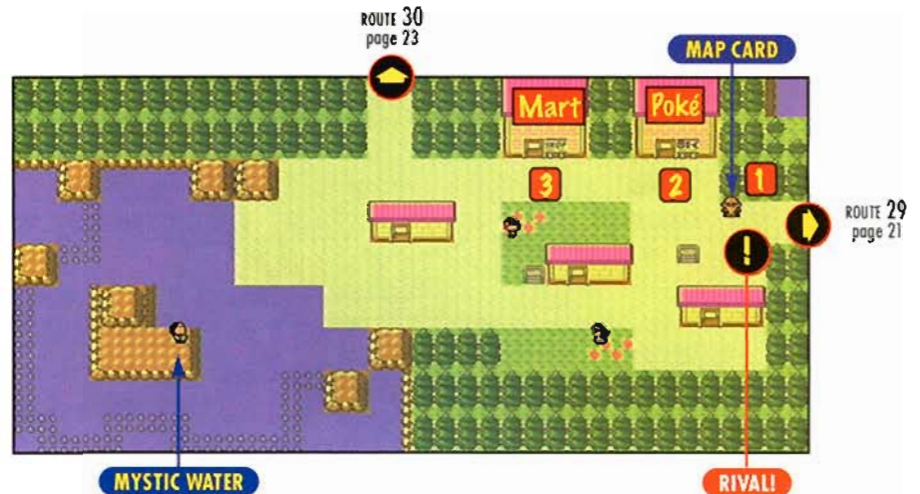

Mystic Water
Later: Once your Pokémon can learn Surf and you can use it outside of battles, head over to the island and talk to the fisherman. He will give you Mystic Water, which powers up Water moves.

2 POKÉMON CENTER

If you have never been to a Pokémon Center before, you're in for a treat. Pokémon Centers are located in nearly every town, and they are a great resource for Pokémon Trainers of all skill levels. You can ask the nurse at the desk to heal your Pokémon back to perfect health and you can use the PC there to access your PC, where you store your items, and Bill's PC, where you store your Pokémon.

Later: The second floor of every Pokémon Center has several areas that you won't be able to use until you've finished your errand for Professor Elm. The first area is the Cable Club Trade Center, where you can use the Game Link Cable to trade Pokémon with a friend who has Pokémon Gold or Silver. The second is the Cable Club Battle Center, where you can battle with a friend who has any Pokémon game.

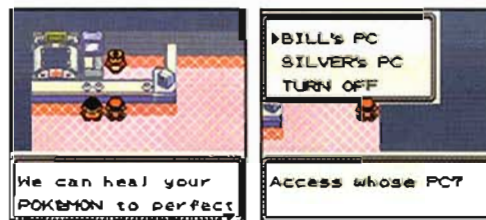

The Pokémon Center is the perfect place to get your Pokémon and items in order. You can also heal your Pokémon when they are tired and hurt from battle.

3 POKÉMON MART

The Pokémon Mart is a good place to stock up on items that you need to become a great Pokémon Trainer. If you visit the Pokémon Mart before you finish your errand for Professor Elm, you will not be able to buy Poké Balls. You can purchase other goods, however, if you wish to spend your money.

POKÉMON MART

POTION	300
ANTIDOTE	100
PARALYZE HEAL	200
AWAKENING	250
POKÉ BALL	200

Later: After you've successfully completed Professor Elm's errand, you can go back to the Pokémon Mart and purchase as many Poké Balls as you can afford. You must use the Poké Balls to catch Pokémon in the wild to bulk up your traveling party.



**RIVAL!
BATTLE 1**



- **CYNDQUIL**
- LEVEL 5 **TOTODILE** WATER
- **TOTODILE**
- LEVEL 5 **CHIKORITA** GRASS

- **CHIKORITA**
- LEVEL 5 **CYNDQUIL** FIRE

On your way back to Professor Elm's lab, you will run into your Rival in Cherrygrove City. His Pokémon will be whichever of the starting Pokémon your starting Pokémon is weak against, but it will be only at Level 5, so as long as you've beaten a bunch of wild Pokémon, you will win.



Route 30 & Route 31

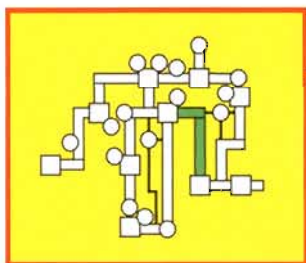

Route 30 and Route 31 are relatively uncomplicated roads—unfortunately, you'll have to wander off the path to make it to Mr. Pokémon's house to finish Professor Elm's errand. You'll be wandering through tall grass again, but it will help your Pokémon become strong—if you win.

Route 30

	GOLD			SILVER		
	MORNING	DAY	NIGHT	MORNING	DAY	NIGHT

#10 CATERPIE	MANY	MANY	NONE	NONE	NONE	NONE
#11 METAPOD	MANY	MANY	NONE	NONE	NONE	NONE
#13 WEEDLE	NONE	NONE	NONE	MANY	MANY	NONE
#14 KAKUNA	NONE	NONE	NONE	MANY	MANY	NONE
#16 PIDGEY	MANY	MANY	NONE	MANY	MANY	NONE
#19 RATTATA	NONE	NONE	MANY	NONE	NONE	MANY
#163 HOOTHOOT	NONE	NONE	MANY	NONE	NONE	MANY
#165 LEDYBA	NONE	NONE	NONE	MANY	NONE	NONE
#167 SPINARAK	NONE	NONE	MANY	NONE	NONE	NONE

Route 31

	GOLD			SILVER		
	MORNING	DAY	NIGHT	MORNING	DAY	NIGHT

#10 CATERPIE	MANY	MANY	NONE	NONE	NONE	NONE
#11 METAPOD	MANY	MANY	NONE	NONE	NONE	NONE
#14 KAKUNA	NONE	NONE	NONE	MANY	MANY	NONE
#16 PIDGEY	MANY	MANY	NONE	MANY	MANY	NONE
#19 RATTATA	NONE	NONE	MANY	NONE	NONE	MANY
#69 BELLSPROUT	MANY	MANY	MANY	MANY	MANY	MANY
#163 HOOTHOOT	NONE	NONE	MANY	NONE	NONE	MANY
#165 LEDYBA	NONE	NONE	NONE	MANY	NONE	NONE
#167 SPINARAK	NONE	NONE	MANY	NONE	NONE	NONE

1 BERRY GOOD! BERRY

A man inside the house will tell you about the healing properties of Berries. Search the tree outside the house with A to find another Berry. Your Pokémon can hold Berries to heal themselves!

2 MR. POKÉMON MYSTERY EGG POKéDEX EXPERIENCE SHARE

Mr. Pokémon will give you the Mystery Egg to take to Professor Elm. Mr. Pokémon's friend, Professor Oak, will give you a Pokédex. As you're leaving, Professor Elm will call you and ask that you return to the lab on the double. Later, trade the Red Scale from the Lake of Rage to Mr. Pokémon for Experience Share.

Later: A guard in the guard house that separates Goldenrod City and Route 35 will ask you to deliver a message to the man by the water. If you give the mail to the man, he will give you TM 50, Nightmare.

BITTER BERRY **TM 50 NIGHTMARE** **ANTIDOTE** **DARK CAVE** page 58

VIOLET CITY page 24

POKé BALL

BUG CATCHER: WADE

POISONCURE BERRY

Later: The first time you visit this area on your way to Mr. Pokémon's house, a Pokémon battle will be blocking the road and you won't be able to get through. The way will be clear after you finish the errand.

YOUNGSTER: JOEY

BERRY

CHERRY GROVE CITY page 22

I'm OAK! A POKÉMON researcher.

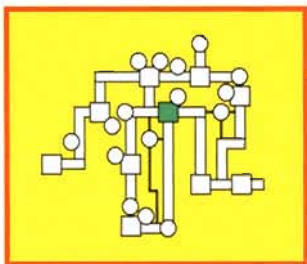

Violet City

Violet City is the first city you'll visit that has a Gym in it. You don't want to rely on just one Pokémon for a Gym Leader battle, so you'd better catch and raise some wild Pokémon to fill out your party. You won't be able to reach the items above the city until you have Surf.

1 EARL'S POKÉMON ACADEMY

If you talk to the man next to the Gym, he will lead you to his Pokémon Academy, where he teaches his students some basic Pokémon battling and raising lessons. You can also learn a lot from the writing on the blackboard and the other students. Study hard!



2 SPROUT TOWER

The Sprout Tower is a good place to train your Pokémon and yourself. If your Pokémon are over Level 10, the battles against the Grass-types won't be very difficult. If your Pokémon aren't at Level 10, it might be a little harder—unless you started with Cyndaquil.

3 VIOLET CITY GYM

It's your first Gym battle, so be careful. There are two Gym Members and one Gym Leader for you to fight, but you don't have to fight them without a break. If your Pokémon get too weak, take them to the Pokémon Center and heal them between battles, so they're able to continue.



VIOLET CITY GYM LEADER: FALKNER

LEVEL 7 PIDGEY NRM/FLY
LEVEL 9 PIDGEOTTO NRM/FLY

RECOMMENDED POKÉMON TYPES:
ROCK

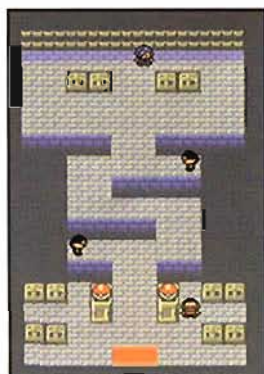

The battle with Falkner won't be a problem if you pick up an Onix in a trade. Falkner uses Normal-and-Flying-types Pidgey and Pidgeotto, which don't do well against Rock-types. They're especially vulnerable to Electric-types, but you probably won't have one this early in the game.

PRIZES: ZEPHYR BADGE/TM 31 (MUD-SLAP)

When you beat Falkner, he will award you the Zephyr Badge and TM 31, Mud-Slap. You can use a TM only once.

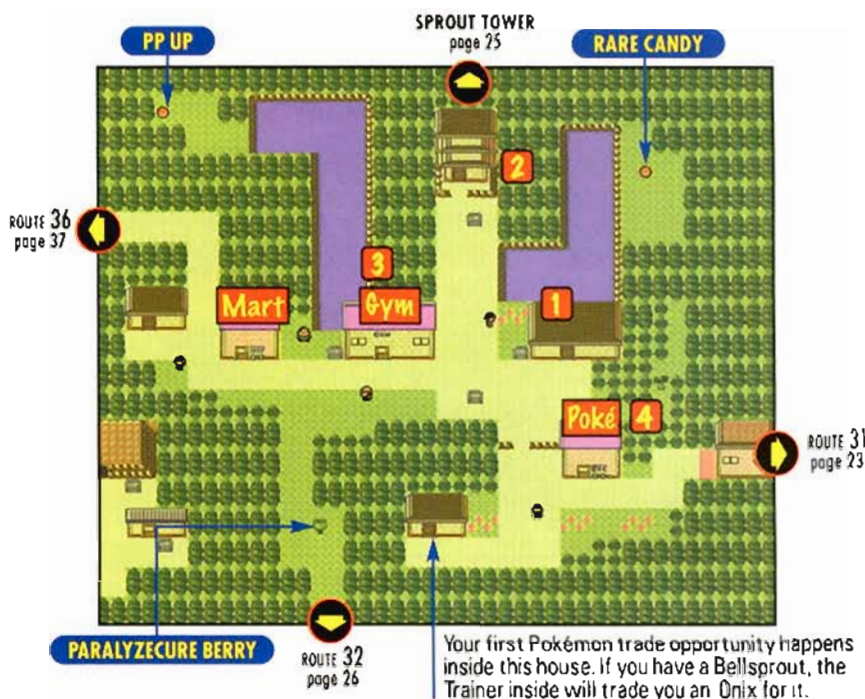

4 POKÉMON EGG

After you beat the Violet City Gym Leader, you will get a call from Professor Elm asking you to meet his assistant in the Violet City Pokémon Center. The assistant will give you



the Pokémon Egg you delivered to Elm, because it needs to be near active Pokémon to hatch. Put it in your party and keep it safe.

POKÉMON MART

POKé BALL	200
POTION	300
ESCAPE ROPE	550
ANTIDOTE	100
PARALYZE HEAL	200
AWAKENING	250
X DEFEND	550
X ATTACK	500
X SPEED	350
FLOWER MAIL	50

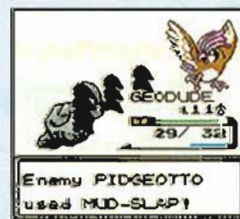

Sprout Tower

The magical Sprout Tower is rumored to have a giant Bellsprout stalk as its center column. Many monks devoted to Grass-types train in Sprout Tower, but you should be able to handle them. You may want to use the Escape Rope to leave the tower, or you can climb down.

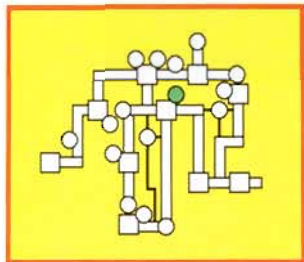

Sprout Tower

	GOLD			SILVER		
	MORNING	DAY	NIGHT	MORNING	DAY	NIGHT

#19 RATTATA	MANY	MANY	MANY	MANY	MANY	MANY
#92 GASTLY	NONE	NONE	MANY	NONE	NONE	MANY

FIRST FLOOR

PARALYZE HEAL



Follow the marked staircases to make your way up Sprout Tower. You can pick up Paralyze Heal on the right side of the first floor.

VIOLET CITY
page 22

SECOND FLOOR

X DEFEND

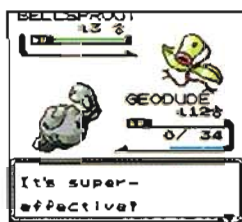
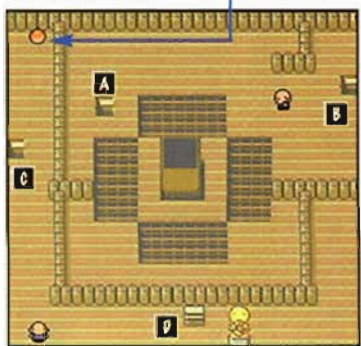

The monks will fight with mainly Grass-types, and they seem particularly fond of Bellsprout. Your Rock-, Water-, Grass- and Ground-types won't fare well against the Monks' Pokémon, unless you've trained them to Level 10 or above. Fire-types will have no trouble at all. You can find X Defend on the second floor of the Tower.

THIRD FLOOR

ESCAPE ROPE



1 THE ELDER

The third floor has several monks and their leader, the Elder. You will see your Rival briefly, but he leaves quickly. If you beat the Elder, he will give you HM 05, Flash, which will help you see inside dark caves. You need the Zephyr Badge to use Flash outside of battle.

POTION

#19 RATTATA TYPE: NORMAL

Rattata are very common in many areas, including Sprout Tower. The Normal-type Pokémon will pop out of Grass and appear inside buildings, and it doesn't seem to prefer daytime or nighttime.

LEVEL 20 #20 RATICATE NRM

Attacks

QUICK ATTACK
HYPER FANG
PURSUIT
SUPER FANG

HMs

STRENGTH (#20)



#92 GASTLY TYPE: GHOST/POISON

This Ghost-and-Poison type will appear in Sprout Tower at night. Gastly evolves to Haunter when it reaches Level 25. Trade your Haunter to evolve it to Gengar. Don't forget that the three are dual-types!

LEVEL 25 #93 HAUNTER GHO/PSN

TRADE #94 GENGAR GHO/PSN

Attacks

HYPNOSIS
CURSE
NIGHT SHADE
DREAM EATER

HMs

STRENGTH (#94)

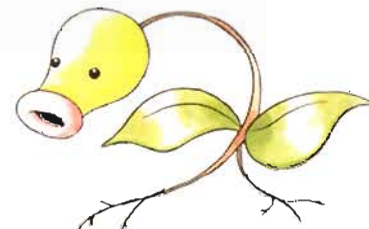
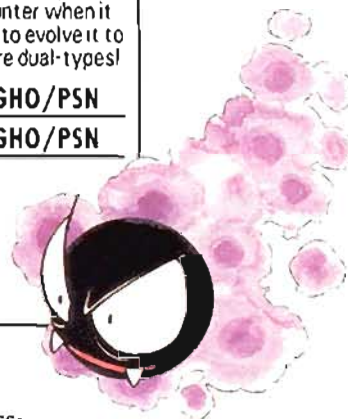

Your Rival thinks the Elder is weak. He's not much of a challenge if you have a Flying- or Fire-type along with you. Don't use a Rock-type unless you want to lose.

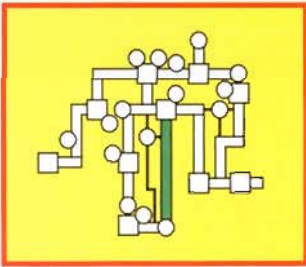

Route 32

Many of the Trainers you'll meet up with on Route 32 will be using Water-type Pokémon, and the caves have lots of wild Rock-types, so it's best to move your Grass-type Pokémon to the top of your party. That way, you'll always have the advantage when a battle begins.

ROUTE 32	GOLD			SILVER		
	MORNING	DAY	NIGHT	MORNING	DAY	NIGHT
#19 RATTATA	MANY	MANY	MANY	FEW	MANY	NONE
#23 EKANS	NONE	NONE	NONE	MANY	MANY	MANY
#41 ZUBAT	FEW	NONE	FEW	FEW	NONE	FEW
#69 BELLSPROUT	MANY	MANY	MANY	MANY	MANY	MANY
#179 MAREEP	MANY	MANY	MANY	MANY	MANY	MANY
#187 HOPPIP	MANY	MANY	NONE	MANY	MANY	NONE
#194 WOOPER	FEW	NONE	MANY	FEW	NONE	MANY

#179 MAREEP TYPE: ELECTRIC

Capture this Electric-type as soon as you can, and raise it well. It is a very helpful Pokémon to have.

LEVEL 15 #180 FLAAFFY ELC
LEVEL 30 #181 AMPHAROS ELC

Attacks

THUNDER WAVE
LIGHT SCREEN
THUNDERPUNCH (#181)
THUNDER

HMs

FLASH
STRENGTH (#180,181)



1 FRIEDA OF FRIDAY POISON BARB

Every Friday, one of the Day siblings, Frieda of Friday, will be standing in the forest, waiting to talk to you. She will present you with Poison Sting, an item that makes a Pokémon's Poison-type attacks stronger.



2 GONE FISHING OLD ROD

Talk to the man closest to the healing machine inside the Pokémon Center. He will offer you one of his fishing poles, the Old Rod. With the Old Rod, you can walk up to water and start fishing for Water-type Pokémon.

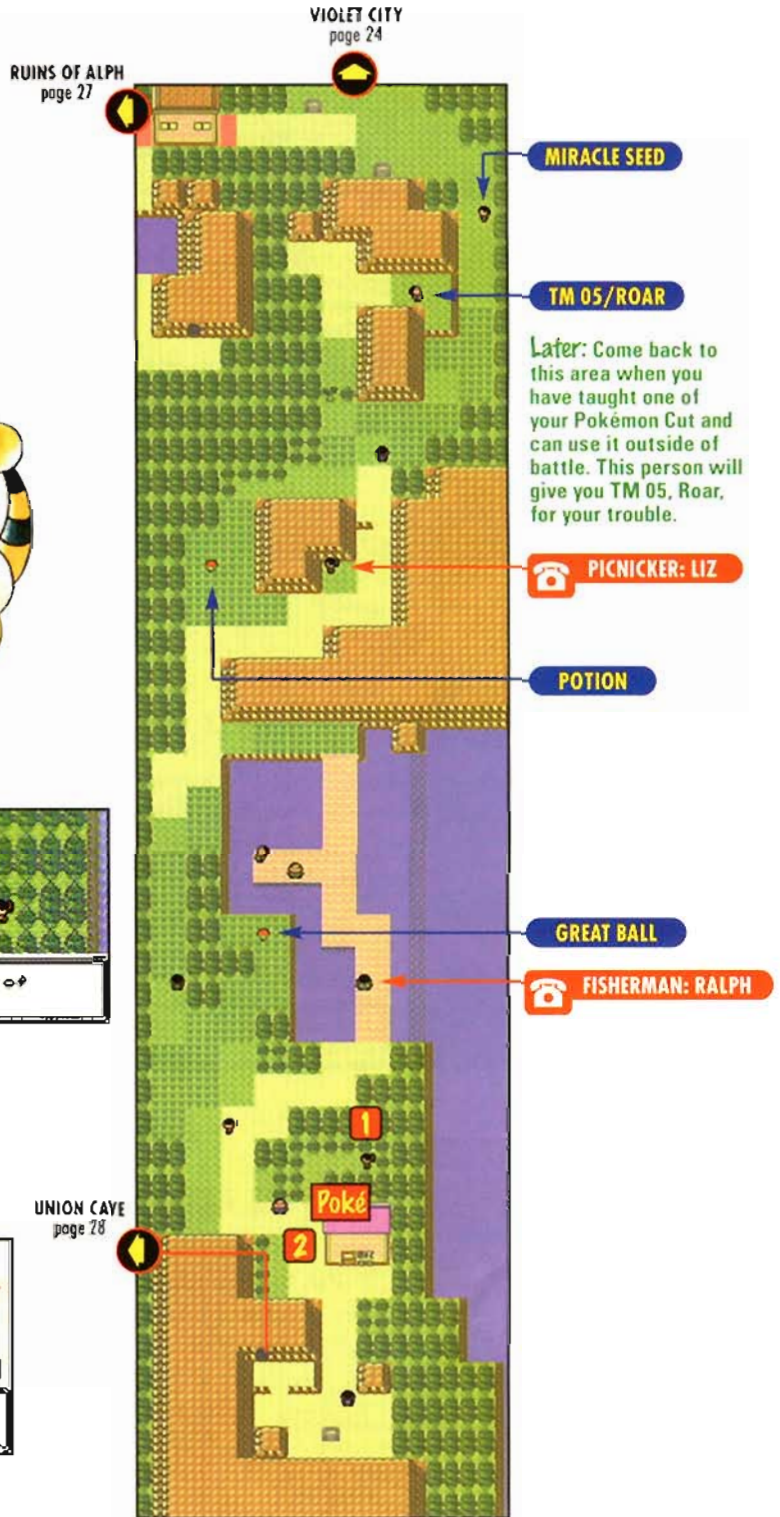

#187 HOPPIP TYPE: GRASS/FLYING

This Grass-and-Flying-type seems to learn more Grass-type attacks than Flying-type attacks. Its Flying-type makes it powerful against Fighting-types.

LEVEL 18 #188 SKIPLOOM GRS/FLY
LEVEL 27 #189 JUMPLUFF GRS/FLY

Attacks
SYNTHESIS
POISONPOWDER
LEECH SEED
MEGA DRAIN

HMs
FLASH

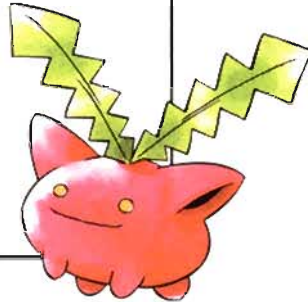

#194 WOOPER TYPE: WATER/GROUND

Wooper's Water-and-Ground-type makes it much stronger against Electric-types than regular Water-types. It also makes it more vulnerable to Grass-types.

LEVEL 20 #195 QUAGSIRE WTR/GRD

Attacks
EARTHQUAKE
RAIN DANCE
MIST
HAZE

HMs
SURF
FLASH
WHIRLPOOL
STRENGTH (#195)

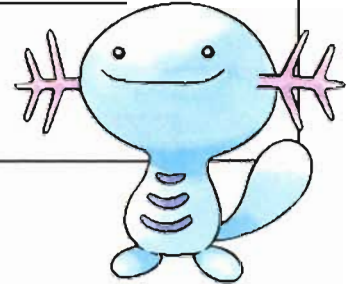

Ruins of Alph

The Ruins of Alph house an interesting Archaeological Site that is over 1,500 years old. It's being studied by scientists trying to unlock its secrets. What could the mysterious writing that covers the walls mean? Until you can use Surf or Strength, you won't be able to explore the entire area to find out.

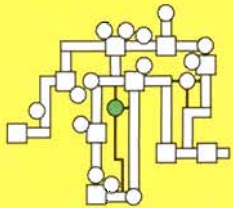

RUINS OF ALPH

GOLD
MORNING DAY NIGHT

SILVER
MORNING DAY NIGHT

#201 UNOWN

MANY MANY MANY MANY MANY MANY

1 THE FIRST PUZZLE ROOM

The room has a puzzle in its center. Read the hint on the right side of the stone tiles to help you slide the pieces into position. Start with the corners, then the border, then finish with the inner pieces. When you solve the puzzle, a hole will open in the floor. Once you've dropped down the hole, the Unown Pokémon will start to appear in the ruins.

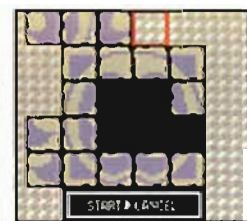

The tiles are very faintly colored, and when they're put together correctly, you'll see a picture of a Kabuto.

2 ALPH LAB

Catch at least three differently shaped Unown and show them to the researchers inside the lab. One will alter your Pokédex so that you can keep track of the Unown that you catch. They will be listed in the order that you catch them in. There are many different types of Unown.



#201 UNOWN
TYPE: PSYCHIC



3 4 5 PUZZLE ROOM

Later: Once you can use Surf, you can return to these caves to solve three more sliding rock puzzles. You can also use Surf and Strength to get to rooms 4 and 5 through Union Cave. Try to solve all four of the puzzles in the puzzle rooms if you can.

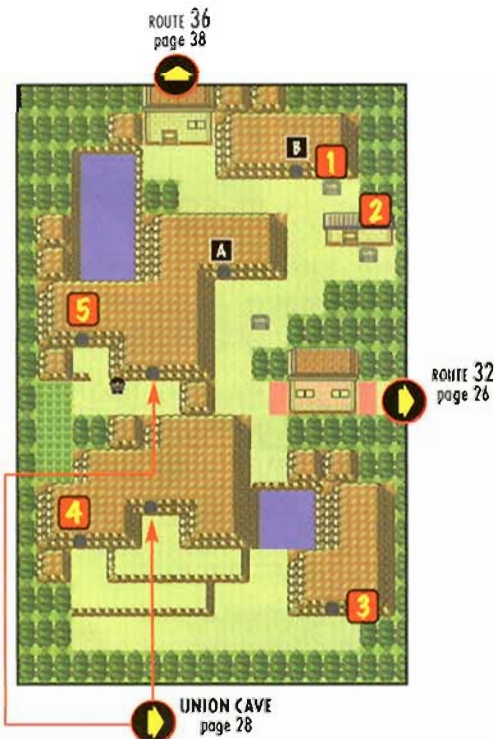

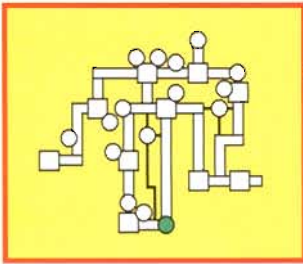

Union Cave

When you first visit Union Cave, you probably won't be able to use Surf and Strength, which you need to use to get around the entire cave. You will be able to explore the first floor and the area marked Basement 1-1. Talk to everyone you see. Some people have very interesting information.

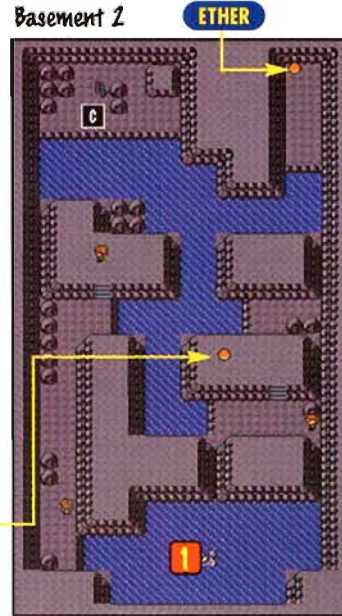
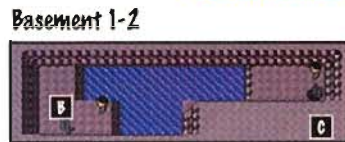
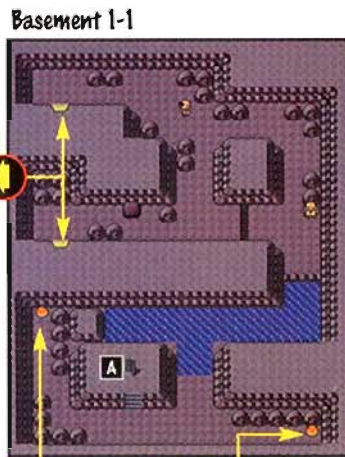
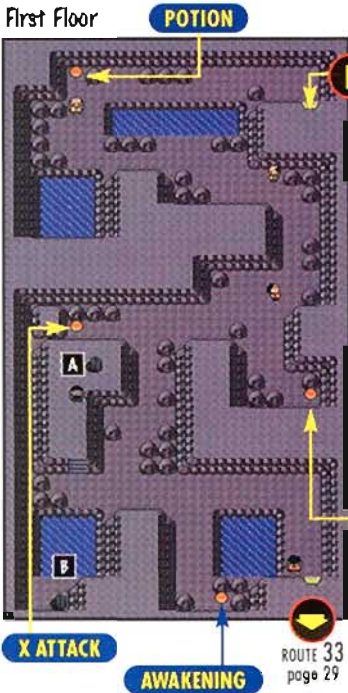

1 LAPRAS

Once you can use Surf, enter the second Basement level of Union Cave on a Friday. It is the only place you will find Lapras, the Water-and-Ice-type. Lapras will continue to appear there, even after you catch it.

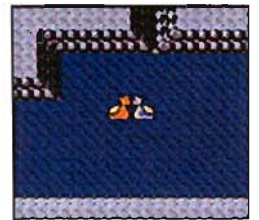

First Floor	GOLD			SILVER		
	MORNING	DAY	NIGHT	MORNING	DAY	NIGHT
#19 RATTATA	MANY	MANY	MANY	MANY	MANY	MANY
#27 SANDSHREW	MANY	MANY	MANY	NONE	NONE	NONE
#41 ZUBAT	MANY	MANY	MANY	MANY	MANY	MANY
#74 GEODUDE	MANY	MANY	MANY	MANY	MANY	MANY
#95 ONIX	FEW	FEW	FEW	FEW	FEW	FEW

Basement 1-1	GOLD			SILVER		
	MORNING	DAY	NIGHT	MORNING	DAY	NIGHT
#19 RATTATA	FEW	FEW	FEW	MANY	MANY	MANY
#27 SANDSHREW	MANY	MANY	MANY	NONE	NONE	NONE
#41 ZUBAT	MANY	MANY	MANY	MANY	MANY	MANY
#74 GEODUDE	MANY	MANY	MANY	MANY	MANY	MANY
#95 ONIX	MANY	MANY	MANY	MANY	MANY	MANY

#131 LAPRAS TYPE: WATER/ICE

Lapras is a very tough Water-and-Ice-type Pokémon that can learn many different types of attacks in addition to the recommended attacks below.

Attacks
MIST
BODY SLAM
ICE BEAM
HYDRO PUMP

HMs
SURF

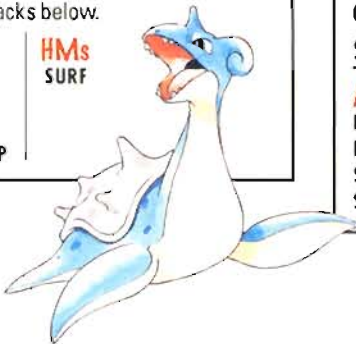

#95 ONIX TYPE: ROCK/GROUND

The dual Rock-and-Ground-type Pokémon Onix does very well with Ground- or Rock-type attacks, or attacks like Slam that use Onix's considerable heft to their advantage.

SEE PG.90 #208 STEELIX GRD/STL

Attacks
BIND
ROCK THROW
SAND STORM
SLAM

HMs
STRENGTH



#41 ZUBAT TYPE: POISON/FLYING

Zubat are quite common in cave-like settings. Their dual Poison-and-Flying-type leaves them vulnerable to a number of attacks, including Ground, Psychic, Bug, Electric, Ice and Rock. They're phenomenal against Grass-types, however.

SEE PG.92 #169 CROBAT PSN/FLY

Attacks
BITE
CONFUSE RAY
WING ATTACK
HAZE

HMs
NONE

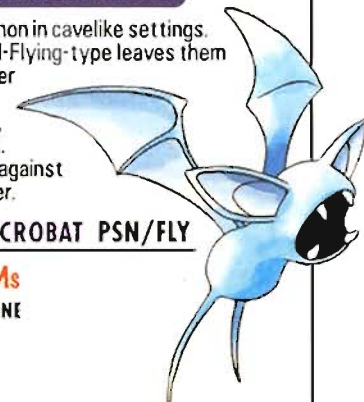

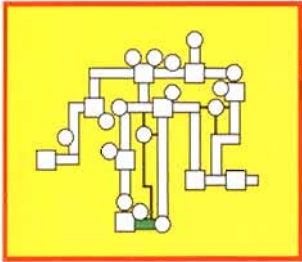

Route 33

Route 33 is extremely short, but there is one Trainer along the way who will want to battle. When you beat the Trainer, he will offer to give you his phone number. Take it to see what he has to tell you later on. Check the tree for a Poisoncure Berry—it will come in handy.

Route 33

	GOLD			SILVER		
	MORNING	DAY	NIGHT	MORNING	DAY	NIGHT

#19 RATATTA	MANY	MANY	MANY	MANY	MANY	MANY
#21 SPEAROW	MANY	MANY	NONE	MANY	MANY	NONE
#23 EKANS	NONE	NONE	NONE	MANY	MANY	MANY
#41 ZUBAT	FEW	NONE	MANY	FEW	NONE	MANY
#187 HOPPIP	MANY	MANY	NONE	MANY	MANY	NONE

HIKER: ANTHONY

AZALEA TOWN
page 29



POISONCURE BERRY

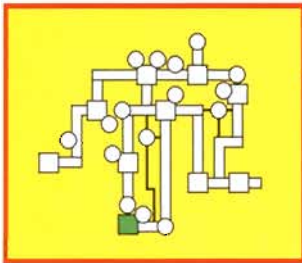

Azalea Town

Many friendly Slowpoke used to roam freely around Azalea Town, but something has made them disappear. It's pretty certain that Team Rocket is behind the disappearance. Hurry over to Kurt's House on the left side of town to get to the bottom of the mystery!

1 KURT'S HOUSE

LURE BALL

When you get to Kurt's House, you learn that he has gone to the Slowpoke Well in search of Team Rocket. Walk back to the Slowpoke Well and help Kurt out. When Team Rocket is finally defeated in town, Kurt will give you the Lure Ball. If you bring Kurt different Apricorns, he will make you different balls.

2 SLOWPOKE WELL

Once you've visited Kurt's House and learned the details of the Slowpoke disappearance, the man who was blocking the well will be gone. Go down into the well to help Kurt defeat Team Rocket and make Azalea Town a safe place for Slowpoke once more.

3 POWER UP

CHARCOAL

After you save the Slowpoke, the man inside the house will tell you that his apprentice is missing. Look for the apprentice in Ilex Forest. When you find him, help him out. See the Ilex Forest section for more information on helping the apprentice.

ILEX FOREST
page 31

WHITE APRICORN

SLOWPOKE WELL
page 30



RIVAL!

After you defeat Team Rocket, your Rival will appear. Your Rival is strong, but if your Pokémon are over Level 16 and healthy, you'll be fine.

Until you have defeated Team Rocket and rescued the Slowpoke, a man will block the entrance to the Azalea Town Gym.

ROUTE 33
page 29

POKÉMON MART

CHARCOAL	9,800
POKé BALL	200
POTION	300
SUPER POTION	700
ESCAPE ROPE	550
REPEL	350
ANTIDOTE	100
PARALYZE HEAL	200
FLOWER MAIL	50



Later: Once you've helped the apprentice with his problem (see the Ilex Forest section, page 31) return to the house to receive Charcoal. Charcoal increases the power of Fire-type attacks.

4 AZALEA TOWN GYM

Once the Slowpoke have been saved and all is well again in Azalea Town, you can enter the Gym and take on its leader. A few Trainers are also inside the Gym. Nearly all of the people inside the Gym use Bug-type Pokémon, so take along Fire- or Flying-types.



AZALEA TOWN GYM LEADER: BUGSY

LEVEL 14	METAPOD	BUG
LEVEL 16	SCYTHYR	BUG/FLY
LEVEL 14	KAKUNA	BUG/PSN

RECOMMENDED POKÉMON TYPES:
FIRE, FLYING, ROCK

Bugsy likes Bug-type Pokémon, which makes your job much easier. Use Fire-, Flying- or Rock-types to squash Bugsy. When you defeat him, he will award you with the Hive Badge and TM 49, Fury Cutter. Fury Cutter's attack power doubles when it's used continuously.

PRIZES: HIVE BADGE/TM 49 (FURY CUTTER)

The Hive Badge will give you the power to control Pokémon up to Level 30, and allow you to use Cut outside of battle.

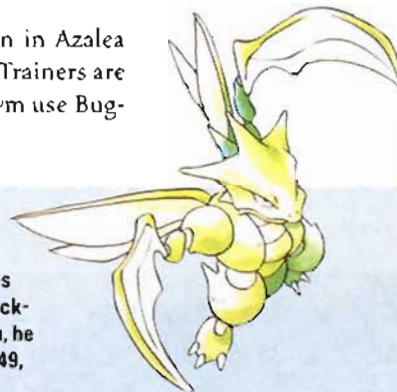

RIVAL! BATTLE 2



LEVEL 16	CROCONAW	WTR
LEVEL 16	BAYLEEF	GRS
LEVEL 16	QUILAVA	FIR
AND		
LEVEL 12	GASTLY	GHO/PSN
LEVEL 14	ZUBAT	PSN/FLY

Once again, your Rival will have whichever starting Pokémon your starting Pokémon is weak against. A strong Electric-type could deal with many of your Rival's Pokémon nicely, especially if your Rival has a Croconaw. If your Pokémon are over Level 16 and are completely healthy, you should be able to outlast Rival.

RECOMMENDED POKÉMON TYPES:
ELECTRIC, FIRE, GRASS, WATER

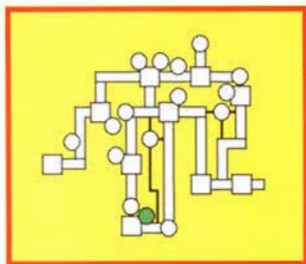
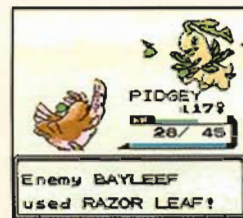

Slowpoke Well

You'll see Kurt as soon as you enter the well. He's hurt his back and can't continue, so you must take on Team Rocket alone. You won't be able to explore the well completely until you know Surf and Strength, so you'll need to return to the area later.



Later: Surf to the area marked A on Basement 1 to reach Basement 2. There you will talk to the researcher, who will give you the King's Rock. You can also Surf to the other side, and pick up TM 18, Rain Dance.

AZALEA TOWN
page 29



KING'S ROCK

Basement 1

	GOLD			SILVER		
	MORNING	DAY	NIGHT	MORNING	DAY	NIGHT

#41 ZUBAT	MANY	MANY	MANY	MANY	MANY	MANY
#79 SLOWPOKE	MANY	MANY	MANY	MANY	MANY	MANY

Basement 2

	GOLD			SILVER		
	MORNING	DAY	NIGHT	MORNING	DAY	NIGHT

#41 ZUBAT	MANY	MANY	MANY	MANY	MANY	MANY
#42 GOLBAT	FEW	FEW	FEW	FEW	FEW	FEW
#79 SLOWPOKE	MANY	MANY	MANY	MANY	MANY	MANY
#80 SLOWBRO	MANY	MANY	MANY	MANY	MANY	MANY

#79 SLOWPOKE TYPE: WATER/PSYCHIC

This slow creature is an interesting mix of both Water- and Psychic-types, making it a good pick to battle many types of Pokémon. What could the King's Rock possibly do?

LEVEL 37 #80 SLOWBRO WTR/PSY
SEE PG. 90 #199 SLOWKING WTR/PSY

Attacks	HMs
CURSE	SURF
READBUTT	STRENGTH
AMNESIA	FLASH
PSYCHIC	



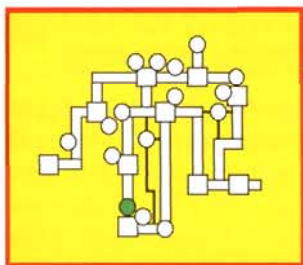

Ilex Forest

The dark, gloomy forest is very large and confusing. After you help the Apprentice, you can explore the forest to find TM 02, Headbutt, which can shake Pokémon out of trees. The girl in the guard house will give you TM 12, Sweet Scent, which can attract more Pokémon to you.

Ilex Forrest	GOLD			SILVER		
	MORNING	DAY	NIGHT	MORNING	DAY	NIGHT
#10 CATERPIE	MANY	MANY	NONE	NONE	NONE	NONE
#11 METAPOD	MANY	MANY	NONE	NONE	NONE	NONE
#14 KAKUNA	NONE	NONE	NONE	MANY	MANY	NONE
#13 WEEDLE	NONE	NONE	NONE	MANY	MANY	NONE
#41 ZUBAT	FEW	FEW	MANY	FEW	FEW	MANY
#43 ODDISH	NONE	NONE	MANY	NONE	NONE	MANY
#46 PARAS	MANY	FEW	MANY	MANY	FEW	MANY

1 FARFETCH'D ON THE RUN

Farfetch'd is in the middle of the forest. Chase it in the box pattern shown on the map to the right, then chase it back up to the Charcoal Maker's Apprentice. The Charcoal Maker will give you HM 01, Cut! Use Cut to remove the tree at the top of the path that is blocking your way up to Route 34. If you go back to Azalea Town to the Charcoal Maker's House, the Apprentice will give you Charcoal.

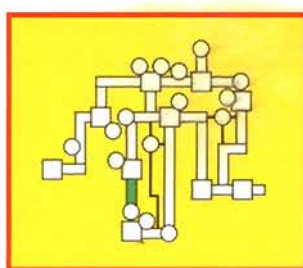
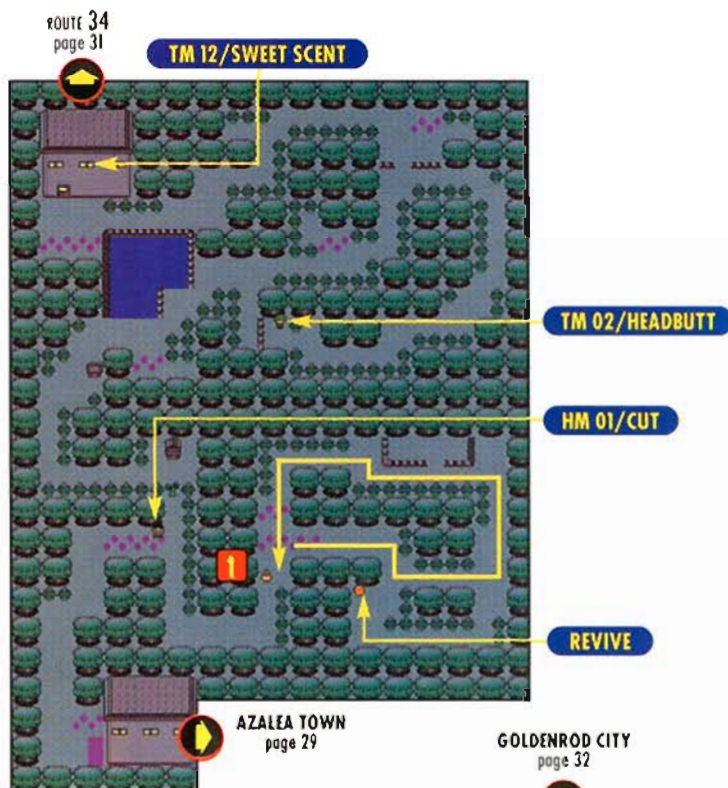

Route 34

Route 34 falls between Ilex Forest and Goldenrod City. Near the top of the path is the Pokémon Daycare. You won't be able to get Soft Sand until you can Surf over to the three girls at the bottom left of Route 34.

Route 34	GOLD			SILVER		
	MORNING	DAY	NIGHT	MORNING	DAY	NIGHT
#19 RATTATA	MANY	MANY	MANY	MANY	MANY	MANY
#63 ABRA	MANY	MANY	MANY	MANY	MANY	MANY
#96 DROWZEE	MANY	MANY	MANY	MANY	MANY	MANY
#132 DITTO	FEW	FEW	FEW	FEW	FEW	FEW

1 POKÉMON DAYCARE

You can leave up to two Pokémon in the care of the Daycare Man and Lady. If you leave two of different genders with the couple, you might get a Pokémon Egg! You can also try leaving Ditto and any other Pokémon with the couple.



CAMPER: TODD

Night

The guard stands watch all day long, but he won't challenge you to a battle until night falls.

PICNICKER: GINA

Later: Your Pokémon will gain levels, learn new moves and maybe even produce eggs if you leave them at the Pokémon Daycare. Return to the Daycare a few hours after you drop off a pair to see if an egg has appeared.

SOFT SAND



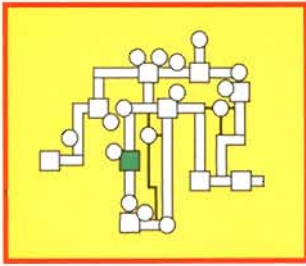

Goldenrod City

Route 34 leads to a large city that has a Radio Tower, a Bike Shop and a huge Department Store. There are many things to see and do there—make sure you’ve accomplished them all before you head off to the next city or route. Team Rocket is skulking around the city.

1 RADIO TOWER

Many popular Radio Shows are broadcast from the Radio Tower, including Pokémon Talk with Professor Oak and DJ Mary. The station is having a contest. Talk to the third person behind the counter to enter it. Maybe you’ll win a prize!



Once you get the Radio Card, you can listen to many radio programs, including the Lucky Channel. The program broadcasts one number a week. If your Pokémon match that ID number, you win.

Later: Trade with as many Trainers as possible during your journey to acquire Pokémon with several different ID numbers. Each week, the Lucky Channel selects a different number, so tune in to channel 8.5 regularly. If you do have a matching number, go to the Radio Tower to claim a prize.

2 BIKE SHOP BICYCLE

When you wander into the Bike Shop, the owner will ask you to ride around on one of his bikes to show everyone how much fun it is. You can move much faster with the bike.



You can register the bike by highlighting it in your Pack, then choosing SEL from the menu. After that, just hit Select when you want to ride.

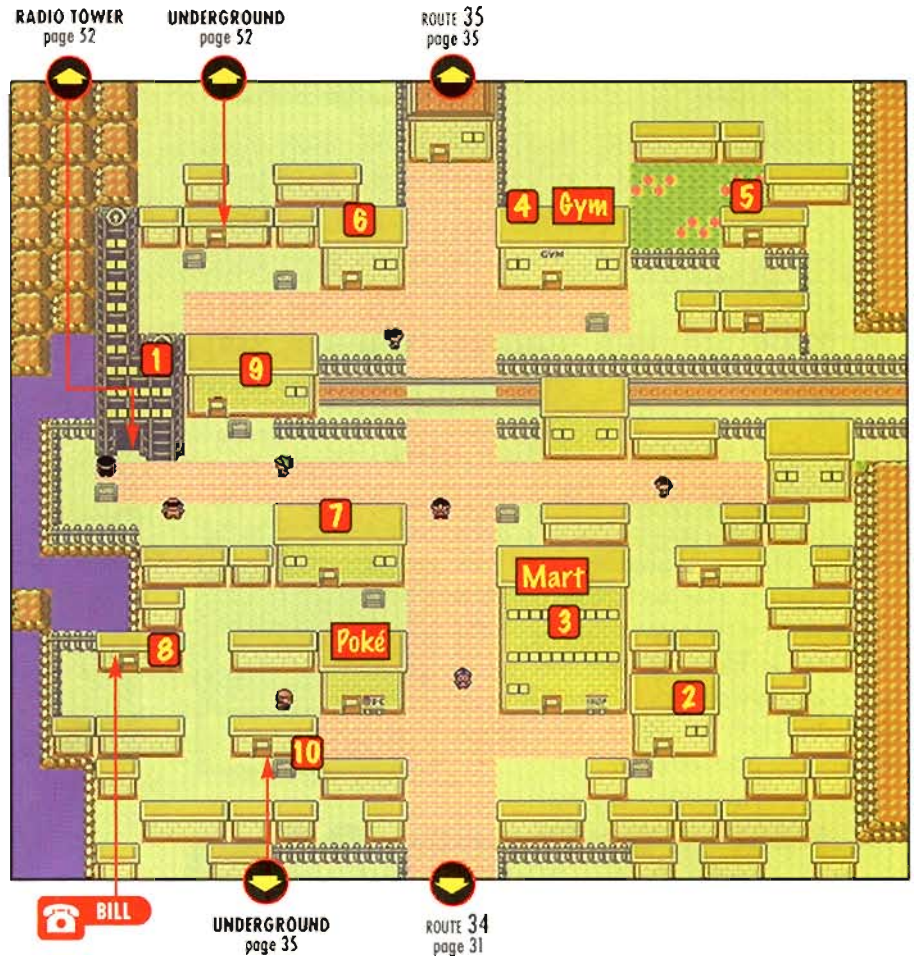

POKéMON MART

2 nd Floor-1	
POTION	300
SUPER POTION	700
ANTIDOTE	100
PARALYZE HEAL	200
AWAKENING	250
BURN HEAL	250
ICE HEAL	250

2 nd Floor-2	
POKé BALL	200
GREAT BALL	600
ESCAPE ROPE	550
REPEL	350
REVIVE	1,500
FULL HEAL	600
POKé DOLL	1,000
FLOWER MAIL	50

3 rd Floor	
X SPEED	350
X SPECIAL	350
X DEFEND	550
X ATTACK	500
DIRE HIT	650
GUARD SPEC.	700
X ACCURACY	950

4 th Floor	
PROTEIN	9,800
IRON	9,800
CARBOS	9,800
CALCIUM	9,800
HP UP	9,800
6 th Floor	
FRESH WATER	200
SODA POP	300
LEMONADE	350

5 th Floor	
TM 41/THUNDERPUNCH	3,000
TM 48/FIRE PUNCH	3,000
TM 33/ICE PUNCH	3,000
TM 02/HEADBUTT*	2,000
TM 08/ROCK SMASH**	1,000

* TM 02 won't be available for purchase until you've already received it in Ilex Forest.
** TM 08 won't be available for purchase until you've already obtained it on Route 36.

3 DEPARTMENT STORE

GOLD BERRY **TM 21/FRUSTRATION** **TM 27/RETURN**

You do more than just buy things in the Goldenrod City Department Store! Talk to everyone inside the store for interesting information, including news of a woman who visits the store every Sunday and hands out TMs to Trainers. If your lead Pokémon likes you a lot, the woman will give you TM 27, Return. If not, you will get TM 21, Frustration. A boy on the fifth floor wants to trade a Drowzee for a Machop. It's holding a Gold Berry, which can restore 30 HP to a Pokémon.



GOLDENROD CITY GYM LEADER: WHITNEY

LEVEL 18 CLEFAIRY **NRM**
LEVEL 20 MILTANK **NRM**

Whitney has only two Pokémon, but they're pretty powerful Normal-type Pokémon. If you've managed to train a Fighting-type of your own, you'll do well. Miltank uses an attack called Rollout that increases in power each turn. Try to take Miltank out quickly before Rollout takes you out.

PRIZES: PLAIN BADGE/TM 45 (ATTRACT)

After you beat Whitney, you'll be able to use Strength outside of battle. You will also win TM 45, Attract.

RECOMMENDED POKÉMON TYPES:
FIGHTING, ROCK



5 TREE RELIEF

SQUIRTBOTTLE

The woman inside the house will give you information about the living tree blocking the way to Route 36. After you beat Whitney, the Goldenrod City Gym Leader, go back to the house. The woman will give you the Squirtbottle to use to bother the tree.



6 PET NAMES

A name rater lives in Goldenrod City. He will rate the name of the Pokémon that is first in your party. He will give you the option of changing that Pokémon's name. You can use the Name Rater to change the names of all your Pokémon except those you received in trade.



7 LET THE GAMES BEGIN

The Goldenrod City Game Corner has two games of chance for you to play. Both are pretty difficult but very fun. You can't play the games until you've picked up the Coin Case in Goldenrod City's Underground Path. Exchange some of your money for coins—then you can play at any of the game machines. If you win big, you'll be able to exchange your coins for the prizes shown at the right.



	CHERRY		STARYU!
6		15	
	PIKACHU		POKé BALL
8		50	
	SQUIRTLE		777
10		300	



PRIZE

TM 25/THUNDER	5,500
TM 14/BLIZZARD	5,500
TM 38/FIRE BLAST	5,500
#63 ABRA	200
#24 EKANS (GOLD)	700
#27 SANDSHREW (SILVER)	700
#147 DRATINI	2,100

GAME 1

Stop the three revolving wheels on the Slot Machine one at a time with the A Button. If you bet three coins, you can win with any horizontal or diagonal line of three identical symbols. Bet two coins—any horizontal row wins. If you bet one coin, the three middle symbols have to match. Each symbol's payoff is shown above.

GAME 2

Guess which of the 24 cards has been dealt on the left in this Card Guessing Game. You have 12 tries per game, and you must bet three coins. You pick one randomly generated card with A, and it is placed on the left. Next, you choose a vertical row, a single or double horizontal row or a single card. The fewer cards you bet on, the higher the payoff. Try choosing rows at first, then, as more cards are eliminated, move to single cards. After 12 cards are eliminated, the deck is reshuffled and the game starts over.

8 BILL'S HOUSE

Bill is not home, but his mom and sister are. Bill's sister will give you his number, which you can use to see how full your current storage box on Bill's PC is. Bill will call you when you fill up your box. After you meet Bill in person, return to this house for a special treat.



Later: After you've met up with Bill in Ecruteak City, go back to his house in Goldenrod, where you will receive Eevee.

#133 EEEVEE TYPE: NORMAL

Eevee is the only Pokémon that can evolve into five different types of creatures. After you get Eevee from Bill, you might want to breed five extra Eevee to evolve into the five creatures listed below. A party of the six Eevee variations would be a pretty good team to take with you!

Attacks
SAND ATTACK
QUICK ATTACK
BITE
TAKE DOWN

HMs
NONE

WATER STONE	#134 VAPOREON	WTR
THUNDER STONE	#135 JOLTEON	ELC
FIRE STONE	#136 FLAREON	FIR
SEE PG.92	#196 ESPEON	PSY
SEE PG.92	#197 UMBREON	DRK

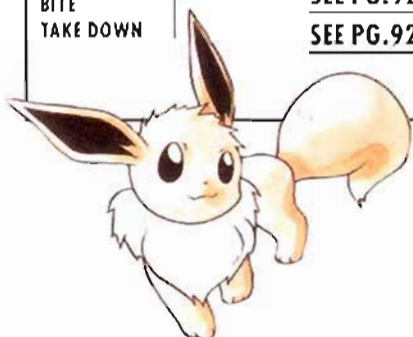

#134 VAPOREON TYPE: WATER

Vaporeon uses both Water- and Ice-type attacks very well. It is a thick-skinned creature that can take a lot of damage before it falters, especially if you equip it with Acid Armor.

Attacks
AURORA BEAM
HAZE
ACID ARMOR
HYDRO PUMP

HMs
SURF
WHIRLPOOL
WATERFALL



#135 JOLTEON TYPE: ELECTRIC

Jolteon is often used against Psychic-types because it can learn the Bug-type attack Pin Missile. Jolteon is extremely fast, making it a good choice for your starting Pokémon.

Attacks
DOUBLE KICK
PIN MISSILE
THUNDER WAVE
THUNDER

HMs
FLASH

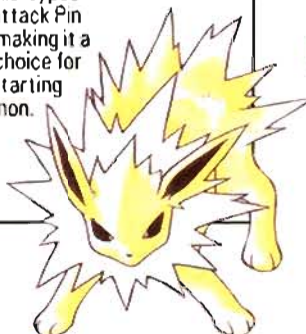

#136 FLAREON TYPE: FIRE

The fiery member of the Eevee family is no slouch, and it also benefits from a well-rounded range of attacks. A powerful Fire-type attack such as Flamethrower gives this Pokémon some much-needed heat.

Attacks
SAND-ATTACK
QUICK ATTACK
BITE
FLAMETHROWER

HMs
NONE



#197 UMBREON TYPE: DARK

Like all Dark-types Umbreon is strong against Psychic types. You might want to raise your Eevee into an Umbreon so you can have a Dark-type.

Attacks
PURSUIT
QUICK ATTACK
FAINT ATTACK
MOON LIGHT

HMs
FLASH



#196 ESPEON TYPE: PSYCHIC

Espeon is a Psychic-type, and no Psychic-type Pokémon is truly complete unless it's using Psychic, one of the most powerful attacks in the game. An Espeon with a well-rounded roster of attacks would be very helpful.

Attacks
SAND-ATTACK
BITE
PSYCHIC
MORNING SUN

HMs
FLASH



Later: After you have fixed the problem at the Power Station in Kanto, you will need to get a Railway Pass in Saffron City. The train runs anytime you want to ride it, and it makes traveling between Johto and Kanto very easy.

9 GOLDENROD CITY STATION



The Goldenrod City Station is a train station. The train won't be coming in for a long while, although you won't know that right away. When the Magnet Train finally does start to run, you will be able to take it to Saffron City in Kanto. But you have to fix the train's power supply and find a ticket in Kanto, and that is still a long way off.



10 UNDERGROUND

The Underground is a tunnel that connects several areas of Goldenrod City together. There are shops you can visit on different days in the Underground, so be sure to stop back often to try out the services they have to offer. Details about the Underground are located in the Radio Tower and Underground section on page 52.

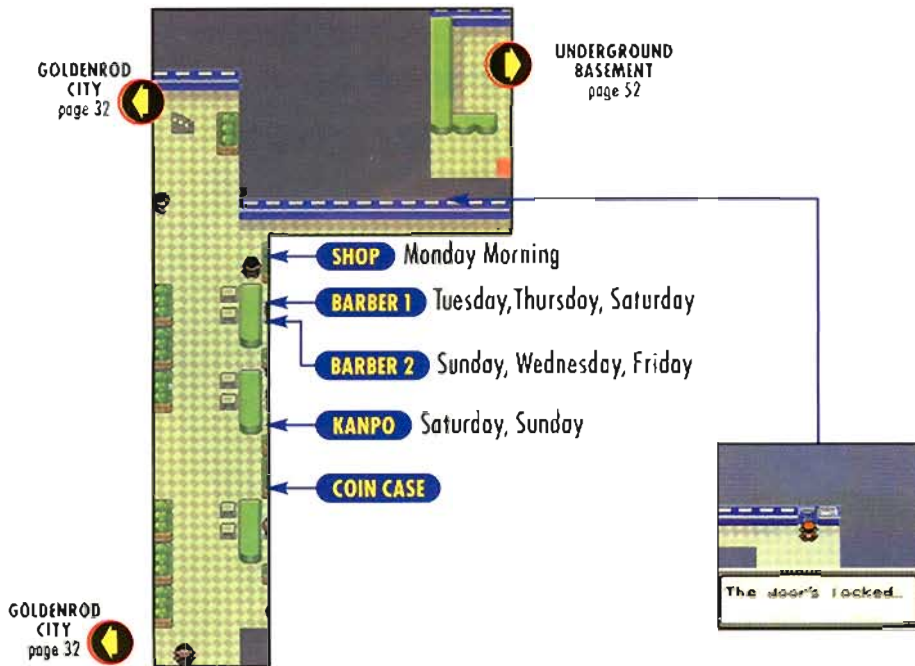

BARBER 1 AND BARBER 2
The Haircut Brothers are in residence on different days. Both will cut only one of your Pokémon's hair a day, so choose wisely. Pokémon are happier and friendlier after a haircut.

NUGGET	4,500
PEARL	650
BIG PEARL	3,500
STARDUST	900
STAR PIECE	4,600

ENERGY POWDER	500
ENERGY ROOT	800
HEAL POWDER	450
REVIVAL HERB	2,800

SHOP
The Bargain Shop is open on Monday mornings. All of its items are dirt cheap. Even if you don't need them, you can buy one of each and sell them to another shop and make a little profit. Not bad!

KANPO
Kanpo sells medicine at low prices, but they're bitter and your Pokémon won't like them much. Maybe the potions aren't a very good bargain. You can do better.

Later: A door is locked the first time you come to it, but after you've made it to the top of the Radio Tower you will get a Key Card that lets you into the locked section of the Underground.

Route 35

Route 35 leads to the National Park. If you Cut the tree on the upper right, you'll gain access to Route 36. The Trainers there have lots of different Pokémon, so you'd better have lots of different Pokémon, too.

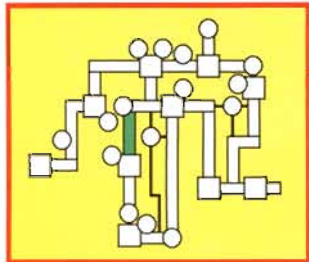

Route 35

	GOLD			SILVER		
	MORNING	DAY	NIGHT	MORNING	DAY	NIGHT
#16 PIDGEY	FEW	FEW	NONE	FEW	FEW	NONE
#29 NIDORAN ♀	MANY	MANY	MANY	MANY	MANY	MANY
#32 NIDORAN ♂	MANY	MANY	MANY	MANY	MANY	MANY
#63 ABRA	MANY	MANY	MANY	MANY	MANY	MANY
#96 DROWZEE	MANY	MANY	MANY	MANY	MANY	MANY
#132 DITTO	FEW	FEW	FEW	FEW	FEW	FEW
#163 HOOTHOOT	NONE	NONE	FEW	NONE	NONE	FEW
#193 YANMA	FEW	FEW	FEW	FEW	FEW	FEW

1 SPECIAL DELIVERY HP UP

Talk to the guard in the southernmost guard house. He will ask you to take a Pokémon that's holding mail to his friend on Route 31. After you finish the errand, come back to the guard house. The guard will give you HP UP.

This officer won't bug you during the day, but if you pass him at night, he'll challenge you to a battle. He's not a big challenge.

NATIONAL PARK page 36

ROUTE 36 page 37

NIGHT

JUGGLER: IRWIN

TM 04/ROLLOUT

BUG CATCHER: ARNIE

MYSTERYBERRY

Later: You won't be able to reach the Mysteryberry just yet, but once you can use Surf outside of battle, Surf over the water to pick up a Mysteryberry.

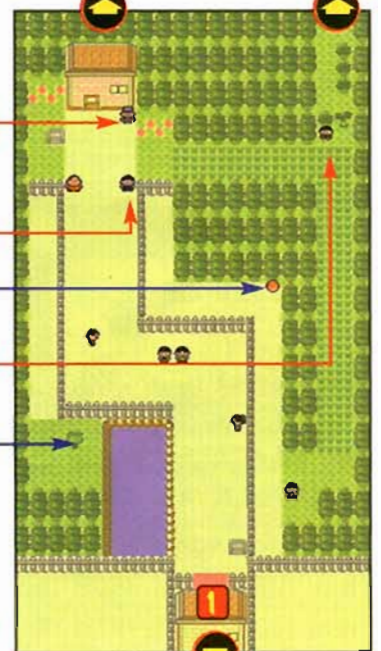

GOLDENROD CITY page 32

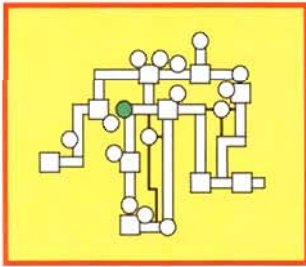

National Park

The pretty park is filled with tall grass and trees. There are several Trainers to battle and chat with, and they've brought along Bug-, Grass- and Rock-type Pokémon.

You might not notice that there's a gap in the fence, but there is one next to the kid on the upper right. Go through the gap to get the items beyond the fence.

1 BUG-CATCHING EVENT

Every Tuesday, Thursday and Saturday, a Bug-Catching Contest is held in National Park. Players compete to win very nice items, like the Sun Stone, the Everstone and the Gold Berry. Every person who enters wins something, even if it's just the consolation Berry. The bugs that you catch will be entered into your Pokédex, but you can keep only one bug. You can take one Pokémon only into the park with you to help. Use a Pokémon that can paralyze, put to sleep or otherwise stun other Pokémon to make them easier to catch. National Park is the only place to catch some Pokémon, so don't miss out.

SCHOOLBOY: JACK

POKéFAN: BEVERLY

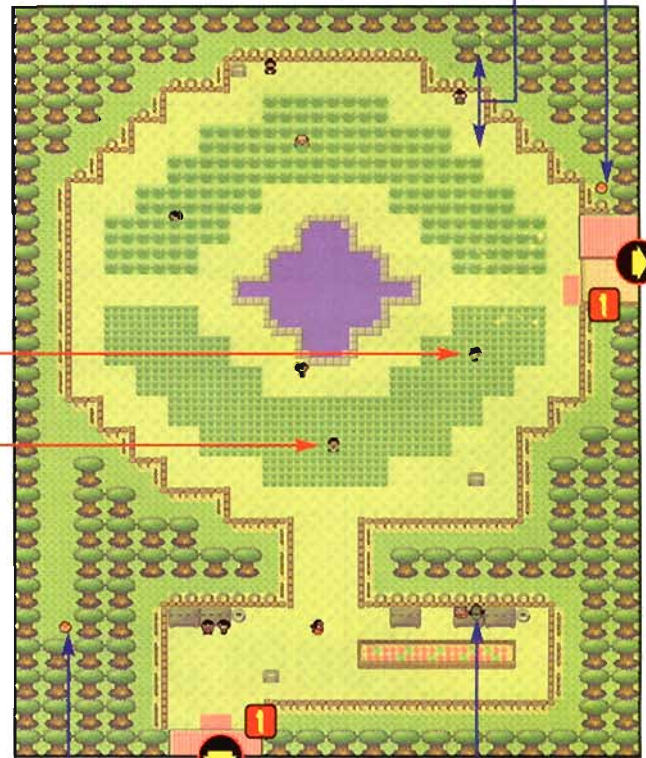

ROUTE 36
page 37

TM 28/DIG

ROUTE 35
page 35

QUICK CLAW

BUG-CATCHING EVENT

#10	CATERPIE	LEVEL 7-18
#11	METAPOD	LEVEL 9-18
#12	BUTTERFREE	LEVEL 12-15
#13	WEEDLE	LEVEL 7-18
#14	KAKUNA	LEVEL 9-18
#15	BEEDRILL	LEVEL 12-15
#46	PARAS	LEVEL 10-17
#48	VENONAT	LEVEL 10-16
#123	SCYTHER	LEVEL 13-14
#127	PINSIR	LEVEL 13-14

The Bug-types that show up are random, so just do your best. Pinsir, Butterfree and Beedrill are good Pokémon to catch.

PRIZE

1 ST	SUN STONE
2 ND	EVERSTONE
3 RD	GOLD BERRY
CONSOLATION	BERRY



You get 20 Parkballs and 20 minutes to catch the toughest Bug-type Pokémon you can find. The contest is over when you run out of Parkballs or time.

National Park

	GOLD			SILVER		
	MORNING	DAY	NIGHT	MORNING	DAY	NIGHT

#10	CATERPIE	MANY	MANY	NONE	NONE	NONE	NONE	NONE	NONE
#11	METAPOD	MANY	MANY	NONE	NONE	NONE	NONE	NONE	NONE
#13	WEEDLE	NONE	NONE	NONE	MANY	MANY	NONE	NONE	NONE
#14	KAKUNA	NONE	NONE	NONE	MANY	MANY	NONE	NONE	NONE
#16	PIDGEY	MANY	MANY	NONE	MANY	MANY	NONE	NONE	NONE
#163	HOOTHOOT	NONE	NONE	MANY	NONE	NONE	MANY	NONE	NONE
#191	SUNKERN	NONE	MANY	NONE	NONE	MANY	NONE	NONE	NONE



#191 SUNKERN TYPE: GRASS

SUN STONE #192 SUNFLORA GRS

Attacks	HMs
GROWTH	CUT
SUNNY DAY	FLASH
SYNTHESIS	
GIGA DRAIN	

Route 36 & Route 37

The next two roads are short, but they lead in many directions and join several areas together. The tree you couldn't get past is still there, but this time you have the Squirtbottle from Goldenrod City. When the tree is gone, you'll finally be able to move on to the next area.

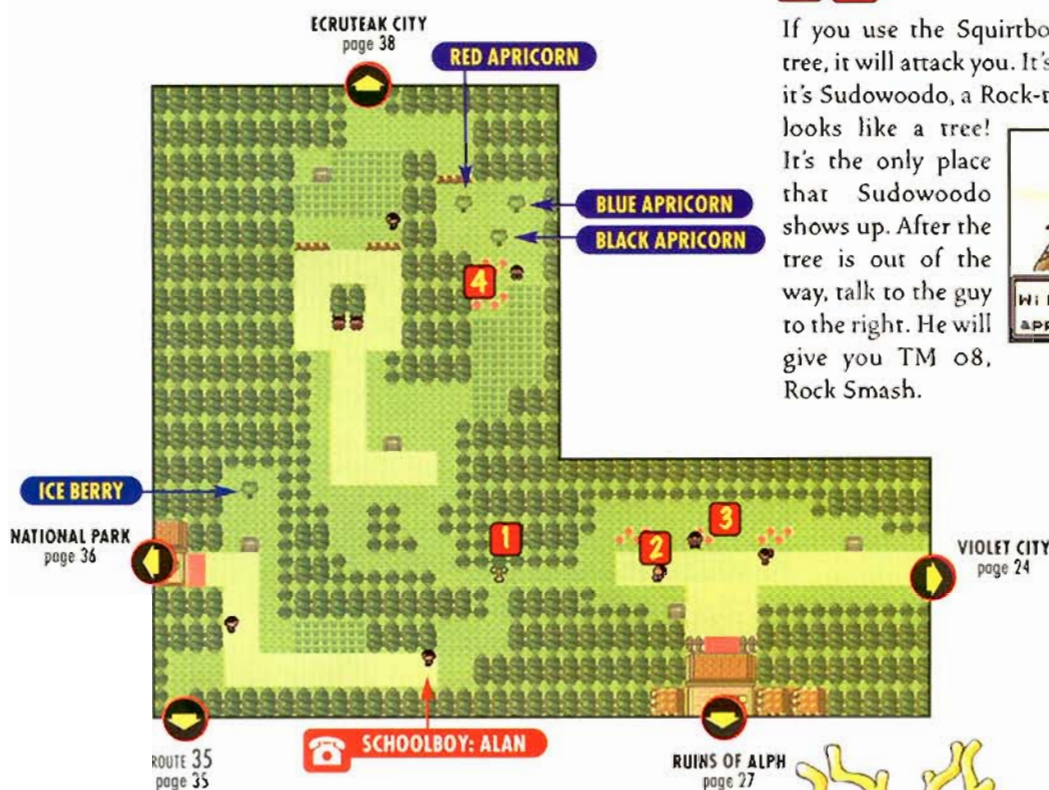
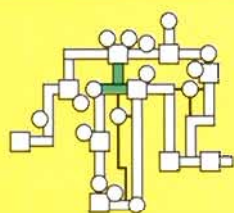

1 2 WEIRD TREE TM 08/ROCK SMASH

If you use the Squirtbottle on the weird tree, it will attack you. It's not a tree at all—it's Sudowoodo, a Rock-type Pokémon that looks like a tree! It's the only place that Sudowoodo shows up. After the tree is out of the way, talk to the guy to the right. He will give you TM 08, Rock Smash.



3 THE DAY BROTHERS 4 HARD STONE MAGNET

Every Thursday, Arthur (3) will be waiting to give you Hard Stone, which increases the power of Rock-type attacks. On Sunday, Sunny (4) will give you Magnet, which increases the power of Electric-type attacks.

Route 37

	GOLD			SILVER		
	MORNING	DAY	NIGHT	MORNING	DAY	NIGHT

#16 PIDGEY	MANY	MANY	NONE	MANY	MANY	NONE
#17 PIDGEOTTO	NONE	FEW	NONE	NONE	FEW	NONE
#37 VULPIX	NONE	NONE	NONE	MANY	MANY	MANY
#58 GROWLITHE	MANY	MANY	MANY	NONE	NONE	NONE
#163 HOOTHOOT	NONE	NONE	MANY	NONE	NONE	MANY
#165 LEDYBA	NONE	NONE	NONE	MANY	NONE	NONE
#167 SPINARAK	NONE	NONE	MANY	NONE	NONE	NONE
#234 STANTLER	MANY	MANY	MANY	MANY	MANY	MANY



#234 STANTLER TYPE: NORMAL

Stantler's regal antlers can confuse and disorient anyone that stares at them too long. Not surprisingly, Stantler can learn attacks like Hypnosis and Confuse Ray. You can also equip Stantler with moves like Take Down and Stomp.

Attacks	HMs
HYPNOSIS	FLASH
STOMP	
TAKE DOWN	
CONFUSE RAY	

#185 SUDOWOODO TYPE: ROCK

Sudowoodo reacts to the water from the Squirtbottle because it's a Rock-type, which is weak against water. Sudowoodo is very rare. Try to add it to your collection!

Attacks

MIMIC
LOW KICK
ROCK SLIDE
FAINT ATTACK

HMs
STRENGTH

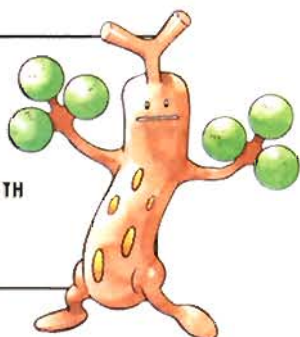

Route 36

	GOLD			SILVER		
	MORNING	DAY	NIGHT	MORNING	DAY	NIGHT

#16 PIDGEY	MANY	MANY	NONE	MANY	MANY	NONE
#29 NIDORAN ♀	MANY	MANY	MANY	MANY	MANY	MANY
#32 NIDORAN ♂	MANY	MANY	MANY	MANY	MANY	MANY
#37 VULPIX	NONE	NONE	NONE	MANY	MANY	MANY
#58 GROWLITHE	MANY	MANY	MANY	NONE	NONE	NONE
#163 HOOTHOOT	NONE	NONE	MANY	NONE	NONE	MANY
#234 STANTLER	FEW	FEW	FEW	FEW	FEW	FEW

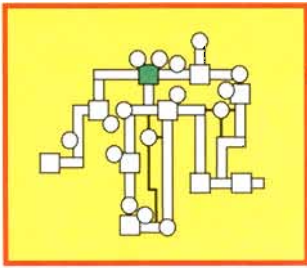

Ecruteak City

Ecruteak City once had two towers, but one burned down in a mysterious fire. There is a story that says the remaining structure, the Tin Tower, is visited by a Legendary Pokémon. You will meet Bill, whose PC storage system you use to keep your Pokémon safe, in Ecruteak.

1 THE KIMONO GIRLS

HM 03/SURF

The five Kimono Girls battle with the five evolutions of Eevee. If you defeat them all, the old man will give you HM 03, Surf, an item you will need to continue your journey. The Kimono Girls are very good Trainers, and their Eevee evolutions are very tough.



You don't have to take on all five Kimono Girls at once. Heal your Pokémon after each battle.

2 BILL AND THE TIME CAPSULE

You will run into Bill in the Pokémon Center. He's fixing the Time Capsule. The day after you talk to Bill, you can use the Time Capsule to trade Pokémon from and to the Red, Blue and Yellow Pokémon games. After you meet Bill, return to his house in Goldenrod to get Eevee.



3 BURNED TOWER

Make sure you heal your Pokémon before you enter the Burned Tower. Just before you enter the Tower, you will meet up with your Rival, who has a much bigger team of Pokémon to challenge you with.



ITEM FINDER

Talk to the man in this house and answer his question. He will give you the Item Finder, which beeps when you are near a hidden item

ROUTE 37
page 37

POKéMON MART

POKéBALL	200
GREAT BALL	600
POTION	300
SUPER POTION	700
ANTIDOTE	100
PARALYZE HEAL	200
AWAKENING	250
BURN HEAL	250
ICE HEAL	250
REVIVE	1,500

4 TIN TOWER

You won't be able to enter the Tin Tower until you have the Fog Badge from Ecruteak's Gym. You also need the Rainbow Wing, which you get in two different ways. Check the section about the Tin Tower on page 40 for more details.



5 ECRUTEAK CITY GYM

The floor will knock you back to the start unless you follow the path marked in yellow to make it to the Gym Trainers and Leader. Many of the Pokémon are using a new attack, Mean Look, which makes it impossible for you to switch your active Pokémon, so try to defeat the Trainers quickly before you're trapped!





ECRUTEAK CITY GYM LEADER: MORTY

LEVEL 21	GASTLY	GHO/PSN
LEVEL 21	HAUNTER	GHO/PSN
LEVEL 25	GENGAR	GHO/PSN
LEVEL 23	HAUNTER	GHO/PSN

RECOMMENDED POKÉMON TYPES:
GROUND, PSYCHIC

Like all of the Trainers in the Gym, Morty uses Ghost-types exclusively. He has one Gastly, two Haunter and one Gengar. They're all very weak against Psychic- or Ground-type attacks, which makes your Pokémon selection process pretty easy.

PRIZES: FOG BADGE/TM 30 (SHADOW BALL)

The Fog Badge allows you to use Surf outside of battle, which is crucial at this stage.

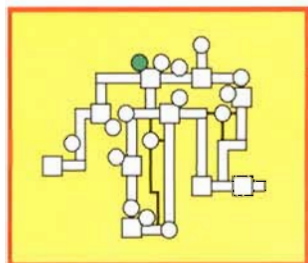

Burned Tower

You will use Rock Smash inside the Burned Tower, so teach a Pokémon the move before you take on the tower. You also have to fall down the holes in the floor to pick up every item in the tower.

RARE CREATURES

When you drop down into the basement from the hole in the middle of the floor, you will see three Pokémon—but they will quickly run away. They are Raikou, Entei and Suicune, and they will wander around Johto randomly. Try to catch them!



FIRST FLOOR

First Floor

	GOLD			SILVER		
	MORNING	DAY	NIGHT	MORNING	DAY	NIGHT
#19 RATTATA	MANY	MANY	MANY	MANY	MANY	MANY
#20 RATICATE	FEW	FEW	FEW	FEW	FEW	FEW
#41 ZUBAT	MANY	MANY	MANY	MANY	MANY	MANY
#109 KOFFING	MANY	MANY	MANY	MANY	MANY	MANY



The three rare Pokémon always run away quickly, so it takes luck to catch them.

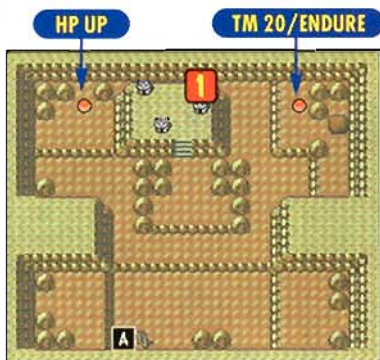

BASEMENT 1

Basement 1

	GOLD			SILVER		
	MORNING	DAY	NIGHT	MORNING	DAY	NIGHT
#19 RATTATA	MANY	MANY	MANY	MANY	MANY	MANY
#41 ZUBAT	FEW	FEW	FEW	FEW	FEW	FEW
#109 KOFFING	MANY	MANY	MANY	MANY	MANY	MANY
#126 MAGMAR	FEW	MANY	FEW	FEW	MANY	FEW

RIVAL! Battle 3



LEVEL 22	CROCONAW	WTR
LEVEL 22	BAYLEEF	GRS
LEVEL 22	QUILAVA AND	FRE
LEVEL 20	HAUNTER	GHO/PSN
LEVEL 18	MAGNEMITE	ELC/STL
LEVEL 20	ZUBAT	GHO/FLY

Your Rival has bulked up his Pokémon roster, and it's much tougher than before. He has a Magnemite that is a strong Electric-and-Steel-type. Use Ground- and Fire-types against the Rival's team—you should come out the winner. Use a type his starting Pokémon is weak against, too.

RECOMMENDED POKÉMON TYPES:
ELECTRIC, FIRE, GRASS, GROUND, WATER



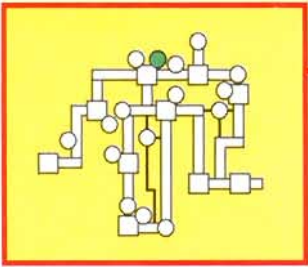

Tin Tower

The Legendary Bird, Ho-oh, lives on the roof of the Tin Tower. You can't go up the Tower without the Rainbow Wing, which you will get from the Radio Station Manager in Goldenrod City in Gold and from the old man in Pewter City in Silver.

First Floor

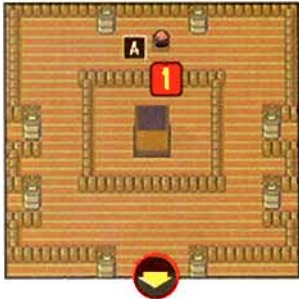

ECRUTEAK CITY
page 38

Second Floor

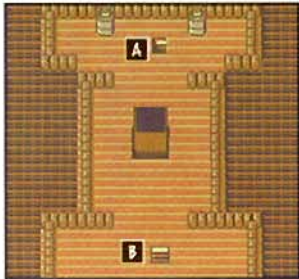

Third Floor

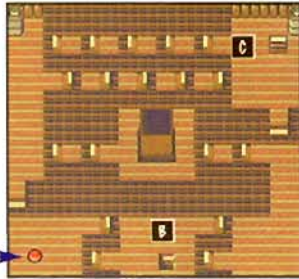

Fourth Floor

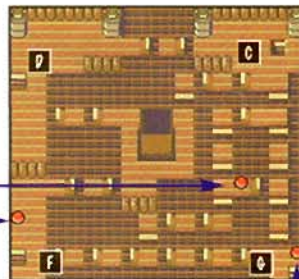

Fifth Floor

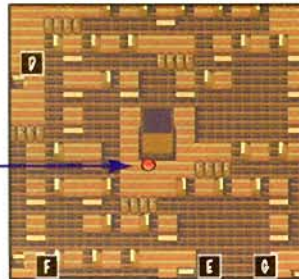

Sixth Floor

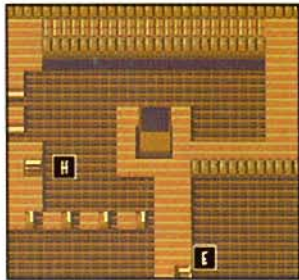

Seventh Floor

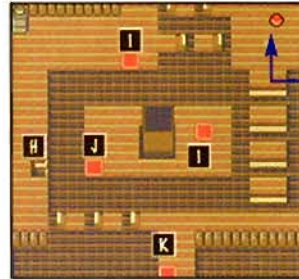

Eighth Floor

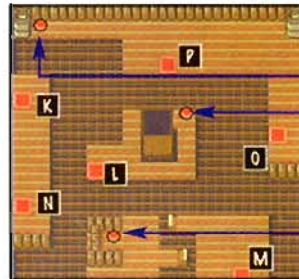

Ninth Floor

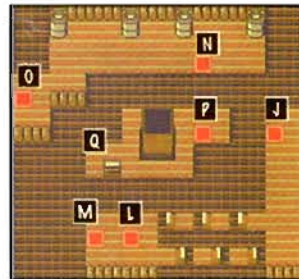

Rooftop



1 ASCEND THE TIN TOWER

If you're playing Gold, you will get the Rainbow Wing in Johto. If you're playing Silver, a monk will block the stairs on the first floor and you won't be able to continue up until you get the Rainbow Wing in Kanto. You'll have to wait to take the maze of floors to the top until well after you've beaten the Elite Four. Follow the letters on the maps to get to the top of the Tower.



2 HO-OH ON TOP

The Legendary Bird, Ho-oh, is on the Tower's roof. Ho-oh will be at Level 40 in Gold, and Level 70 in Silver. Save your game when you get to the rooftop, and be sure to have plenty of Ultra Balls on hand, and maybe a few Potions, Revives, and other helpful items. You can use the Escape Rope, Dig or Fly to leave the Tower quickly.



#250 HO-OH
TYPE: FIRE/FLYING

Route 38 & Route 39

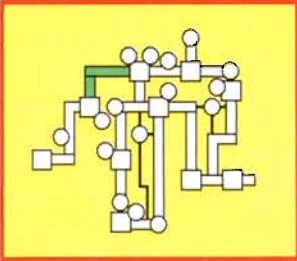

Routes 38 and 39 branch off in many places, and quite a few Trainers are hanging out on the two roads. They're using Flying-, Electric-, Grass- and Water-type Pokémon, among others. Moomoo Farm is along the way, and one of its Miltank is ill. You might want to help it out.



ECRUTEAK CITY page 38

OLIVINE CITY page 42



1 MILTANK MALADY

Moomoo Farm has a sick Miltank that won't give milk. Feed it many, many Berries to make it recover. After it recovers, you will get TM 13, Snore, as a thank-you present. Moomoo Milk will also be available for purchase after the Miltank is healed. It restores HP.

#128 TAUROS TYPE: NORMAL

Like many larger Pokémon, Tauros does very well with attacks that take advantage of its substantial heft and its relatively strong attack power. Tauros are always male—if you want another Tauros, you'll have to leave it at the Daycare with Ditto.

Attacks
HORN DRILL
BODY SLAM
HYPER BEAM
EARTHQUAKE

HMs
NONE



#241 MILTANK TYPE: NORMAL



#209 SNUBBULL TYPE: NORMAL



#81 MAGNEMITE TYPE: ELECTRIC/STEEL

Magnemite used to be classified as an Electric-type, but in Gold and Silver, it is considered to be an Electric-and-Steel-type. The Pokémon does very well with Electric-type moves, and you can teach it the HM Flash so it can light up dark caves for you.

Attacks
THUNDERSHOCK
THUNDER WAVE
LOCK-ON
ZAP CANNON

HMs
FLASH

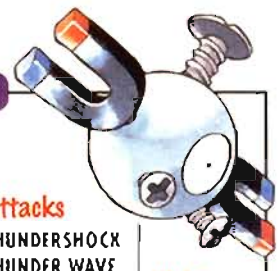

#83 FARFETCH'D TYPE: NORMAL/FLYING

Like many of its fine, feathered, flying-type friends, Farfetch'd has pretty low stats and HP. Flying-types can learn the essential Fly attack, which can help them avoid being hit and is very useful outside of battle.

Attacks
SAND-ATTACK
SWORDS DANCE
SLASH
FALSE SWIPE

HMs
FLY



LEVEL 30 #82 MAGNETON ELC/STL

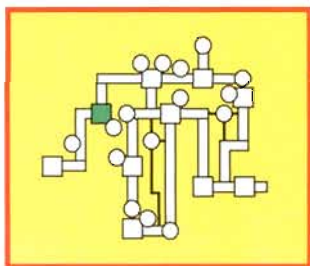

Olivine City

The port town of Olivine City has a couple of interesting attractions—the Lighthouse and the port for the high-speed watercraft, the S.S. Aqua. There's a problem at the Lighthouse that you need to attend to before you can even attempt to battle the city's Gym Leader.

#100 VOLTORB TYPE: ELECTRIC

Voltorb isn't much on looks, but it is one of the fastest Electric-type Pokémon that does extremely well with Electric-type attacks. You can always teach it Explosion to ensure that all of its battles go out with a bang.

LEVEL 30 #101 ELECTRODE ELC

Attacks
LIGHT SCREEN
SWIFT
EXPLOSION
MIRROR COAT

HMs
FLASH

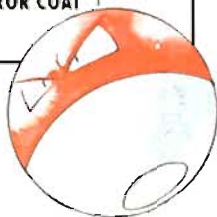

1 2 FISHING FOR ITEMS

GOOD ROD HM 04/STRENGTH

The man in the house (1) will give you the Good Rod, which will help you catch different and higher-Level Water-type Pokémon. The Sailor in the other house (2) gives you HM 04, Strength, which will help tremendously in the next city. Strength allows you to move the squarish rocks inside caves and runnels.

3 LIGHTHOUSE HELP

If you want to win Olivine City's Gym Badge, you'll have to head over to the Lighthouse where the Gym Leader is. The Lighthouse is full of Trainers trying to prove their worth, so be prepared for quite a few battles.



4 OLIVINE CITY GYM

You won't be able to battle in the actual Gym for a while. Visit the Lighthouse to find the Gym Leader, then work on her errand in the next city. When the Lighthouse's Pokémon is healed, the Gym Leader will head back to the Gym and you will be able to battle for the Badge.

Later: After you help the Gym Leader, Jasmine, heal the Pokémon in the Lighthouse, she will go back to the Gym and offer to battle you. She doesn't cut you any slack, even though you helped her with her problem.

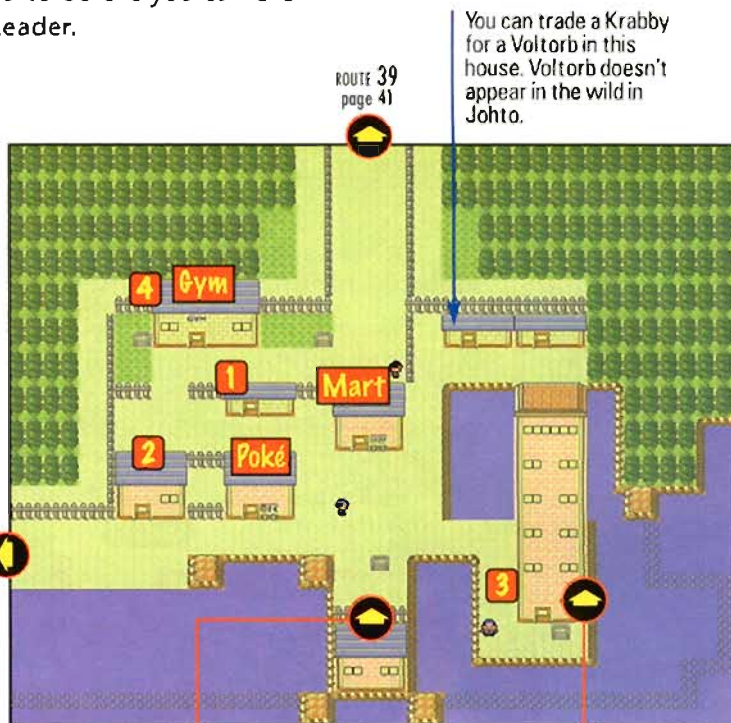

ROUTE 39
page 41

ROUTE 40
page 44

LIGHTHOUSE
page 43

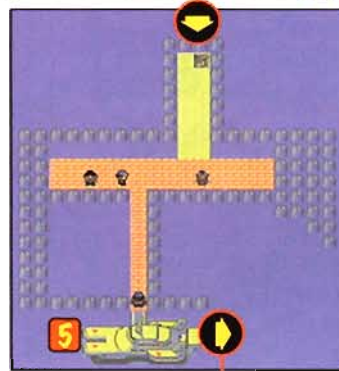

S.S. AQUA
page 62

POKÉMON MART

GREAT BALL	600
SUPER POTION	700
HYPER POTION	1,200
ANTIDOTE	100
PARALYZE HEAL	200
AWAKENING	250
ICE HEAL	250
SUPER REPEL	500
SURF MAIL	50

5 OLIVINE BAY

You can't really do anything at Olivine Bay until after you've defeated the Elite Four. It is where the S.S. Aqua docks, but you can't get on without a Ticker. Just ignore the area for now.

Later: After you beat the Elite Four and visit with Professor Elm, you will get the S.S. Ticket, which allows you to take the S.S. Aqua. The boat departs from Johto on Monday and Friday.



OLIVINE CITY GYM LEADER: JASMINE

LEVEL 30	MAGNEMITE	ELC/STL
LEVEL 35	STEELIX	STL/GRD
LEVEL 30	MAGNEMITE	ELC/STL

RECOMMENDED POKÉMON TYPES:
FIRE, GROUND, WATER

Jasmine prefers Steel-type Pokémon, which are powerful against Grass, Ice, Flying, Psychic, Bug, Rock, Ghost, Dragon, Dark and Steel Pokémon. If you take in Fire- and Ground-types, you should do pretty well. Steelix is vulnerable to Water-type attacks.

PRIZES: MINERAL BADGE/TM 23 (IRON TAIL)
Iron Tail decreases your opponent's defense by one level and is a powerful attack in its own right.

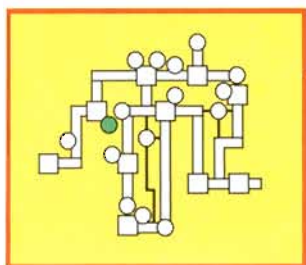
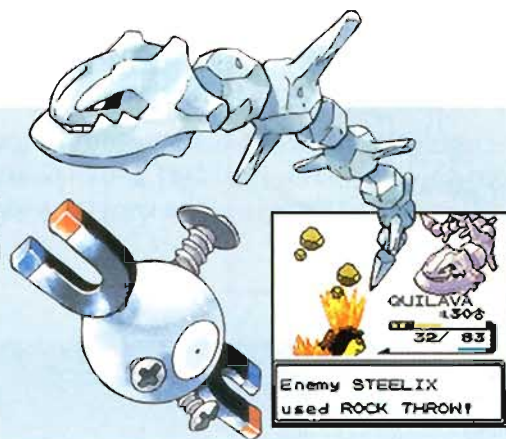

Lighthouse

The Lighthouse is used as a training area, and most of the Trainers inside use Water- or Flying-type Pokémon. An Electric-type will keep your opponents at bay.

First Floor



OLIVINE CITY
page 42

Second Floor

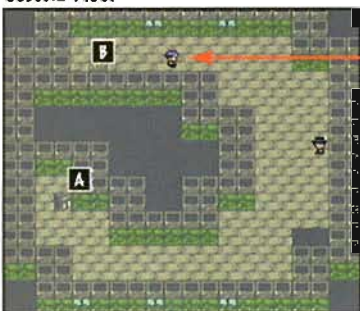

SAILOR: HUEY

TM 34/SWAGGER
GREAT BALL

Third Floor



ETHER

Fourth Floor

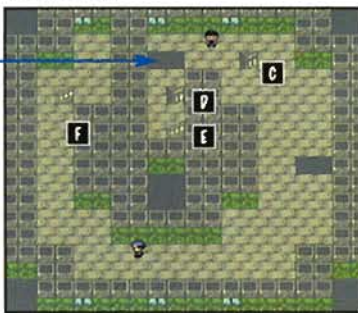

Drop down this hole, then go up the stairs, which are marked "D." Next, go up the "E" stairs to the fifth floor.

Fifth Floor



RARE CANDY

Sixth Floor



SUPER POTION

1 LIGHT'S OUT

Battle your way up the Lighthouse, following the path marked out on the maps. Make sure you've healed your Pokémon before you try to reach the top of the Lighthouse. When you get to the top of the Lighthouse you'll find Jasmine, who is nursing a sick Ampharos, Amphy, that usually powers the Lighthouse. Jasmine won't leave the sick animal to battle or get medicine, so it's up to you to head over the water to Cianwood City to get the medicine it needs at a drugstore. If



you don't pick up the medicine, you won't get to battle in the Gym.

Later: Get the medicine in Cianwood City (check page 46 for more information) and return to the Lighthouse. Give the medicine to Amphy to heal it—Jasmine



will finally agree to go to her Gym so you can battle.

Route 40 & Route 41

Some routes are actually waterways! You'll need a Pokémon in your party that can Surf, plus a Grass-type and an Electric-type to deal with the Trainers you'll meet along the way. It's a long surf to Cianwood City—make sure your Pokémon are fit to travel.

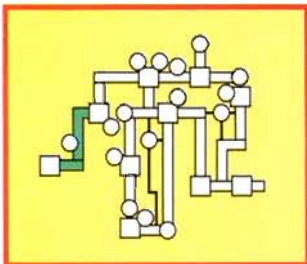

1 MONICA'S GIFT **SHARP BEAK**

On Monday, the oldest Day sibling, Monica, will be waiting to give you Sharp Beak, an item that powers up Flying-type attacks.

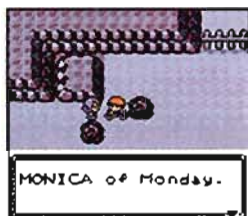

2 WHIRL ISLAND

You probably won't have HM 06 the first time you pass Whirl Island, and without it, you can't get very far there. Pass the whirlpools by your first time through. You'll be back soon to search for Lugia, the Legendary Bird.



#72 TENTACOOL TYPE: WATER/POISON

You will run into many Tentacool and Tentacruel on Routes 40 and 41. The scary-looking Water-and-Poison-types are well-suited to fighting Rock- and Fire-types. They can also learn the important watery HMs.

LEVEL 30 #73 TENTACRUEL WTR/PSN



Attacks	HMs
SUPERSONIC	CUT
ACID	SURF
BARRIER	WHIRLPOOL
HYDRO PUMP	

#98 KRABBY TYPE: WATER

It seems like almost every time you smash or move a rock, a Krabby runs out. Krabby and its evolution, Kingler, have an attack that seems custom-designed for them—Crab Hammer. In addition to the water-related HMs, Krabby can also learn Strength.

LEVEL 28 #99 KINGLER WTR

Attacks	HMs
STOMP	CUT
GUILLOTINE	SURF
PROTECT	STRENGTH
CRABHAMMER	WHIRLPOOL

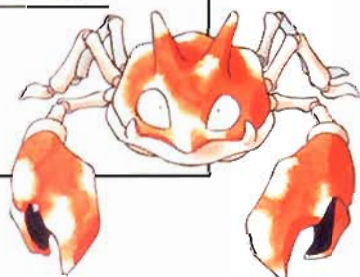

#129 MAGIKARP TYPE: WATER

Magikarp is a pretty useless Pokémon in battle. It can learn Splash, which does nothing, and Tackle, which doesn't do much when placed in Magikarp's flippers. Gyarados, Magikarp's evolution, is quite powerful, however.

LEVEL 20 #130 GYARADOS WTR/FLY

Only Gyarados can learn the listed abilities!



Attacks	HMs
BITE	SURF
DRAGON RAGE	STRENGTH
HYDRO PUMP	WHIRLPOOL
HYPER BEAM	WATERFALL

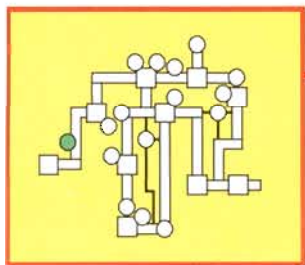

Whirl Island

The confusing maze of interconnected islets that make up Whirl Island can be frustrating, so study the maps below. You need to pick up Whirlpool from Team Rocket's Hideout to get near the Island and the Silver Wing from the man in Pewter City (Gold) or the Radio Station Manager in Goldenrod City (Silver) to find Lugia.

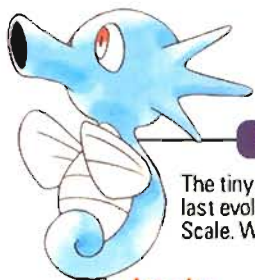
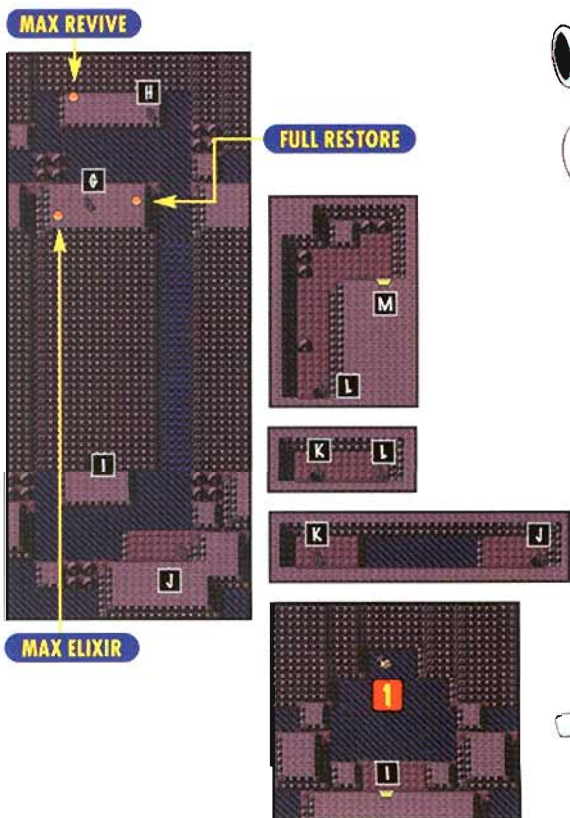
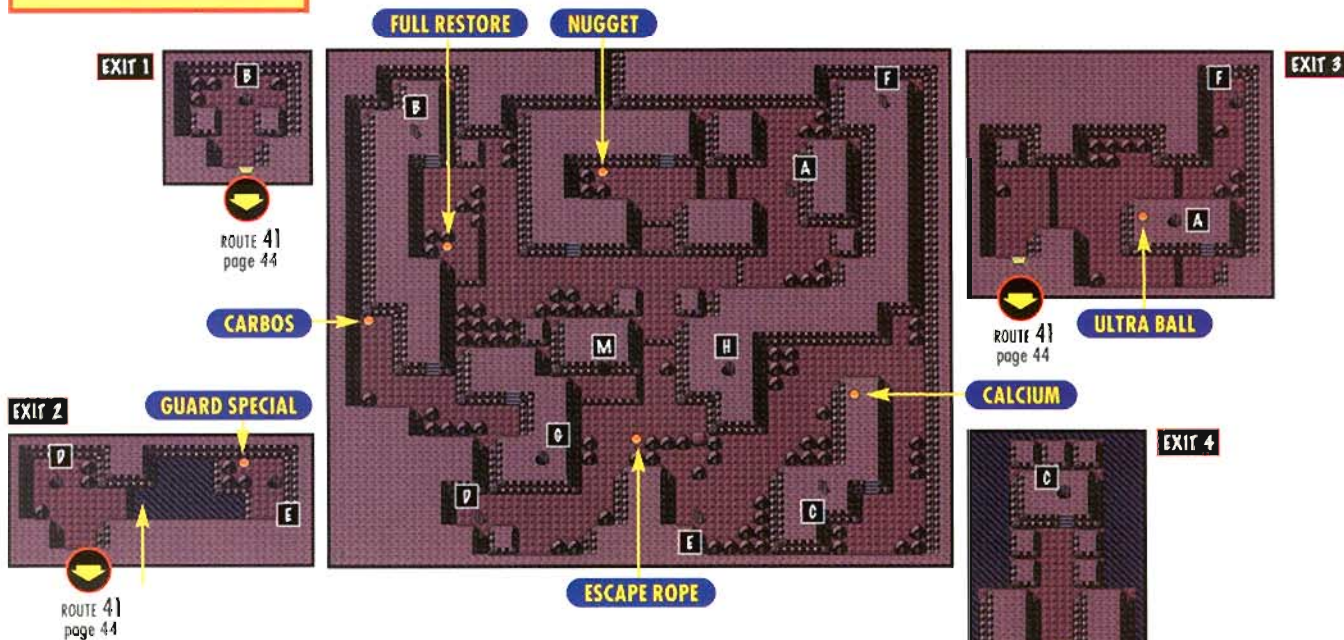

#116 HORSEA TYPE: WATER

The tiny sea creature's stats dramatically increase as it evolves. To land the last evolution, Kingdra, you'll need to evolve your Seadra with the Dragon Scale. Water- or Ice-type attacks work well with all three Pokémon.

Attacks
SMOKESCREEN
TWISTER
AGILITY
HYDRO PUMP

HMs
SURF

LEVEL 32	#117 SEADRA	WTR
SEE PG. 90	#230 KINGDRA	WTR/DRG



#249 LUGIA
TYPE: PSYCHIC/FLYING

1 LUGIA BELOW

There are many items scattered about the caves, but if all you're after is Lugia, enter the island on the top right and follow the letters on the map in this order: F, H, I.



You have only one chance to catch a Level-40 (Silver) or Level-70 (Gold) Lugia. Save the game before you try.

Cianwood City

You have to head to Cianwood City to get the medicine for the Ampharos in Olivine City, and while you're there, you should pick up the Gym Badge, too. You'll get something very cool if you win. Crush the boulders near the top of the city to find some interesting stuff.

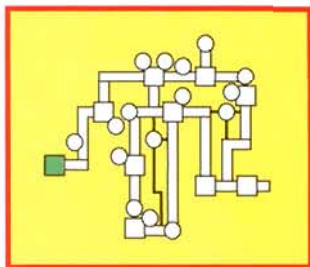

1 GET THE MEDS SECRET POTION

Cianwood's special drugstore-type Pokémon Mart has been around for over 500 years. If you talk to the woman to explain the Lighthouse dilemma, she will give you the Secret Porion. The next time you return, you will find regular Porions and similar Pokémon merchandise for sale. The building is not marked with a "Mart" sign.



2 CIANWOOD CITY GYM

You need to use Strength, which the sailor in Olivine City gave you, to make it to the Gym Leader battle in Cianwood City. If you push the boulders as shown, you're ready to battle.

If you hook up your Game Boy Printer before you talk to the man inside the house, he will take a picture of you and your Pokémon that you can print out.



After you beat the Gym Leader, his wife will present you with HM 02, Fly. You can travel to places you've already been very quickly with Fly.

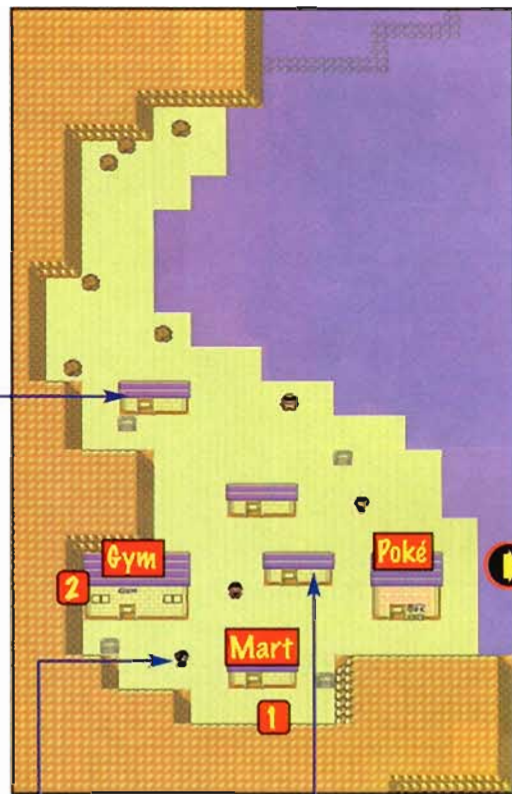

ROUTE 41
page 44

HM 02/FLY

BERRY JUICE



#213 SHUCKLE
TYPE: BUG/ROCK

Rumor has it that Shuckle can make juice from Berries. The Bug- and -Rock-type's other talents include the ability to learn Strength and Flash, both of which might come in handy.

Attacks	HMs
ENCORE	STRENGTH
SAFEGUARD	FLASH
BIDE	
REST	

POKÉMON MART

POTION	300
SUPER POTION	700
HYPER POTION	1,200
FULL HEAL	600
REVIVE	1,500

The Trainer in this house is afraid his Pokémon, Shuckie, a Shuckle, will be stolen, so he gives it to you for safe-keeping. If you return with it later and it is happy, the Trainer will give it to you as a present.



CIANWOOD CITY GYM LEADER: CHUCK

LEVEL 27 **PRIMEAPE** FTG
LEVEL 30 **POLIWRATH** WTR/FTG

Be sure to heal your Pokémon before entering the Gym—you'll have to battle two Trainers in a row. Move the boulders with Strength to reach Chuck. Try to knock Poliwrath out early, before it attacks with Dynamic Punch, which will almost certainly confuse your Pokémon.

PRIZES: STORM BADGE/TM 01 (DYNAMIC PUNCH)

The Storm Badge allows you to use Fly outside of battle, and Pokémon up to Level 70 will obey you.

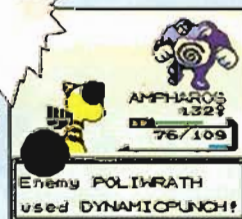
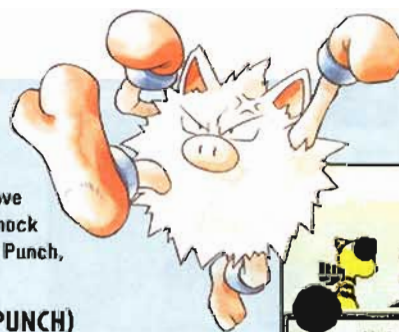

Route 42

Route 42 connects Ecruteak City to Mahogany Town, and it also provides several entrances to Mt. Mortar. Keep your eyes peeled for the second entrance to the mountain, found on the stretch of road that's surrounded by two ponds—it's easy to miss but very important!

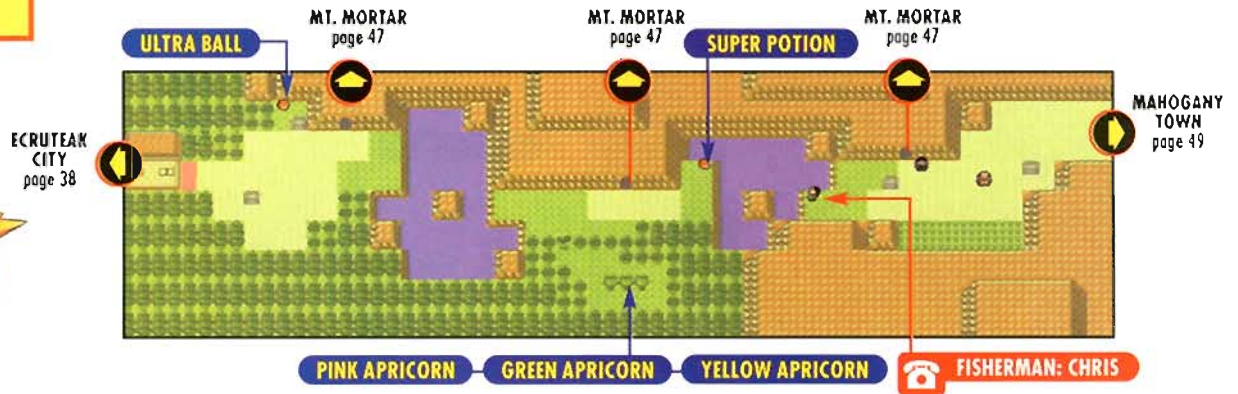
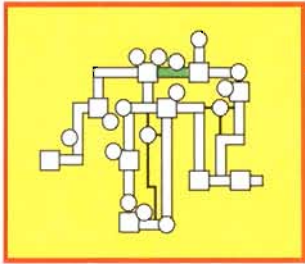

#21 SPEAROW TYPE: NORMAL/FLYING

Flying-types like Spearow always have to watch out for Electric-types and Ice-types, but they're very good against Bug-, Fighting or Grass-types. Spearow evolves into Fearow at Level 20

LEVEL 20 #22 FEAROW NRM/FLY

Attacks

FURY ATTACK
PURSUIT
DRILL PECK

HMs

FLY

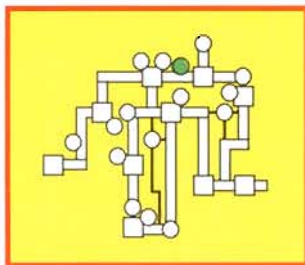

Mt. Mortar

To conquer the inside of the mountain properly, you'll need to bring along Pokémon that use Surf, Flash, Strength, and Waterfall. An Escape Rope or a Pokémon that knows Dig will help if you get lost. You won't have Waterfall the first time you visit, so you'll have to come back.

#201 MARILL
TYPE: WATER

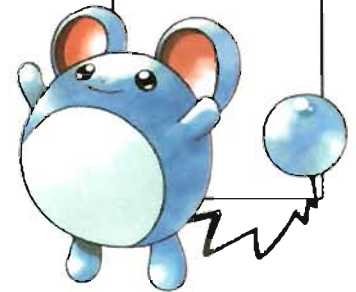

First & Second Floor

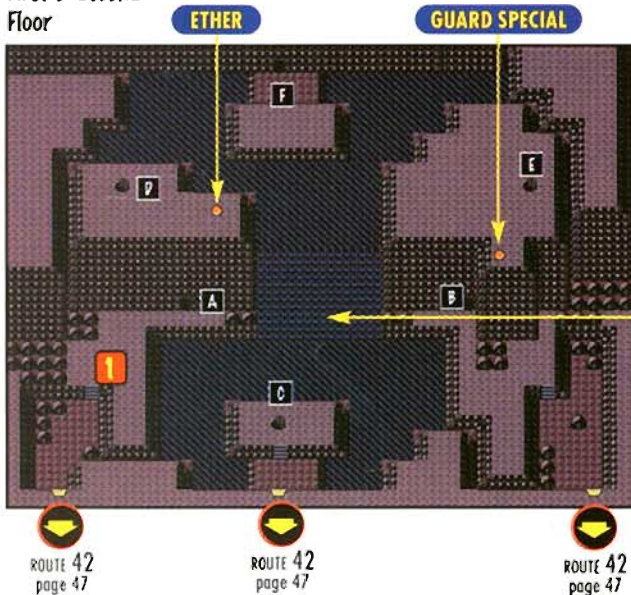

Later: You can't really explore the cave until you've got Waterfall and are able to use it outside of battle. You'll pick up Waterfall on the Ice Path, and you'll be able to use it outside of battle after you defeat Blackthorn City's Gym Leader. Don't forget to come back and have a look around!

1 IT'S MARILL!

Marill is pretty tough to catch—it doesn't appear very often, and when it does, it will be on the dirt parts of the map, even though it's a Water-type. Talk to Hiker Parry on Route 45 and register his phone number. He will eventually call you with information about Marill.



Second Floor

ELIXIR DRAGON SCALE ESCAPE ROPE

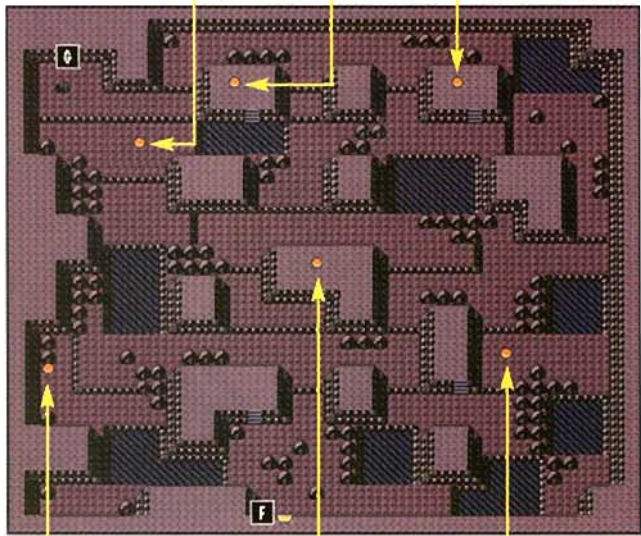

RARE CANDY TM 40/DEFENSE CURL MAX POTION

First Floor

MAX REVIVE ESCAPE ROPE

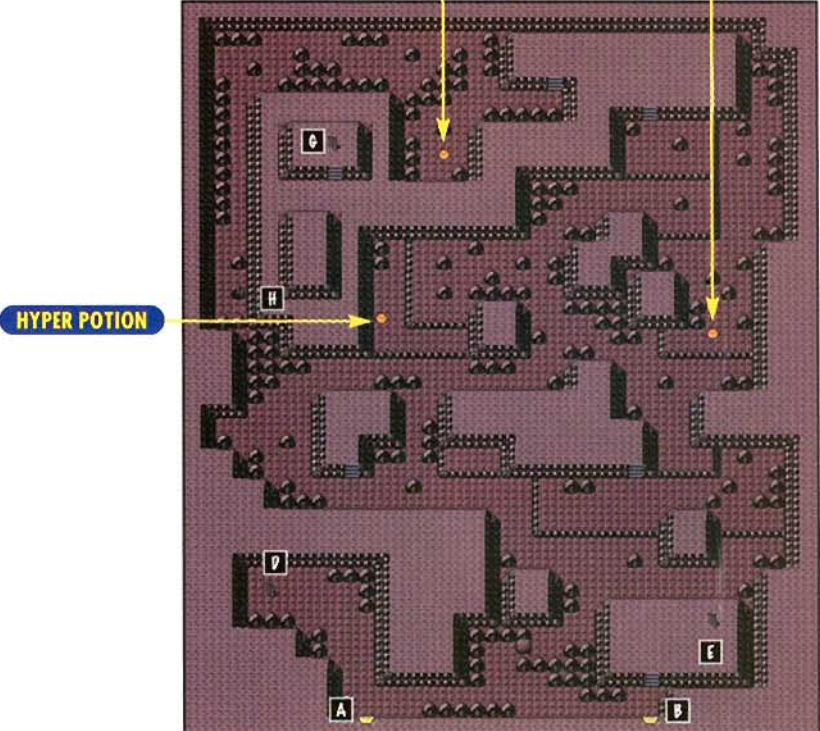

HYPER POTION

Basement 1

HYPER POTION

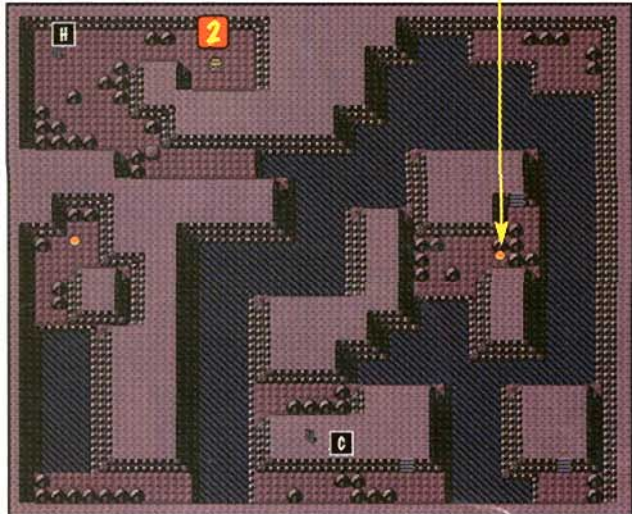

2 UP THE WATERFALL

Enter the middle entrance to Mt. Mortar, then Surf up to the Waterfall. Use Waterfall to move up the Waterfall and Surf up to the door marked "F." From there, Surf across the small pools of water to pick up the really good items that are lying around the mountain.



Later: From "F" on the second floor, work your way up and around to "G" to reach the first floor. Go up, then down to reach "H." Walk to the right to find the Karate King, Blackbelt Kyo. If you defeat him, he will give you a rare Fighting-type Pokémon, Tyrogue.

#74 GEODUDE TYPE: ROCK/GROUND

Trade your Graveler to someone you trust to evolve it into Golem. Geodude, Graveler and Golem are very weak against Water-types because of their dual Rock-and-Ground type.

LEVEL 25 #75 GRAVELER RCK/GRD
TRADE #76 GOLEM RCK/GRD

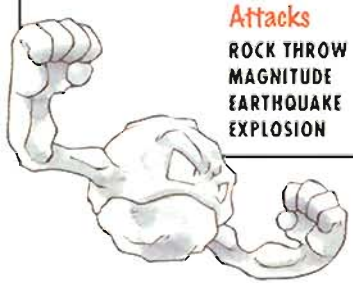

Attacks
ROCK THROW
MAGNITUDE
EARTHQUAKE
EXPLOSION

HMs
STRENGTH

#66 MACHOP TYPE: FIGHTING

Machop also reaches its final evolution through a trade. Trade your Machoke to someone you trust—it will grow into a Machamp. Then ask for it back very nicely.

LEVEL 28 #67 MACHOKE FTG
TRADE #68 MACHAMP FTG



Attacks
KARATE CHOP
SEISMIC TOSS
FORESIGHT
CROSS CHOP

HMs
STRENGTH

#118 GOLDEEN TYPE: WATER

Mt. Mortar is swimming with Goldeen. This Water-type has a sharp horn on its head, and two of its best attacks, Horn Attack and Horn Drill, take advantage of it. Goldeen evolves into Seaking at Level 33.

LEVEL 33 #119 SEAKING WTR

Attacks
SUPERSONIC
HORN ATTACK
HORN DRILL
AGILITY

HMs
SURF
WATERFALL

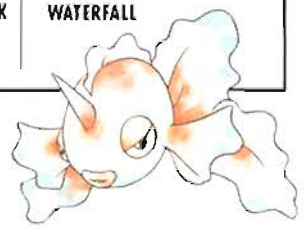

Mahogany Town

You will run into a number of oddities and road blocks when you first wander into Mahogany Town. You won't be able to enter the Gym or Route 44. The Pokémon Mart is selling really strange items, and there's a rumor that a red Gyarados has appeared at the Lake of Rage.

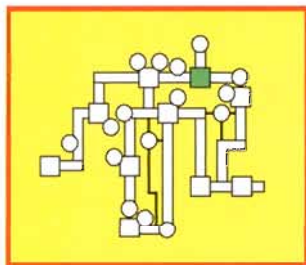

1 MESSED-UP MART

Something isn't quite right about the Pokémon Mart in Mahogany Town. They're selling bizarre items, including Slowpoke Tail...could this be related to what happened at Slowpoke Well?

Later: When you come back to the shop with Lance after you've visited the Lake of Rage, it's obvious that the shop is actually a cover for Team Rocket's hideout! When they're completely defeated, the store will become a normal Pokémon Mart.

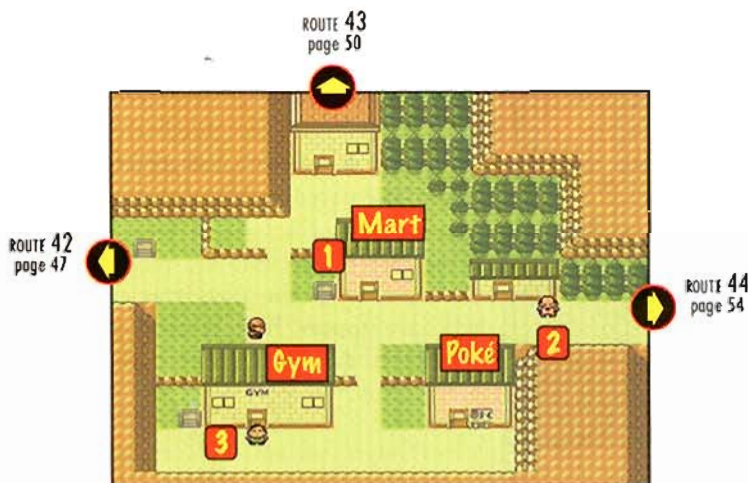

POKÉMON MART

ROCKETS	
TINY MUSHROOM	500
SLOWPOKE TAIL	9,800
POKÉ BALL	200
POTION	300
MAN	
RAGE CANDY BAR	300

POKÉMON MART

RAGE CANDY BAR	300
GREAT BALL	600
SUPER POTION	700
HYPER POTION	1,200
ANTIDOTE	100
PARALYZE HEAL	200
SUPER REPEL	500
REVIVE	1,500
FLOWER MAIL	50



2 ALL THE RAGE

The old man will block the road leading to Route 44. He will try to sell you Rage Candy Bars, which raise a Pokémon's HP by 20. No matter how many you buy, the guy won't let you pass. He won't leave until you defeat Mahogany Town's Gym Leader and solve the Goldenrod Radio Station dilemma.



3 MAHOGANY TOWN GYM

Do you know where you're going to? It's not the Gym, at least not at first. You have to walk up to the Lake of Rage before you can do anything else in the town.

Later: After you and Lance take Team Rocket down, the guy blocking the door will be gone and you'll be able to enter the Gym to battle. The inside of the Gym has an icy-slick floor, so be sure to follow the pattern shown at left to reach the Gym Leader.



MAHOGANY TOWN GYM LEADER: PRYCE

LEVEL 27	SEEL	WTR
LEVEL 29	DEWGONG	WTR/ICE
LEVEL 31	PILOSWINE	ICE/GRD

Pryce prefers Pokémon of the chilly variety, including Piloswine, an Ice-and-Ground-type. Ideally, you will deal with the Ice-type-attack-favoring Pokémon very differently. Use a tough Water-type on Piloswine. Pick a Fire-type for your battle with Dewgong and an Electric-type to duke it out with Seel.

PRIZES: GLACIER BADGE/TM 16 (ICY WIND)

The Glacier Badge grants you the power to use Waterfall outside of battle. You will pick up Waterfall in the next area.



RECOMMENDED POKÉMON TYPES:
ELECTRIC, FIRE, WATER

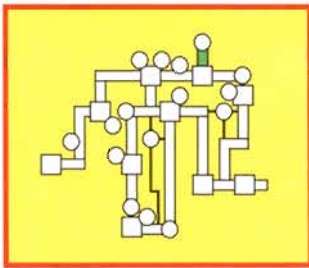

Route 43

Take Route 43 to reach the Lake of Rage. Team Rocket seems to be in charge there, which can't be a good thing.

1 TAKE THE TOLL?

If you have the extra money and you don't mind paying it to Team Rocket, you can walk up the paved path and through the gate to get to the Lake of Rage. If you don't want to part with the money, walk around through the grass instead. After you have stopped Team Rocket for good, the regular guard will return to the gate.

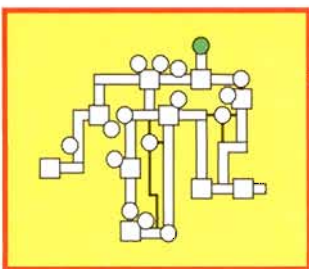

Lake of Rage

Strange things are happening at the Lake of Rage. Gyarados are taking over the waters, which were once packed with Magikarp. Team Rocket is at it again!

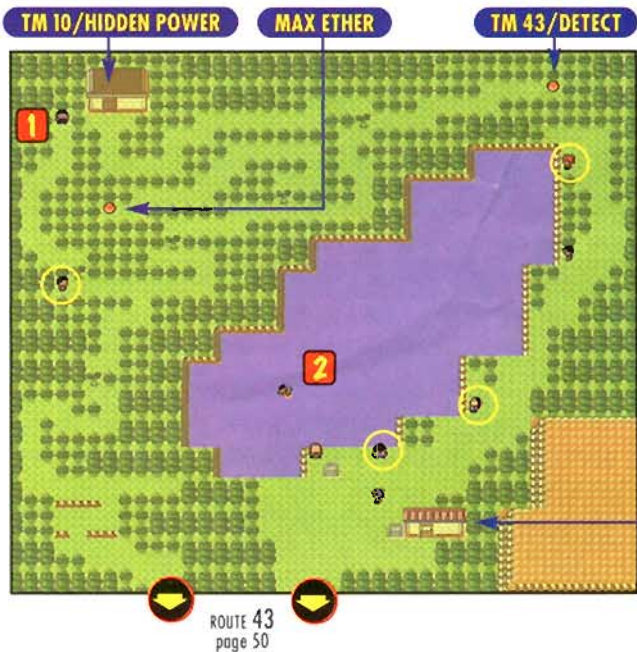

1 WESLEY OF WEDNESDAY BLACK BELT

Visit the Lake of Rage on a Wednesday to talk to Wesley. He will give you Black Belt, which increases the power of Fighting-type attacks. As with all the Day siblings, you will get the item only once.



ETHER
After Team Rocket is defeated, talk to the Master Fisherman in this cabin. He will measure any Magikarp you've caught. If your Magikarp is larger than the record posted on the sign in front of the house, you will receive Ether as a prize.

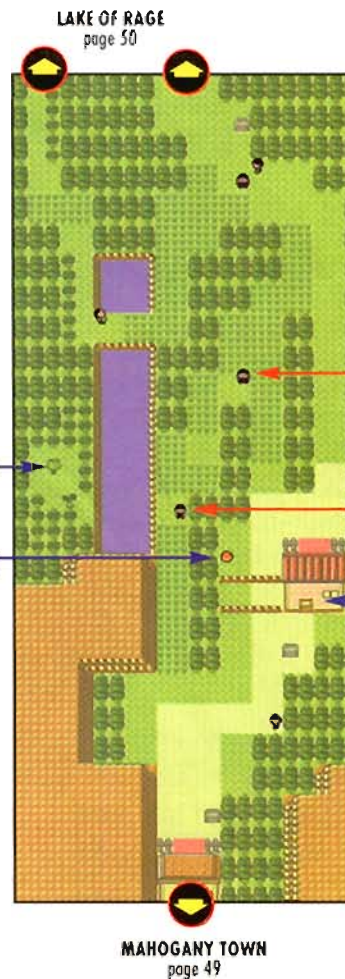

POKéMANIAC: BRENT

PICNICKER: TIFFANY

TM 36/SLUDGE BOMB

Later: After you've defeated Team Rocket, the real gatekeeper will come to stand guard in the gate. If you talk to him, he will give you TM 36, Sludge Bomb.

2 RED GYARADOS RED SCALE

Save your game, then surf up to the red Gyarados floating on the Lake of Rage, where a battle will begin. Try to catch the rare creature. Even if you don't catch it, you will pick up the Red Scale, which will interest Mr. Pokémon. After you defeat Team Rocket, return to the lake. New Trainers (circled in yellow) will appear for you to battle.



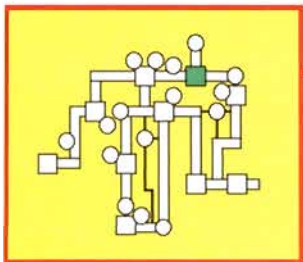

Rocket Hideout

Team Rocket supposedly disbanded three years ago, but it seems they're back! They're conducting a cruel experiment that is filling the Lake of Rage with Gyarados. After you capture or defeat the red Gyarados, a Trainer named Lance will ask for your help against Team Rocket.

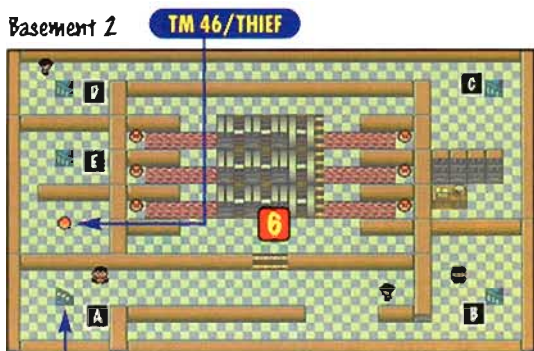
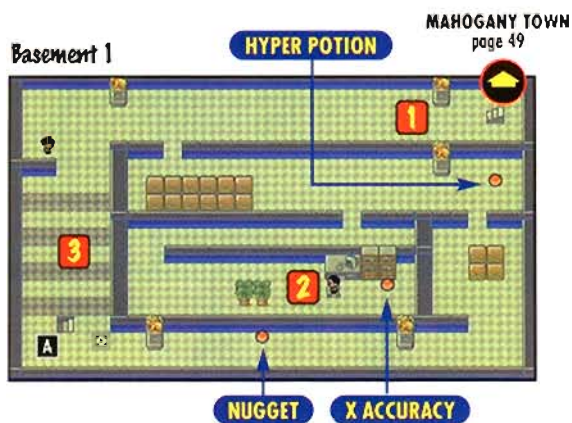

Lance will help you by healing your Pokémon here, but only once. Then you're on your own.



1 2 DOUBLE ROCKET

When you pass in front of the Persian statues, an alarm will bring two Team Rocket members running to battle you. Try to reach the PC in the center room to shut off the alarms.



3 TRIP THE TRAPS

Pokémon are hiding in the floor. The first time you step on one of the tiles marked on the diagram with a red dot, a Pokémon will attack. Afterward, that part of the floor will be safe to step on. Defeat a row, then use the diagram to the right to remember where you stepped to create a shortcut.

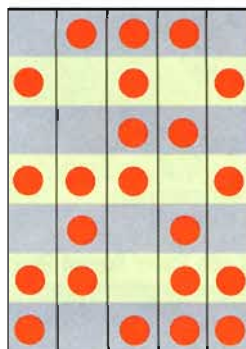

4 GET THE CODES **PASSWORD**

You'll need two passwords to get into the boss's room. Beat the two Rocket members at opposite ends of Basement 3 to get the passwords you need.

5 THE BIRD SINGS **PASSWORD**

After you enter the boss's office, talk to the Murkrow inside. It will give you the final password you need to stop the signal from transmitting.



6 SHUT OFF THE POWER

Defeat the last member of Team Rocket, then team up with Lance to fight the Electrode that are powering the transmitter that has turned all of those poor Magikarp into Gyarados. You'll receive HM 06, Whirlpool, when you've completed the task and Team Rocket is defeated.



#109 KOFFING TYPE: POISON

Team Rocket members often use Koffing or its evolution, Weezing. The Poison-types can learn toxic attacks that poison other Pokémon.

LEVEL 30 #110 WEEZING PSN

Attacks
SLUDGE
HAZE
EXPLOSION
DESTINY BOND

HMs
NONE



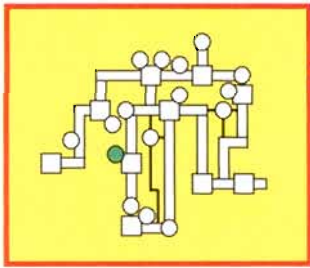

Radio Tower & Underground

After you've defeated seven Gym Leaders, Team Rocket will take over the Radio Tower in Goldenrod City. You'll have to go back to the Radio Tower and the Underground to finish off Team Rocket. There are lots of Team Rocket members in the Tower. Watch it!

1 LOCKED UP TM 11/SUNNY DAY

You need a key to open the shutters and use the stairs on the right. Until you get one, use the stairs in the middle of the building. After you defeat Team Rocket, the woman closest to the shutters will reward you with TM 11, Sunny Day.



Radio Tower First Floor



GOLDENROD CITY
page 32

Radio Tower Second Floor



Radio Tower Third Floor

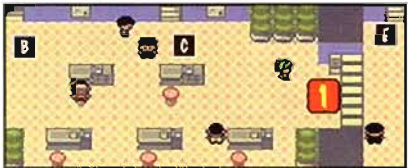

Radio Tower Fourth Floor



PINK BOW

After you take care of Team Rocket, DJ Mary will give you Pink Bow in appreciation

Radio Tower Fifth Floor



Underground Basement 1-1



GOLDENROD CITY
page 32

Underground Basement 1-2

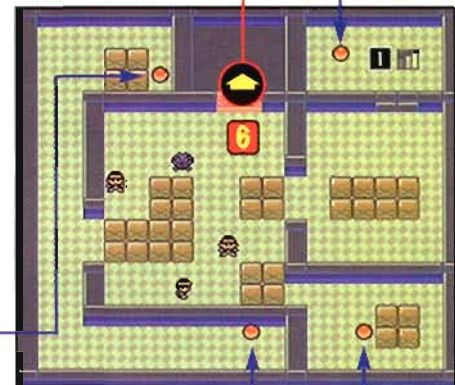

BURN HEAL

ETHER

ULTRA BALL

Underground Basement 2-2

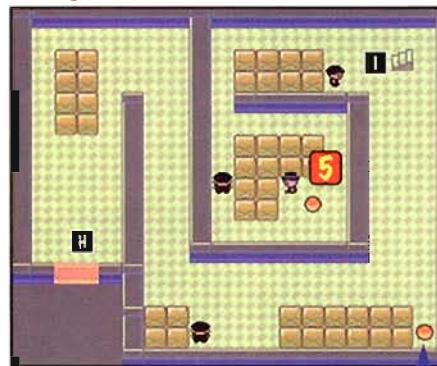

GOLDENROD CITY
page 32

MAX ETHER

Underground Basement 2-1

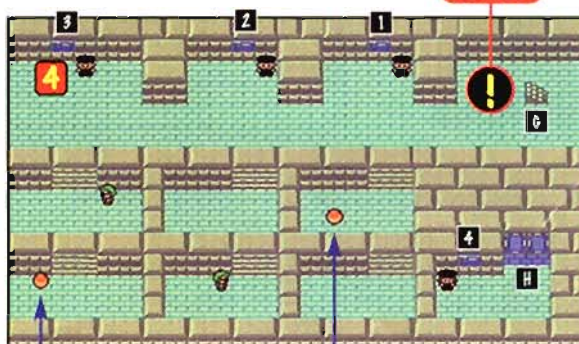

SMOKE BALL

FULL HEAL

2 MANAGER? BASEMENT KEY

After you defeat the fake Station Manager in a battle, he will tell you that the real Station Manager is being held in the locked-off area of the Underground. He will give you the Basement Key you need to open the locked area.



3 GO UNDERGROUND

Head back to the Underground area where you can get haircuts for your Pokémon and walk down to the locked door. Use the Basement Key to open the door then enter the Basement.



4 FLIP THE SWITCHES

It's a bit confusing, but if you flip the switches in Underground Basement 2-1 in reverse order (3, 2, 1) you will clear the way to the door at the bottom right and you will be able to continue on. If you get confused or mess up, return to B1—the



Your Rival has also come to defeat Team Rocket—not because he wants to help, but because he wants to prove his power. Send him packing.



switches will reset. After you talk to the Station Manager, flip switch 4 to get out.

5 GET THE KEY

TM 35/SLEEP TALK CARD KEY

Go through the doors and into the next room, where you'll find the real Station Manager. He will be very grateful to you and will gladly hand over his Card Key so that you can open the locked area of the Radio



Tower. Pick up TM 35, Sleep Talk, which is sitting very close to the Station Manager.

6 ATTENTION SHOPPERS!

If the area seems familiar, it's because it's the basement of the Goldenrod City Department Store. If you visit the Basement often, you should eventually be able to access every corner to pick up the items scattered about.

7 RETURN TO THE TOWER

RAINBOW WING (GOLD) SILVER WING (SILVER)

Use the Card Key to open the shutters that block the way to the stairs. Defeat Team Rocket's Leader and make Team Rocket call it quits. The Leader uses Dark- and Poison-type Pokémon, but he shouldn't give you much trouble. After Team Rocket is defeated, the real Station Manager will return, and he'll reward you with the Rainbow Wing in Gold and the Silver Wing in Silver. Use it to go back to find one of the Legendary Birds!



RIVAL! BATTLE 4



LEVEL 32	FERALIGATR	WTR
LEVEL 32	MEGANIUM	GRS
LEVEL 32	TYPHLOSION	FIR
	AND	
LEVEL 30	GOLBAT	PSN/FLY
LEVEL 28	MAGNEMITE	ELC/STL
LEVEL 30	HAUNTER	GHO/PSN
LEVEL 32	SNEASEL	DRK/ICE

Your Rival is still improving his team of Pokémon. This time, he's got five Pokémon, including the Dark- and Ice-type Sneasel. Fighting-types are best against Sneasel, but you will be fine if you use Rock- or Fire-types instead.



RECOMMENDED POKÉMON TYPES:

ELECTRIC, FIGHTING, FIRE, PSYCHIC, ROCK

#165 LEDYBA TYPE: BUG/FLYING

Like many Bug-types, Ledyba and its evolution, Ledian, are not very tough. Both creatures benefit greatly from moves that decrease the amount of damage they take from special or physical attacks.

LEVEL 18 #166 LEDIAN BUG/FLY

Attacks
LIGHT SCREEN
REFLECT
BATON PASS
DOUBLE-EDGE

HMs
FLASH

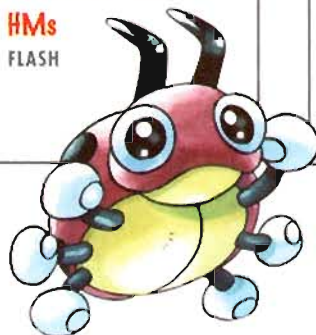

#167 SPINARAK TYPE: BUG/POISON

The Bug-and-Poison-type, Spinarak, is usually found at night. It works well with several different types of attacks, including the perfectly appropriate Spider Web and the always powerful Psychic.

LEVEL 22 #168 ARIADOS BUG/PSN

Attacks
NIGHT SHADE
LEECH LIFE
SPIDER WEB
PSYCHIC

HMs
FLASH



Route 44

There are quite a few Trainers on Route 44, and they're using a variety of Pokémon, including Water-, Flying-, Rock- and Fire-types. You should do very well against all comers if you bring along an Electric-type and a Water-type.

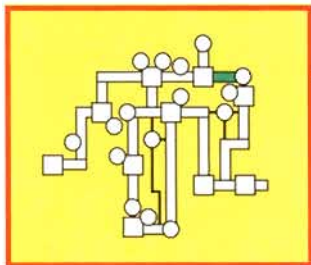

#114 TANGELA

TYPE: GRASS

Grass-type Tangela is best equipped with lots of matching Grass-type attacks. Beware of Fire-types—Tangela is flammable. Water-types and Ground-types should steer clear of Tangela.

Attacks	HMs
SLEEP POWDER	NONE
MEGA DRAIN	
STUN SPORE	
GROWTH	



MAHOGANY TOWN
page 49

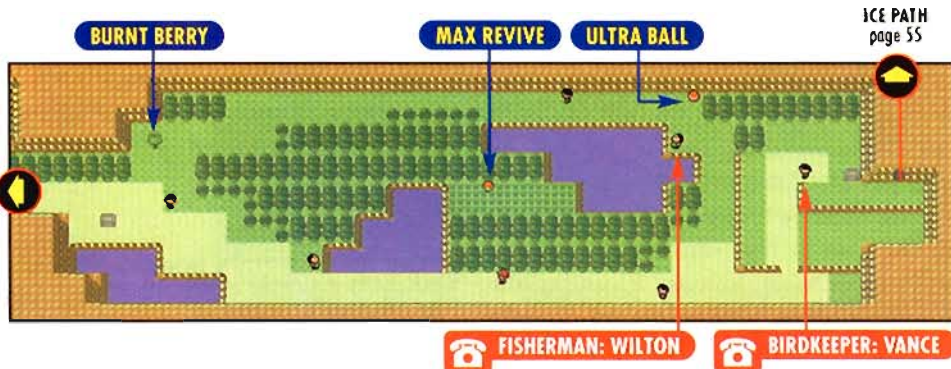

#175 TOGEPI

TYPE: NORMAL

You pick Togepi up rather early in the game, so you might want to teach it a couple of HMs. It doesn't take long for Togepi to evolve into Togetic if it likes you. If not, it may take quite a while for it to evolve.

SEE PG. 92 #176 TOGETIC NRM/FLY

Attacks	HMs
METRONOME	FLASH
ENCORE	FLY
SAFEGUARD	
DOUBLE-EDGE	

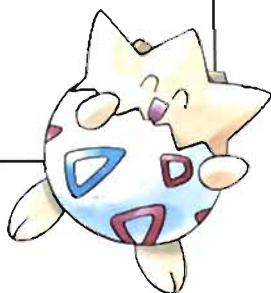

#124 JYNX

TYPE: ICE/PSYCHIC

The bizarre Ice-and-Psychic-type, Jynx, is common in the Ice Path. Jynx gives many Pokémon quite a chilly reception, but it would still be cool to take a female Jynx to the Pokémon Daycare with a male Pokémon or a Ditto to see what happens.

Attacks	HMs
LOVELY KISS	NONE
ICE PUNCH	
BODY SLAM	
BLIZZARD	



#108 LICKITUNG

TYPE: NORMAL

The large, pink creature with the enormous tongue is a Normal-type Pokémon with fantastic HP, especially compared to its other stats. Normal-types can learn many different sorts of moves, which makes them very versatile.

Attacks	HMs
LICK	SURF
SUPERSONIC	
DEFENSE CURL	
STOMP	



#204 PINECO

TYPE: BUG

Psychic-types are susceptible to Bug-type attacks, and Psychic-type attacks don't affect Steel-types very much, making Pineco and Forretress decent Pokémon to use in battle against Psychic Pokémon.

LEVEL 31 #205 FORRETRESS BUG/STL

Attacks	HMs
RAPID SPIN	STRENGTH
EXPLOSION	
SPIKES	
DOUBLE-EDGE	

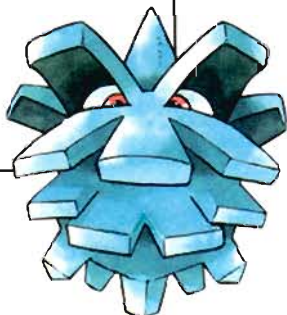

#69 BELLSPOURT

TYPE: GRASS/POISON

Bellsprout are extremely common Pokémon. You will run into them in many different grassy areas during the day and at night. Bellsprout evolves into Weepinbell at Level 21. You will need the Leaf Stone to get Victreebel.

LEVEL 21 #70 WEEPINBELL GRS/PSN
LEAF STONE #71 VICTREEBEL GRS/PSN

Attacks	HMs
GROWTH	CUT
SLEEP POWDER	FLASH
STUN SPORE	
RAZOR LEAF	

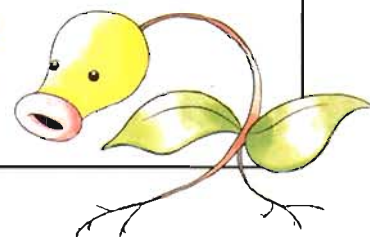

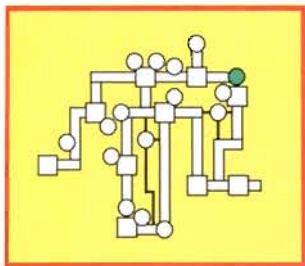

Ice Path

The Ice Path is very slippery in places, making your progress very difficult. Study the diagrams closely to make your way through the slick maze. You will also need a Pokémon with Strength to move boulders around so that you can continue on to Blackthorn City.

1 SLIPPING AND SLIDING

When you step on the ice floor of the path, you won't stop until you've hit a wall or a rock. It takes some planning and logic to get to where you want to go. You can use trial and error, or you can follow the paths shown below. No Pokémon will pop up on the slippery surface.

First Floor

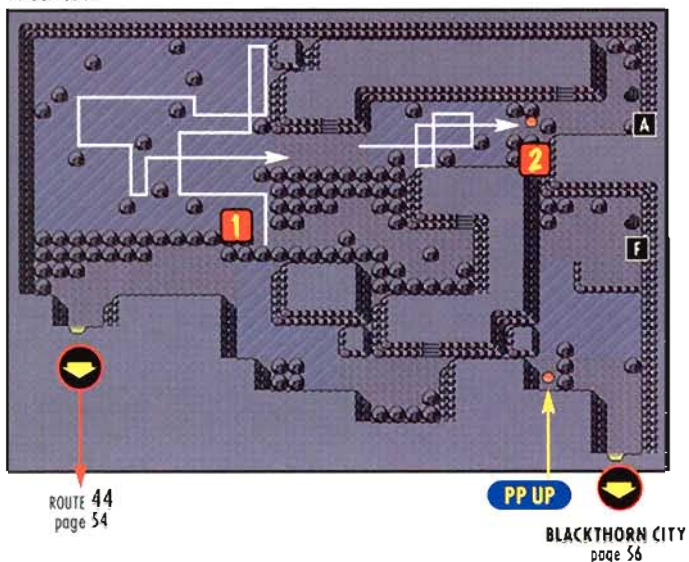

Basement 1-1

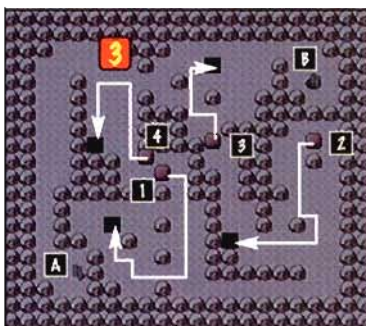

Basement 3



Basement 2-1

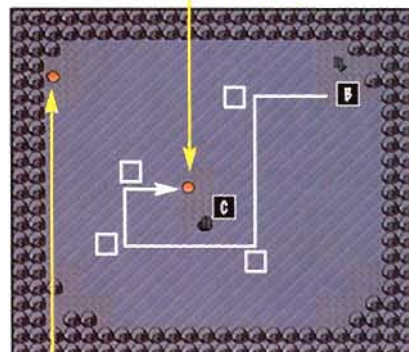

MAX POTION

Basement 2-2

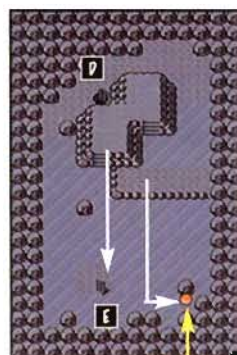

Jump down from the higher level, following the arrow on the right, to pick up TM 44, Rest

2 UP THE FALLS

HM 07/WATERFALL

After you pass the first slippery floor, you will see an item on the ground to the far right. It's HM 07, Waterfall, and it's essential in several areas, including Whirl Island, Mt. Mortar and many other places. Pick it up!



3 DOWN THE HOLE

You need to push the four movable boulders marked 1 through 4 down the holes as shown by the arrows to give yourself stopping places on the large, icy floor below. With the boulders in place, you can reach the ladder to B3. Move through the rest of the rooms as shown, stopping to pick up the very nice items on the floor—you will be in Blackthorn City in no time.

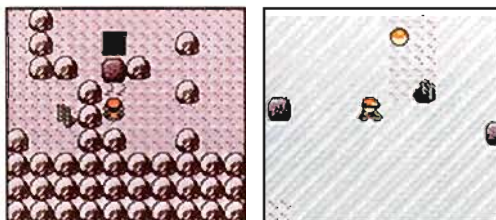

Basement 1-2

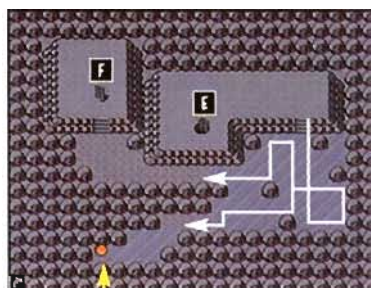

Iron is a very expensive item. If you'd like to pick up a free sample, follow the bottom white arrow down to the Iron. It's a quick trip

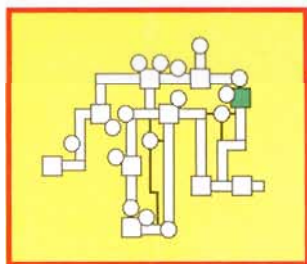

Blackthorn City

Blackthorn City is the home of Lance, the Elite Four alumnus you helped defeat Team Rocket. Clair, the current Blackthorn City Gym Leader, has vowed to be stronger than Lance, and the battle with her is your final Gym Leader battle in Johto. It won't be easy.

1 MOVES FORGOTTEN

The Move Deleter can make your Pokémon forget any move they've learned, including moves they learned from Hidden Machines (HMs), which were unforgettable in Red, Blue and Yellow. Assess your Pokémon, then use the service if you feel it's necessary.



2 SANTOS OF SATURDAY SPELL TAG

One of the Day siblings, Santos, shows up by the small hill below the Gym on Saturdays. He will give you Spell Tag, which increases the power of Ghost-type attacks.

3 THE DRAGON'S DEN

If you surf behind the Gym, you will come to the Dragon's Den. Only Dragon Handlers are allowed in, but after you beat Clair, she will give you permission to enter.



4 BLACKTHORN CITY GYM

The interior of the Blackthorn City Gym is a bit of a puzzle, so just follow the arrows to Clair. She's a proud person who claims to be the world's best Dragon Trainer. Even if you beat her, she won't give you the Gym Badge. She has another task for you to accomplish, first. That's rough!



BLACKTHORN CITY GYM LEADER: CLAIR

LEVEL 37	DRAGONAIR	DRG
LEVEL 37	DRAGONAIR	DRG
LEVEL 40	KINGDRA	WTR / DRG
LEVEL 37	DRAGONAIR	DRG

RECOMMENDED POKÉMON TYPES:
ELECTRIC, ICE

If you don't have a tough Ice-type, it might be best to raise one before you battle with Clair—unless your Pokémon are much higher than Level 40. You can use an Electric-type against Kingdra, but the Dragonair are best tackled with Ice-types.

PRIZES: RISING BADGE/TM 24 (DRAGONBREATH)

Pokémon of all levels will obey you, and you can use Waterfall outside of battle when you have the Rising Badge.

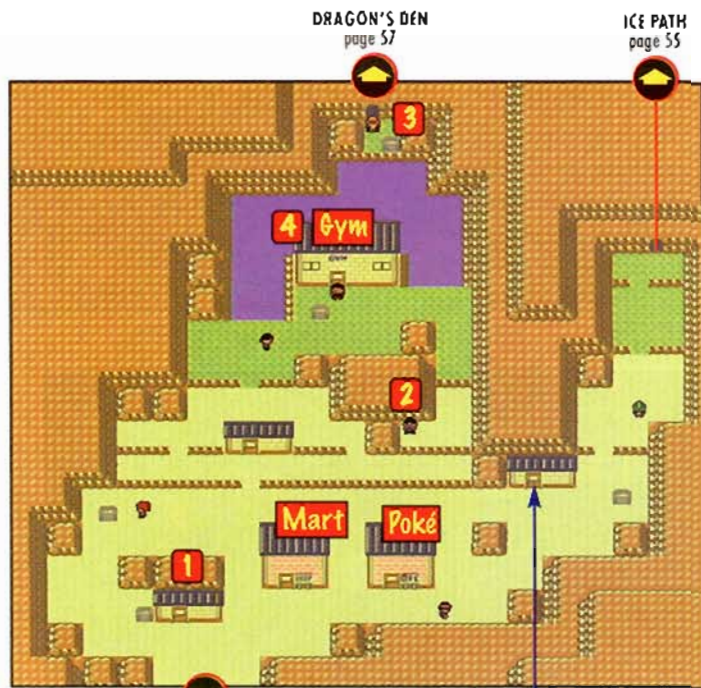

ROUTE 45
page 57

The person inside the house will ask you to trade a female Dragonair for a Rhydon. The Dragonair must be female, or the deal's off.



You'll need Strength to push the boulders on the second floor, which will cover the lava on the first floor and allow you to proceed to the battle with Clair.

POKÉMON MART

GREAT BALL	600
ULTRA BALL	1200
HYPER POTION	1,200
MAX POTION	2,500
FULL HEAL	600
REVIVE	1,500
MAX REPEL	700
X DEFEND	550
X ATTACK	500



Dragon's Den

Clair won't give you the Rising Badge until you've found the Dragon Fang inside the Dragon's Den. You need Pokémon that can use Surf and Whirlpool to get around the den.

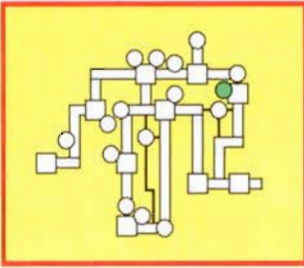

1 FANGTASTIC DRAGON FANG

Clair's request isn't very hard to fulfill. Enter the Dragon's Den, go through the ladders and surf to the Whirlpool. Use Whirlpool, then surf down and to the right, until you reach the outcropping of land. Pick up Dragon Fang to make Clair will appear. She will somewhat reluctantly hand over the Rising Badge and TM 24, Dragonbreath. Professor Elm will call you to come back to his lab and pick up an item from him once you've picked up the last Badge.

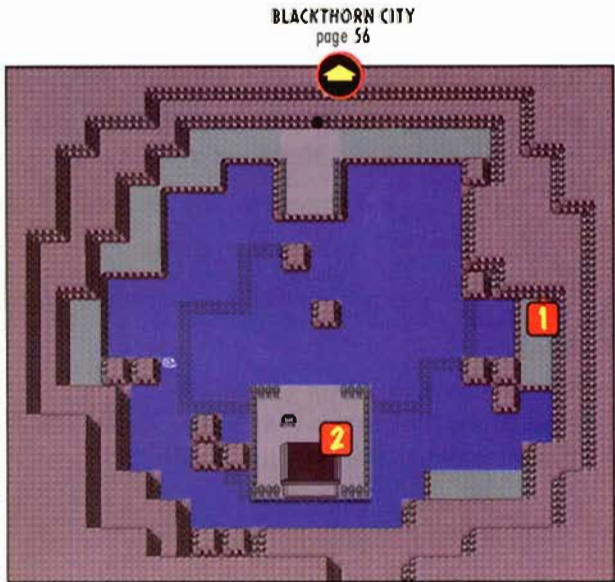

2 DRAGON SHRINE

The Dragon Shrine is dedicated to all the Dragon-type Pokémon said to live inside the cave. There won't be anything happening there at first.

Later: After the battle at Mt. Moon in Kanto, your Rival will become devoted to his training, and you can come back here to watch him train. He trains on Tuesdays and Thursdays.

Route 45 Route 46

Routes 45 and 46 are built into a mountain, so you will be traveling downhill. You can't walk back up, but you can fly. There are many good items scattered along the routes. Make a few trips to pick them up.

1 PARRY

Take the far-left path down Route 45 to talk to Parry. Register his phone number—eventually he will call with information about where to catch Marill. You can take the other paths to face the other Trainers and pick up items by flying back up to Blackthorn City then taking different paths back down.

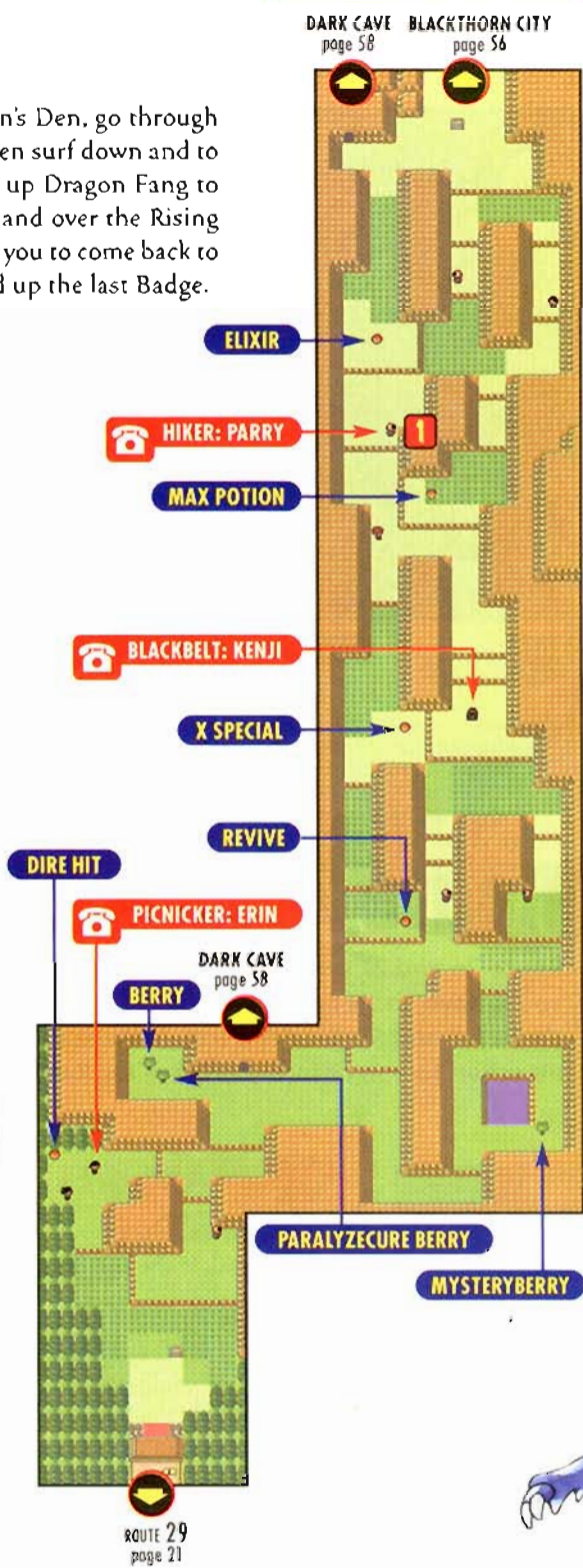

#214 HERACROSS TYPE: BUG/FIGHTING

Heracross is a Bug-and-Fighting-type, which is relatively unusual. Fighting-types are good to use against Normal-types. Beware Flying-types, which this Pokémon has a double weakness against.

- Attacks**
- HORN ATTACK
 - TAKE DOWN
 - REVERSAL
 - MEGAPHONE

- HMs**
- CUT
 - STRENGTH



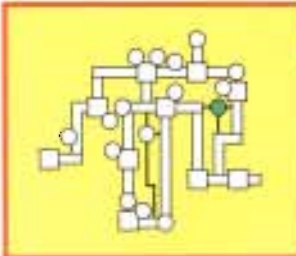

Dark Cave

You can enter the cave from Violet City, Blackthorn City, Route 31, Route 45 and Route 46. You'll need Flash to light your way through the cave and Rock Smash and Surf to find all the items inside. While there are a lot of fabulous items inside the cave, including TM 13, you don't have to enter it.

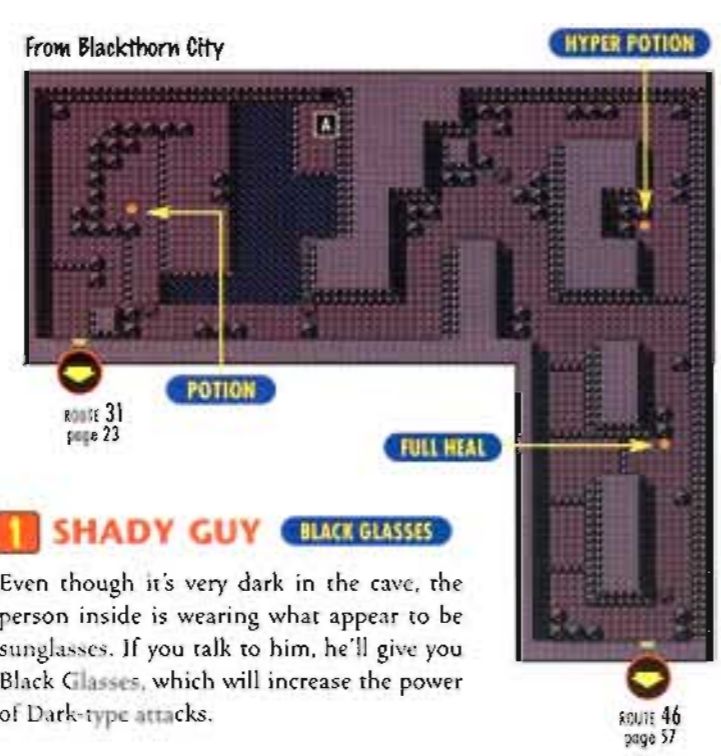
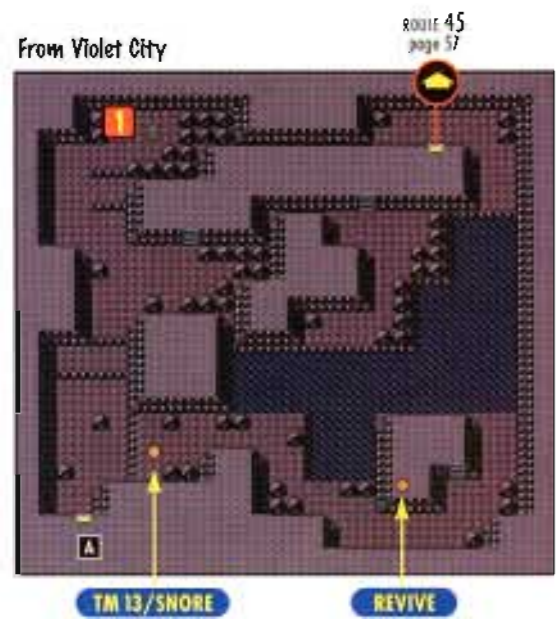

1 SHADY GUY BLACK GLASSES

Even though it's very dark in the cave, the person inside is wearing what appear to be sunglasses. If you talk to him, he'll give you Black Glasses, which will increase the power of Dark-type attacks.



Route 26 & Route 27

Route 26 and 27 are a little confusing, but they lead the way to Victory Road, so you'll have to get through them. You should bring along Pokémon that know Waterfall and Surf for the trip. Make sure your Pokémon are strong, healthy and attached to you before you leave for Kanto.



Clair from Blackthorn City will explain where you should go. Start in New Bark Town and surf over the water to the right of your house. You're on the way to Kanto and the Elite Four!

1 TRAIN WELL TM 37/SAND STORM

The woman in the house will check to see how devoted your Pokémon are to you. If she sees that the first Pokémon in your party is attached to you, she will give you TM 37, Sand Storm. Pokémon become attached to Trainers when they are healthy, used often, kept in the party and rarely made to faint. You can give your Pokémon items and haircuts to make them happy, too. If you treat your Pokémon well, they will treat you well, too.



2 DAY SIBLINGS' HOUSE

Enter the house if you want to see the Day Siblings' oath, which includes information about where and when each sibling appears in Johto. Of course, you already have the information, but it's a good place to check if you've missed a few of the siblings the first time around.



3 VICTORY ROAD

After a very long journey that includes surfing, battling and much item collecting, you will finally be on your way to Victory Road. You won't be able to pass until you have all eight Badges from Johto. Two men are blocking the paths that branch out to the left and the right. They won't be gone for a while. Just press ahead and worry about the two blocked paths later. You need more experience before you will be able to tackle the road to the left, anyway.



#77 PONYTA TYPE: FIRE

The galloping Fire-types, Ponyta and Rapidash, are extremely fast and have relatively high attack power. All Fire-types do very well against Grass-, Ice- and Bug-types, but they should watch out for Rock-, Ground- and Water-types.

LEVEL 40 #78 RAPIDASH

Attacks
STOMP
FIRE SPIN
TAKE DOWN
FIRE BLAST

HMs
NONE

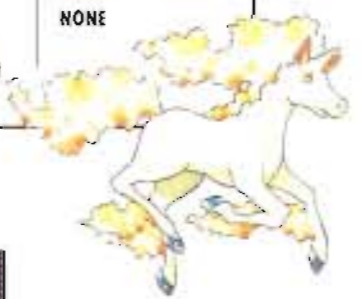

MOON STONE

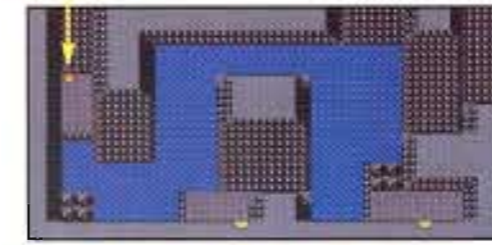

NEW BARK TOWN page 20

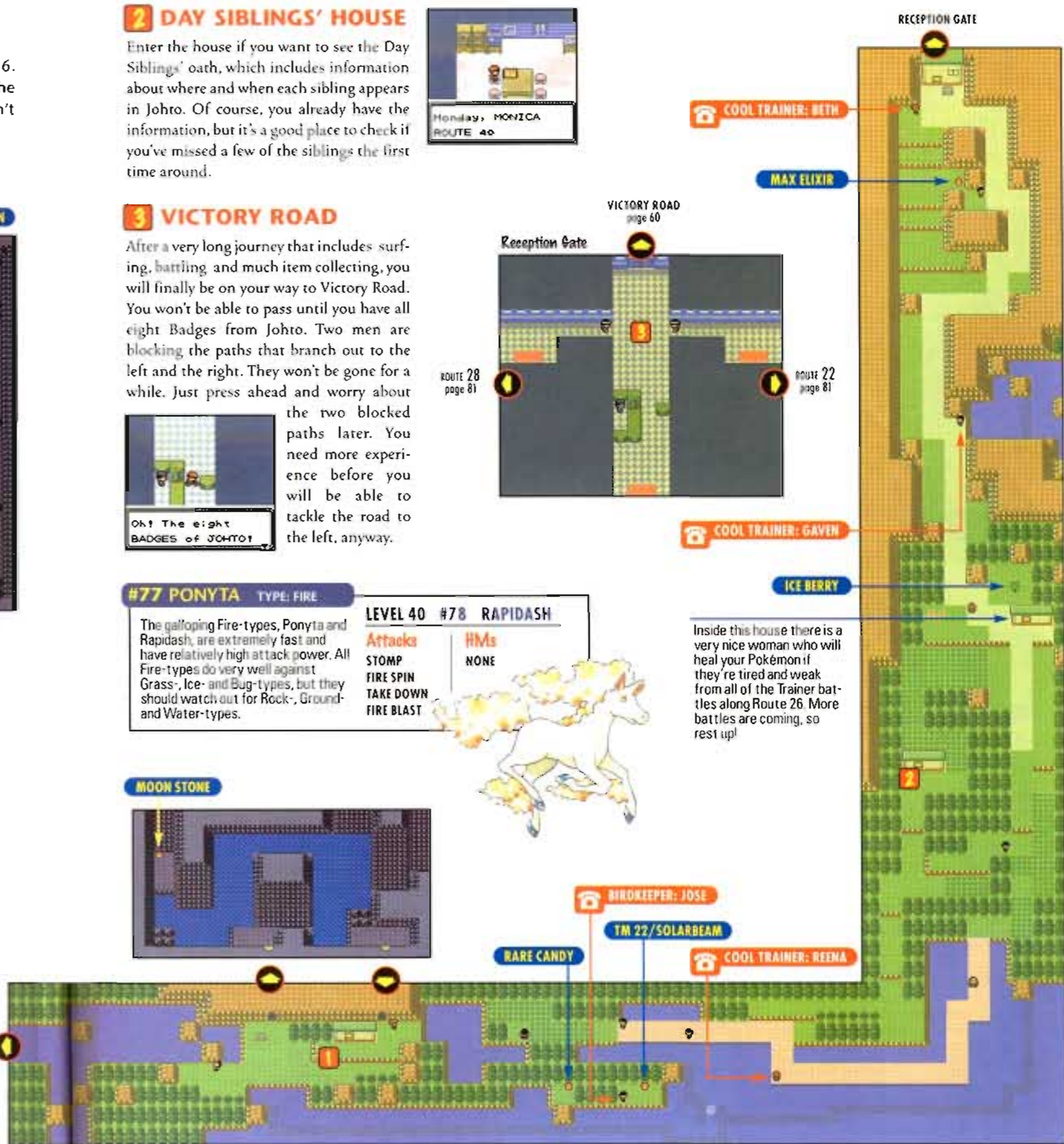

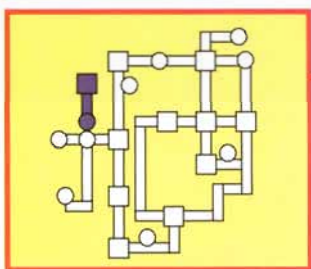

Victory Road, Indigo Plateau

You have one more obstacle before you make it to the Indigo Plateau and the Elite Four. The cave is really no big deal to get through, but the items inside the cave are a big deal! Pick up as many as you can, then head out to the Indigo Plateau.

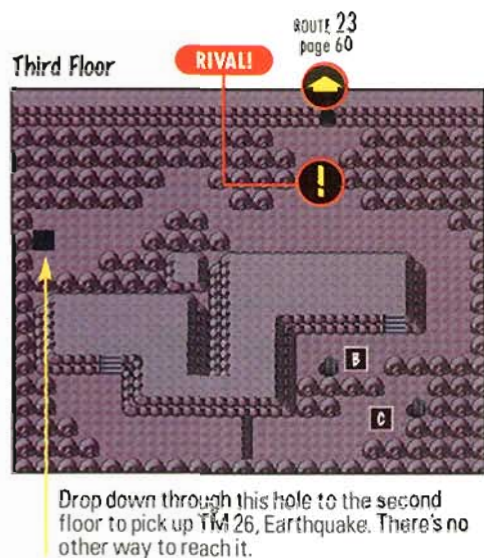
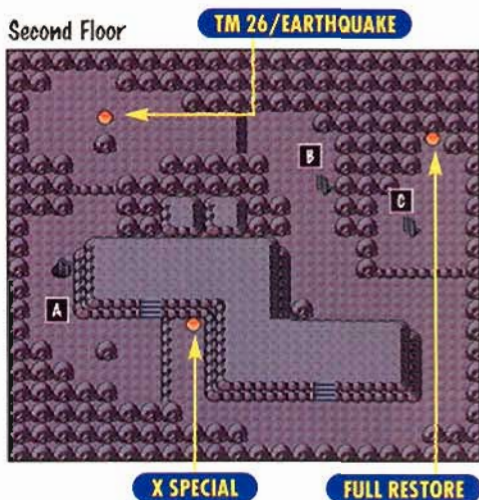
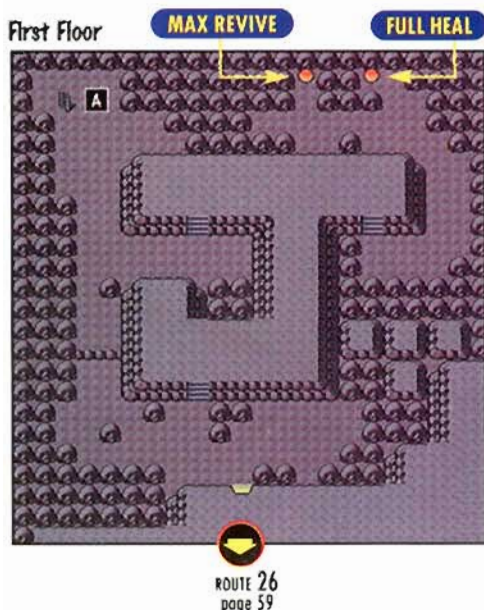

INDIGO PLATEAU
page 60

RIVAL! BATTLE 5



LEVEL 38	FERALIGATR	WTR
LEVEL 38	MEGANIUM	GRS
LEVEL 38	TYPHLOSION	FIR
	AND	
LEVEL 34	SNEASEL	DRK/ICE
LEVEL 34	MAGNETON	ELC/STL
LEVEL 35	HAUNTER	GHO/PSN
LEVEL 36	GOLBAT	PSN/FLY
LEVEL 35	KADABRA	PSY

When you try to leave the third floor of the cave, your Rival will challenge you to a battle, and he's added a sixth Pokémon to his team—Kadabra. Ideally, you'll have a Dark-type Pokémon such as Umbreon to battle Kadabra. If you don't have one, a strong Psychic-type or even an Electric-type is fine.

RECOMMENDED POKÉMON TYPES:
DARK, ELECTRIC, FIGHTING, FIRE, PSYCHIC



Route 23

Route 23 is just the tiny stretch of road between the cavellike road known as Victory Road and the Indigo Plateau. Not much will happen there.

1 SUPPLIES

Make sure you heal your Pokémon and pick up any items you might need before you take on the Elite Four. You can use the combined Pokémon Center and Mart every time you battle there.

Later: After you battle your Rival at Mt. Moon, he will appear at the Pokémon Mart/Pokémon Center every Monday and Wednesday, ready and willing to take you on again.

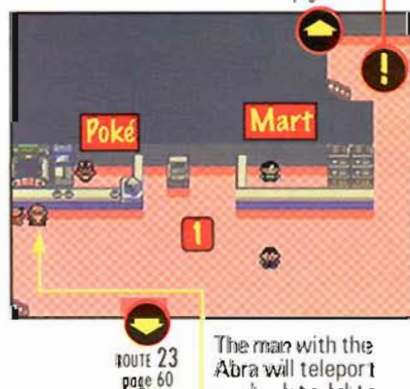

POKÉMON MART

ULTRA BALL	1,200
MAX REPEL	700
HYPER POTION	1,200
MAX POTION	2,500
FULL RESTORE	3,000
REVIVE	1,500
FULL HEAL	600

Vs. Elite Four

The Elite Four battle is misleading—you actually have to battle five excellent Trainers with very strong Pokémon. You can't stop at a Pokémon Center between battles, so you'd better bring some HP-restoring products, some Revives and other important items with you.

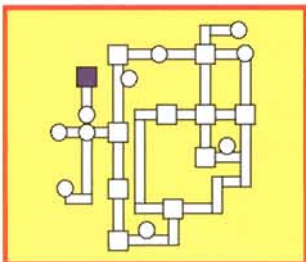

1 WILL

LEVEL 40	XATU	PSY/FLY
LEVEL 41	EXEGGUTOR	GRS/PSY
LEVEL 41	SLOWBRO	WTR/PSY
LEVEL 41	JYNX	ICE/PSY
LEVEL 42	XATU	PSY/FLY

RECOMMENDED POKÉMON TYPES:

DARK, ELECTRIC, FIRE, ICE, PSYCHIC

This Trainer's team are all dual types that include the Psychic-type. If you attack each Pokémon's other type's weakness, you should have no problems. For example, attack Xatu with an Electric-type, because Flying-types are weak against them. A very powerful Psychic- or Dark-type Pokémon, Level 55 or higher, could be used to combat the entire team on its Psychic-type.



2 KOGA

LEVEL 40	ARIADOS	BUG/PSN
LEVEL 43	FORRETRESS	BUG/STL
LEVEL 42	MUK	PSN
LEVEL 41	VENOMOTH	BUG/PSN
LEVEL 44	CROBAT	PSN/FLY

RECOMMENDED POKÉMON TYPES:

FIRE, PSYCHIC

Koga uses Bug-types and Poison-types, and with his first moves he'll try to poison your Pokémon. He'll also try to confuse your Pokémon, leaving them somewhat helpless. Take him out as quickly as you can with your Psychic-types and your Fire-types. The longer the battle goes on, the less likely it is that you'll emerge victorious.

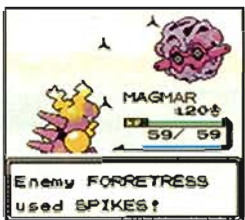

3 BRUNO

LEVEL 42	HITMONTOP	FTG
LEVEL 42	HITMONLEE	FTG
LEVEL 42	HITMONCHAN	FTG
LEVEL 43	ONIX	RCK/GRD
LEVEL 46	MACHAMP	FTG

RECOMMENDED POKÉMON TYPES:

FLYING, PSYCHIC, WATER

Unlike Koga, Bruno won't try to mess with your Pokémon's status. Instead, he will use Pokémon that strike hard and fast, hoping to knock your team out quickly and painfully. If you have a fast Psychic-type, use it to put the hurt on most of Bruno's team. Use a Water-type on Onix, the only non-Fighting-type in Bruno's team.

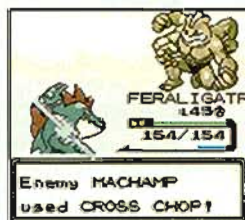

Prepare for Battle!

Every one of the Trainers is using Level-40 to Level-50 Pokémon, and they aren't exactly pushovers. Your Pokémon should be in that same ballpark, or higher, or you'll really be in for a thrashing. A good team will have six different types of Pokémon and would do well if it included a powerful Electric-type, a strong Ice-type and a seasoned Fire-type. Pick your team carefully, studying the recommendations for each member of the Elite Four. Use Pokémon that you're comfortable with, and be sure to heal them with items between matches. The battles are not easy, and if you lose to one Trainer, you'll have to start all over again!

4 KAREN

LEVEL 42	UMBREON	DRK
LEVEL 42	VILEPLUME	GRS/PSN
LEVEL 45	GENGAR	GHO/PSN
LEVEL 44	MURKROW	DRK/FLY
LEVEL 47	HOUNDOOM	DRK/FIR

RECOMMENDED POKÉMON TYPES:

FIGHTING, GROUND, PSYCHIC

Karen, the last of the Elite Four, uses Dark-type Pokémon in battle. Her Pokémon are particularly weak against Fighting-types, but Water-types and Electric-types will also work against her dual-type Dark Pokémon. Karen's other Pokémon share the Poison-type and will be easily dispatched with a Psychic- or Ground-type.



CHAMPION LANCE

LEVEL 44	GYARADOS	WTR/FLY
LEVEL 47	DRAGONITE	DRG/FLY
LEVEL 46	CHARIZARD	FIR/FLY
LEVEL 47	DRAGONITE	DRG/FLY
LEVEL 46	AERODACTYL	RCK/FLY
LEVEL 50	DRAGONITE	DRG/FLY

RECOMMENDED POKÉMON TYPES:

ELECTRIC, ICE

Yes, it's the same Lance from the Lake of Rage. He's grateful for your help, but he's also the Champion, so you have to beat his team of mostly Dragon-types. His team is united in its Flying-type, so an Electric-type will deal damage to every member of the team. Dragon-types are weak against Ice-types, so a powerful Ice-type Pokémon should also be in your party.



S.S. Aqua

The S.S. Aqua takes Pokémon Trainers from Olivine City in Johto to Vermilion City in Kanto. The boat ride is relatively short, but you'll still have time for a little adventure at sea. Pop into all the rooms—you can gain experience with Pokémon battles, and you'll find some good items, too.

1 AQUA, MAN

Professor Elm presents you with an S.S. Ticket after you've beaten the Elite Four. Go to Olivine City's dock and talk to the people there. The last person will ask to see your ticket and show you to the boat. After your first boat trip, the boat will operate only on certain days.

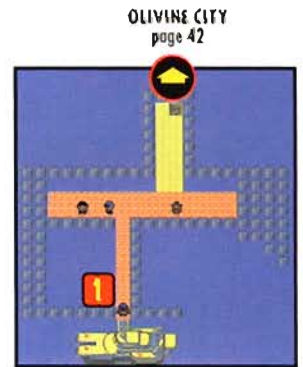

2 GRANDBABY

The old man in room H needs your help. His granddaughter wandered off, and he'd like you to find her for him. He will give you the Metal Coat, an item that your Onix might take a liking to, if you can find her.

Captain's Quarters First Floor

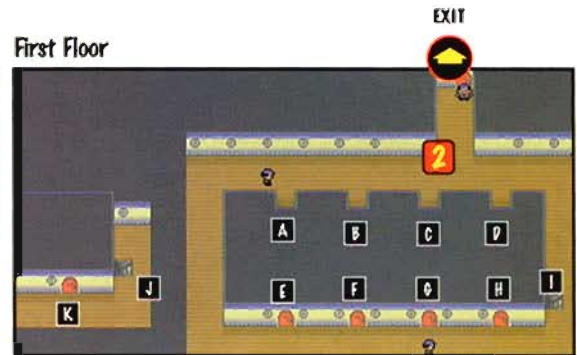

3 GET BACK TO WORK!

The sailor blocks your way to the rooms in the basement. He won't let you wander around belowdecks until you've rounded up his buddy. Search for the lazy sailor in room B, which is right next to your cabin.



After the lazy sailor mutters an excuse for sleeping on the job, he'll get back to work, and his less lazy buddy will let you pass.

3 A CAPTAIN AUDIENCE

Make your way to room K, the Captain's Quarters. The old man's granddaughter is in the room harassing the Captain. If you get the little scamp back to the old man's room, he will give you Metal Coat. After you've completed the search for the girl, you'll see an announcement that the boat has arrived at Vermilion City.



Take a nap on the bed to revive weary Pokémon. On your second boat ride and every trip after, you can make the boat arrive instantly at your destination by resting on the bed.

First Floor Rooms



METAL COAT

Basement-1

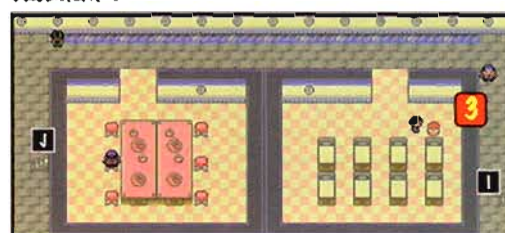

Vermilion City

Your first ride on the S. S. Aqua takes you to Vermilion City. If you've visited Kanto before in Red, Blue or Yellow, you are still in for some surprises—many things around Kanto have changed. If this is your first visit, you have a lot of exploring to do!

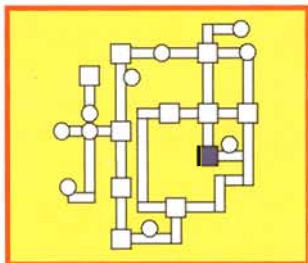

1 CRUISIN'

After the first trip to Kanto, the boat will follow a regular schedule. It departs from Vermilion City on Wednesdays and Sundays, and it departs from Olivine City on Mondays and Fridays. You can return to Johto by walking if you can't wait for the boat to leave.

2 LEADER OF THE PACK

RARE CANDY **POKÉ DOLL**

If you talk to the President of the Pokémon Fan Club, he will start telling you a very long story. If you listen to his entire story, he'll give you Rare Candy for your polite attention.



Later: After you've spoken to Copycat in Goldenrod City, return to the Pokémon Fan Club and talk to the guy at the table. He will listen to your story about Copycat's missing Poké Doll and ask you to return it to her.

3 SNOOZIN'

Snorlax is blocking the way to Route 11 and Diglett's Cave. You'll need to get a few things done before you'll be able to get Snorlax out of your way for good.



Later: After you help out at the Power Plant and pick up the expansion card for your Pokégear in Lavender Town, you will be able to move Snorlax. Set your Pokégear's radio to "Pokémon Flute" to wake Snorlax and get it out of your way. It's the only chance you have to catch Snorlax.

POKÉMON MART

ULTRA BALL	1,200
SUPER POTION	700
HYPER POTION	1,200
REVIVE	1,500
PARALYZE HEAL	200
AWAKENING	250
BURN HEAL	250
LITBLUE MAIL	50

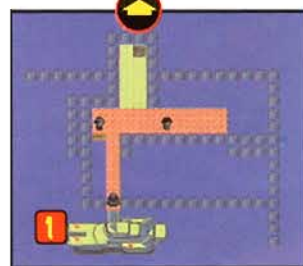
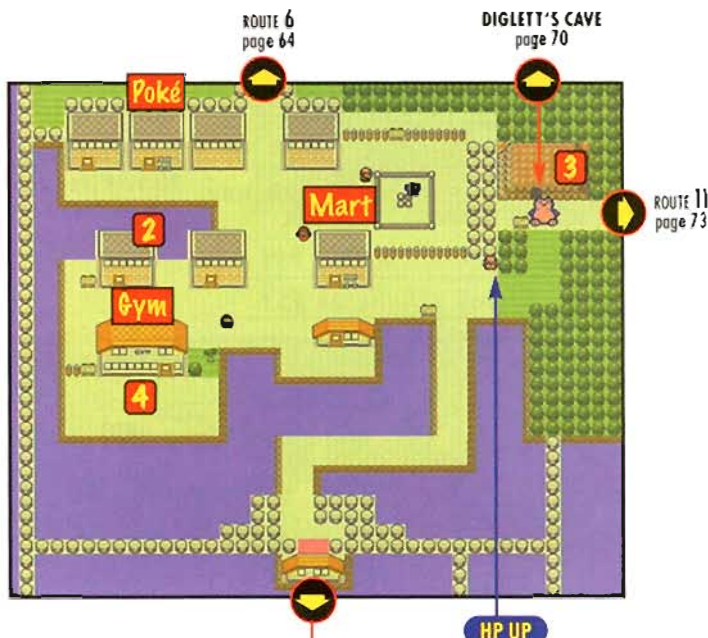

Later: Talk to the old man after you've collected all of the badges in Kanto. He will give you HP Up to congratulate you for your fine effort.

4 VERMILION CITY GYM

Cut the tree blocking the way to reach Vermilion City Gym. Lt. Surge, the Gym Leader, is very fond of Electric-type Pokémon—try not to be shocked.



VERMILION CITY GYM LEADER: LT. SURGE

The traps that once guarded Vermilion City Gym are gone, but Lt. Surge is still in residence. If you take a good Ground-type into battle, you won't be touched by the electrical onslaught of Surge's Electric- or Steel-type Pokémon.

RECOMMENDED POKÉMON TYPE:

GROUND

PRIZE: THUNDER BADGE



Route 6

Route 6 is a tiny little road that connects Vermilion City with Saffron City. The building in the upper right is the entrance to the Underground Path that also connects the two cities. The Underground Path will be closed until the Power Plant fiasco is fixed.

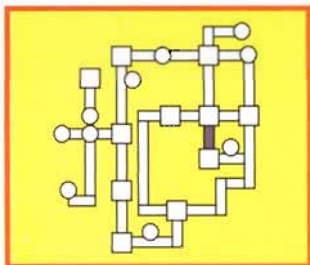

#63 ABRA TYPE: PSYCHIC

Abra are relatively common in Gold and Silver. Catch a wild Abra and raise it to an Alakazam for a dependable, Psychic-type addition to your party. Most of the powerful attacks are available only to Kadabra or Alakazam.

LEVEL 16 #64 KADABRA PSY
TRADE #65 ALAKAZAM PSY

Attacks

KINESIS (#64, #65)
RECOVER (#64, #65)
PSYCHIC (#64, #65)
REFLECT (#64, #65)

HMs

FLASH

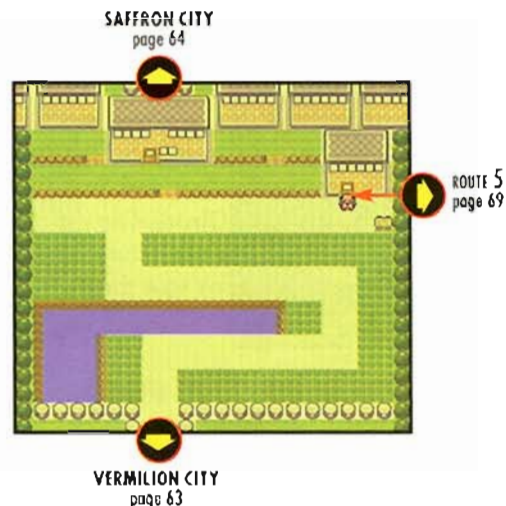
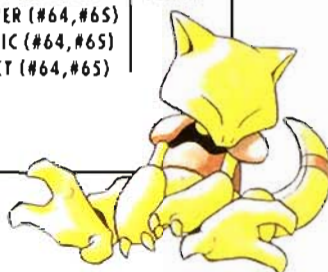

Saffron City

Saffron City is home to many interesting places including Silph Co. and the Train Station. The problem at the Power Plant has stopped the train from running...maybe it's a good idea to find the Power Plant and get things straightened out!

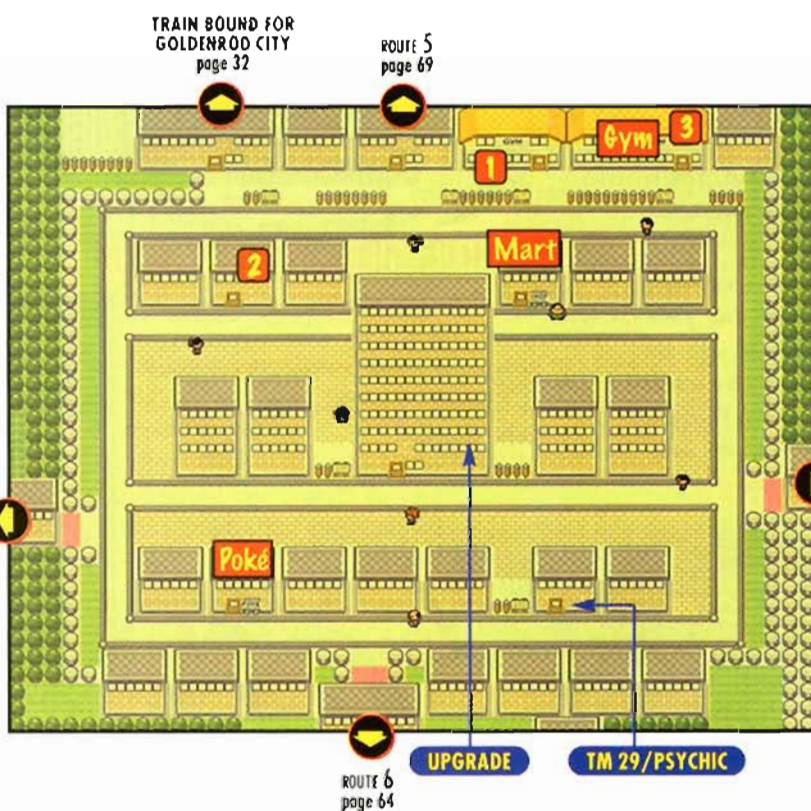
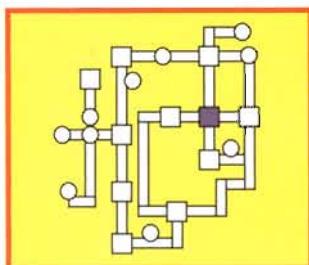

1 DOJO MOJO FOCUS BAND

The Fighting Dojo's master, Blackbelt Kyo, has gone to Johto to train. His acolyte will give you Focus Band, an item that allows a Pokémon to survive any attack without fainting by leaving it with 1 HP.



POKÉMON MART

GREAT BALL	600
HYPER BALL	1,200
HYPER POTION	1,200
MAX POTION	2,500
FULL HEAL	600
X ATTACK	500
X DEFEND	550
FLOWER MAIL	50



See page 48 for information about Blackbelt Kyo in Johto.

2 BE A DOLL PASS

After the Power Plant incident has been resolved, head upstairs in Copycat's house, where she will tell you about her missing Clefairy Doll. Head back to the Pokémon Fan Club in Vermilion City to get the Poké Doll for her.



Later: After you return the Poké Doll to Copycat, she will give you the Pass, which allows you to travel by train between Saffron City in Kanto and Goldenrod City in Johto. The train doesn't follow a schedule, so you can take it whenever you would like.



3 SAFFRON CITY GYM

The path to Sabrina, Saffron City's Gym Leader, is a bit confusing. There are many warp pads to step on that will lead you around the nine small rooms, many of which have a Trainer inside, waiting to battle. To reach Sabrina, step on the warp pads in this order: A, B, C, D, O.

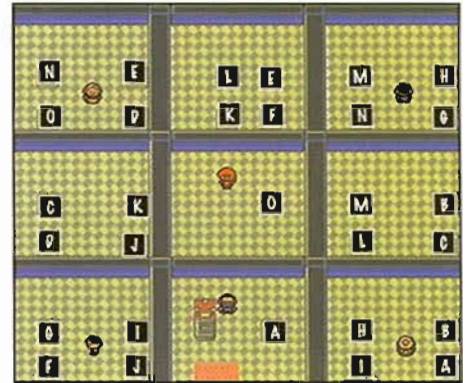

SAFFRON CITY GYM LEADER: SABRINA

Sabrina uses Psychic-types. If you have Dark-type Pokémon with Psychic-type attacks, you will easily prevail. You can find Dark-types on Route 7—raise them to Level 40 or higher before attempting to battle.

RECOMMENDED POKÉMON TYPES:

DARK, PSYCHIC, ELECTRIC, ICE, ROCK

PRIZE: MARSH BADGE



Route 8

Route 8 is another short road. It connects Saffron City with Lavender Town. The building used to house the Underground Path, which connected Route 8 with Route 7, but it's been closed.

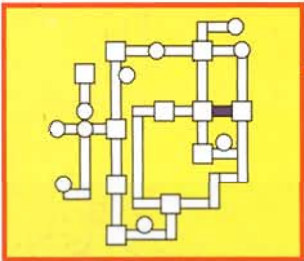

SAFFRON CITY
page 64

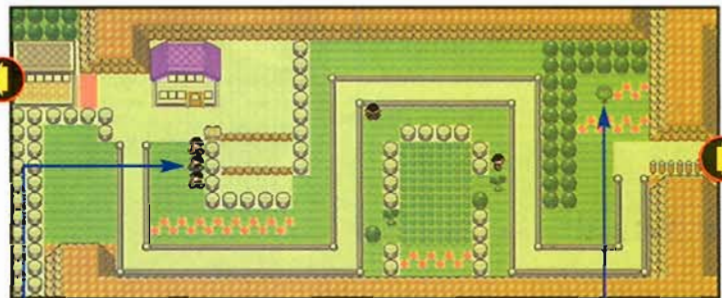

LAVENDER TOWN
page 66

The Kantō Pokémon Association is made up of a bunch of thugs that attack with mostly Poison- or Fire-type Pokémon.

PARALYZECURE BERRY

#58 GROWLITHE TYPE: FIRE

The furry Fire-type does extremely well with Fire-type attacks, but don't overload the creature with the hot stuff. Give it one or two non-Fire-type attacks.

FIRE STONE #59 ARCANINE FIR

Attacks

TAKE DOWN
FLAME WHEEL
FLAMETHROWER
EXTREME SPEED #59

HMs

NONE



#52 MEOWTH TYPE: NORMAL

The catlike creatures Meowth and Persian are Normal-type Pokémon with decent special attack power. Meowth can be caught in Pokémon Blue and Pokémon Silver, while Persian can be caught only in Pokémon Silver.

LEVEL 28 #53 PERSIAN NRM

Attacks

BITE
PAY DAY
FAINT ATTACK
SLASH

HMs

NONE



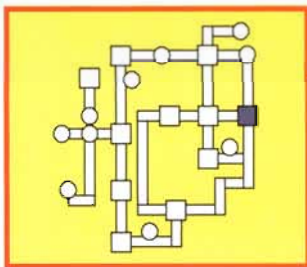

Lavender Town

The large building in Lavender Town houses a Radio Station, and the smaller building nearby is a memorial for the souls of departed Pokémon. The Radio Station isn't working because the Power Plant isn't operational.

1 RADIO, RADIO EXPANSION CARD

To be the sound's salvation, you need to get the Power Plant up and running. When the power is restored, you'll get a nice gift from the Radio Station's head honcho.

Later: After the Power Plant mess has been fixed up, talk to the Radio Station's President. He will give you an Expansion Card which allows you to listen to the Radio in Kanto. You can go back to Vermilion City and move the Snorlax blocking Diglett's Cave if you tune in to the Poké Flute channel on your Pokégear.

POKÉMON MART

GREAT BALL	600
POTION	300
SUPER POTION	700
MAX REPEL	700
ANTIDOTE	100
PARALYZE HEAL	200
AWAKENING	250
BURN HEAL	250

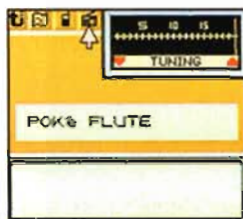
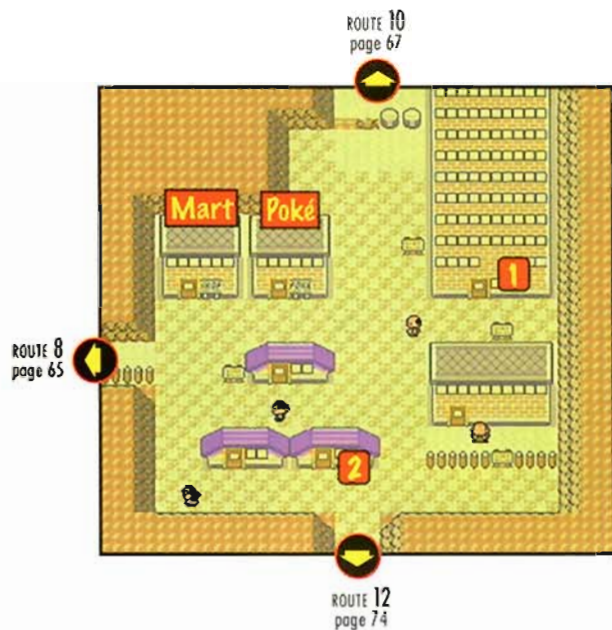

2 ANOTHER RATER

The Name Rater in Lavender Town can help you change your Pokémon's nicknames, just like the Name Rater in Goldenrod City. Remember, though—you can't change the names of Pokémon you received in a trade.



#127 PINSIR TYPE: BUG

The Bug-type brawler, Pinsir, has the brute force necessary to power a move like Strength and the claws to get away with Cut. Teach your Pinsir Swords Dance to raise its Attack Power.

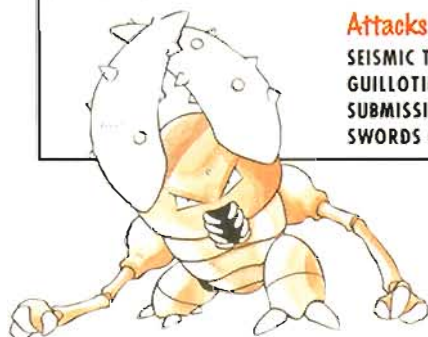

Attacks	HMs
SEISMIC TOSS	CUT
GUILLOTINE	STRENGTH
SUBMISSION	
SWORDS DANCE	

#43 ODDISH TYPE: GRASS/POISON

Oddish has a new evolution in Gold and Silver—Bellossom. All of the Evolution Stones, including the Leaf Stone and the Sun Stone, are pretty rare, so choose your moves very carefully.

LEVEL 21	#44 GLOOM	GRS/PSN
LEAF STONE	#45 VILEPLUME	GRS/PSN
SUN STONE	#182 BELLOSSOM	GRS

Attacks
STUN SPORE
SLEEP POWDER
MOON LIGHT (#43, 44)
PETAL DANCE (#43, 44)
SOLARBEAM

HMs
CUT
FLASH

Depending on your whim, you can raise your Gloom into a Vileplume or a Bellossom, which is new to Gold and Silver. Note that Bellossom is a pure Grass-type, unlike Oddish.

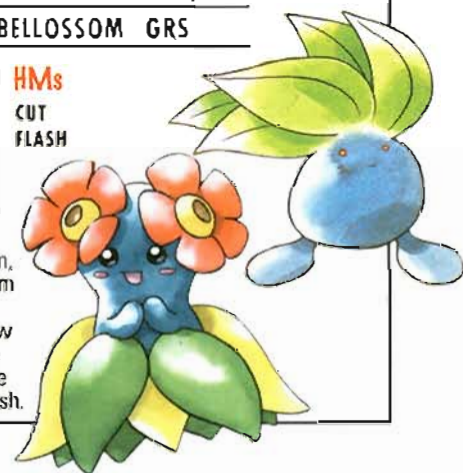

#132 DITTO TYPE: NORMAL

Ditto is a curious creature that has just one attack—Transform. With it, Ditto can become a seemingly exact replica of its opponent. Ditto's stats do not change, so if your Ditto is weak, the attacks it uses in its new form will be weak, too.

Attacks	HMs
TRANSFORM	NONE

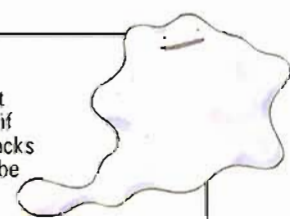

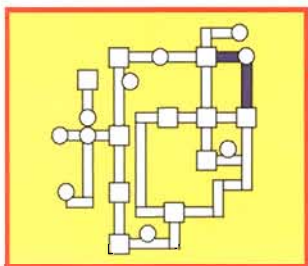

Route 9 & Route 10

The Power Plant is located in the middle of Route 10—you have to go through the Rock Tunnel, then up Route 10 to the water, where you can Surf back down Route 10 to the building as shown by the white arrow on the map. Assess the situation at the Power Plant and try to fix it, or you won't get much farther.

1 POWER OUTAGE

Talk to the Power Plant's manager and the Police Officer inside the Power Plant to learn about the Power Plant's missing part. Go out to Cerulean City's Gym, where you will run into a suspicious man who definitely knows where the part is. See page 68 for more information.



CERULEAN CITY page 68

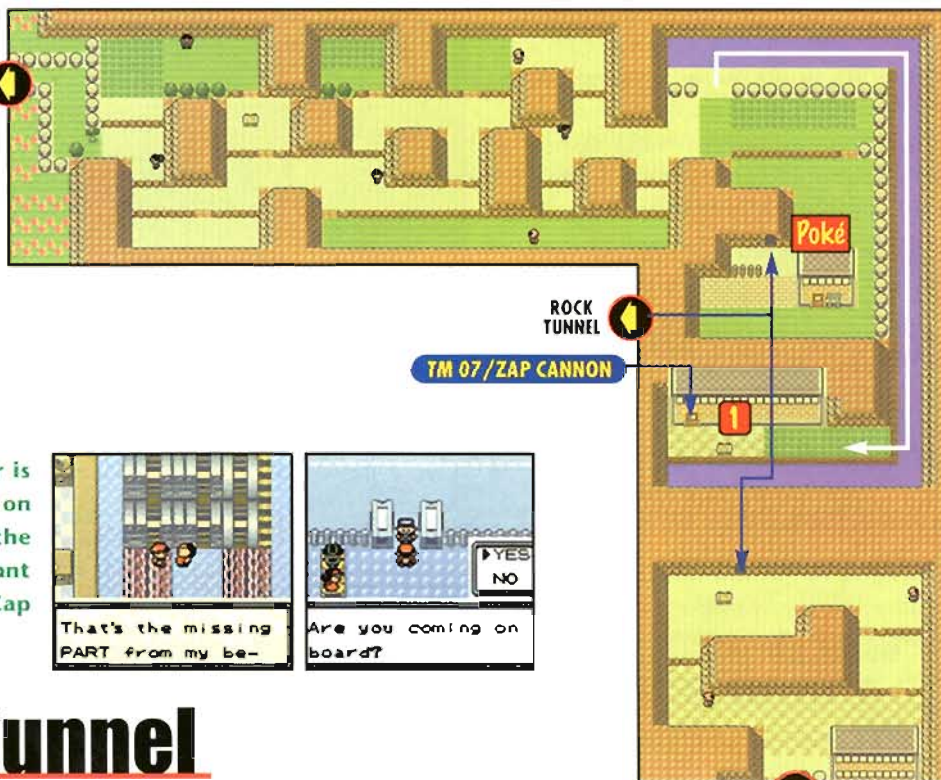

ROCK TUNNEL

TM 07/ZAP CANNON

LAVENDER TOWN page 66

Later: After the part is returned and the power is restored, everything in Kanto that depends on electricity will start working again, including the train that travels from Kanto to Johto. The Plant Manager will also reward you with TM 07, Zap Cannon, to thank you for your help.

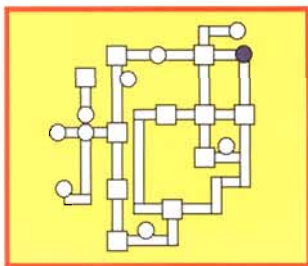

Rock Tunnel

The Rock Tunnel will get you from Lavender Town to Route 10. It is neither complex nor large, so you shouldn't have trouble picking up all the items inside and finding your way out. Make sure you pick up TM 47, Steel Wing, when you first enter the tunnel.

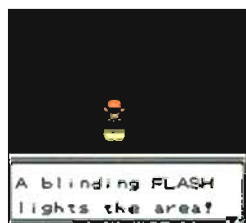

Bring along a Pokémon that knows Flash to illuminate the interior of the Tunnel.

TM 47/STEEL WING

ELIXIR

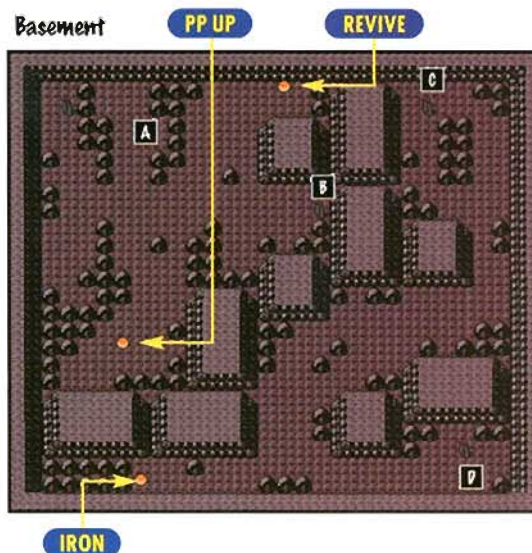
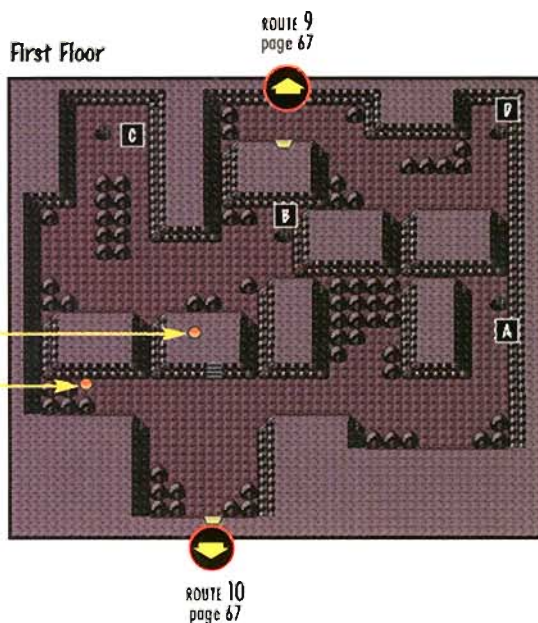

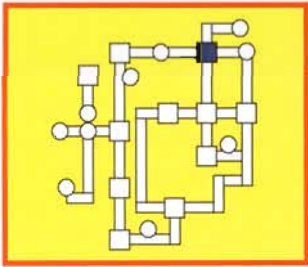

Cerulean City

Head directly to the Gym to find the suspicious man who has run off with the Power Plant's part. The Gym Leader isn't in the Gym, but that's OK—you have other business to attend to before you battle with her.

1 SOMETHING SUSPICIOUS

The man standing outside the Gym is a good source of information. He will help you find the suspicious man and Misty.



2 CERULEAN CITY GYM

You won't be able to battle the Gym Leader until you take care of the Power Plant situation. Tackle the odd, suspicious man first, then head up to Route 25 to get the Gym Leader, Misty, back to the Gym.



Later: Find the odd man up at Route 24, then battle and defeat him. He will admit that he threw the machine part into the water in Cerulean City's Gym. Use your Item Finder to locate the missing part, which is located in the square pool in the center of the Gym.

This man's Item Finder is going off. Surf in the water near where he is standing to pick up the item.



This building used to house a Bike Shop, but a sign posted out front informs you that the shop has moved to Johto.



POKÉMON MART

GREAT BALL	600
ULTRA BALL	1,200
SUPER POTION	700
SUPER REPEL	500
FULL HEAL	600
X DEFEND	550
X ATTACK	500
DIRE HIT	650
SURF MAIL	50

CERULEAN CITY GYM LEADER: MISTY

Misty prefers Water-type Pokémon, but some of her creatures have dual-types like Water-and-Ice or Water-and-Psychic. If you have both an Electric-type and a Grass-type, you won't have any problems defeating her.

RECOMMENDED POKÉMON TYPES:

ELECTRIC, GRASS

PRIZE: CASCADE BADGE

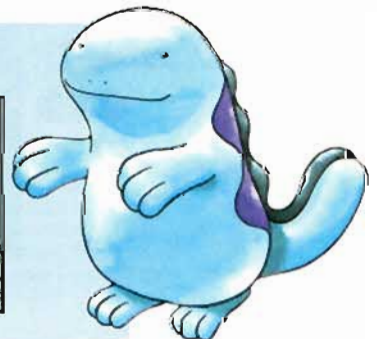

Route 24 & Route 25

Route 24 and Route 25 aren't that long, but there is a lot to see and do there. You'll have plenty of battles to fight, a machine part to track down, and a Gym Leader to find.

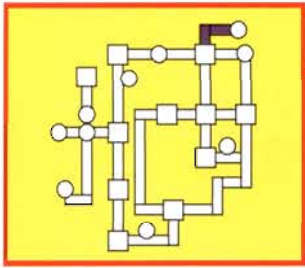

PROTEIN **NUGGET**

There are many Trainers along Route 25, and if you beat them all, you'll get a Nugget for your trouble.

2 DATE CRASHER

After you've confronted the odd man and retrieved the machine part, head back up to the docks, where Misty has gone on a date. She'll go back to the Gym once you've interrupted her romantic stroll along the water, and she'll be ready to fight!



OK, then. Come to CERULEAN GYM.

1 ROCKET REDUX

You'll come to a poor, odd fellow who's a member of Team Rocket—but Team Rocket is no more! He hasn't gotten the news of Team Rocket's demise yet, so you'll have to put him in his place. After you defeat him, he will tell you where he hid the missing machine part, so you can retrieve it and fix the generator at the Power Plant.

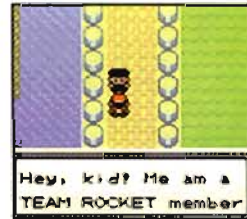

3 BILL'S GRANDFATHER

EVERSTONE **FIRE STONE** **LEAF STONE**
THUNDER STONE **WATER STONE**

Bill's grandfather will ask you to show him a Pokémon with a long tongue. If you have such a Pokémon, Bill's grandfather will give you an Everstone. Come back often—Bill's grandfather will ask to see different Pokémon, and he'll have many stones to reward you with.



#48 VENONAT TYPE: BUG/POISON

Venonat is not a powerhouse Pokémon, but as a Bug-and-Poison-type, it does well with attacks that poison or put to sleep other Pokémon. You can use the Pokémon to really bug other Trainers.

LEVEL 31 #49 VENOMOTH BUG/PSN

Attacks
POISON POWDER
STUN SPORE
SLEEP POWDER
PSYCHIC

HMs
FLASH (#49)

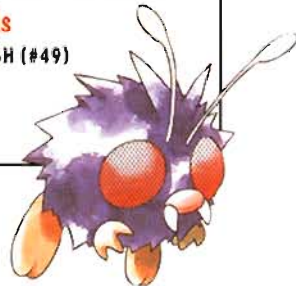

Route 5

Head south from Cerulean City on Route 5 to reach the house in the center of the route. The old woman in the house will give you Cleanse Tag, which will keep wild Pokémon away from you.

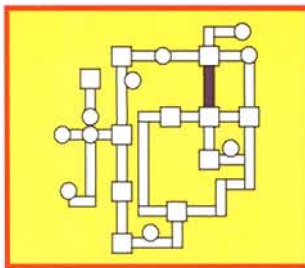

SAFFRON CITY
page 64

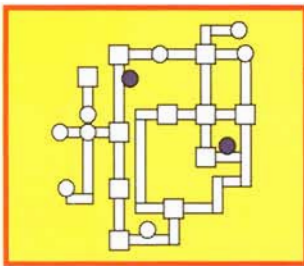

Diglett's Cave

Diglett's Cave couldn't be much simpler. It's basically a way to get from Vermilion City to Route 2. You can catch Diglett in the cave, which is great. You won't be able to enter the cave until you wake up Snorlax.



ROUTE 2
page 75



VERMILION CITY
page 63

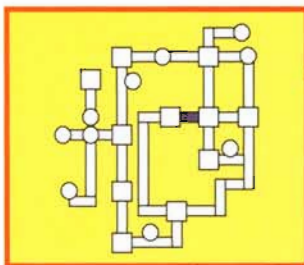
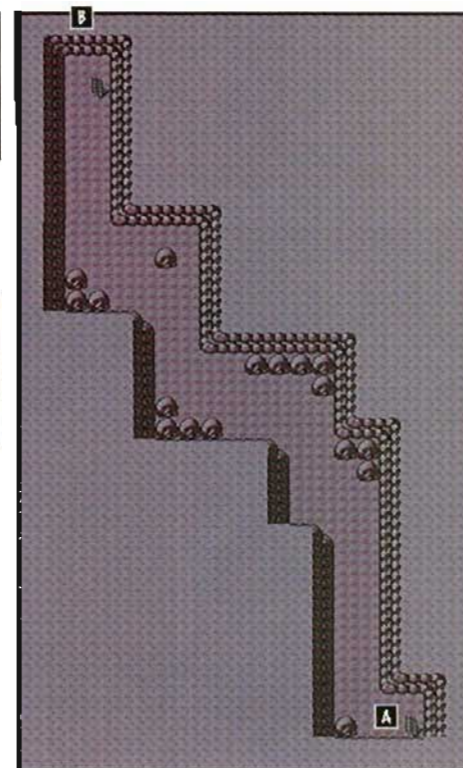

Route 7

Route 7 is another supershort road that connects two cities—Celadon City and Saffron City. The building used to house an entrance to an Underground Path that led to Route 8, but it's been closed off because of unruly Trainers.

CELADON CITY
page 71



SAFFRON CITY
page 64

#37 VULPIX TYPE: FIRE

Vulpix is a fiery little rascal that does better in battle when it has a few attacks that protect it and a few attacks that heat things up. Vulpix evolves into Ninetales with the help of a Fire Stone.

FIRE STONE #38 NINETALES FIR

Attacks

QUICK ATTACK
CONFUSE RAY
SAFEGUARD
FLAMETHROWER

HMs

NONE



#198 MURKROW
TYPE: DARK/FLYING



#228 HOUNDOUR TYPE: DARK/FIRE

Celadon City

Like Goldenrod City in Johto, Celadon City is a very large place, featuring a department store and a game arcade. Celadon Mansion is home to GAME FREAK, the creators of the Pokémon games. Stop in and talk to them for some interesting conversation.

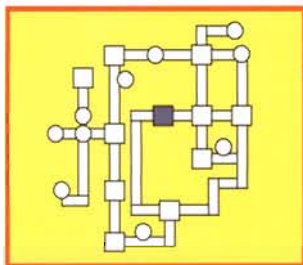

POKÉMON MART

2nd Floor-1

POKé BALL	200
GREAT BALL	600
ULTRA BALL	1,200
ESCAPE ROPE	550
FULL HEAL	600
ANTIDOTE	100
BURN HEAL	250
ICE HEAL	250
AWAKENING	250
PARALYZE HEAL	200

2nd Floor-2

POTION	300
SUPER POTION	700
HYPER POTION	1,200
MAX POTION	2,500
REVIVE	1,500
SUPER REPEL	500
MAX REPEL	700

4th Floor

POKé DOLL	1,000
LOVELY MAIL	50
SURF MAIL	50

5th Floor-1

X ACCURACY	950
GUARD SPEC.	700
DIRE HIT	650
X ATTACK	500
X DEFEND	550
X SPEED	350
X SPECIAL	350

5th Floor-2

HP UP	9,800
PROTEIN	9,800
IRON	9,800
CARBOS	9,800
CALCIUM	9,800

3rd Floor

TM 10/HIDDEN POWER	3,000
TM 11/SUNNY DAY	2,000
TM 17/PROTECT	3,000
TM 18/RAIN DANCE	2,000
TM 37/SAND STORM	2,000

6th Floor

FRESH WATER	200
SODA POP	300
LEMONADE	350

1 GAME FREAK TM 03/CURSE

The fine people who created Pokémon are working in Celadon Mansion. You can talk to the Programmer, the Game Designer, the Graphic Artist and another fellow who keeps his job title to himself. Wait until dark, then take the path behind the mansion to reach the fourth floor and talk to the man inside. He will tell you a scary story about a bicycle, then he will give you TM 03, Curse.



ROUTE 16
page 72

ROUTE 7
page 70

LEFTOVERS

They're having an eat-a-thon in the restaurant, but you can't enter. Check the area around the garbage can for Leftovers, which restore HP to Pokémon in battle.

2 TAKE A CHANCE COIN x18

Talk to everyone inside the Game Corner—one man will give you 18 coins to take your chances with. The Game Corner has slot machines similar to the machines in Goldenrod City and good prizes for those lucky enough to win big.

PRIZE

TM 32/DOUBLE TEAM	1,500
TM 29/PSYCHIC	3,500
TM 15/HYPER BEAM	7,500
#122 MR. MIME	3,333
#133 EEEVEE	6,666
#137 PORYGON	9,999



3 CELADON CITY GYM

Make sure you have a Pokémon with you that can use cut, so you can eliminate the single obstacle blocking the way to Celadon City's Gym. Inside the Gym, you might run into some of Erika's followers, but, like their Leader, they're using mostly Grass-type Pokémon. They won't give you much trouble, because you're already carrying a Fire-type and an Ice-type to deal with Erika. Heal your Pokémon before facing Erika if necessary.



CELADON CITY GYM LEADER: ERIKA

Erika is a big fan of Grass-types, which means you should be a big fan of Fire-types and Ice-types when you battle her. Watch out for her tough attacks, like Solarbeam, which could put the hurt on your team. If you attack quickly with your most powerful Fire- or Ice-type attacks, you'll do very well.

RECOMMENDED POKÉMON TYPES:

FIRE, ICE, PSYCHIC

PRIZES: RAINBOW BADGE/TM 19 (GIGA DRAIN)

Giga Drain will give your attacking Pokémon a boost in HP equal to half the amount of damage the attack inflicts upon the opposing Pokémon.

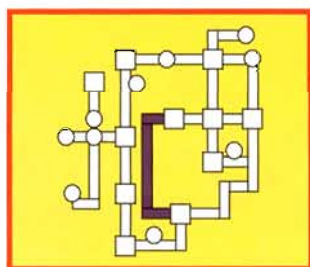
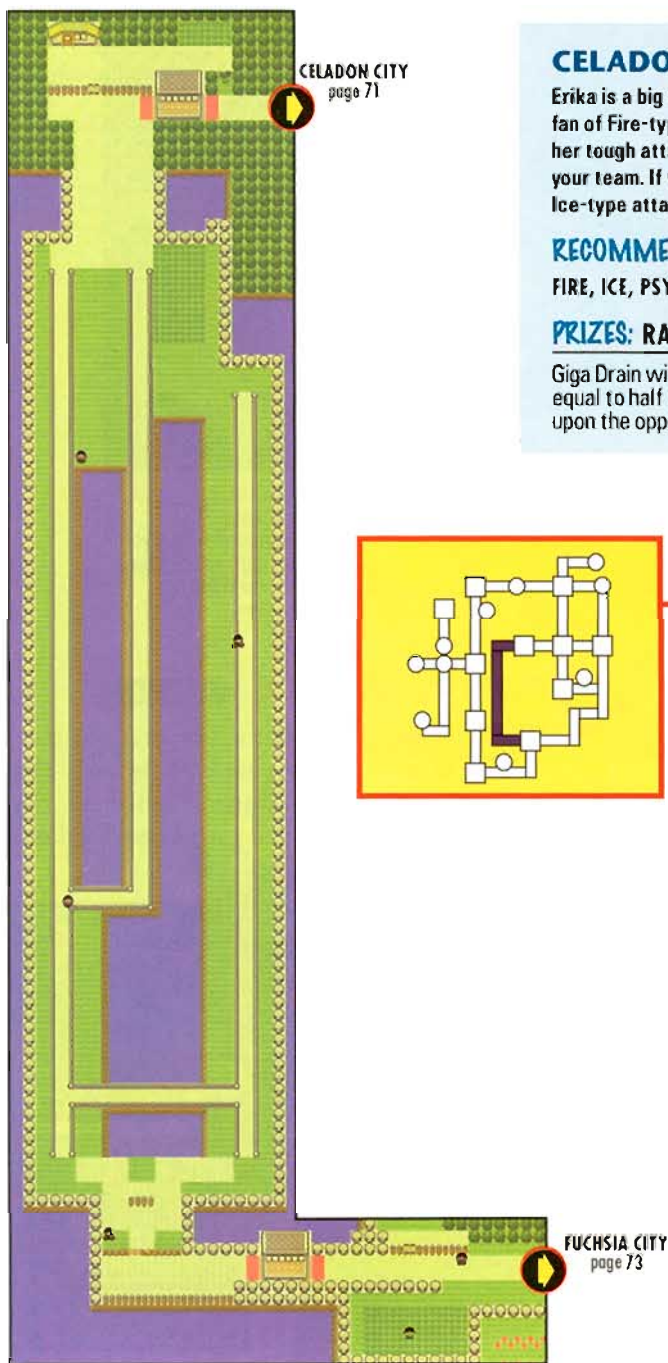

Routes 16, 17 & 18

Route 16 is short and leads to Route 17, which is a Bike Path. Once you start going downhill, you will keep going, even if you stop pushing Down on the Control Pad. You can stop to fish, but otherwise you have to move up or down the hill constantly. Route 18 is not downhill, so you can stop wherever you want to.

#88 GRIMER TYPE: POISON

Grimer and Muk seem to be two slithering blobs of toxic sludge, and their Poison-type does nothing to dispel that image. The two poisonous pals have quite a bit of HP on their sides, and Muk in particular has fabulous attack

LEVEL 38 #89 MUK PSN

Attacks

SLUDGE
MINIMIZE
ACID ARMOR
SLUDGE BOMB

HMs

NONE



Fuchsia City

Fuchsia City has seen some changes since the first Pokémon games. The Safari Zone is closed because the director is traveling abroad. Koga, the former Gym Leader, is now part of the Elite Four. There's also some construction going on in the city, which will keep you from Cinnabar Island for a short time.

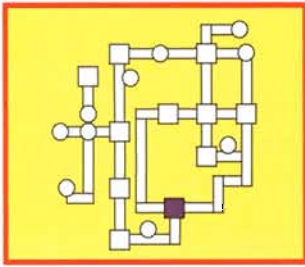

The world-famous Safari Zone is closed, because its director has gone on a much-needed vacation. He won't be back.

1 ROAD CLOSING

You can't take the road to Route 19 as you might like, so if you want to get to Cinnabar Island, you'll have to go around the other way,



through Pallet Town. The construction will be completed when you reach Cinnabar from the other direction.

2 FUCHSIA CITY GYM

Koga's daughter, Janine, is the new Fuchsia City Gym Leader. She has taught her Trainers well in the art of disguise, and each one of them appears to be Janine when you meet them. When the battle starts, however, you will see that it's not Janine you're fighting.



FUCHSIA CITY GYM LEADER: JANINE

Janine prefers Poison-type Pokémon, so you should protect yourself with Psychic-, Ground-, and Fire-type Pokémon. In addition to the Soul Badge, Janine will give you the poison-friendly TM 06, Toxic, when you beat her.

RECOMMENDED POKÉMON TYPES:

PSYCHIC, GROUND, FIRE

PRIZES: SOUL BADGE/TM 06 (TOXIC)

POKÉMON MART

GREAT BALL	600
ULTRA BALL	1,200
SUPER POTION	700
HYPER POTION	1,200
FULL HEAL	600
MAX REPEL	700
FLOWER MAIL	50

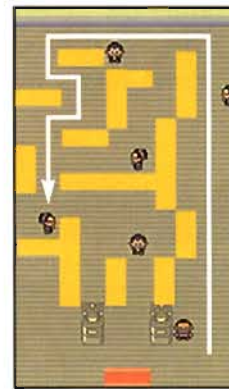

Follow the arrow's path to find the true leader of Fuchsia City's Gym. You will find it hard to walk around the Gym—there are tiny, almost invisible walls that force you into the paths of many of the Trainers.



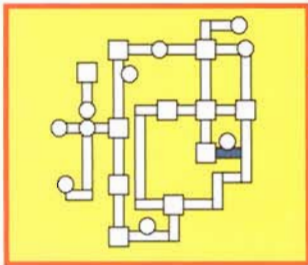

Route 11

After you've cleared Snorlax out of the way in Vermilion City, you can take Route 11 to Route 12. There are a few Trainers to battle and lots of tall grass full of Pokémon. The Trainers are using Flying-, Grass- or Fire-type Pokémon, so be prepared to battle those types.

#46 DROWZEE TYPE: PSYCHIC

The sleepy little Psychic-type, Drowzee, evolves into the entrancing Hypno at level 26. The two creatures can't go wrong with the attack that seems custom-built for them, Hypnosis. Psychic is also perfectly suited to any Psychic-type.

LEVEL 26 #97 HYPNO PSY

Attacks

HYPNOSIS
HEADBUTT
MEDITATE
PSYCHIC

HMs

NONE



VERMILION CITY
page 63

ROUTE 12
page 74

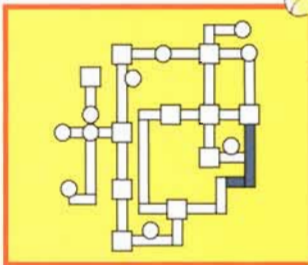

Route 12 & Route 13

If you're in the mood for Trainer battles, Routes 12 and 13 are definitely the places to be. There are many Trainers ready to do battle with you along the routes, and they have a great variety of Pokémon types—take a well-balanced team on your trip!

#113 CHANSEY TYPE: NORMAL

The large and in charge Normal-type, Chansey, is a very versatile creature, capable of learning an astonishing number of attacks from TMs and HMs. The pear-shaped pink one has a new evolution, Blissey, in Gold and Silver but Chansey won't evolve if it's not very attached to its Trainer.

SEE PG.92 #242 BLISSEY NRM

Attacks

SOFTBOILED
EGG BOMB
LIGHT SCREEN
DOUBLE-EDGE

HMs

NONE



1 TAKE THE BAIT SUPER ROD

If you talk to the man in the cabin about fishing, he will give you the Super Rod, which allows you to catch Water-type Pokémon at much higher levels in the rivers, lakes and seas you encounter on your journey.



Surf in the water off Route 12, then cut the tree and walk up to the item on the ground—Nugget!

ROUTE 11
page 74

LAVENDER TOWN
page 66



Route 14 & Route 15

Routes 14 and 15 also have plenty of Trainers waiting to battle you. Take along a few items that will keep your Pokémon strong for the entire journey.

1 A CHANSEY OPERATION

Cut down the tree blocking the way to reach the girl in the grass. She is willing to trade her Aerodactyl, the only one in the game, for your Chansey. Not a bad trade-off, even if it does take you a long time to find a Chansey to trade.

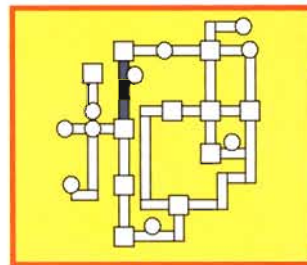
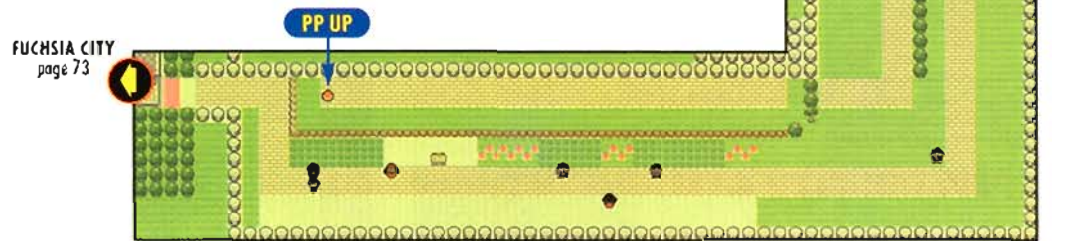

Route 2

There are many trees along Route 2—if you want to see everything the route has to offer, you'd better bring a Pokémon that knows Cut with you.

#25 PIKACHU TYPE: ELECTRIC

Pikachu is astonishingly popular, and given its powerful Electric-type, it's not surprising. It was recently discovered that Pikachu is a Pokémon that has evolved already—if you'd like to meet Pikachu's predecessor, take two Pikachu to the Pokémon Daycare.

THUNDER STONE #26 RAICHU ELC

Attacks	HMs
THUNDER WAVE	FLASH
QUICK ATTACK	
THUNDERBOLT	
THUNDER	



#163 HOOTHOOT TYPE: NORMAL/FLYING

Hoothoot is a night owl, and you won't be able to catch it during the day. After 6 p.m., however, you can catch one.

Attacks	HMs
FORESIGHT	FLY
HYPNOSIS	
TAKE DOWN	
DREAM EATER	

LEVEL 20 #164 NOCTOWL NRM/FLY



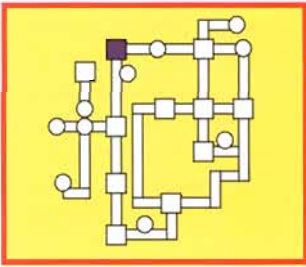

Pewter City

Pewter City has the item you need to find whichever Legendary Bird you haven't caught yet—Ho-oh in Silver, or Lugia in Gold. Brock, the Gym Leader who prefers Rock-type Pokémon, lives in Pewter City.

1 WINGING IT

You can finally pick up either the Rainbow Wing (Silver) or the Silver Wing (Gold) in Pewter City. Talk to the old man, to get the Wing he found while training in Johto a long time ago. After you get one of the Wings, head to the Tin Tower (Silver) to catch Ho-oh or Whirl Island (Gold) to catch Lugia.



2 PEWTER CITY GYM

Brock and his single Trainer use mostly Rock- and Ground-type Pokémon. There are no surprises in the Gym, but there are stone-cold Pokémon battles.

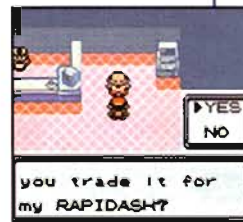
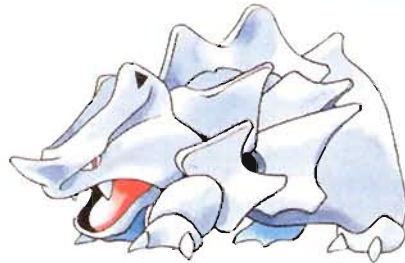

ROUTE 2
page 75

If you have a Gloom, you can trade it to the man in the Pokémon Center for a Rapidash.



ROUTE 3
page 77

POKÉMON MART

GREAT BALL	600
SUPER POTION	700
SUPER REPEL	500
ANTIDOTE	100
PARALYZE HEAL	200
AWAKENING	250
BURN HEAL	250

PEWTER CITY GYM LEADER: BROCK

The battle against Brock will be easy if you take along a good Water-type Pokémon or two and a Grass-type Pokémon. Brock's Pokémon are very tough, but your Water-types should sail right through the battle.

RECOMMENDED POKÉMON TYPES:

WATER, GRASS

PRIZE: BOULDER BADGE



Route 3

Route 3 leads to Mt. Moon, where your Rival is waiting, ready to battle. You'll run into a handful of Trainers with Flying-, Poison- or Fire-type Pokémon, so you might want to backtrack to Pewter City before continuing on to Mt. Moon.

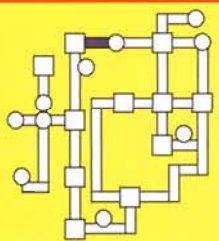

PEWTER CITY
page 76

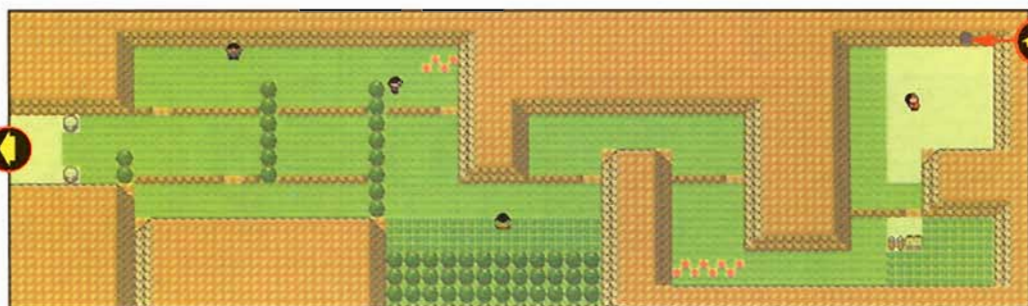

MT. MOON
page 77

Mt. Moon

Situated directly between Routes 3 and 4, Mt. Moon is a small but important part of Kanto. It's the only place you can catch the elusive Clefairy, but you might have to stick around all night before one shows up!



RIVAL! BATTLE 5



When you enter Mt. Moon, your Rival will immediately come up to you and challenge you to a battle. His Pokémon haven't changed from the last time you saw him, but every one of his creatures is over Level 40. Try to have several Pokémon over Level 40 as well.

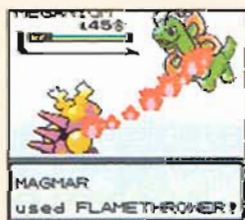

RECOMMENDED POKÉMON TYPES:

FIRE, GROUND, PSYCHIC

1 CLEFAIRY'S DANCE

Every Monday night, Clefairy does a pretty little dance in the square. Pay attention to the rock it dances around—if you break it immediately with Rock Smash, you could find something really cool! If you don't



have Pokémon with Rock Smash at the time you won't be able to return to pick it up.

First Floor

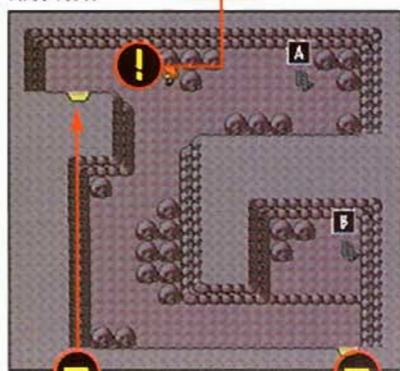

ROUTE 3
page 77

ROUTE 4
page 78

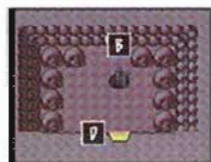

The Pokémon Mart at Mt. Moon has several items that are regularly sold in department stores only, like Lemonade and Poké Dolls. It also sells a new kind of stationery, Portrait Mail.

POKÉMON MART

POKÉ DOLL	1,000
FRESH WATER	200
SODA POP	300
LEMONADE	350
REPEL	350
PORTRAIT MAIL	50

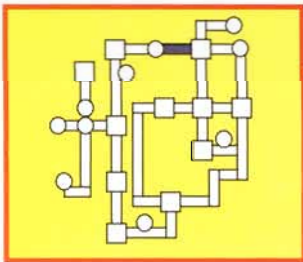

Route 4

Route 4 is a sort of one-way street—you can go from Mt. Moon to Cerulean City, but you can't do the opposite because of the small cliffs that make up the route. Only a few Trainers will challenge you on Route 4.

#39 JIGGLYPUFF TYPE: NORMAL

Jigglypuff evolves with the Moon Stone, making it a perfect candidate for capture in one of Kurt's specialty Poké Balls, the Moon Ball. Take a Yellow Apricorn to Kurt in Azalea Town—in one day you'll have the perfect ball to capture Jigglypuff!

MOON STONE #40 WIGGLYTUFF NRM

Attacks

SING
ROLLOUT
REST
BODY SLAM

HMs

NONE

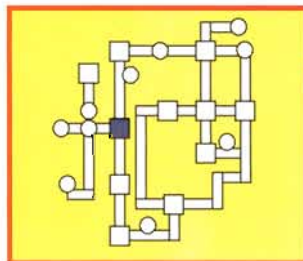
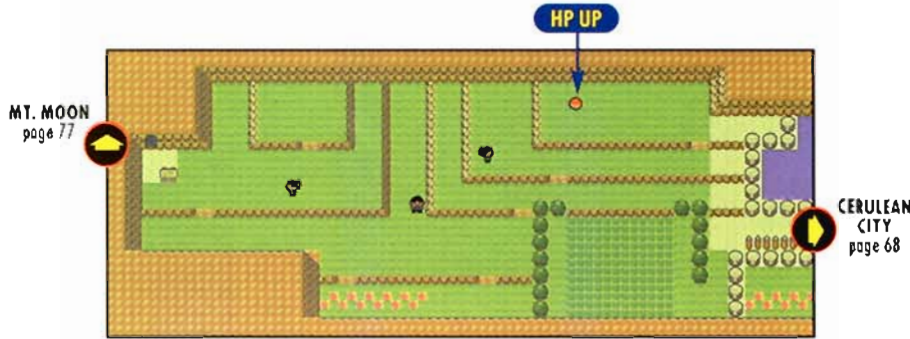

Viridian City

The first time you wander up to Viridian City, you probably won't be able to find the Gym Leader, Blue. Talk to everyone in the city to learn that there's a clue to the Gym Leader's whereabouts on Cinnabar Island.

1 A BATTLE A DAY

The Trainer House in Viridian City is a good place to train. You can participate in a battle there once a day. If you've recently exchanged Mystery Gifts with someone, that person will

be the Trainer you face in the Trainer House. Otherwise, you'll battle a Trainer that has three Level-50 Pokémon: Meganium, Typhlosion and Feraligatr. You can fight only one battle a day, so make it count!



2 VIRIDIAN CITY GYM

You won't see anybody inside the Viridian City Gym the first time you pass through. You have to head up to Route 1, across Pallet Town and down to Cinnabar Island, where you'll find Blue.

Later: After you've made it to Cinnabar Island and talked to Blue, he will head back to Viridian City Gym so you can fight him. He is a formidable opponent—make sure your Pokémon are battle-ready before you challenge him.



VIRIDIAN CITY GYM LEADER: BLUE

Blue has a terrific team of Pokémon covering many different types. Bring along a team with several Pokémon at or above Level 50, or you might not make it through the battle. Use basic type matching to defeat Blue's team.

RECOMMENDED POKÉMON TYPES:

DARK, ELECTRIC, FIRE, GROUND, WATER

PRIZE: EARTH BADGE

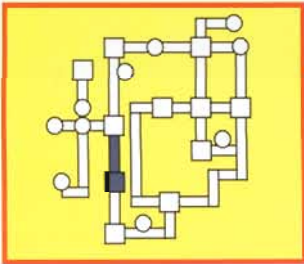

Pallet Town & Route 1

The current Pokémon Champ, Red, is from Pallet Town, as is Blue and his grandfather, Professor Oak. Red is off on a trip, so you won't be able to challenge him just yet. You can visit Professor Oak in his lab, if you'd like.

1 HOUSE OF BLUE'S

Blue, Viridian City's Gym Leader, is from Pallet Town, and his sister still lives there. If you visit Blue's House from 3 p.m. to 4 p.m., Blue's sister will groom one of your Pokémon. Pokémon love being taken care of and prettied up, and if you groom them often,

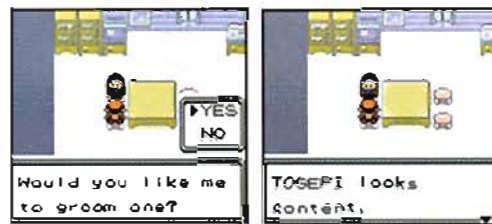

they will become more attached to you. You have to visit the house at that specific time, however, or Blue's sister won't work on your Pokémon. You can have only one Pokémon groomed per day.

2 THE PROFESSOR IS IN

Visit Professor Oak's lab to touch base with the Pokémon professional. You can show him your Pokédex and get his evaluation of it on the spot. Professor Oak is interested to learn that you are collecting Kanto Badges. He asks you to return once you've collected all eight of the badges.

Later: Return to the Professor's lab after you've collected all eight Kanto Badges. Professor Oak will grant you permission to enter Mt. Silver through the Pokémon League reception gate on Route 26. That's just what you need—a new area to explore!



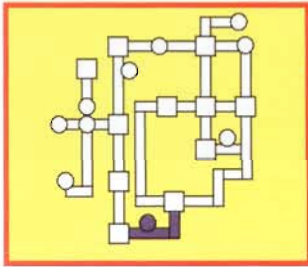

Cinnabar Island, Seafoam Island, Route 19, Route 20 & Route 21

A volcano eruption has devastated Cinnabar Island, leaving little standing save the Pokémon Center. Even the Gym was destroyed! The Gym Leader, Blaine, moved the Cinnabar Island Gym to Seafoam Island, which is nearby. If you want the badge, you'll have to keep going.

1 BLUE AWAY

You'll meet up with Blue on Cinnabar Island. He's come to check out the damage caused by the lava, and it's clear that he feels a bit depressed about all of the destruction. He will return to Viridian City Gym after talking to you. Don't take off after him—head to Seafoam instead.



2 CINNABAR/SEAFOAM GYM

Blaine moved the Cinnabar Island Gym to Seafoam Island after the volcano erupted. Surf to Seafoam Island to find Blaine in the cavelike Gym. Afterward, you can Surf across Routes 19 and 20 to Fuchsia City.



3 THE ROAD LESS TRAVELED

When you visited Fuchsia City earlier, you couldn't get to Cinnabar Island because of construction work. After you approach the road from the Cinnabar side, the work will be completed and you'll be able to go back and forth between Fuchsia City and Cinnabar Island.

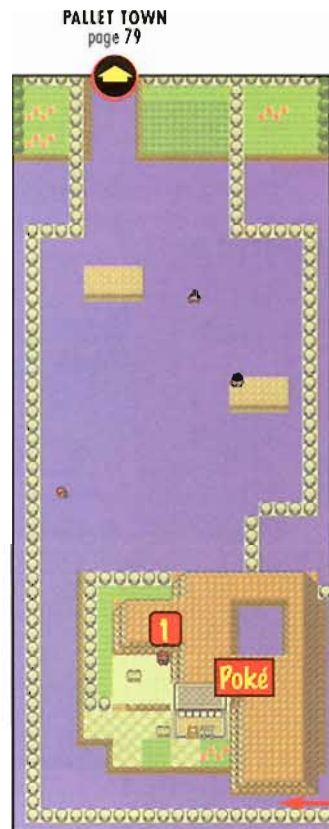

SEAFOAM ISLAND GYM LEADER: BLAINE

Blaine uses mainly Fire-type Pokémon, so a combination of Water-, Ground- and Rock-types will easily extinguish Blaine's flames. Blaine is a crafty Trainer, and he might surprise you with some of his attacks.

RECOMMENDED POKÉMON TYPES:

WATER, GROUND, ROCK

PRIZE: VOLCANO BADGE

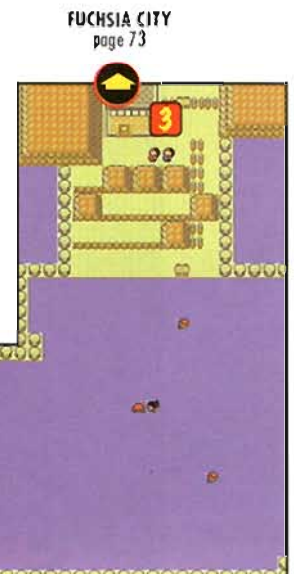
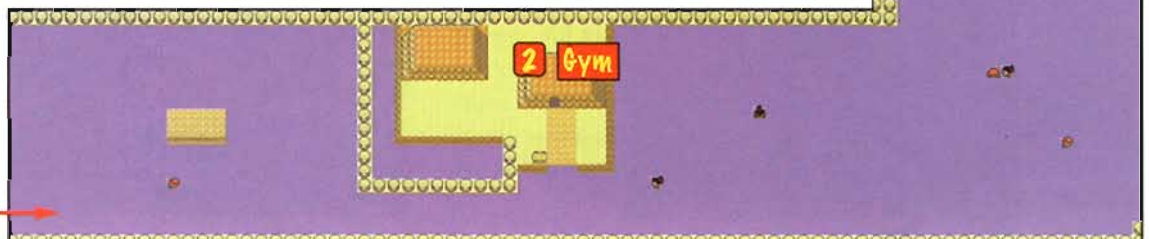
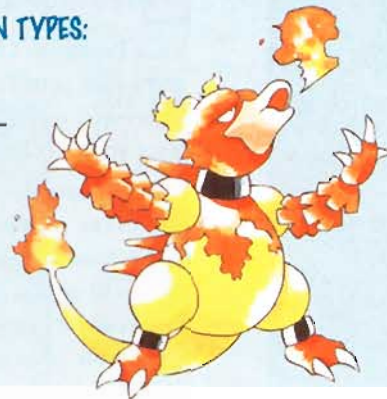

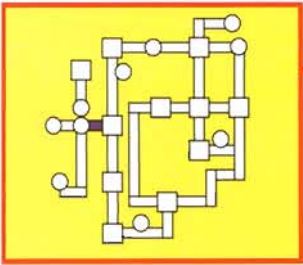

Route 22

Route 22 leads you back to the Pokémon League Reception Gate you passed through earlier on your way to battle the Elite Four. If you talk to Professor Oak after you have all eight Kanto Badges, the person who was blocking the way to Mt. Silver will be gone.

RECEPTION GATE
page 59

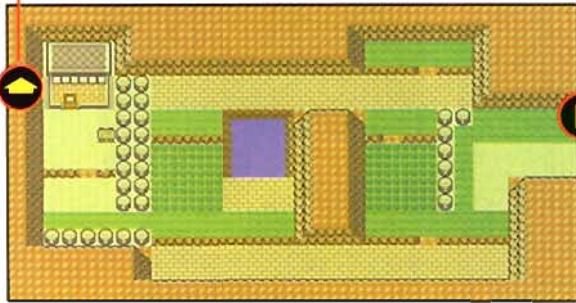

VIRIDIAN CITY
page 78

#60 POLIWAG TYPE: WATER



The smallest Pokémon with the swirls on its tummy is Poliwag, a creature reminiscent of a polywog. Polywogs grow up to be frogs and toads. Could Poliwag have a similar future?

LEVEL 25	#61 POLIWHIRL	WTR
WATER STONE	#62 POLIWRATH	WTR/FTG
SEE PG.90	#186 POLITOED	WTR

Attacks

HYPNOSIS
BODY SLAM (#60, #61)
BELLY DRUM (#60, #61)
SUBMISSION (#62)

HMs

WHIRLPOOL
WATERFALL
STRENGTH (#61, #62)

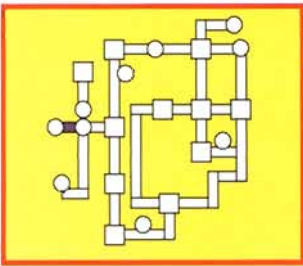

Route 28

Route 28 takes you to Mt. Silver. It is a fairly long road that is not densely populated by Trainers, but it is well-populated with plenty of wild Pokémon in the tall grass. Take a rest at the Pokémon Center before heading up to Mt. Silver.

1 THE FAMOUS RECLUSE TM 47/STEEL WING

The woman in the only house on Route 28 is living out in the middle of nowhere to get away from her fans. She will be very surprised to see you, and she'll generously offer you TM 47, Steel Wing. You should probably leave her alone after you get the TM.



MT. SILVER
page 82

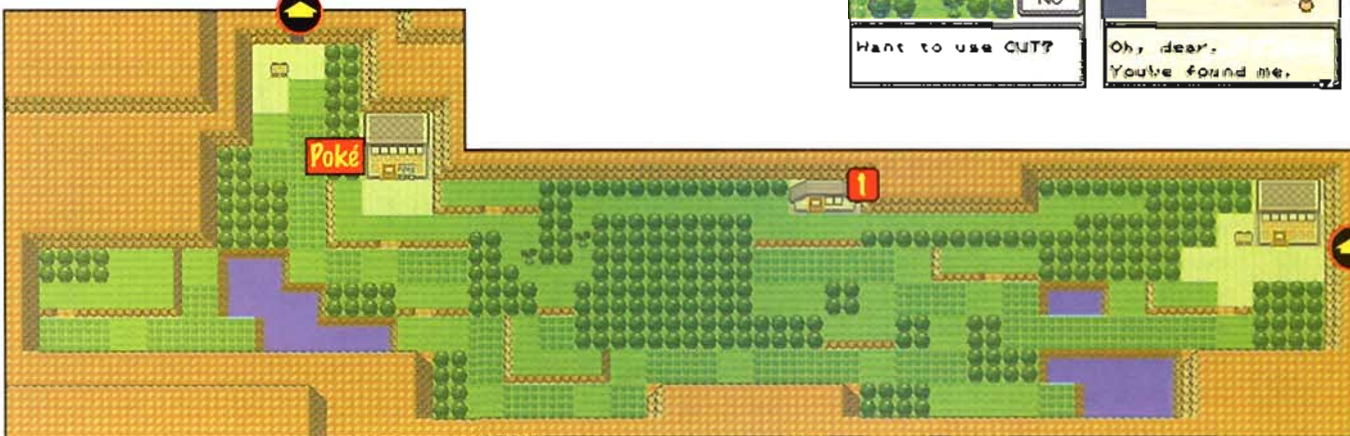

RECEPTION GATE
page 59

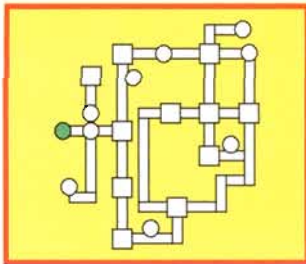

Mt. Silver

If you want to explore the entire interior of Mt. Silver, you'll need to take along Pokémon that know Flash, Surf and Waterfall. The Pokémon inside the mountain are very strong—if you're having trouble with the wild Pokémon, you're definitely not ready for the final showdown with the person waiting at Mt. Silver's summit. Train hard! Mt. Silver is actually in Johto, but you can walk up to it only from Kanto. After you've visited Mt. Silver once, you can fly back to it from Johto.

Second Floor Room 1

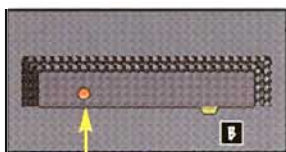

MAX REVIVE

First Floor & Second Floor

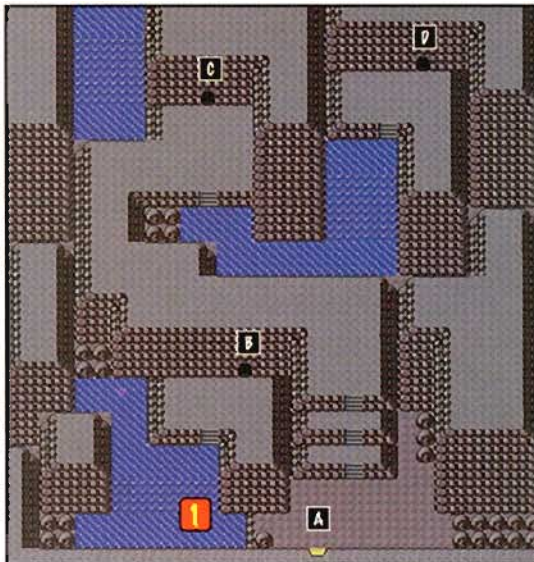

Second Floor Room 2

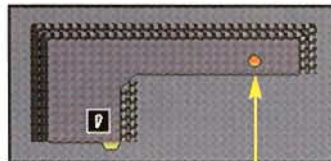

FULL RESTORE

First Floor Room 1

MAX ELIXIR

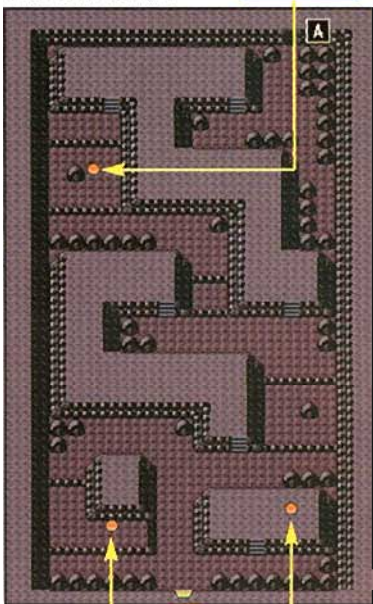

ESCAPE ROPE

X ACCURACY

ROUTE 28
page 81

Second Floor Room 3

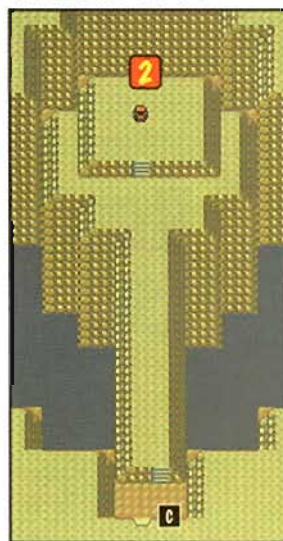

1 CHASING WATERFALLS

There are several places inside Mt. Silver where the only way to progress is to splash up a waterfall. The Pokémon that you've taught Waterfall need not be a hard-battling creature—you're going to need six strong Pokémon to defeat Red, but you don't need Waterfall to reach Red.



2 THE CHAMP

On top of Mt. Silver, you will meet the best Trainer in the land—Red. He is by far the strongest opponent you will face in Pokémon Gold and Silver, and you should not underestimate his powerful, excellently equipped team. You should try to attack his Pokémon with Pokémon-types that his Pokémon are weak against. It's a basic strategy, but in this case, it's the best way to go.



FINAL BATTLE INSIDE MT. SILVER: RED

The central character from Pokémon Red, Blue and Yellow, known in Gold and Silver as Red, is the game's toughest Trainer. His Pokémon are all Level-70 or higher, and many different Pokémon types are represented. Try to attack fast and hard—the longer the match drags on, the lower your chance of winning. Your Pokémon should be Level-50 or higher.



RECOMMENDED POKÉMON TYPES:

DARK, ELECTRIC, FIGHTING, FIRE, GROUND, WATER



Gotta Get 'Em All

There's nothing better than a full Pokédex, but to enjoy that you'll have to catch or collect the wily creatures. Some Pokémon live in the wild, and you can capture them using Poké Balls. Other Pokémon must be evolved, traded or hatched. The following pages describe how you can build the ultimate collection using all of the methods.

WILD THINGS

Most Pokémon live in the wild—in tall grass, trees, caves or water. If you know where to look, you can catch them using cunning and Poké Balls. The process begins when you enter one of the areas where Pokémon live and hide. Eventually, you'll flush one out and the battle will begin. If you see a Poké Ball symbol near the HP Meter of a wild Pokémon, it means that you already own one of those Pokémon.



FIELD

The most common area to find Pokémon is in tall grass. If you walk around in the grass for a while, you will eventually scare up a wild Pokémon. Each patch of grass is home to just a few sorts of Pokémon.



CAVE

Caves are home to many Pokémon, such as Zubat and Geodude. If a cave is dark when you enter, use Flash to illuminate the path. You'll encounter the subterranean inhabitants as you walk around the cave.



SEA

Once you have the Surf move and the Fog Badge from the Ecrutek City Gym, you can surf over bodies of water and find Water-type Pokémon of many varieties. Just surf back and forth until a Pokémon shows up.



FISHING

You can catch Water-type Pokémon without getting your feet wet if you use one of the fishing poles—the Old Rod, Good Rod or Super Rod. Cast your line into the water from any shore and wait for a bite.



ROCK (ROCK SMASH)

Pokémon even hide beneath some rocks. If you've earned the Rock Smash move, you can take a look under the smashable types of rocks. If a wild Pokémon is hiding there, it will attack you for disturbing its sleep.

Tree (Headbutt)

After earning the Headbutt move, you'll be able to ram trees to shake loose any Pokémon hiding there. They will be knocked to the ground where they'll attack. The chart below shows the different Pokémon that you are likely to find when you Headbutt trees in wooded or mountain areas.



Pokémon indicated in red are relatively rare.

Pokémon indicated in black are relatively common.

	GOLD	SILVER
WOOD AREA	CATERPIE	WEEDLE
	METAPOD	KAKUNA
	BUTTERFREE	BEEBRILL
	EXEGGCUTE	EXEGGCUTE
	PINECO	PINECO
MOUNTAIN AREA	HERACROSS	HERACROSS
	SPEAROW	SPEAROW
	AIPOM	AIPOM

BRING HOME THE POKÉMON

Catching Pokémon isn't as easy as it may seem. First, you must encounter a wild Pokémon, and you must have a Poké Ball to throw at it. You don't want to face the wild Pokémon with an overly powerful Pokémon from your team because your Pokémon could easily overwhelm the less powerful, wild Pokémon with one attack. You need to be patient, and you may have to use several Poké Balls to accomplish the task. Specialized Poké Balls will help you catch some of the tougher Pokémon.

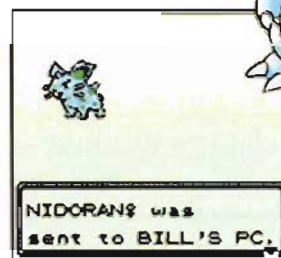

1. ATTACK

Your goal is to reduce the wild Pokémon's HP Meter as close to zero as possible without having it faint. Use your weaker attacks and attack with Pokémon that are not much more powerful than the wild Pokémon that you're fighting.

2. INCAPACITATE

Use attacks that induce sleep or paralysis in the wild Pokémon so you can whittle away at its HP Meter without taking damage. Once a wild Pokémon is asleep or frozen, you can attack with a weak Pokémon, reducing your opponent's HP by small margins until it's just about ready to faint.

3. THROW A POKÉ BALL

When you've reduced the wild Pokémon's HP Meter as close to zero as possible, it's time to try to capture it with a Poké Ball. Choose a ball from the Poké Ball pocket of your pack. It will be thrown automatically, and in a few seconds you'll see if you've captured the Pokémon or if it managed to escape the attempt.

4. STORE IN BILL'S PC

If all goes well, you'll manage to capture the new Pokémon. But if you have six Pokémon on your team already, the new addition will be sent automatically to Bill's PC for storage. You can withdraw the new Pokémon when you access Bill's PC at any Pokémon Center.

CRITICAL CONDITIONS

Incapacitating a Pokémon can make it easier to capture. Another trick is to use attacks such as Poison and Burn that slowly reduce HP. Their effects are continuous, so you'll have to throw your Poké Ball before the attack makes the Pokémon faint.



POISON



FREEZE



PARALYZE



BURN



SLEEP

HYPNOSIS, SPORE: Put those pesky wild Pokémon to sleep using attacks such as Hypnosis and Spore. If the attack is successful, the opponent won't fight back, at least for awhile. That is the time to use your weak attacks to chip away at the Pokémon's HP. The whole idea is to keep your opponent in the match, if just barely.



MEAN LOOK, SPIDER WEB: Two special attacks—Mean Look and Spider Web—keep your opponent from running away. Although most commonly used in Trainer battles, the attacks will keep certain wild Pokémon from escaping, giving you a chance to capture them and add them to your growing collection. Always use the attacks at the beginning of the battle.



Putting a Pokémon to sleep gives you a chance to reduce its HP slowly. When you see red or yellow on the HP Meter, it's time to try throwing a Poké Ball.

FALSE SWIPE: False Swipe is probably the single most useful attack that you can use if you're trying to capture wild Pokémon. If False Swipe is successful, it will reduce your opponent's HP to one with a single hit. At that point, the wild Pokémon is as susceptible to being captured as it will ever be. After using False Swipe, throw your Poké Ball and capture the Pokémon.



ALL THE POKÉ BALLS

Poké Balls are used to capture and store Pokémon. In addition to the original types of Poké Balls, a huge assortment of specialized Poké Balls shows up in Pokémon Gold and Silver versions. The Poké Ball maker in Azalea Town makes them from different kinds of Apricorns.



POKÉ BALL

The most basic Poké Ball is still great for catching most Pokémon, particularly during the early stages of the game. Buy lots of them.

GREAT BALL

If you use a Great Ball rather than a regular Poké Ball, it will be a bit easier to catch Pokémon. One costs three times as much as the Poké Ball.

ULTRA BALL

It's even easier to catch Pokémon when you use the Ultra Ball, but it will set you back six times the amount of money as a regular Poké Ball.

MASTER BALL

You can't miss when you toss out a Master Ball. You'll find Master Balls in Goldenrod City and New Bark Town. You can't buy them.

FAST BALL (White Apricorn)

Pokémon that normally escape quickly from a battle won't have the chance if you throw a Fast Ball into the battle.

LURE BALL (Blue Apricorn)

If you have a Water-type Pokémon hooked on the line, use the Lure Ball to reel them in. Give a Blue Apricorn to Kurt in Azalea Town.

LEVEL BALL (Red Apricorn)

The lower the opponent's level is compared to the level of your Pokémon, the easier it will be to catch the wild Pokémon with the Level Ball.

HEAVY BALL (Black Apricorn)

Use the heavy-duty Heavy Ball to catch big, heavy Pokémon such as Snorlax or Onix. Regular Poké Balls just don't have the capacity.

LOVE BALL (Pink Apricorn)

If the gender of your Pokémon is opposite of that of the wild Pokémon you're fighting, the Love Ball will increase your chance for success.

FRIEND BALL (Green Apricorn)

Use the Friend Ball to capture Pokémon that you really like. If a Pokémon is captured by a Friend Ball, it will become quite attached to you.

MOON BALL (Yellow Apricorn)

It will be easier to capture any Pokémon that evolves with the Moon Stone, such as Jigglypuff and Clefairy, if you use the Moon Ball.



LUCKY NUMBER

The radio station in Goldenrod City broadcasts the Lucky Number daily. If your Trainer Number for your Pokémon matches some or all of the numbers on the radio, you'll win prizes. If you match all the numbers, you'll win the special Master Ball. Return to see the Station Manager to claim your prize. The Pokémon with the matching number must be included in your current party of six Pokémon if you are to receive the prize.



OAK'S POKÉMON TALK

Professor Oak's radio show gives Trainers hints about where they can find different varieties of Pokémon. Tune in from time to time with your Pokédex radio and listen to what the professor has to say about locations where you might want to look for wild Pokémon.



POKÉDEX LOCATION FINDER

Your Pokédex is full of useful information about the Pokémon you catch, but it also contains data on Pokémon that you've met in Trainer battles. If a Trainer uses a Pokémon during a battle, even if you don't own that Pokémon you'll be able to see where it lives in the wild on your Pokédex Location Finder Map. Pokémon that you encounter in the wild

will show up in your Pokedex, as well, but your Pokédex Location Finder Map won't show you the locations of that variety of Pokémon in the wild. As for Pokémon that you've caught, you'll see all the nest locations on the Pokedex, which is useful if you want to catch another of that variety of Pokémon to trade or evolve.



TRAINERS ON THE PHONE

During your adventure, you'll meet six special Trainers who give you their phone numbers if you defeat them in battle. They'll ask if you want to share phone numbers. If you do share your number with a Trainer, he or she will call you periodically and give you hints about finding rare Pokémon, and after the call, they'll be much easier to find in the area. They'll also give you lots of information about common Pokémon, so many calls aren't very productive.



FISHERMAN: RALPH
ROUTE 32



QWILFISH

HIKER: ANTHONY
ROUTE 33



DUNSPARCE

BUG CATCHER: ARNIE
ROUTE 35



YANMA

SCHOOLBOY: CHAD
ROUTE 38



SNUBBULL

FISHERMAN: WILTON
ROUTE 44



REMORAID

HIKER: PARRY
ROUTE 45



MARILL

SOOTHING THE SAVAGE POKÉMON

The Pokédex radio has another virtue beyond getting information about Pokémon locations. The music channels can either attract or repel certain types of Pokémon. If you play the radio in a wilderness area, it may draw Pokémon out of the grass or it may drive them away from you. You'll have to experiment with the different types of music in different locations to see the effect of the music on the many varieties of Pokémon.



REPELLING POKÉMON

After you've caught a certain variety of Pokémon, you'll probably not want to battle it over and over. You can use the Repel item to keep wild Pokémon at bay for awhile. Use Repel when travelling through areas that you've visited previously, particularly if the wild Pokémon have low levels. You won't gain much experience by fighting them, and the time wasted could be spent more productively in an area with higher-level Pokémon.



Building Levels

EXPERIENCE WANTED

To develop your Pokémon, you must gain Experience Points in battle. A Pokémon's level determines the attacks and moves it can learn. It also determines if and when your Pokémon evolves. Even though you have to win battles to earn Experience Points, you don't have to win with each Pokémon to acquire those points. The following strategies will help you get the most experience for all of your Pokémon no matter which Pokémon you use.

LEAD AND LEAVE

One of the best strategies for building levels quickly is to lead with a low-level Pokémon then switch it out for a stronger Pokémon before the battle begins. If the opponent is at a much higher level than your lead Pokémon, it will give you a lot of Experience Points even though the low-level Pokémon doesn't fight. Both of your Pokémon will share the Experience Points evenly.



In the example shown, the Level-27 Jynx leads off and earns lots of experience even though the battle is won by its more powerful teammate, Ampharos.



EXPERIENCE SHARE

The Experience Share Item presents an even better way to build levels quickly. A Pokémon that holds Experience Share will gain a higher percentage of the experience than its teammates that don't have the item. The chart demonstrates how that works in a battle where 60 Experience Points are won. Normally, teammates share experience evenly. But a Pokémon with Experience Share can earn 50% of the points even if it never enters the battle.



BATTLE EXAMPLE 1: EXPERIENCE SHARE NOT USED



- Points are divided evenly among fighting Pokémon ($60 \div 3 = 20$).
- Non-fighting Pokémon get zero.

BATTLE EXAMPLE 2:

EXPERIENCE SHARE USED (NON-FIGHTING)



- A non-fighting Pokémon with Experience Share gets half the points ($60 \div 2 = 30$).
- The remainder of the points are divided evenly among the fighting Pokémon ($30 \div 3 = 10$).
- Non-fighting Pokémon without Experience Share get zero.

BATTLE EXAMPLE 3:

EXPERIENCE SHARE USED (FIGHTING)



- A fighting Pokémon with Experience Share gets half of the points (30) plus one third of the remaining points (10) for a total of 40 points.
- The remaining points are divided evenly between the two other fighting Pokémon ($20 \div 2 = 10$).
- Non-fighting Pokémon get zero.

STOP THE EVOLUTION!

When a Pokémon reaches a particular level, it may begin to evolve. If you don't want it to evolve into the next form, push and hold the B Button until a message appears saying that the Pokémon has stopped evolving.



POWER TO THE POKÉMON

Trainers can use many items to strengthen their Pokémon in many ways. Some items will help Pokémon evolve faster while others may develop the Pokémon in one category such as Speed or Attack. For a full list of items and their effects, turn to page 110 and the Item List found there. In addition to a list of effects, you'll see where you can pick up the powerful items.



Fraternal Twins

Look carefully at the category ratings for the two Hoothoot. Notice the differences in the ratings for Defense, Special Attack, Special Defense and Speed. Even though each Hoothoot is at Level 13, it has unique strengths. The differences may reflect the use of special items. In this case, the Trainer gave one Hoothoot an Iron to increase its Defense by one point. Pokémon stats vary from creature to creature, however—even among Pokémon of the same type and level.

No. 163 13 ♂	
HOOTHOOT /HOOTHOOT	
HP: 40	
ATTACK	10
DEFENSE	10
SPCL. ATK	15
SPCL. DEF	20
SPEED	20

No. 163 13 ♀	
HOOTHOOT /HOOTHOOT	
HP: 40	
ATTACK	10
DEFENSE	11
SPCL. ATK	15
SPCL. DEF	20
SPEED	18

LEVEL UP EVOLUTION : SPECIAL

Tyrogue, a pre-evolved form of Hitmonlee and Hitmonchan, will evolve into either of those two forms, or Hitmontop, depending on its stats when it reaches Level 20. If Tyrogue's attack rating is higher, Tyrogue will evolve into Hitmonlee at Level 20. If its defense is higher, it will evolve into Hitmonchan, and its attack and defense ratings are equal, it will evolve into Hitmontop. Use Iron or Protein to choose your evolution.

Red, Blue and Yellow Versions

For veteran Trainers, the evolutionary tree of Tyrogue will seem quite odd. In the original versions of the game, Hitmonlee and Hitmonchan were acquired at the special Karate Gym in Saffron City. Players were given a choice between the two



Fighting-type Pokémon if they defeated the Karate Master and his fellow Trainers. Hitmonlee used its feet while Hitmonchan used only its hands when fighting a Pokémon battle.



TYROGUE

LEVEL 20
 ATTACK/DEFENSE ▲

LEVEL 20
 ATTACK/DEFENSE ► HITMONTOP

LEVEL 20
 ATTACK/DEFENSE ▼

HITMONCHAN



Trade Transformations

TRAVEL BROADENS THE POKÉMON

Certain Pokémon will evolve into their higher forms when they are traded to another Gold or Silver Game Pak. If you have a Kadabra, Machoke, Graveler or Haunter, you can transfer it to someone else then receive an evolved Pokémon in return. Trust is a beautiful thing.



KADABRA

ALAKAZAM

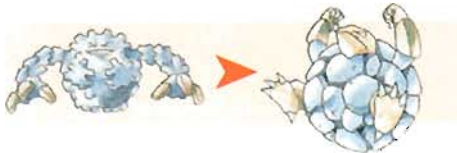

GRAVELER

GOLEM



HAUNTER

GENGAR

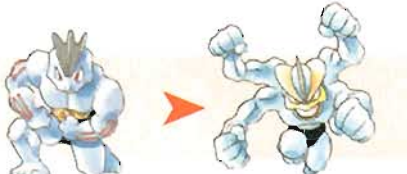

MACHOKE

MACHOP

EVOLUTIONARY BAGGAGE

Some Pokémon come into being through a natural evolutionary process; others require a special item. Once you find the special items shown below, have the indicated Pokémon hold them when you trade them to another Gold or Silver Game Pak. The transfer will produce new evolutionary forms.



POLIWHIRL

KING'S ROCK



POLITOEED



SLOWPOKE

KING'S ROCK



SLOWKING



ONIX

METAL COAT



STEELIX



SCYTHER

METAL COAT



SCIZOR



SEADRA

DRAGON SCALE



KINGDRA

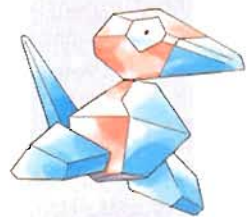

PORYGON

UP-GRADE



PORYGON2

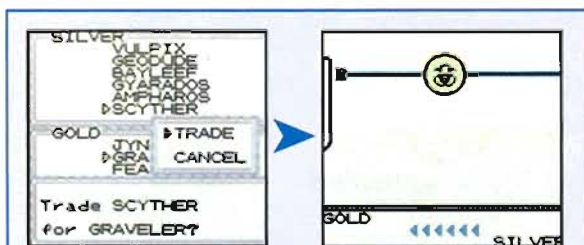

TROUBLING TRANSFERS

Remember: You can transfer only Pokémon that appeared previously in Red, Blue and Yellow from Gold and Silver to Red, Blue and Yellow. New Pokémon or those with new items or abilities cannot be traded from Gold and Silver to Red, Blue, and Yellow. That group includes old Pokémon that have evolved into new Pokémon.

Stepping Stones of Evolution

MINERAL SUPPLEMENTS

As you may already know from previous versions of the game, you can use special stones to induce evolution in specific Pokémon. You won't need to conduct a trade to make them evolve—just have the indicated Pokémon use the stones to alter their evolutionary development. Gloom and Eevee can transform into more than one form, depending on the stone they use to evolve.

SUN STONE

There's something new under the sun in the world of stone evolution. Gold and Silver introduce the Sun Stone, which you can use to transform Sunkern into Sunflora and Gloom into Bellossom—no greenhouse necessary.

WATER STONE



POLIWHIRL POLIWRATH

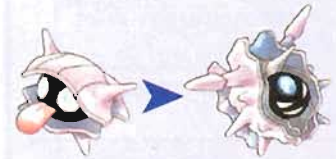

SHELLDER CLOYSTER



STARYU STARMIE

FIRE STONE



VULPIX NINETALES



GROWLITHE ARCANINE

THUNDER STONE



PIKACHU RAICHU

LEAF STONE



WEEPINBELL VICTREEBEL



EXEGGCUTE EXEGGUTOR

MOON STONE



NIDORINA NIDOQUEEN



CLEFAIRY CLEFABLE



NIDORINO NIDOKING



JIGGLYPUFF WIGGLYTUFF

SUN STONE



SUNKERN



SUNFLORA

USING DIFFERENT STONES

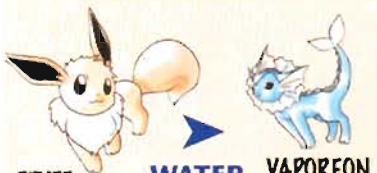

EEVEE WATER STONE VAPOREON



EEVEE THUNDER STONE JOLTEON



EEVEE FIRE STONE FLAREON



GLOOM LEAF STONE VILEPLUME



GLOOM

SUN STONE



BELLOSSOM

Friendly Evolution

YOU'RE MY BEST FRIEND!

Some Pokémon need more than just experience to evolve—they need to be attached to you, too. If you treat those Pokémon very well, they will evolve on schedule when they reach the proper level. But if the Pokémon are not attached to you, they will not evolve. While many Pokémon will evolve regardless of how well you treat them, you should try to be a good Trainer to all of your Pokémon. Many events in the game are based on how attached your lead Pokémon is to you.

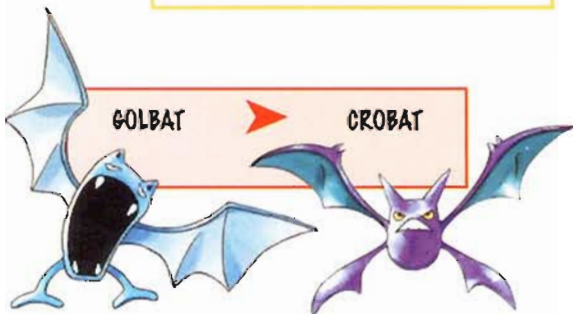
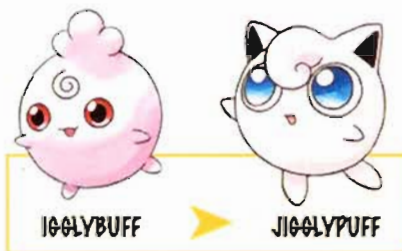
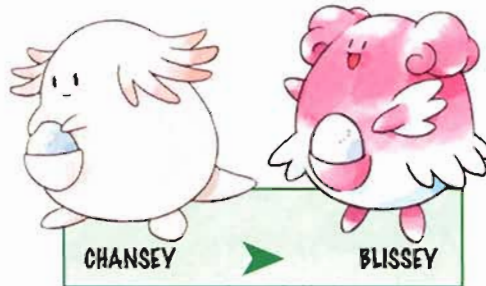
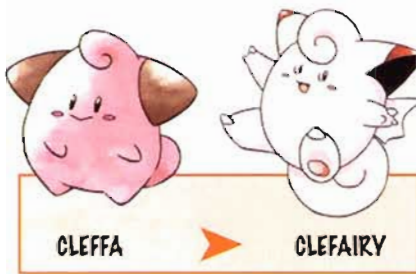
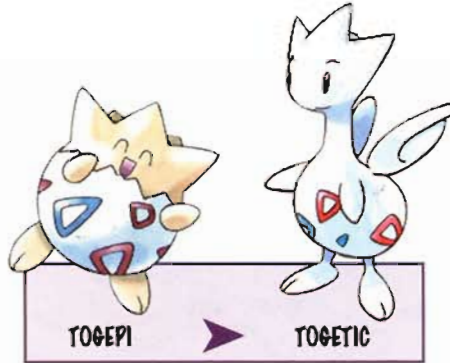
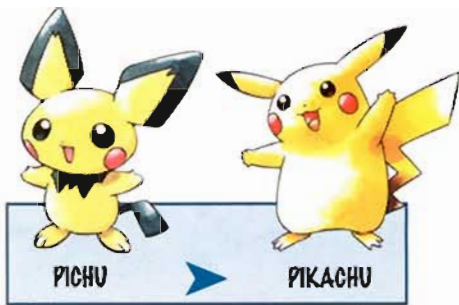

DAY OR NIGHT

Eevee's other evolutions are created with Stones, but Espeon and Umbreon are not. Eevee evolves into either Espeon or Umbreon when it's extremely attached to you, and its evolution starts at a certain time of day. To get Espeon, allow Eevee to evolve in the morning or day. For Umbreon, allow Eevee to evolve at night.

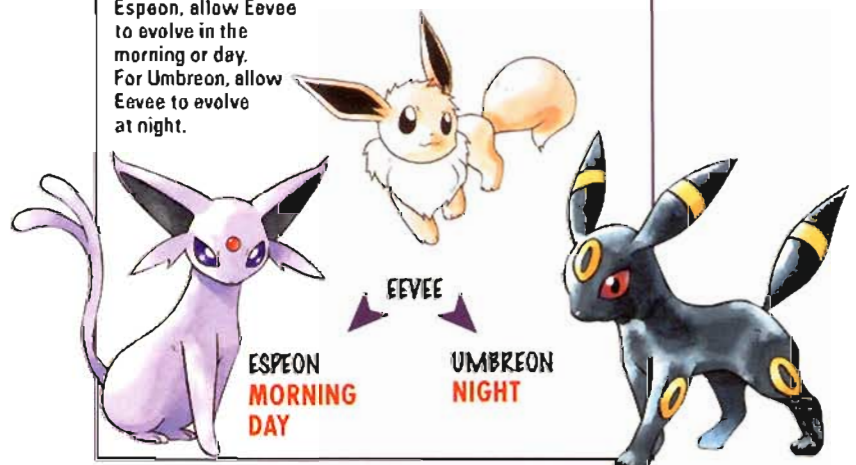

DO'S AND DON'TS

There are quite a few things that will help your relationship with your Pokémon, and a couple that will hurt your relationship with your Pokémon. You should try to forge strong relationships with all of your Pokémon, but especially the party you travel with most often.



DO:

Have your Pokémon groomed in Pallet Town by Blue's Sister.

Get your Pokémon's hair cut by one of the Haircut Brothers.

Travel with a Pokémon and keep it in your party as often as possible.

Use many items on a Pokémon and let it hold an item, too.

DON'T:

Let your Pokémon faint in battle or repeatedly allow it to get very weak.

Make the Pokémon take bitter medicine, or trade it away to another Trainer.

In-Game Events

FOUR WAYS TO ACQUIRE POKÉMON

Aside from catching wild Pokémon that attack you, there are four other ways to get your hands on Pokémon. Some of the rarest Pokémon are creatures you can't catch in the wild, so study this list for information on how to get them.

THE GIFT POKÉMON



CHIKORITA



CYNDAQUIL



TOTODILE

NEW BARK TOWN

Professor Elm will give you a Pokémon for helping him with an errand. You get to choose whether it's Chikorita, Cyndaquil or Totodile, and you won't get the other two from Elm.



SHUCKLE

CIANWOOD CITY

The Shuckle you keep safe is yours if it becomes attached to you.



EEVEE

GOLDENROD CITY

After you meet up with Bill, return to his house where you will get an Eevee.



TYROGUE

MT. MORTAR

If you defeat Blackbelt Kyo in Mt. Mortar, he will give you Tyrogue.

GAME PRIZES

GOLDENROD CITY



ABRA
200



EKANS
GOLD
700

CELADON CITY



MR. MIME
3,333



EEVEE
6,666



SANDSHREW
SILVER
700



PRATINI
2,100



PORYGON
9,999

(Prices refer to the number of coins)

NATIONAL PARK: BUG-CATCHING EVENT



CATERPIE



METAPOD



BUTTERFREE



WEEDLE



KAKUNA



BEEBRILL



VENONAT



PARAS



SCYTHYR



PINSIR

IN-GAME TRADES

VIOLET CITY



BELLSPROUT



ONIX

GOLDENROD CITY



PROWZEE



MACHOP

OLIVINE CITY



KRABBY



VOLTORB

BLACKTHORN CITY



DRAGONAIR ♀



RHYDON

PEWTER CITY



GLOOM



RAPIDASH

ROUTE 14



CHANSEY



AERODACTYL

Pokémon Eggs

Pokémon Gold and Silver allow you to raise your own Pokémon at the Breeding Center just south of Goldenrod City on Route 33. With a little patience, you can raise many Pokémon.



POKÉMON DAYCARE

The man and woman who run the Daycare can take one Pokémon each to raise for you. An unexpected bonus sometimes happens when you board two Pokémon of opposite genders, or any Pokémon with a Ditto. If the Pokémon like each other, you may return to the Daycare a while later to find that a Pokémon Egg has appeared. No one is quite sure how it happens, but when it does, you simply have to carry the Egg in your party for a while to hatch it into a Pokémon—maybe even a new pre-evolution will appear!



CHECK THEIR FRIENDSHIP

Your Pokémon may or may not like each other. Walk outside into the Pokémon Daycare's yard and use the A Button to check on your Pokémon and see what their interest level is. If both Pokémon show an interest in each other, you will end up with a Pokémon Egg eventually. If they show no interest in each other, there will not be an Egg for you to hatch.

CHECK THE MESSAGE

The message you get will let you know if a Pokémon Egg is on the way.



- It appears to care for other Pokémon
- It shows interest in the other Pokémon
- It's friendly with the other Pokémon



- It's brimming with energy
- It has no interest in the other Pokémon

Same Pokémon



Different Pokémon

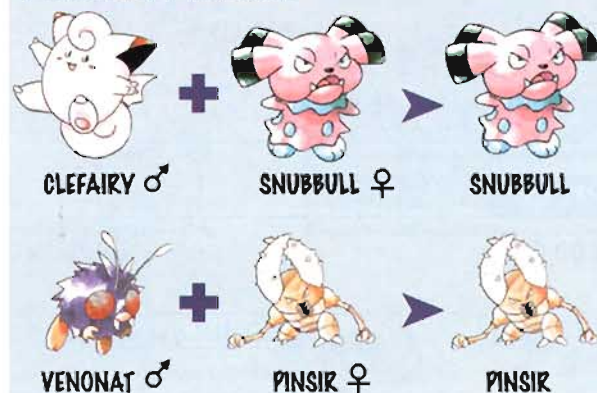

NO EGGS

Some Pokémon will never produce Eggs for you to hatch. They're shown in the "No Eggs" on page 95. Some are the pre-evolution Pokémon, while others are Legendary Pokémon that are one-of-a-kind in each Game Pak. Whatever the case, you won't find Eggs from those Pokémon.



Male or Female

Some Pokémon have only one gender. Kangaskhan, for example, are always female, while Tauros are always male. Leave those Pokémon with Pokémon of the opposite gender. If they like each other, you will get an Egg containing a Pokémon like the female of the pair.

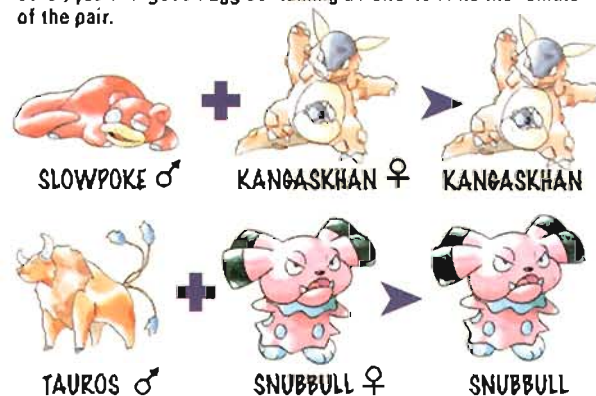

No Eggs

You won't be able to produce Eggs with some Pokémon. You can still leave them with the Pokémon Daycare if you want to raise their levels easily, however.



UNOWN



Female Pokémon

Some Pokémon are always female.



NIDORAN ♀



Male Pokémon

Some Pokémon are always male.



Neuter

Some Pokémon do not have a gender, but you can still hatch their Eggs with Ditto's help.



DITTO

Ditto has no gender, so it may produce Eggs with either male or female Pokémon. Pokémon will usually show interest in Ditto. The Egg produced will always hatch the lowest evolution of a particular Pokémon. For example, if you leave a Magneton and a Ditto at the Daycare, the resulting Egg will hatch into a Magnemite, not a Magneton. Pokémon that are exclusively male will produce a younger version of themselves with Ditto only. You must have two Ditto to produce a Ditto Egg.

Hatching After you pick up the Pokémon Egg from the Pokémon Daycare, you must carry it around in your party with active, healthy Pokémon, or it won't hatch. Some Pokémon take longer than others to produce an Egg, and some Eggs take longer than others to hatch.

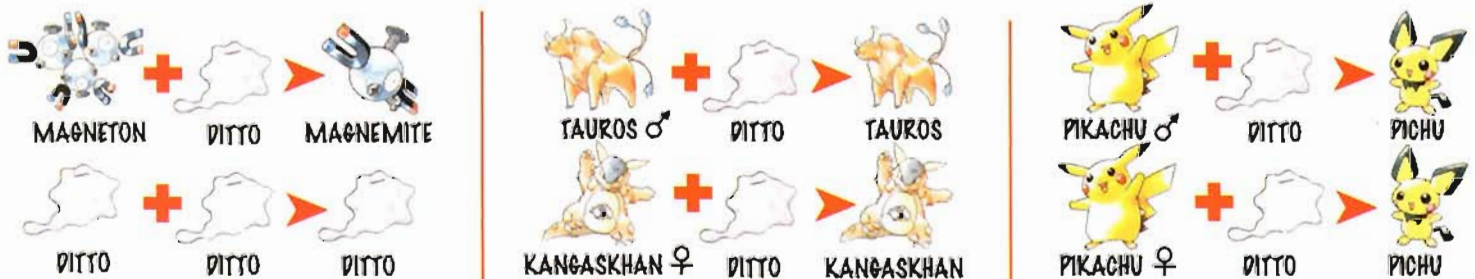

Pokémon Relocation



TRADE POKÉMON WITH THE GAME LINK CABLE

Each version of the game has Pokémon you can't find in other versions, so you'll need to trade with other Trainers to complete your Pokédex. As you collect Pokémon in your travels, be sure to set aside those that you know are unique to your version. When you meet a Trainer with a different version, connect your Game Boy systems with a Game Link Cable to swap your most coveted creatures.

UNAVAILABLE IN GOLD VERSION

TRANSFER FROM **RED, BLUE, YELLOW, SILVER**



VULPIX

NINETALES

MEOWTH

PERSIAN

TRANSFER FROM **SILVER**



PHANPY

DONPHAN

SKARMORY

LEDYBA

LEDIAN

DELIBIRD

UNAVAILABLE IN SILVER VERSION

TRANSFER FROM **RED, BLUE, YELLOW, GOLD**



MANKEY

PRIMEAPE

GROWLITHE

ARCANINE

TRANSFER FROM **GOLD**



TEDDIURSA

URSARING

GLIGAR

SPINARAK

ARIADOS

MANTINE

UNAVAILABLE IN GOLD & SILVER VERSIONS

TRANSFER FROM **RED, BLUE, YELLOW**



BULBASAUR

IVYSAUR

VENUSAUR

SQUIRTLE

WARTORTLE

BLASTOISE

KABUTO

KABUTOPS

CHARMANDER

CHARMELEON

CHARIZARD

ARTICUNO

ZAPPOS

MOLTRES

OMANYTE

OMASTAR

MEWTWO

Many of the most famous and prized Pokémon from earlier games cannot be found in the wild in Gold and Silver. You can transfer them from previous versions, but you can't trade new Pokémon in return.

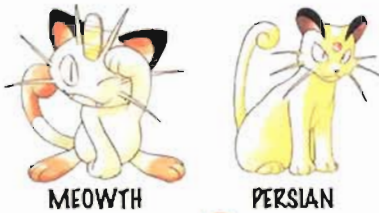
UNAVAILABLE IN YELLOW VERSION (#1-150)
TRANSFER FROM BLUE, SILVER

MEOWTH

PERSIAN



MAGMAR

TRANSFER FROM RED, GOLD, SILVER

EKANS

ARBOK



ELECTABUZZ

TRANSFER FROM RED, BLUE, GOLD, SILVER

WEEPLE

KAKUNA

BEEBRILL



KOFFING

WEEZING

JYNX

UNAVAILABLE IN RED VERSION (#1-150)
TRANSFER FROM BLUE, YELLOW, SILVER

VULPIX

NINETALES



MEOWTH



PERSIAN

TRANSFER FROM BLUE, YELLOW, GOLD, SILVER

SANDSHREW

SANDSLASH

MAGMAR



BELLSPOUT



WEEPINBELL



VICTREEBEL



PINSIR

UNAVAILABLE IN BLUE VERSION (#1-150)
TRANSFER FROM RED, YELLOW, GOLD

MANKEY

PRIMEAPE



GROWLITHE



ARCANINE

TRANSFER FROM RED, YELLOW, GOLD, SILVER

ODDISH

EKANS

ARBOK

SCYTHYR



GLOOM



VILEPLUME



ELECTABUZZ

Rare Pokémon

Some Pokémon are so special, you won't have many chances to catch them. Some of the Pokémon can be raised at the Pokémon Daycare, but others appear only once in the game, and if you blow it, they're gone forever. Be careful when trying to catch the rarest of Pokémon, and remember to save often!



CHIKORITA

TOTODILE

Remember that when you choose one starting Pokémon, you're also choosing not to have the other two. They do not appear in the wild, so you'll have to trade to get the other two. Maybe your friends could hatch something up for you...



CYNDQUIL



HO-OH

The Legendary Birds are one-per-Pak, so you should buy a ton of Poké Balls, power up, then save your game right before trying to catch Ho-oh. The second Legendary bird you catch will be much harder to capture than the first one was, so be prepared to try over and over again—or use the Master Ball.



LUGIA

Like Ho-oh, Lugia is very rare. Unlike many of the other creatures listed here, the Legendary Birds are genderless, and you cannot raise more by taking them to the Pokémon Daycare. Be very careful when trying to capture Lugia, and save right before you make an attempt.



EEVEE

The Eevee that you pick up at Bill's house is one of the few you'll find in the game. You can win an Eevee at Celadon City's Game Corner, and you can raise a few extra Eevee at the Pokémon Daycare to have all of its evolutions.

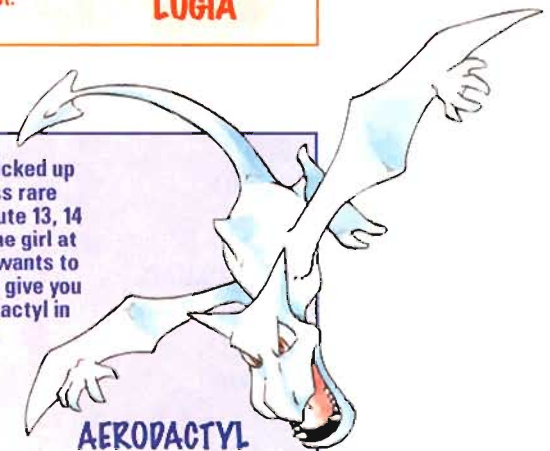

AERODACTYL

After you've picked up the slightly less rare Chansey at Route 13, 14 or 15, talk to the girl at Route 14 who wants to trade. She will give you the only Aerodactyl in the game for a Chansey.



ENTEI

The three fantastically bizarre creatures, Raikou, Entei and Suicune, are extremely rare, and there is no one place to catch them. After you scare them away from the Burned Tower, they will randomly appear in the tall grass of Johto. After you encounter them in the wild, they will appear in your Pokédex, and you can check to see where they are at any time. They move very fast, however, so you might not reach them in time. Use Max Repel or Super Repel in grassy areas to keep away all Pokémon except one of the three. Try to use one of Kurt's Fast Balls to catch the Pokémon—they will run away very quickly, giving you little time to wear them down before throwing the Poké Ball. They will not heal the damage they take, so you can wear them down over many sightings until you can catch them.



RAIKOU



SUICUNE



TOGEPI

You won't find Togepi out in the wild, but you also don't have to worry about catching the only Togepi in the game—Professor Elm's assistant will give you a Pokémon Egg, and when it hatches, Togepi is all yours.

It's a very good idea to find Blackbelt Kyo and defeat him, because he will present you with the extremely rare Tyrogue as a tribute to your victory. You could probably hatch a Tyrogue, too, if you had a Hitmonlee or Hitmonchan...

TYROGUE

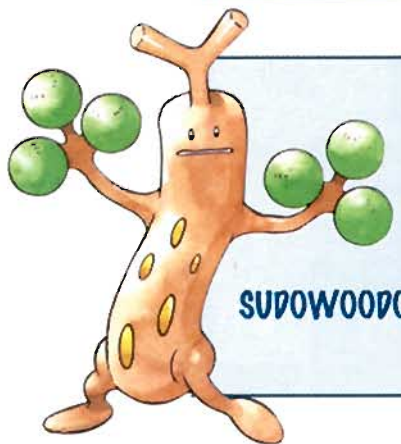

SUDOWOODO

The odd living tree that you use the Squirrbottle on is Sudowoodo, and that incident is the only occasion where you'll encounter the Rock-type Pokémon. Save before you use the Squirrbottle, or you might miss your one chance to own the incredible fake.

As with Pokémon Red, Blue and Yellow, Porygon is found in one place only—the Celadon City Game Corner. You have to be lucky or rich to get one—it will cost you 9,999 coins.

PORYGON

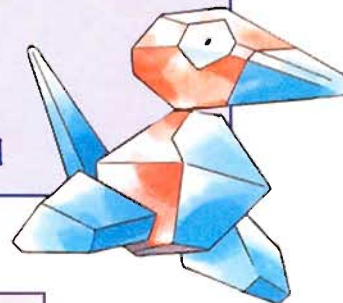

SNORLAX

Try to save right before you wake up the sleeping Snorlax with the Pokéflute. If you accidentally knock Snorlax out, you can restart your game and try again. The powerful Normal-type creature is at Level 50 when you encounter it and would make a great addition to any team.

Johto Weekly Event Map

Many of the events that take place in Johto occur on specific days of the week. This map provides a simple reference to each of those events, indicating where the event takes place and on which day it takes place.

THE DAY SIBLINGS

The Day Siblings are an odd family that really gets around. There are seven children in the family, and each has a post to occupy once a week. If you meet up with one of the Day Siblings, you will get a special item that will help you on your journey.

- MONICA/SHARP BEAK** Route 40: Monday
- TUSCANY/PINK BOW** Route 29: Tuesday
- WESLEY/BLACK BELT** Lake of Rage: Wednesday
- ARTHUR/HARD STONE** Route 36: Thursday
- FRIEDA/POISON BARR** Route 32: Friday
- SANTOS/SPELL TAG** Blackthorn City: Saturday
- SUNNY/MAGNET** Route 37: Sunday

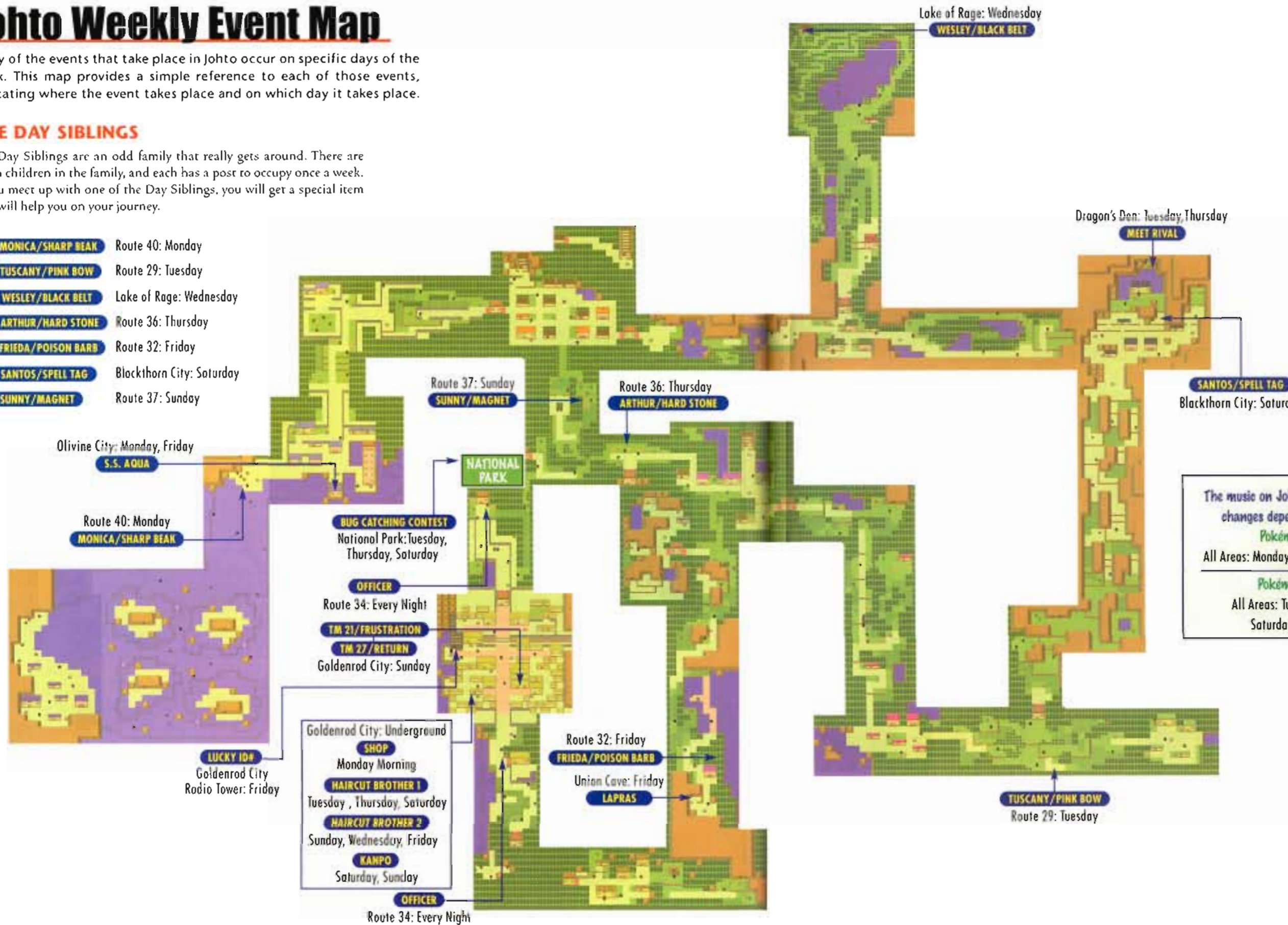

The music on Johto radio channel 7.5 changes depending on the day.

Pokémon Lullaby
All Areas: Monday, Wednesday and Friday

Pokémon March
All Areas: Tuesday, Thursday, Saturday and Sunday

Goldenrod City: Underground **SHOP**
Monday Morning

HAIRCUT BROTHER 1
Tuesday, Thursday, Saturday

HAIRCUT BROTHER 2
Sunday, Wednesday, Friday

KANPO
Saturday, Sunday

Johto Phone Call Map

Your phone will be ringing off the hook once you start defeating other Trainers. Sometimes they will want a rematch. Other times they just want to talk. The map shows the location of the Trainers when you first meet them. Return to the same spots for rematches.

I JUST CALLED TO SAY...LET'S FIGHT!

The phone calls will begin in earnest after you've registered an opposing Trainer's name on your phone list. Trainers will ask you for your phone number after you defeat them. If you say yes, their number will be registered in your Pokégear. The calls occur at random.



Johto Tree Map

In addition to improving the scenery, some of the trees in Johto provide special items that are uniquely helpful to Pokémon Trainers. The fruit-bearing trees look different from the varieties that merely block your progress. Reap their bounty, and save yourself a trip to the Pokémon Mart.

BERRY, BERRY GOOD

The most plentiful fruit available in Johto are different types of curative Berries. Simple Berries will restore HP to your Pokémon, much like the Potion you can buy at the Pokémon Mart. Other Berries treat debilitating conditions like burns and paralysis.



APRICORN CRAFTS

Unlike the different Berries, Apricorns have no medicinal value, but they are extremely valuable. After you've met the Poké Ball master craftsman, Kurt, you can bring him different types of Apricorns that he'll transform into special Poké Balls.

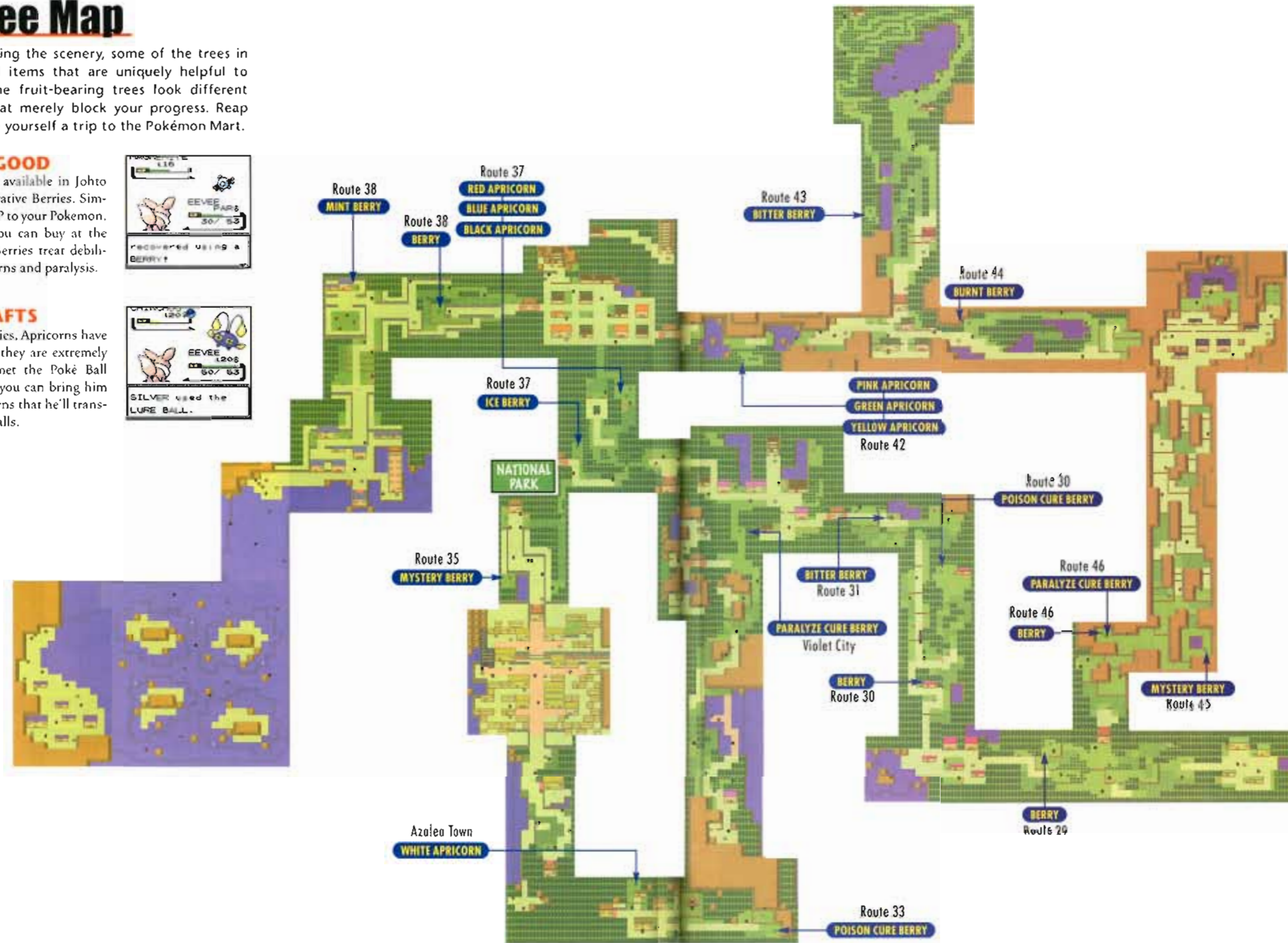

Kanto Weekly Event, Phone Call and Tree Map

With all the phone calls and scheduled events in Kanto, your appointment calendar will fill up quickly. Should you meet your rival for a battle at Indigo Plateau on Wednesday, or head over to the S.S. Aqua instead? You can do both, but not on any other day of the week. If you're having trouble keeping your schedule straight, consult the handy map below for critical times and locations.

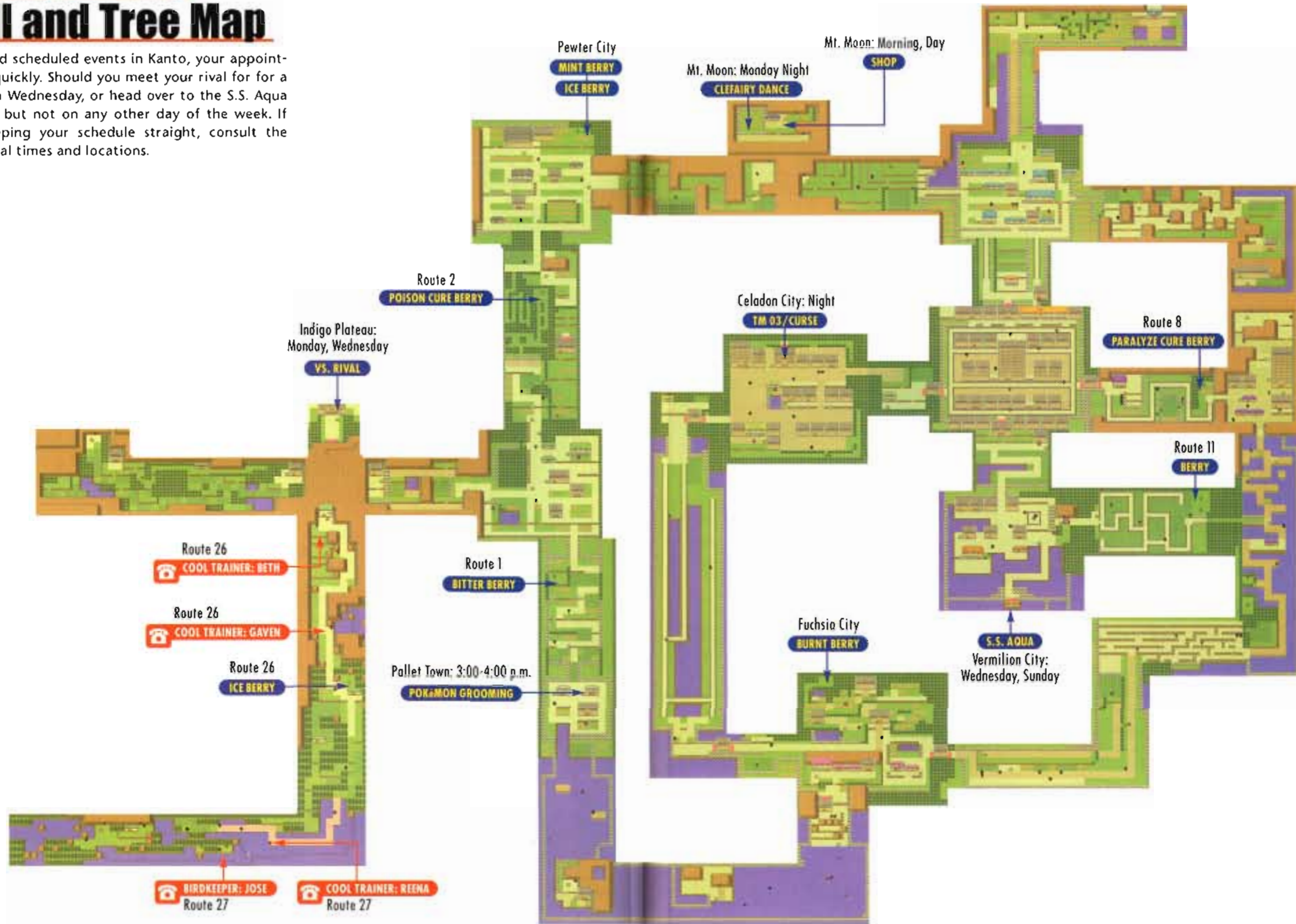

ITEM LIST

HEALTH ITEMS

ITEM	DESCRIPTION	LOCATION	PRICE
Antidote	Cures poisoned Pokémon	Pokémon Mart/Route 31	100
Awakening	Wakes sleeping Pokémon	Pokémon Mart/Caves	250
Berry Juice	Restores 20 HP	Give a Berry to Shuckle	-
Burn Heal	Heals burned Pokémon	Pokémon Mart/Towns/Caves	250
Elixir	Restores 10 PP to all abilities	Roads /Caves/Gift	-
Energy Root	Restores 200 HP but is very bitter	Goldenrod City	800
Energy Powder	Restores 50 HP but is very bitter	Goldenrod City	500
Ether	Restores 10 PP to one ability	Roads/Caves/Gift	-
Fresh Water	Restores 50 HP	Department Store/Mt. Moon	200
Full Heal	Cures any condition	Pokémon Mart/Caves	600
Full Restore	Cures any condition, restores all HP	Indigo Plateau/Caves	3,000
Heal Powder	Cures any condition but is very bitter	Goldenrod City	450
Hyper Potion	Restores 200 HP	Pokémon Mart/Roads/Caves	1,200
Ice Heal	Thaws frozen Pokémon	Pokémon Mart	250
Lemonade	Restores 80 HP	Department Store/Mt. Moon	350
Max Elixir	Restores all PP to all abilities	Roads/Caves/Gift	-
Max Ether	Restores all PP to one ability	Goldenrod City/Roads/Gift	-
Max Potion	Restores all HP	Pokémon Mart/Roads/Caves	2,500
Max Revive	Revives fainted Pokémon, restores all	Roads/Caves	-
MooMoo Milk	Restores 100 HP	MooMoo Farm/Wild Pokémon	500
Paralyze Heal	Cures paralyzed Pokémon	Pokémon Mart/Caves	200
Potion	Restores 20 HP	Pokémon Mart/Roads/Caves	300
Rage Candy Bar	Restores 20 HP	Mahogany Town	200
Revival Herb	Revives fainted Pokémon	Goldenrod City	2,800
Revive	Revives fainted Pokémon, restores 1/2 HP	Pokémon Mart/Roads/Caves	1,500
Sacred Ash	Revives all fainted Pokémon	Wild Pokémon	-
Soda Pop	Restores 60 HP	Department Store/Mt. Moon	300
Super Potion	Restores 50 HP	Pokémon Mart/Roads/Caves	700

BERRIES

ITEM	DESCRIPTION	LOCATION
Berry	Restores 10 HP	National Park/Routes 29, 30, 38, 46, 11/Gift/Trade
Bitter Berry	Cures confused Pokémon	Blackthorn City/Routes 31, 43, 1/Gift
Burnt Berry	Thaws frozen Pokémon	Route 44/Fuchisa City/Pewter City/Gift/Trade
Gold Berry	Restores 30 HP	National Park/Gift/Trade
Ice Berry	Heals burned Pokémon	Pewter City/Routes 36, 26/Gift/Trade
Mint Berry	Wakes sleeping Pokémon	Routes 39/Pewter City/Gift
Miracle Berry	Heals all conditions	Gift
Mystery Berry	Restores PP	Routes 35, 45/Trade
Paralyzecure Berry	Cures paralyzed Pokémon	Violet City/Routes 46, 8/Gift
Poisoncure Berry	Cures poisoned Pokémon	Routes 2, 30, 33/Gift

ITEM LIST

KEY ITEMS

ITEM	DESCRIPTION	LOCATION
Basement Key	Opens door to Underground Path	Goldenrod City
Bicycle	Move twice as fast	Goldenrod City
Card Key	Opens Radio Tower shutter	Goldenrod City
Coin Case	Carry up to 9,999 coins	Goldenrod City
Good Rod	Improved fishing rod	Olivine City
Item finder	Reacts to items lying around with a sound	Ecruteak City
Clefairy Doll	Exchange for Pass at Saffron City	Vermilion City
Machine Part	Give to Power Plant Manager	Cerulean City
Mystery Egg	Togepi is born	Route 30
Old Rod	Item for fishing for Pokémon	Route 32
Pass	Ride on the Magnet Train	Saffron City
Rainbow Wing	Allows Trainers to climb Tin Tower	Goldenrod City (Gold)/Pewter City (Silver)
Red Scale	Exchange for Experience Share on Route 30	Lake of Rage
S.S. Ticket	Ride the boat S.S. Aqua	New Bark Town
Secret Potion	Heals Amphy in the Lighthouse	Cianwood City
Silver Wing	Lugia appears at Whirl Island	Goldenrod City (Silver)/Pewter City (Gold)
Squirtbottle	Move the Sudowoodo on Route 36	Goldenrod City
Super Rod	Best fishing rod	Route 12

HELPFUL ITEMS

ITEM	DESCRIPTION	LOCATION	PRICE
Escape Rope	Provides a quick escape from towers and caves	Pokémon Mart/Caves	550
Expn Card	Allows you to listen to the radio in Kanto	Lavender Town	
Map Card	The Pokégear's Map	Cherrygrove City	
Max Repel	Repels weak Pokémon for 250 steps	Pokémon Mart/Gift	700
Poké Doll	Provides escape from wild Pokémon	Department Store/Mt. Moon	1,000
Pokédex	Stores Pokémon data	Route 30	
Radio Card	Lets you listen to the radio with the PokéGear	Goldenrod City	
Repel	Repels weak Pokémon for 100 steps	Pokémon Mart/Mt. Moon	350
Super Repel	Repels weak Pokémon for 200 steps	Pokémon Mart/Gift	500
Unown Dex	Pokédex shows the Unown you caught in order	Ruins of Alph	-

APRICORNS

ITEM	DESCRIPTION	LOCATION
Black Apricorn	Raw material for Heavy Ball	Route 37
Blue Apricorn	Raw material for Lure Ball	Route 37
Green Apricorn	Raw material for Friend Ball	Route 42
Pink Apricorn	Raw material for Love Ball	Route 42
Red Apricorn	Raw material for Level Ball	Route 37
White Apricorn	Raw material for Fast Ball	Azalea Town
Yellow Apricorn	Raw material for Moon Ball	Route 42

ITEM LIST

ABILITY UP

ITEM	DESCRIPTION	LOCATION	PRICE
Amulet Coin	Doubles the money won in battle	Goldenrod City	
Berserk Gene	Increases attack by 2 levels, confuses	Cerulean City	
Black Belt	Increases power of Fighting-type attacks	Lake of Rage	
Black Glasses	Increases power of Dark-type attacks	Dark Cave	
Bright Powder	Lowers opponent's accuracy	Trade/Wild	
Calcium	Raises Special Attack/Defense	Department Store/Roads/Caves	9,800
Carbos	Raises speed	Department Store/Roads/Caves	9,800
Charcoal	Increases power of Fire-type attacks	Azalea Town	9,800
Cleanse Tag	Makes it difficult to run into wild Pokémon	Route 5	
Dire Hit	Good chance of a Critical Hit (one battle)	Pokémon Mart/Roads/Caves	650
Dragon Fang	Increases power of Dragon-type attacks	Dragon's Den	
Dragon Scale	Evolves Pokémon	Mt. Mortar/Trade/Wild	
Everstone	Prevents a Pokémon from evolving	New Bark Town/Roads/Trade/Wild	
Exp. Share	One Pokemon receives half of all Exp. points	Goldenrod City/ Route 30	
Fire Stone	Evolves Pokémon	Gift	
Focus Band	Prevents a Pokémon from fainting	Saffron City	
Guard Spec.	Guards against Special Attacks (one battle)	Department Store/Caves/Gift	700
Hard Stone	Increases power of Rock-type attacks	Route 36	
HP Up	Raises HP	Dept. Store/ Mart/Roads/Caves/Gift	9,800
Iron	Raises defensive power points	Department Store/Caves	9,800
King's Rock	Makes opponent retreat/evolves Pokémon	Slowpoke Well/Trade/Wild	
Leaf Stone	Evolves Pokémon	Gift	
Leftovers	Gradually restores points during battle	Celadon City/Trade/Wild	
Light Ball	Doubles Pikachu's special attacks	Trade/Wild	
Lucky Egg	Grants more exp. points after a battle	Trade/Wild	
Lucky Punch	Good chance of a Critical Hit	Trade/Wild	
Magnet	Increases power of Electric-type attacks	Route 37	
Metal Coat	Increases power of Steel-type attacks	S.S. Aqua/Trade/Wild	
Metal Powder	Increases Ditto's defensive power	Trade/Wild	
Miracle Seed	Increases power of Grass-type attacks	Route 32	
Moon Stone	Evolves Pokémon	Mom/ Route 27/Trade/Wild	
Mystic Water	Increases power of Water-type attacks	Cherrygrove City	
Nevermelt Ice	Increases power of Ice-type attacks	Ice Path	
Pink Bow	Increases power of Normal-type attacks	Route 29/Goldenrod City	
Poison Barb	Increases power of Poison-type attacks	Route 32/Trade/Wild	
Polkadot Bow	Increases power of Normal-type attacks	Trade/Wild	
PP Up	Raises PP	Town/Roads/Caves/Gift	
Protein	Raises attack points	Department Store/Roads/Caves	9,800
Quick Claw	Good chance of attacking first	National Park/Trade/Wild	
Rare Candy	Raises Pokémon's level by one	Town/Roads/Caves	
Scope Lens	Good chance of a Critical Hit	Gift	
Sharp Beak	Increases power of Flying-type attacks	Route 40/Trade/Wild	

ITEM	DESCRIPTION	LOCATION	PRICE
Silver Powder	Increases power of Bug-type attacks	Trade/Wild	
Smoke Ball	Provides escape from wild Pokémon	Goldenrod City	
Soft Sand	Increases power of Ground-type attacks	Route 34	
Spell Tag	Increases power of Ghost-type attacks	Blackthorn City/Trade/Wild	
Stick	Increases power of Farfetch'd's attacks	Trade/Wild	
Sun Stone	Evolves Pokémon	National Park	
Thick Club	Increases Cubone/Marowak phys. attack	Trade/Wild	
Thunder Stone	Evolves Pokémon	Gift	
Twisted Spoon	Increases power of Psychic-type attacks	Trade/Wild	
Up-Grade	Evolves a specific Pokémon	Saffron City	
Water Stone	Evolves Pokémon	Gift	
X Accuracy	Increases accuracy (one battle)	Department Store/Town/Caves	950
X Attack	Increases attack power (one battle)	Pokémon Mart/Caves/Gift	500
X Defend	Increases defense (one battle)	Pokémon Mart/Caves/Gift	550
X Special	Raises Special Attack power (one battle)	Pokémon Mart/Roads/Caves/Gift	350
X Speed	Increases speed (one battle)	Pokémon Mart/Caves	350

ITEMS TO SELL

ITEM	DESCRIPTION	LOCATION	PRICE
Big Mushroom	Can be sold at a Pokémon Mart	Trade/Wild	
Big Pearl	Can be sold for a high price	Goldenrod City/Trade/Wild	3,500
Brick Piece	Can be sold at a Pokémon Mart	Trade/Wild	
Gold Leaf	Can be sold at a Pokémon Mart	Trade/Wild	
Nugget	Can be sold for a high price	Roads/Caves/Gift/Goldenrod City	4,500
Pearl	Can be sold for a high price	Goldenrod City/Trade/Wild	650
Silver Leaf	Can be sold at a Pokémon Mart	Trade/Wild	
Star Piece	Can be sold for a high price	Goldenrod City/Trade/Wild	4,600
Star Dust	Can be sold for a high price	Goldenrod City/Trade/Wild	900
Slowpoke Tail	Can be sold for a high price	Mahogany Town	9,800
Tiny Mushroom	Can be sold for a low price	Mahogany Town/Trade/Wild	500

BALLS

ITEM	DESCRIPTION	LOCATION	PRICE
Fast Ball	Catches Pokémon that escape quickly	Azalea Town (Give Kurt White Apricorn)	
Friend Ball	Pokémon becomes very attached to you	Azalea Town (Give Kurt Green Apricorn)	
Great Ball	Catches Pokémon better than Poké Ball	Pokémon Mart/Roads/Caves/Gift	600
Heavy Ball	Easily catches heavy Pokémon	Azalea Town (Give Kurt Black Apricorn)	
Level Ball	Catches Pokémon at lower level than yours	Azalea Town (Give Kurt Red Apricorn)	
Love Ball	Easily catches opposite-sex Pokémon	Azalea Town (Give Kurt Pink Apricorn)	
Lure Ball	Makes fishing for Pokémon easy	Azalea Town (Give Kurt Blue Apricorn)	
Master Ball	Always catches Pokémon	Goldenrod City/New Bark Town	
Moon Ball	Catches Moon Stone-related Pokémon	Azalea Town (Give Kurt Yellow Apricorn)	
Poké Ball	Catches Pokémon	Pokémon Mart/Route 31	200
Ultra Ball	Catches Pokémon better than Great Ball	Pokémon Mart/Roads/Caves	1,200

ITEM LIST

MAIL

ITEM	DESCRIPTION	LOCATION	PRICE
Eon Mail	Paper w/Eevee's silhouette	Gift	
Flower Mail	Paper w/flower pattern	Violet/Azalea/Goldenrod/Saffron/Mahogany/Fuchsia	50
Liteblue Mail	Paper w/Dratini pattern	Vermilion City	50
Lovely Mail	Paper w/hearts	Celadon City	50
Morph Mail	Paper w/Ditto's silhouette	Gift	
Music Mail	Paper w/Natu pattern	Gift	
Portrait Mail	Prints any Pokémon	Mt. Moon	50
Surf Mail	Paper w/Lapras pattern	Olivine City/Cerulean City/Celadon City	50

DECORATIVE ITEMS

ITEM	DESCRIPTION	ITEM	DESCRIPTION
Big Lapras Doll	Mystery Gift	NES	Mystery Gift
Big Onix Doll	Mystery Gift	N64	Mystery Gift
Big Snorlax Doll	Mom's Shopping	Normal Box	Mystery Gift, Traded Pokemon
Blue Carpet	Mystery Gift	Oddish Doll	Mom's Shopping
Bulbasaur Doll	Mystery Gift	Pikachu Doll	Mom's Shopping
Charmander Doll	Mom's Shopping	Pikachu Poster	Mystery Gift
Clefairy Doll	Mom's Shopping	Pink Bed	Mystery Gift
Clefairy Poster	Mystery Gift	Poliwag Doll	Mom's Shopping
Diglett Doll	Mom's Shopping	Polkadot Bed	Mystery Gift
Feathery Bed	Have from the beginning	Red Carpet	Mystery Gift
Gengar Doll	Mom's Shopping	Shellder Doll	Mom's Shopping
Geodude Doll	Mom's Shopping	Silver Trophy	Traded Pokémon
Gold Trophy	Traded Pokemon	Squirtle Doll	Mom's Shopping
Gorgeous Box	Mystery Gift, Traded Pokemon	Staryu Doll	Mom's Shopping
Green Carpet	Mystery Gift	Super NES	Mystery Gift
Grimer Doll	Mom's Shopping	Surfing Pikachu Doll	Mystery Gift
Jigglypuff Doll	Mystery Gift	Town Map	Have from the beginning
Jigglypuff Poster	Mystery Gift	Tropicplant	Mystery Gift
Jumboplant	Mystery Gift	Virtual Boy	Mystery Gift
Machop Doll	Mom's Shopping	Voltorb Doll	Mom's Shopping
Magikarp Doll	Mom's Shopping	Weedle Doll	Mom's Shopping
Magnaplant	Mystery Gift	Yellow Carpet	Mystery Gift

TECHNICAL MACHINE LIST

TM	ABILITY	PLACE	PRICE	TM	ABILITY	PLACE	PRICE
01	Dynamic Punch	Cianwood City		26	Earthquake	Victory Road	
02	Headbutt	Ilex Forest/Goldenrod City	2,000	27	Return	Goldenrod City	
03	Curse	Celadon City		28	Dig	National Park	
04	Rollout	Route 35		29	Psychic	Saffron City/Celadon City	COIN 3,500
05	Roar	Route 32		30	Shadow Ball	Ecruteak City	
06	Toxic	Fuchsia City		31	Mud-Slap	Violet City	
07	Zap Cannon	Power Plant		32	Double Team	Celadon City	COIN 1,500
08	Rock Smash	Route 36/Goldenrod City	1,000	33	Ice Punch	Goldenrod City/Trade	3,000
09	Psych Up	Trade		34	Swagger	Lighthouse	
10	Hidden Power	Lake of Rage/Celadon City	3,000	35	Sleep Talk	Goldenrod City	
11	Sunny Day	Goldenrod City/Celadon City	2,000	36	Sludge Bomb	Route 43	
12	Sweet Scent	Route 34		37	Sand Storm	Route 27/Celadon City	2,000
13	Snore	Dark Cave/MooMoo Farm		38	Fire Blast	Goldenrod City	COIN 5,500
14	Blizzard	Goldenrod City	COIN 5,500	39	Swift	Union Cave	
15	Hyper Beam	Celadon City	COIN 7,500	40	Defense Curl	Mt. Mortar	
16	Icy Wind	Mahogany Town		41	Thunder Punch	Goldenrod City	3,000
17	Protect	Celadon City	3,000	42	Dream Eater	Viridian City	
18	Rain Dance	Slowpoke Well/Celadon City	2,000	43	Detect	Lake of Rage/Trade	
19	Giga Drain	Celadon City		44	Rest	Ice Path	
20	Endure	Burned Tower		45	Attract	Goldenrod City	
21	Frustration	Goldenrod City		46	Thief	Mahogany Town	
22	Solarbeam	Route 27		47	Steel Wing	Rock Tunnel/Route 28	
23	Iron Tail	Olivine City		48	Fire Punch	Goldenrod City	3,000
24	Dragonbreath	Dragon's Den		49	Fury Cutter	Azalea Town	
25	Thunder	Goldenrod City	COIN 5,500	50	Nightmare	Route 31	

HIDDEN MACHINE LIST

HM	ABILITY	PLACE	HM	ABILITY	PLACE
01	Cut	Ilex Forest	05	Flash	Sprout Tower
02	Fly	Cianwood City	06	Whirlpool	Rocket Hideout
03	Surf	Ecruteak City	07	Waterfall	Ice Path
04	Strength	Olivine City			

Special Attack

Physical Attack

ABILITIES & ATTACKS

ABILITY	TYPE	AT	AR	PP	EFFECT	TM/HM
Absorb	GRS	20	100	20	Restores your HP equal to half the damage caused to opponent	
Acid	PSN	40	100	30	10% chance of lowering defensive power by one level	
Acid Armor	PSN	-	-	40	Raises your defensive power by two levels	
Aeroblast	FLY	100	95	5	Good chance for a Critical Hit	
Agility	PSY	-	-	30	Raises your speed by 2 levels	
Amnesia	PSY	-	-	20	Raises your special defense by 2 levels	
Ancient Power	RCK	60	100	5	10% chance all abilities will rise one level	
Attract	NRM	-	100	15	50% chance of preventing opponent of opposite sex from attacking	45
Aurora Beam	ICE	65	100	20	10% chance of lowering opponent's attack power by one level	
Barrage	NRM	15	85	20	Attack 2-5 times consecutively in one turn	
Barrier	PSY	-	-	30	Raises your defensive power by two levels	
Baton Pass	NRM	-	-	40	Allows you to switch to another Pokémon during battle.	
Beat Up	DRK	10	100	10	Attack opponent a number of times equal to your number of healthy Pokémon	
Belly Drum	NRM	-	-	10	Raises attack power to maximum, and lowers HP by half	
Bide	NRM	-	100	10	Damage received is doubled and shot back at opponent for 2-3 turns	
Bind	NRM	15	75	20	Prevents escape, attacks opponent continuously for 2-5 turns	
Bite	DRK	60	100	25	10% chance of making opponent back off	
Blizzard	ICE	120	70	5	30% chance of freezing opponent	14
Body Slam	NRM	85	100	15	30% chance of paralyzing opponent	
Bone Club	GRD	65	85	20	10% chance of making opponent back off	
Bone Rush	GRD	25	80	10	Attack 2-5 times in a row in one turn	
Bonemerang	GRD	50	90	10	Attack twice in a row in one turn	
Bubble	WTR	20	100	30	10% chance of lowering opponent's speed by one level	
Bubblebeam	WTR	65	100	20	10% chance of lowering opponent's speed by one level	
Charm	NRM	-	100	20	Lowers opponent's attack power by two levels	
Clamp	WTR	35	75	10	Prevents escape, continuously attacks for 2-5 turns	
Comet Punch	NRM	18	85	15	Attack 2-5 times consecutively in one turn	
Confuse Ray	GHO	-	100	10	Confuses an opponent	
Confusion	PSY	50	100	25	10% chance of confusing an opponent	
Constrict	NRM	10	100	35	10% chance of lowering opponent's speed by one level	
Conversion	NRM	-	-	30	Changes your type into one of your attack types	
Conversion 2	NRM	-	100	30	Change your type into one that your opponent's attack is weak against	
Cotton Spore	GRS	-	85	40	Lowers opponent's speed by two levels	
Counter	FTG	-	100	20	Attack turn will be second, but doubles opponent's damage and shoots it back	
Crabhammer	WTR	90	85	10	Good Chance for a Critical Hit	
Cross Chop	FTG	100	80	5	Good chance for a Critical Hit	
Crunch	DRK	80	100	5	20% chance of lowering opponent's special defensive power by one level	
Curse	GHO	-	-	10	If a Ghost-type uses it, HP is lowered by 1/2 and opponent's HP drops every turn	03
Cut	NRM	50	95	30	Normal attack/Cut down small trees	HM 01
Defense Curl	NRM	-	-	40	Raises defense by one level	40
Destiny Bond	GHO	-	-	5	If Pokémon that uses this faints, opponent also faints	
Detect	FTG	-	-	5	Wards off attacks for one turn, success rate falls if used continuously	43
Dig	GRD	60	100	10	On first turn digs in ground, attacks on second turn/escape from caves	28
Disable	NRM	-	55	20	Opponent cannot use most recent attack for a number of turns	
Dizzy Punch	NRM	70	100	10	20% chance of confusing opponent	
Double Kick	FTG	30	100	30	Attacks twice in a row during one turn	
Double Team	NRM	-	-	15	Raises your evasion by one level	32
Double-edge	NRM	120	100	15	You receive 1/4 of the damage caused to opponent	

ABILITIES & ATTACKS

ABILITY	TYPE	AT	AR	PP	EFFECT	TM/HM
Double Slap	NRM	15	85	10	Attack 2-5 times in a row in one turn	
Dragonrage	DRG	-	100	10	Causes 40 points damage regardless of ability	
Dragonbreath	DRG	60	100	20	30% chance of paralyzing opponent	24
Dream Eater	PSY	100	100	15	While opponents sleep, steal HP equal to half the damage caused	42
Drill Peck	FLY	80	100	20	Normal attack	
Dynamicpunch	FTG	100	50	5	If attack hits, opponent will be confused	01
Earthquake	GRD	100	100	10	Normal attack	26
Egg Bomb	NRM	100	75	10	Normal attack	
Ember	FIR	40	100	25	Burns opponent	
Encore	NRM	-	100	5	Forces opponent to use the attack it used most recently 2-6 times	
Endure	NRM	-	-	10	Even if hit you'll be left with one HP, rate of success drops if used continuously	20
Explosion	NRM	250	100	5	After using it, you will faint	
Extreme Speed	NRM	80	100	5	Always strikes first	
Faint Attack	DRK	60	-	20	Attack will always hit	
False Swipe	NRM	40	100	40	Always leaves opponent with 1 HP	
Fire Blast	FIR	120	85	5	10% chance of burning opponent	38
Fire Punch	FIR	75	100	15	10% chance of burning opponent	48
Fire Spin	FIR	15	70	15	Prevents escape/Attack continuously for 2-5 turns	
Fissure	GRD	-	30	5	Opponents faint in one shot if hit	
Flail	NRM	-	100	15	The lower your remaining HP, the more damage caused to opponent	
Flame Wheel	FIR	60	100	25	10% chance of burning opponent, ice is melted if opponent is frozen	
Flame Thrower	FIR	95	100	15	10% chance of burning opponent	
Flash	NRM	-	70	20	Lowers an opponent's accuracy one level/lights up dark places	HM 05
Fly	FLY	70	95	15	Fly up on first turn, attack on second/fly back to places you already visited	HM 02
Focus Energy	NRM	-	-	30	Attack used following this will have a good chance for a Critical Hit	
Foresight	NRM	-	100	40	Returns evasion rate to normal, Normal- and Fighting-types hit Ghost-types	
Frustration	NRM	-	100	20	Power of attack increases based on attachment of Pokémon to its Trainer	21
Fury Attack	NRM	15	85	20	Attack 2-5 times in a row in one turn	
Fury Cutter	BUG	10	95	20	Power of attack doubles every time it's used until you miss	49
Fury Swipes	NRM	18	80	15	Attack 2-5 times in a row in one turn	
Future Sight	PSY	80	90	15	Attacks opponent after 2 turns	
Giga Drain	GRS	60	100	5	Restores your HP equal to half of the damage caused to opponent	19
Glare	NRM	-	75	30	Paralyzes opponent	
Growl	NRM	-	100	40	Lowers opponent's attack power by one level	
Growth	GRS	-	-	40	Raises your special attack by one level	
Guillotine	NRM	-	30	5	If attack hits, opponent will be defeated by one hit	
Gust	FLY	40	100	35	Normal attack	
Harden	NRM	-	-	30	Raises your defensive power by one level	
Haze	ICE	-	-	30	Recovers your and opponent's abilities to normal	
Headbutt	NRM	70	100	15	30% chance of making an opponent back off /shakes trees	02
Heal Bell	NRM	-	-	5	Cures all your Pokémon of bad conditions	
Hi Jump Kick	FTG	85	95	20	If attack misses, receive 1/8 of damage it would have caused	
Hidden Power	NRM	-	100	15	Power and attack type vary depending on the Pokémon that uses it	10
Horn Attack	NRM	65	100	25	Normal attack	
Horn Drill	NRM	-	30	5	One hit will make opponent faint	
Hydro Pump	WTR	120	80	5	Normal attack	
Hyper Beam	NRM	150	90	5	Pokémon can't attack on next turn	15
Hyper Fang	NRM	80	90	15	10% chance of making an opponent back off	
Hypnosis	PSY	-	60	20	Makes opponent fall asleep	
Ice Beam	ICE	95	100	10	10% chance of freezing opponent	

ABILITIES & ATTACKS

ABILITY	TYPE	AT	AR	PP	EFFECT	TM/HM
Ice Punch	ICE	75	100	15	10% chance of freezing an opponent	33
Icy Wind	ICE	55	95	15	If attack hits it lowers opponent's speed by one level	16
Iron Tail	STL	100	75	15	30% chance of lowering opponent's defense one level	23
Jump Kick	FTG	70	95	25	If attack misses, receive 1/8 of damage that it would have caused	
Karate Chop	FTG	50	100	25	Good chance for a Critical Hit	
Kinesis	PSY	-	80	15	Lowers opponent's accuracy by one level	
Leech Life	BUG	20	100	15	Restores your HP equal to half of the damage caused to opponent	
Leech Seed	GRS	-	90	10	Steals HP and restores your HP on every turn, even if Pokémon is substituted	
Leer	NRM	-	100	30	Lowers opponent's defense by one level	
Lick	GHO	20	100	30	30% chance of paralyzing opponent	
Light Screen	PSY	-	-	30	Special attack damage halved for 5 turns, even for substituted Pokémon	
Lock-on	NRM	-	100	5	Attack on next turn will always hit	
Lovely Kiss	NRM	-	75	15	Makes an opponent sleep	
Low Kick	FTG	50	90	20	30% chance of making an opponent back off	
Mach Punch	FTG	40	100	30	Always strike first	
Magnitude	GRD	-	100	30	Changes power to 10, 30, 50, 70, 90, 110 or 150	
Mean Look	NRM	-	100	5	Opponent cannot escape while the Pokémon that used it is in battle	
Meditate	PSY	-	-	40	Raises your attack power by one level	
Mega Drain	GRS	40	100	10	Restores HP equal to half of damage caused by opponent	
Mega Kick	NRM	120	75	5	Normal attack	
Mega Punch	NRM	80	85	20	Normal attack	
Megaphone	BUG	120	85	10	Normal attack	
Metal Claw	STL	50	95	35	10% chance of raising your attack power by one level	
Metronome	NRM	-	-	10	Randomly uses an attack from entire repertoire	
Milk Berry	NRM	-	-	10	Restores half of HP/splits 1/5 of HP among your other Pokémon	
Mimic	NRM	-	100	10	Copies opponent's attack and uses it during that battle, must attack second	
Mind Reader	NRM	-	100	5	Next attack will always hit	
Minimize	NRM	-	-	20	Raises your evasion by one level	
Mirror Coat	PSY	-	100	20	Your attack will be second, double opponent's special attack power and shoot it back	
Mirror Move	FLY	-	-	20	Uses same attack opponent did	
Mist	ICE	-	-	30	Keeps attacks that lower abilities from working	
Moon Light	NRM	-	-	5	Restores HP/effect depends on the time of day	
Morning Sun	NRM	-	-	5	Restores HP/effect depends on the time of day.	
Mud-Slap	GRD	20	100	10	Lowers opponent's accuracy by one level	31
Night Shade	GHO	-	100	15	Causes damage equal to your level, regardless of ability	
Nightmare	GHO	-	100	15	Gives an opponent nightmares, works only when opponent is asleep	50
Octazooka	WTR	65	85	10	50% chance of lowering opponent's accuracy by one level	
Outrage	DRG	90	100	15	Attack continuously for 2-3 turns, become confused once effects wear off	
Pain Split	NRM	-	100	20	Combines your HP with opponent's HP and splits them between you	
Pay Day	NRM	40	100	20	After a battle receive money equal to (your level) x (number of attacks) x 2	
Peck	FLY	35	100	35	Normal attack	
Perish Song	NRM	-	-	5	Both Pokémon faint after 3 turns, substitution cancels the effect	
Petal Dance	GRS	70	100	20	Attack for 2-3 turns in a row, become confused once it wears off	
Pin Missile	BUG	14	85	20	Attack 2-5 times in a row in one turn	
Poison Gas	PSN	-	55	40	Poisons an opponent	
Poison Sting	PSN	15	100	35	30% chance of poisoning an opponent	
Poisonpowder	PSN	-	75	35	Poisons an opponent	
Pound	NRM	40	100	35	Normal attack	
Powder Snow	ICE	40	100	25	10% chance of freezing an opponent	
Present	NRM	-	90	15	May cause damage of 40, 80, 120 or may restore HP by 80	
Protect	NRM	-	-	10	Ward off opponent's attack for one turn, success rate falls if used continuously	17

ABILITIES & ATTACKS

ABILITY	TYPE	AT	AR	PP	EFFECT	TM/HM
Psybeam	PSY	65	100	20	10% chance of confusing an opponent	
Psych Up	NRM	-	-	10	The helpful attacks your opponent uses also help you	09
Psychic	PSY	90	100	10	10% chance of lowering opponent's special defense power by one level	29
Psywave	PSY	-	80	15	Power changes randomly—minimum value is one, maximum is your level x 1.5	
Pursuit	DRK	40	100	20	Double damage to Pokémon if withdrawn while attack is in effect	
Quick Attack	NRM	40	100	30	Always attacks first	
Rage	NRM	20	100	20	If used consecutively, attack power increases when opponent's attack hits	
Rain Dance	WTR	-	-	5	Raise Water-type attack power for 5 turns	18
Rapid Spin	NRM	20	100	40	Escape from attacks multiple turns	
Razor Leaf	GRS	55	95	25	Good chance for a Critical Hit	
Razor Wind	NRM	80	75	10	Good chance for a Critical Hit	
Recover	NRM	-	-	20	Restores half of your maximum HP	
Reflect	PSY	-	-	20	Damage from attacks cut in half for 5 turns, even if Pokémon are substituted	
Rest	PSY	-	-	10	Restores all HP but puts you to sleep for 2 turns	44
Return	NRM	-	100	20	Power of attack increases with level of attachment of Pokémon to you	27
Reversal	FTG	-	100	15	The lower your remaining HP, the more damage it causes	
Roar	NRM	-	100	20	Ends battle with wild Pokémon, forces substitution in Trainer battle	05
Rock Slide	RCK	75	90	10	30% chance of making an opponent back off	
Rock Smash	FTG	20	100	15	50% chance of lowering opponent's defense by 1 level/breaks rocks	08
Rock Throw	RCK	50	90	15	Normal attack	
Rolling Kick	FTG	60	85	15	30% chance of making an opponent back off	
Rollout	RCK	30	90	20	Attacks continuously for 5 turns with increasing damage/ends if attack misses	04
Sacred Fire	FIR	100	95	5	50% chance of burning an opponent	
Safeguard	NRM	-	-	25	Prevents poison attacks for 5 turns, even if Pokémon are substituted	
Sand Storm	RCK	-	-	10	Causes damage to both Pokémon every turn, not Rock-, Steel- or Ground-types	37
Sand-Attack	GRD	-	100	15	Lowers opponent's accuracy by one level	
Scary Face	NRM	-	90	10	Lowers opponent's speed by 2 levels	
Scratch	NRM	40	100	35	Normal attack	
Screech	NRM	-	85	40	Lowers opponent's defense by 2 levels	
Seismic Toss	FTG	-	100	20	Causes damage equal to your level, regardless of ability	
Selfdestruct	NRM	200	100	5	After using, you will faint	
Shadow Ball	GHO	80	100	15	20% chance of lowering an opponent's special defense by one level	30
Sharpen	NRM	-	-	30	Raises your attack power by one level	
Sing	NRM	-	55	15	Makes an opponent sleep	
Sketch	NRM	-	-	1	Replaces itself with the opponent's last attack, which remains after the battle	
Skull Bash	NRM	100	100	15	Builds up for one turn, attacks on second, defense increased by 1 level	
Sky Attack	FLY	140	90	5	Builds up for one turn and attacks on second, good chance for a Critical Hit	
Slam	NRM	80	75	20	Normal attack	
Slash	NRM	70	100	20	Good chance for a Critical Hit	
Sleep Powder	GRS	-	75	15	Puts opponent to sleep	
Sleep Talk	NRM	-	-	10	Attack randomly while sleeping	35
Sludge	PSN	65	100	20	30% chance of poisoning an opponent	
Sludge Bomb	PSN	90	100	10	30% chance of poisoning an opponent	36
Smog	PSN	20	70	20	40% chance of poisoning an opponent	
Smokescreen	NRM	-	100	20	Lowers opponent's accuracy by 1 level	
Snore	NRM	40	100	15	30% chance of making an opponent back off, but you must be asleep	13
Softboiled	NRM	-	100	10	Restores half HP/gives 1/5 of Chansey's HP to another of your Pokémon	
Solarbeam	GRS	120	100	10	Build up for one turn and attack on the second	22
Sonicboom	NRM	-	90	20	Causes 20 points of damage regardless of ability	
Spark	ELC	65	100	20	30% chance of paralyzing opponent	
Spider Web	BUG	-	100	10	Prevents escape/prevents substitutions in Trainer battles	

ABILITIES & ATTACKS

ABILITY	TYPE	AT	AR	PP	EFFECT	TM/HM
Spike Cannon	NRM	20	100	15	Attack 2-5 times consecutively in one turn	
Spikes	GRD	-	-	20	Causes damage every time opponent substitutes a Pokémon	
Spite	GHO	-	100	10	Lowers PP of opponent's last attack by 2-5	
Splash	NRM	-	-	40	No effect	
Spore	GRS	-	100	15	Makes an opponent sleep	
Steel Wing	STL	70	90	25	10% chance of raising your defensive power	47
Stomp	NRM	65	100	20	30% chance of making an opponent back off	
Strength	NRM	80	100	15	Normal attack/moves rocks	HM 04
String Shot	BUG	-	95	40	Lowers opponent's speed by 1 level	
Struggle	NRM	50	100	1	If used once all PP points are gone, you receive 1/4 of opponent's damage	
Stun Spore	GRS	-	75	30	Paralyzes opponent	
Submission	FTG	80	80	25	Receive 1/4 of damage caused to opponent	
Substitute	NRM	-	-	10	Uses 1/4 of maximum HP value and creates a decoy to take damage	
Sunny Day	FIR	-	-	5	Raises power of Fire-type attacks for 5 turns	11
Super Fang	NRM	-	90	10	Knocks opponent's HP to half	
Supersonic	NRM	-	55	20	Confuses an opponent	
Surf	WTR	95	100	15	Normal attack/can move across water	HM 03
Swagger	NRM	-	90	15	Confuses an opponent but raises its attack by 2 levels	34
Sweet Kiss	NRM	-	75	10	Confuses an opponent	
Sweet Scent	NRM	-	100	20	Lowers an opponent's ability to evade by 1 level/makes wild Pokémon appear	12
Swift	NRM	60	-	20	Attack will always hit	39
Swords Dance	NRM	-	-	30	Raises your attack power by 2 levels	
Synthesis	GRS	-	-	5	Restores HP/effects depend on time of day	
Tackle	NRM	35	95	35	Normal attack	
Tail Whip	NRM	-	100	30	Lowers opponent's defensive power by one level	
Take Down	NRM	90	85	20	Receive 1/4 of damage caused to opponent	
Teleport	PSY	-	-	20	Can escape from wild battles/Go to the last Pokémon Center you visited	
Thief	DRK	40	100	10	Steals wild Pokémon's item/normal attack if it's not holding an item	46
Thrash	NRM	90	100	20	Attack for 2-3 turns successively, become confused once effects wear off	
Thunder	ELC	120	70	10	30% chance of paralyzing an opponent	25
Thunder Wave	ELC	-	100	20	Paralyzes an opponent	
Thunderbolt	ELC	95	100	15	10% chance of paralyzing an opponent	
Thunderpunch	ELC	75	100	15	10% chance of paralyzing an opponent	41
Thundershock	ELC	40	100	30	10% chance of paralyzing an opponent	
Toxic	PSN	-	85	10	Poisons an opponent, damage increases each turn	06
Transform	NRM	-	-	10	Change to same Pokémon as opponent with same attacks, all PP at 5	
Tri Attack	NRM	80	100	10	20% chance of either freezing, burning or paralyzing an opponent	
Triple Kick	FTG	10	90	10	Attacks 3 times in a row, damage increases each time	
Twineedle	BUG	25	100	20	Attacks twice in a row during one turn, 20% chance of poisoning opponent	
Twister	DRG	40	100	20	20% chance of making an opponent back off	
Vicegrip	NRM	55	100	30	Normal attack	
Vine Whip	GRS	35	100	10	Normal attack	
Vital Throw	FTG	70	100	10	Independent of speed, attack turn will be second but a sure hit	
Water Gun	WTR	40	100	25	Normal attack	
Waterfall	WTR	80	100	15	Normal attack/can climb up waterfalls	HM 07
Whirlpool	WTR	15	70	15	Prevents escape, continuously attack for 2-5 turns/can cross over whirlpools	HM 06
Whirlwind	NRM	-	100	20	Ends battles with wild Pokémon, forces substitution in Trainer battles	
Wing Attack	FLY	60	100	35	Normal attack	
Withdraw	WTR	-	-	40	Raises your defensive power by one level	
Wrap	NRM	15	85	20	Prevents escape and lets you attack continuously for 2-5 turns	
Zap Cannon	ELC	100	50	5	If you hit an opponent it will always be paralyzed	07

Pokémon Locator

Pokémon are very territorial, so you won't just find them wandering out and about in random locations. Instead, you'll find them in very specific areas. The chart below lists the Pokémon you can catch in the

game and where you should look for them. Locations colored in black indicate wild Pokémon. Areas colored in red indicate that you can collect the local Pokémon through a special situation that will occur there.

POKÉMON	AREA	POKÉMON	AREA
ABRA	ROUTE 34, ROUTE 35, GOLDENROD CITY	PARAS	ILEX FOREST, NATIONAL PARK
AERODACTYL	ROUTE 14	PIDGEOTTO	ROUTE 37
BEEDRILL	NATIONAL PARK	PIDGEY	ROUTE 29, ROUTE 30, ROUTE 31, ROUTE 35, ROUTE 36, ROUTE 37, NATIONAL PARK
BELLSPOUR	ROUTE 31, ROUTE 32	PINSIR	NATIONAL PARK
BUTTERFREE	NATIONAL PARK	PORYGON	CELADON CITY
CATERPIE	ROUTE 30, ROUTE 31, ILEX FOREST, NATIONAL PARK	RAPIDASH	PEWTER CITY
CHIKORITA	NEW BARK TOWN	RATICATE	BURNED TOWER
CYNDQUIL	NEW BARK TOWN	RATTATA	ROUTE 29, ROUTE 30, ROUTE 31, ROUTE 32, ROUTE 33, ROUTE 34, SPROUT TOWER, UNION CAVE, BURNED TOWER
DITTO	ROUTE 34, ROUTE 35	RHYDON	BLACKTHORN CITY
DRATINI	GOLDENROD CITY, DRAGON DEN	SANDSHREW	UNION CAVE (GOLD), GOLDENROD CITY (SILVER)
DROWZEE	ROUTE 34, ROUTE 35	SCYTHYR	NATIONAL PARK
EEVEE	GOLDENROD CITY, CELADON CITY	SENTRET	ROUTE 29
EKANS	ROUTE 32 (SILVER), ROUTE 33 (SILVER), GOLDENROD CITY (GOLD)	SHUCKLE	CIANWOOD CITY
GASTLY	SPROUT TOWER	SLOWPOKE	SLOWPOKE WELL
GEODUDE	UNION CAVE	SNORLAX	VERMILION CITY
GOLBAT	SLOWPOKE WELL	SPEAROW	ROUTE 33
GROWLITHE	ROUTE 36, ROUTE 37 (GOLD ONLY)	SPINARAK	ROUTE 30, ROUTE 31, ROUTE 37 (GOLD ONLY)
HO-OH	TIN TOWER	STANTLER	ROUTE 36, ROUTE 37
HOOTHOOT	ROUTE 29, ROUTE 30, ROUTE 31, ROUTE 35, ROUTE 36, ROUTE 37, NATIONAL PARK	SUDOWOODO	ROUTE 36
HOPPIP	ROUTE 32, ROUTE 33	SUNKERN	NATIONAL PARK
KAKUNA	ROUTE 30, ROUTE 31, ILEX FOREST, NATIONAL PARK	TOGEPI	VIOLET CITY
KOFFING	BURNED TOWER	TOTODILE	NEW BARK TOWN
LAPRAS	UNION CAVE	TYROGUE	MT. MORTAR
LEDYBA	ROUTE 30, ROUTE 31, ROUTE 37 (SILVER ONLY)	UNOWN	RUINS OF ALPH
LUGIA	WHIRL ISLAND	VENONAT	NATIONAL PARK
MACHOP	GOLDENROD CITY	VOLTORB	OLIVINE CITY, ROUTE 10
MAGMAR	BURNED TOWER	VULPIX	ROUTE 36, ROUTE 37 (SILVER ONLY)
MAREEP	ROUTE 32	WEEDLE	ROUTE 30, ROUTE 31, ILEX FOREST, NATIONAL PARK
METAPOD	ROUTE 30, ROUTE 31, ILEX FOREST, NATIONAL PARK	WOOPER	ROUTE 32
MR. MIME ♀	CELADON CITY	ZUBAT	ROUTE 32, ROUTE 33, UNION CAVE, SLOWPOKE WELL, ILEX FOREST, BURNED TOWER
NIDORAN ♂	ROUTE 35, ROUTE 36		
NIDORAN	ROUTE 35, ROUTE 36		
ODDISH	ILEX FOREST		
ONIX	VIOLET CITY, UNION CAVE		

COLOR KEY
WILD POKÉMON
EVENT-RELATED POKÉMON

POKÉMON COMBAT CHART

In combat, type matters. The Pokémon's type and the attack type it's using and the type of Pokémon the attack is used against all factor in to the amount of damage an attack will do. The chart shows how attack types measure up against Pokémon types. For example, a Dark-type attack will do half the usual damage when used on a Fighting-type Pokémon, while a Ghost-type attack will have no effect on Normal-types.

ATTACK Attack measures the power of physical attacks, which appear in orange on the chart.

SPECIAL Nonphysical attacks and your defense against them are measured by the Special rating. Special attacks appear in blue on the chart.

x2 Damage for + attacks

x2 "Critical Hit" damage

x1.5 Attack type is the same type as the Pokémon that's using it

x0.5 Damage for - attacks

x0 Damage for = attacks



YOUR ATTACK TYPE

		OPONENT'S POKÉMON TYPE																
		NORMAL	FIRE	WATER	ELECTRIC	GRASS	ICE	FIGHTING	POISON	GROUND	FLYING	PSYCHIC	BUG	ROCK	GHOST	DRAGON	DARK	STEEL
YOUR ATTACK TYPE	NORMAL														=			-
	FIRE	-	-			+	+						+	-				+
	WATER	+	-			-				+				+		-		
	ELECTRIC			+	-	-				=	+					-		
	GRASS																	
	ICE	-	+			-				+	-			+		-		-
	FIGHTING	+						+		-		-	-	+	=		+	+
	POISON					+				-	-				-	-		=
	GROUND		+			+	-			+		=		-	+			+
	FLYING							+						+	-			-
	PSYCHIC								+	+			-				=	-
	BUG												+				+	-
	ROCK		+					+	-		-	+		+				-
	GHOST	=											+			+		-
	DRAGON																+	-
	DARK								-				+			+		-
	STEEL		-	-	-			+							+			-

POKÉMON INDEX

The list to the right shows the Player's Guide page numbers where you can find info on the Pokémon from the game. Pokémon names colored in green are new Pokémon, and if you flip to their page number, you'll find their stats detailed in a chart like the one explained below.

#161 SENTRET TYPE: NORMAL

The Pokémon's evolution is shown below its name, so a Sentret (#161) will evolve into a Furret (#162) when it reaches level 15.

LEVEL 15 #162 FURRET NRM

Attacks

QUICK ATTACK
SLAM
REST
AMNESIA

HMs

CUT
SURF
STRENGTH (#162)



ATTACKS

The list of attacks is the recommended arsenal for the profiled Pokémon. Some attacks, like Strength in the example above, can be learned only after your Pokémon evolves.

HMs

To learn some attacks and HMs, a Pokémon may have to evolve to a new form, the number of which will appear in parentheses.

ORIGINAL POKÉMON

NEW POKÉMON

NAME	PAGE	NAME	PAGE	NAME	PAGE
ABRA	64	GEODUDE	48	MAGIKARP	30
ALAKAZAM	64	GLOOM	66	MAGNEMITE	41
AMPHAROS	26	GOLBAT	28	MAGNETON	41
ARCANINE	65	GOLDFIN	48	MAREEP	26
ARIADOS	53	GOLEM	48	MEGANIUM	21
BAYLEEF	21	GRAVELER	48	MEOWTH	65
BELLOSSOM	66	GRIMER	72	MUK	72
BELLSPROUT	54	GROWLITHE	65	NINETALES	70
BLISSEY	74	HYPNOSIS	44	NOCTOWL	75
CHANSEY	74	GYARADOS	25	ODDISH	66
CHIKORITA	21	HAUNTER	57	SUNKERN	28
CROBAT	28	HERACROSS	75	TANGELA	54
CROCONAW	21	HOOTHOOT	75	TAUROS	41
CYNDQUIL	21	HOPPIP	27	TENTACOO	44
DITTO	66	HORSEA	45	TENTACRUEL	44
DROWZEE	74	HYPNO	74	TOGEPI	54
EVEE	34	JIGGLYPUFF	78	TOGETIC	54
ELECTRODE	42	JOLTEON	34	TOTODILE	21
ESPEON	34	JUMPLUFF	27	TYPHLOSION	21
FARFETCH'D	41	JYKX	54	UMBREON	34
FEAROW	47	KADABRA	64	VAPOREON	34
FERALIGATR	21	KINGDRA	45	VENOMOTH	69
FLAUFFY	26	KINGLER	44	VENONAT	69
FLAREON	34	KOFFING	51	VICTREEBEL	54
FORRETRESS	54	KRABBY	44	VILEPLUME	66
FURRET	120	LAPRAS	28	VOLTORB	42
GASTLY	25	LEDIAN	53	VULPIX	70
GENGAR	25	LEDYBA	53	WEEPINBELL	54
		LICKITUNG	54	WEEZING	51
		MACHOP	48	WIGGLYTUFF	78
		MACHOPKE	48	WOOPER	27
		MACHOP	48	ZUBAT	28

Take a lesson from the Professor—get a subscription to Nintendo Power!

Good Trainers never stop learning, and subscribing to Nintendo Power is one of the best ways to keep up on Pokémon strategies, tricks and teams! Nintendo Power's **POKéCENTER** features breaking news, strategies for all the Pokémon games and much more!

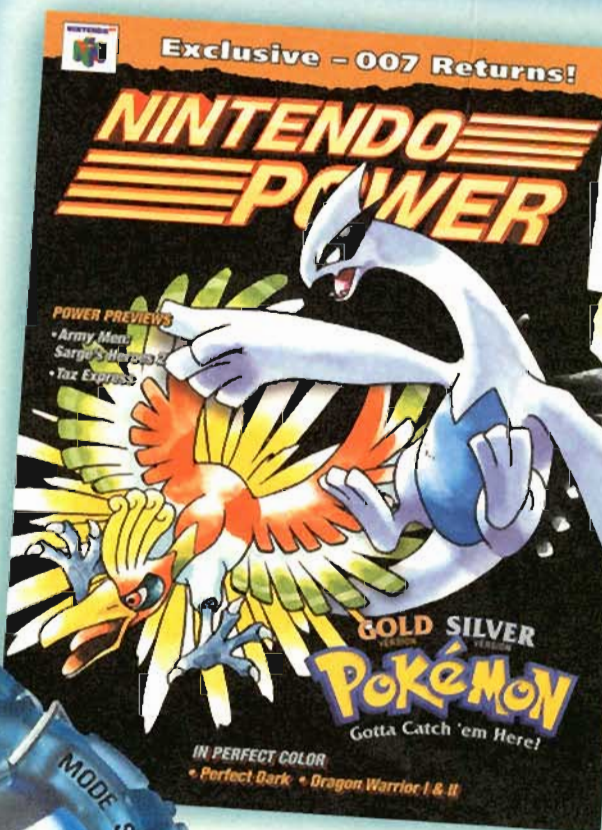

Free watch with paid subscription!

Perfect Timing

Nintendo Power has the precious info you crave on all the coolest games for the Nintendo 64 and Game Boy. You gotta catch it!

A one-year subscription to Nintendo Power is only \$19.95*, and if you mention offer #4196, we'll send you a watch, too. This is the best time for you to get your subscription!

Call 1-800-255-3700 to order your subscription today!

*Canadian subscribers pay \$27.95. Prices are subject to change without notice. Please allow 4-6 weeks for delivery. Merchandise offer good while supplies last. Only VISA or Mastercard accepted with phone orders.

Pokémon

Gold Version Silver Version

The Pokémon Masters at Nintendo Power have dug up a treasure trove of insider information on the newest Pokémon adventures. The Pokémon Gold Version and Silver Version guide contains information on the new places, people and Pokémon that make Gold and Silver the most precious Pokémon Paks to date!



COMPLETE WALK-THROUGH

Take a guided tour of all the routes, towns, islands, caves and cities in Pokémon Gold Version and Silver Version, complete with in-depth info on what to see and do while you're in each area.

CATCH 'EM GUIDE

Learn how to catch many of the most difficult Pokémon with tips on evolution, stones, items and eggs.

BATTLE STRATEGIES

Find out which Pokémon to take into each battle with your Rival, the Gym Leaders, the Elite Four and more!

DETAILED MAPS

Keep track of your progress and always know where you're going with our detailed maps.



0 45496 69182 0



\$14.99 U.S. / \$17.99 Canada

ISBN 1-930206-04-6

51499 >



9 781930 206045