PRINCIPLES OF FIREARMS

— CHARLES E. BALLEISEN —

MAJOR, ORDNANCE DEPARTMENT

— ARMY OF THE UNITED STATES —

Feel free to send me patches & shit
kommandobooks@mail.com
/K's book guy

Information Deserves To Be Free

NEW YORK - JOHN WILEY AND SONS, INC.

LONDON - CHAPMAN AND HALL, LIMITED





THIS BOOK HAS BEEN MANUFACTURED IN ACCORDANCE WITH THE RECOMMENDATIONS OF THE WAR PRODUCTION BOARD IN THE INTEREST OF THE CONSERVATION OF PAPER AND OTHER IMPORTANT WAR MATERIALS.

COPYRIGHT, 1945
BY
CHARLES E. BALLEISEN

All Rights Reserved

This book or any part thereof must not be reproduced in any form without the written permission of the publisher.



PRINTED IN THE UNITED STATES OF AMERICA

PREFACE

The purpose of this book is to expound the concept that an automatic firearm is a piece of machinery operating in accordance with well-known laws of physics and hence capable of being analyzed and designed in accordance with common engineering practice. This approach to the subject is believed to be new in this country, although much similar material has been published in France and Germany. Thus, the source material available in this country to engineers who are called upon to design weapons is either in the French or German language or exists in only very limited quantities.

In accordance with the purpose stated, this book is neither a catalogue nor a historical register of automatic weapons. Many excellent books of those types are already in existence. The treatment, rather, has been to select a limited number of familiar weapons and to analyze their operation from the viewpoint of a mechanical engineer. In this initial work, the selection has necessarily been limited and the treatment of the subject is, of course, hampered by the lack of any other domestic works which could have been used as guides.

Strictly speaking, there is little original material in the following pages. In fact, the basis for the clearance for publication of this information has been that the data involved are undoubtedly known to our present enemies and are such as could be noted, deduced, or otherwise obtained by any competent engineer working in the field. In this respect, it should be particularly noted that the opinions contained herein are those of the author and do not in any way represent official views of the United States Army or of the Ordnance Department thereof.

Grateful acknowledgment is made to those prior authors who have permitted me to quote from their works. Indi-

vidual acknowledgments are made throughout the book wherever the quotations appear. Likewise, the author wishes to express his appreciation to those of his associates and leaders whose kind encouragement for several years has opened the sources of this material and provided for its development. Only because of their numbers and, in some cases, their personal requests to remain anonymous is it possible to complete this paragraph without a long list of those who have thus contributed to this book. It is not possible, however, to close without mentioning the capable and generous services of my devoted wife, who has constantly maintained me at my task and who personally prepared the manuscript for the publishers.

CHARLES E. BALLEISEN

Arlington, Va.
January 1945.

CONTENTS

<i>Chapter One.</i> INTRODUCTION		PAGE
1.1	DEFINITIONS	1
1.2	AMMUNITION	2
1.3	HISTORICAL	3
1.4	ENGINEERING UNITS	4
1.5	SYMBOLS AND ABBREVIATIONS	4
1.6	BIBLIOGRAPHIES	5
<i>Chapter Two.</i> THE GUN BARREL		
2.1	INTRODUCTION	7
2.2	INTERIOR BALLISTICS	7
2.3	STRENGTH COMPUTATIONS	11
2.4	VIBRATIONS	13
2.5	RIFLING	14
2.6	BARREL HEATING	17
2.7	TAPERED BORE BARRELS	20
<i>Chapter Three.</i> RECOIL		
3.1	INTRODUCTION	22
3.2	FREE RECOIL DUE TO BULLET MOTION	22
3.3	FREE RECOIL DUE TO GAS MOTION	24
3.4	RETARDED RECOIL	25
3.5	RECOIL BRAKES	25
<i>Chapter Four.</i> AUTOMATIC WEAPONS—FUNCTIONS		
4.1	INTRODUCTION	29
4.2	FEEDING	29
4.3	OBTURATING	31
4.4	FIRING	31
4.5	EXTRACTING	34
4.6	EJECTING	36
4.7	COCKING	38

<i>Chapter Five. AUTOMATIC WEAPONS—SYSTEMS</i>		PAGE
5.1	INTRODUCTION	39
5.2	INERTIA	40
5.3	DELAYED INERTIA	42
5.4	SHORT RECOIL	43
5.5	LONG RECOIL	45
5.6	GAS OPERATION	46
5.7	COMPOUND SYSTEMS	51
<i>Chapter Six. AUTOMATIC WEAPONS—EXISTING TYPES</i>		
6.1	INERTIA WEAPONS—THE M3 SUBMACHINE GUN	52
6.2	RECOIL-OPERATED WEAPONS—THE BROWNING MACHINE GUN	54
6.3	RECOIL-OPERATED WEAPONS—THE MAUSER MACHINE GUN, MG151	61
6.4	GAS-OPERATED WEAPONS—THE JAPANESE LIGHT MACHINE GUN, MODEL 99	65
6.5	COMPOSITE SYSTEMS—THE HISPANO-SUIZA AUTOMATIC CANNON	67
<i>Chapter Seven. TRIGGER AND SEAR MECHANISMS</i>		
7.1	INTRODUCTION	70
7.2	FUNCTIONING REQUIREMENTS	71
7.3	FULL AUTOMATIC MECHANISMS	72
7.4	SEMI-AUTOMATIC MECHANISMS	75
7.5	CONVERTIBLE MECHANISMS	76
<i>Chapter Eight. CARTRIDGE FEEDS</i>		
8.1	INTRODUCTION	78
8.2	MAGAZINES	79
8.3	BELTS	80
8.4	STRIPS	82
8.5	CLIPS	83
8.6	CHARGERS	84
8.7	HOPPERS	85

<i>Chapter Nine. SIGHTS</i>		PAGE
9.1	INTRODUCTION	86
9.2	IRON SIGHTS	86
9.3	FRONT SIGHTS	88
9.4	REAR SIGHT APERTURES	91
9.5	REAR SIGHT STRUCTURES	92
9.6	COMPUTING SIGHTS	94
9.7	OPTICAL SIGHTS	95
<i>Chapter Ten. DESIGN PROBLEMS</i>		
10.1	INTRODUCTION	97
10.2	BORE EROSION	97
10.3	GAS PORT EROSION	101
10.4	CORROSION	101
10.5	LUBRICATION	104
10.6	CLIMATIC EXPANSION	104
10.7	DIRT STOPPAGES	105
10.8	MALFUNCTIONS	106
10.9	BREAKAGES	108
10.10	SPRINGS	108
<i>Chapter Eleven. THE TESTING OF WEAPONS</i>		
11.1	INTRODUCTION	111
11.2	PRESSURE—MEASUREMENT BY COPPERS	111
11.3	PRESSURE—MEASUREMENT ELECTRICALLY	113
11.4	VELOCITY	115
11.5	ACCURACY	121
11.6	FUNCTIONING	123
11.7	PENDULUM MEASUREMENTS	127
<i>Appendix A. EXTERIOR BALLISTICS</i>		
A.1	INTRODUCTION	131
A.2	AIR RESISTANCE	131
A.3	APPROXIMATE COMPUTATION OF A TRAJECTORY	133
A.4	MOTION OF THE PROJECTILE ABOUT THE TRAJECTORY	134

Appendix B. GUN MOUNTS

	PAGE
B·1 INTRODUCTION	136
B·2 STABILITY	136
B·3 FIELD OF FIRE	139
B·4 STRUCTURE	140
<i>Index</i>	141

CHAPTER ONE

INTRODUCTION

1·1 DEFINITIONS

A *firearm* is a device which propels a missile, such propulsion being obtained through the combustion of a fuel within the device. The word *gun* is synonymous with *firearm*.

A firearm is basically described by the *diameter of its bore*, which corresponds to the size of the projectile. This diameter is used as a measuring unit called a *caliber*. Thus a gun firing shells 4 in. in diameter has a caliber of 4 in. This unit is commonly used to designate the length of a gun barrel. For example, if the same gun had a barrel $4 \times 50 = 200$ in. long, it would be described as a 4-in. 50-caliber gun. This usage is somewhat confused in guns of small caliber, where the bore diameter is placed after the word *caliber*, such as *Caliber .50* to designate a gun having a $\frac{1}{2}$ -in. bore. This term is often heard as 50 caliber, conflicting with the definition given. For clarity, it is best to distinguish between the two usages of this word.

Firearms are divided by their caliber into *artillery* and *small arms*. The dividing line is not sharp, but generally 20 mm (0.79 in.) or 40 mm (1.58 in.). This book refers exclusively to small arms. These may be classified into *hand arms*, *shoulder arms*, and *machine guns*. These distinctions are not rigid but subject to some overlap, depending on the particular design of gun. *Hand arms* are those fired with one hand, such as *pistols* and *revolvers*. *Shoulder arms* are those which require the use of both hands to direct and operate, and are generally braced against the shoulder when

fired. This class includes *submachine guns*, *rifles*, and *shot-guns*. *Machine guns* are weapons which require a mount for firing and are served by a team rather than by a single gunner. *Automatic cannon* designates the largest sizes of machine guns.

The foregoing classifications were made on a basis of size and method of employment. Distinctions can also be made on the basis of the functioning cycle. Those which require manual operation by the gunner before and after each shot to actuate the firearm are known as *single-shot* or *magazine weapons*. Those in which a single pull of the trigger will fire only one shot, all other elements of the firing cycle being performed without action by the gunner, are termed *semiautomatic*. If a single pull of the trigger releases a continuous stream of projectiles, then the weapon is *automatic*. These last two terms have been subjected to some abuse as most "automatic" pistols are only *semiautomatic*.

1.2 AMMUNITION

In order to propel a missile from a firearm it is necessary to provide a series of expendable items with each shot. Collectively, these items are referred to as *ammunition*. Each *complete round of ammunition* includes a *projectile*, the *propellant*, a *primer* to set fire to the propellant, and a *cartridge case* to contain the propellant. In large artillery items where the complete round weighs over 100 lb these items are handled separately, but for the smaller calibers they are assembled together and called a *cartridge* (Fig. 1).

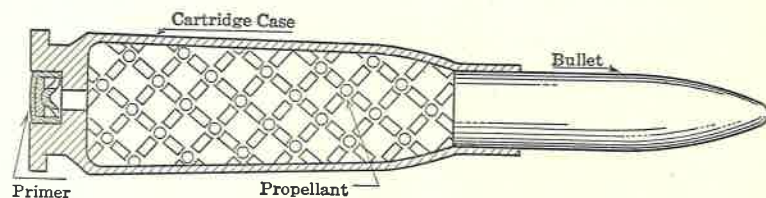

FIG. 1. Cartridge Components.

The *projectile* may also have various names, according to its design and structure. In artillery it is common to speak of *shell* and *shot*. In small arms the word *bullet* is used exclusively.

1.3 HISTORICAL

The first recorded use of firearms in western Europe is believed to relate to an attack on Seville in 1247.¹ At that time, loose powder and projectiles were in use, and it was necessary to ignite the propelling charge by touching it off with a burning match. Later, a mechanical arrangement was developed for lowering the match into the priming mixture when the trigger was pulled. This gun was called a *matchlock*. The use of flint in place of the smouldering match led to the use of the *wheel lock* and the *flintlock*, which were in turn superseded early in the nineteenth century by the *percussion gun*.

Up to that time, all weapons required separate loading of the bullet, propellant, and primer and were usually single-shot weapons. The invention of the *copper cartridge case* and the internal primer and the gradual development of gas-tight breech mechanisms made possible the production of automatic weapons.

At first these were multiple-barreled weapons, but they were soon succeeded by hopper-fed, crank-operated mechanical guns, of which the Gatling gun is perhaps the best known. This type of gun was perfected about 1865 and remained in use for forty years thereafter. Machine guns were first tactically employed as a form of artillery, and their general adoption was slow. However, the development of the *recoil-operated* machine gun by Maxim in 1884 produced the heavy machine gun in much the same form in which it exists today. This was shortly followed by the *gas-operated* guns of Brown-

¹ Greener, W. W., *The Gun and Its Development*, New York, Cassell, Petter, Galpin & Co., 1881.

ing. Military experience with these weapons accumulated rapidly during the various British conquests in Africa and in the Russo-Japanese War. In World War I, they were used with great effect on a scale never before anticipated.

Since that time, much effort has been expended in producing lighter guns in the small or rifle calibers. There are now available a large number of types of automatic pistols, light machine guns, submachine guns, machine pistols, automatic rifles, and heavy machine guns. Developments are continuing to produce automatic weapons in artillery calibers for aircraft and anti-aircraft purposes, as well as to secure increased performance from those types already in existence.

This book deals with modern types of ordnance, and although reference is sometimes made to early types in order to illustrate a fundamental feature, further reference to historical examples will not be made.

1.4 ENGINEERING UNITS

In this book the English system of units is used exclusively, as indicated by the following tabulation:

Mass, in slugs (lb-sec²/ft).

Length, in feet (ft) or inches (in.).

Force, in pounds (lb).

Time, in seconds (sec).

Temperature, in degrees Fahrenheit (deg F).

1.5 SYMBOLS AND ABBREVIATIONS

As far as possible the symbols and abbreviations recommended by the American Standards Association have been used. The following list presents those generally used in this book, together with the unit in which they are commonly expressed:

a Acceleration, linear, in feet per second per second (ft/sec²).

- d* Diameter or caliber, in inches (in.).
E Energy, in foot-pounds (ft-lb).
E Modulus of elasticity, in pounds per square inch (lb/sq in.).
e Strain (numeric).
F Load, in pounds (lb).
g Acceleration, gravitational, in feet per second per second (ft/sec²).
H Heat, in British Thermal Units (B).
h Heat transfer coefficient, in British Thermal Units per hour per square foot per degree Fahrenheit (B/hr-sq ft-deg).
k Spring constant, in pounds per inch (lb/in.).
k Thermal conductivity, in British Thermal Units per hour per degree Fahrenheit per foot (B/hr-deg-ft).
m Mass in slugs (lb-sec²/ft).
P Stress, in pounds per square inch (lb/sq in.).
p Pressure, in pounds per square inch (lb/sq in.).
r Radius, in inches (in.).
s Distance, in inches (in.).
T Period, time, in seconds (sec).
t Time, in seconds (sec).
u Expansion, in inches (in.).
v Velocity, in feet per second (ft/sec).
W Weight, in pounds (lb) or grains.
α Coefficient of expansion, linear, per degree Fahrenheit (per deg).

1.6 BIBLIOGRAPHIES

At the end of each chapter or appendix there is a brief bibliography of books and periodicals which have a general bearing on material discussed in that chapter. These lists have been limited to those works most easily available.

Numerous technical articles on ordnance appear in foreign military publications, and data are to be found in such

excellent German periodicals as the *Zeitschrift des Vereines Deutscher Ingenieure*, the *Zeitschrift für die Gesamte Schiess- und Sprengstoffwesen*, and the *Artilleristische Monatshefte*. A large technical literature also exists in book form in the German language.

In the English language, beside the books provided for the Military and Naval Academies, the most informative books have been published in England, those in America not generally being of a technical nature.

Occasionally articles which directly refer to ordnance design will be found in the technical journals published in the United States. More frequently, articles of a general engineering nature will be found which can be applied to gun problems after some study and conversion.

BIBLIOGRAPHY

- American Rifleman*, published monthly by the National Rifle Association, Washington, D. C.
- Army Ordnance*, published bimonthly by the Army Ordnance Association, Washington, D. C.
- GREENER, W. W., *The Gun and Its Development*, New York, Cassell, Petter, Galpin & Co., 1881.
- HAYES, T. J., *Elements of Ordnance*, New York, John Wiley & Sons, Inc., 1938.
- Naval Ordnance*, published by U. S. Naval Academy, Annapolis, 1939.
- WEISS, R., *Die Handfeuerwaffen (ihre Entwicklung und Technik)*, Leipzig, Teubner, 1912.

CHAPTER TWO

THE GUN BARREL

2.1 INTRODUCTION

This chapter treats of that element which is the center and basic element of all firearms—the gun tube or barrel itself. So fundamental is this item that the Germans and the French each call the gun bore by their word for “soul.” There is presented a brief outline of the processes which occur within the gun bore and of calculations which may be made regarding these phenomena. Of all the elements in the construction of an automatic gun, the barrel is the one least susceptible to exact mathematical treatment. The projection of the bullet is completed after a few thousandths of a second, within which period the internal temperature and pressure rise to a few thousand degrees Fahrenheit and about fifty thousand pounds per square inch, respectively, and die down again. In the face of these conditions, the gun designer can best rely upon past practice, keeping well in mind the limitations of such practice, and knowing that formulas indicate only the general nature of the situation.

2.2 INTERIOR BALLISTICS

Interior ballistics is the study of the physical processes which occur within the barrel of a firearm when it is discharged. These include burning of the propellant, the progress of the bullet, its velocity, the accompanying pressure, the transfer of heat to the walls of the tube, and the stresses set up in the metal tube. With so many variables involved, treatment of interior ballistics on a strictly mathe-

matical basis is very difficult and requires consideration of many details. Fortunately, the designer of a gun tube need not know the interior ballistic processes too accurately. This is permitted by a corresponding lack of accurate knowledge of the stresses induced in the bore during firing. As may be supposed, these stresses are due chiefly to the pressure produced by the powder gases and to changes in the physical structure of the metal due to increase in temperature. At the present time, little is known in detail of these thermal processes, which may be allowed for empirically. Indeed, the entire process of designing a barrel is based upon using the calculations as a guide and upon relying upon proof firings for the final checks.

Briefly, the calculations involved are of two sorts, (a) determination of pressure at various points along the bore and (b) determination of the minimum wall thickness required at each point.

The physicochemical process by which the propellant is ignited and transformed into a complex gas, together with the details of the transfer of energy from these gases to the bullet and the gun barrel, is well known and has been well described in other works on this subject. For the present purpose, an empirical procedure, sufficiently accurate, and agreeing with the assumed data, will be described. This is the method of LeDuc.

Assume that the length of barrel (more precisely the amount of bullet travel in the barrel) has been decided upon and that the maximum powder pressure and muzzle velocity have been determined. With these assumptions, LeDuc's method will permit the delineation of the curves relating the pressure and velocity to the instantaneous positions of the projectile in the barrel. Such curves are called pressure-travel and velocity-travel curves, respectively. The basis of LeDuc's method is the determination of a simple algebraic equation which will represent these relations with *sufficient*

accuracy. After some experimentation, LeDuc adopted the form

$$v = \frac{as}{b + s} \quad (\text{Eq. 1})$$

where v = velocity (ft/sec),

s = bullet travel (ft),

a = a constant (ft/sec),

b = a constant (ft).

Differentiation to obtain the equation for the pressure-travel relation gives

$$p = \frac{Wa^2bs}{gA(b + s)^3} \quad (\text{Eq. 2})$$

where W = projectile weight (lb),

g = gravity (ft/sec²),

A = bore cross-section area (in.²),

p = pressure (lb/in.²).

This formula can be manipulated to provide a formula for the maximum value p_m .

$$p_m = \frac{4Wa^2}{27gAb} \quad (\text{Eq. 3})$$

The development of these equations was empirical, yet they are sufficiently accurate for general purposes. For the reader who is interested in more exact (and more laborious) methods, the references at the end of this chapter are available.

LeDuc's equations as presented determine a projectile velocity curve and its corresponding pressure curve. No mention has yet been made of the pressure required to overcome the friction between the bullet and the bore or the pressure energy required to move the powder gases or to replace the energy transmitted to the barrel as heat. To cover these pressure losses, it is customary to allow 12 per cent. This 12 per cent difference was determined experimentally

many years ago and is now used as a general factor in all cases.

To use these equations, it is necessary to have values for a and b . The gun designer is more likely to know V , S , W , a and p_m , where V and S are the muzzle values of v and s , respectively. In this case, it is desirable to solve Equations 1 and 3 for a , giving

$$a = \frac{V(b + S)}{S} \quad (\text{Eq. 4})$$

$$a = \left(\frac{27gAbp_m}{4W} \right)^{1/2} \quad (\text{Eq. 5})$$

It may be shown that b is twice as great as the travel of the bullet to the point of maximum pressure. Hence, its value can be estimated. With this estimated value of b , a can be calculated by both Equations 4 and 5. This process should be repeated, using improved values of b until the same value is given for a by both equations.

While not required for the barrel design, the time required for the bullet to pass along the bore can also be deduced from LeDuc's equations. This is given as

$$t = \frac{b}{12a} \left(2.303 \log \frac{2s}{b} + \frac{s}{b} + 2.098 \right) \quad (\text{Eq. 6})$$

where t = time in seconds. When the muzzle value of S is used instead of an intermediate value s , t becomes t_1 , the *barrel time*. A more frequently used equation for the barrel time is

$$t_1 = \frac{3S}{2V} \quad (\text{Eq. 7})$$

This rule is based upon the assumption that the velocity-travel relation is a parabolic one and it finds usage because t_1 is such a small period of time that only one or two significant figures are retained.

2.3 STRENGTH COMPUTATIONS

It has already been noted that the application of the pressure to the gun tube lasts only for a brief fraction of a second. To represent the behavior of the barrel under these conditions, allowance would have to be made for the rapid application and equally rapid release of the pressure. Such equations would be entirely too complex to use, and hence, application is more commonly made of the formulas worked out by Lamé for thick cylinders *under steady pressure*.

In deducing these equations for the gun tube, it is assumed that there is no stress in the direction of the axis of the gun.

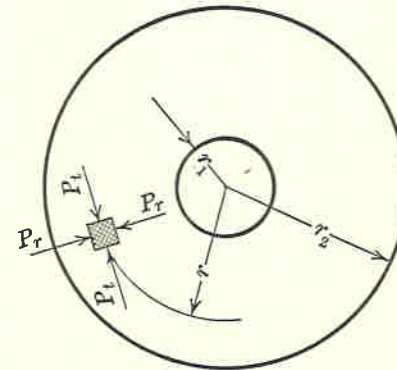

FIG. 2. Stress Definitions.

Further, it is assumed that the principal stresses lie in and normal to radial planes. Thus, there are concerned two sets of stresses, the *radial* and the *transverse*. When a compression is applied to the interior of the cylinder only, the stress distributions, as functions of the cylinder radius, will be as follows:

(a) Radial Stress

$$P_r = \frac{pr_1^2(r^2 - r_2^2)}{r^2(r_1^2 - r_2^2)} \quad (\text{Eq. 8})^1$$

¹ Equations 8 to 12 are reprinted by permission from *Applied Mechanics*, by C. E. Fuller and W. A. Johnston, published by John Wiley & Sons, Inc. The value of Poisson's ratio has been taken as 3.

(b) Tangential Stress

$$P_t = \frac{pr_1^2(r^2 + r_2^2)}{r^2(r_1^2 - r_2^2)} \quad (\text{Eq. 9})$$

(c) Radial Strain

$$e_r = \frac{pr_1^2(2r^2 - 4r_2^2)}{3Er^2(r_1^2 - r_2^2)} \quad (\text{Eq. 10})$$

(d) Tangential Strain

$$e_t = \frac{pr_1^2(2r^2 + 4r_2^2)}{3Er^2(r_1^2 - r_2^2)} \quad (\text{Eq. 11})$$

(e) Radial Expansion

$$u = \frac{pr_1^2(2r^2 + 4r_2^2)}{3Er(r_1^2 - r_2^2)} \quad (\text{Eq. 12})$$

where P_r = radial stress (lb/sq in.),
 P_t = tangential stress (lb/sq in.),
 e_r = radial strain (in./in.),
 e_t = tangential strain (in./in.),
 u = radial expansion (in.),
 p = bore pressure (lb/sq in.),
 r = any selected radial distance (in.),
 r_1 = bore radius (in.),
 r_2 = outside radius (in.),
 E = modulus of elasticity (lb/sq in.).

It is easily seen that P_t will always be larger than P_r . Further, P_t will always be in tension and P_r in compression, the largest value of either stress being at the inner (bore) radius. Hence, the largest stress will be the tangential stress at the bore. Placing r_1 in place of r in Equation 11, there is obtained

$$e_t = \frac{2p(r_1^2 + 2r_2^2)}{3E(r_1^2 - r_2^2)} \quad (\text{Eq. 13})$$

The general trends of the principal stresses are as shown in Figure 3. The numerical values shown there are computed for an internal pressure of 50,000 lb per sq in.

Further manipulation with these equations shows that increasing the outside diameter does not greatly increase the strength of the tube. In fact, a tube having a wall thickness equal to the bore diameter will be 84 per cent as strong as one infinitely thick, and the gain in strength with greater thickness will be very small. Hence, it is not common to make a gun tube more than three calibers in outside diameter.

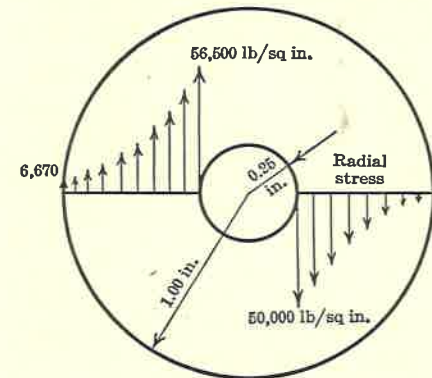

FIG. 3. Stress Distributions in Gun Tube.

In using the above formulas, care should be taken to use the proper value for the strength of the metal. This is usually taken at room temperature, but this choice of temperature should be noted, and correction made for any change in strength which occurs during heating.

2.4 VIBRATIONS

The previous section has given formulas for determination of the barrel diameter at various points along the bore. It will be found that the diameters so determined often appear ridiculously small when compared with those found in practice. In other words, strength is not always the governing characteristic. In some cases, heat capacity may limit the size, and in others, vibration of the barrel.

Barrel vibration, or *flip*, as it is sometimes called, is a

phenomenon produced when the projectile and the gases force their way through the barrel. While it is generally assumed that the movements of the barrel do not affect the accuracy of the gun because they do not occur before the projectile leaves the muzzle, such an assumption is not rigorously true. This is particularly so in the case of automatic weapons, where the vibrations caused by one round have not been damped out before the next round is fired. Unfortunately, formulas applicable to this problem are not easily available. In such cases, little is left the designer but to follow previous practice and to attempt to arrange his design symmetrically with respect to the axis of the bore so that there will be little eccentric metal to cause transverse vibrations.

2.5 RIFLING

Increased accuracy of projection is obtained if the projectile is spun about its longitudinal axis. This is accomplished by forming shallow, helical grooves along the bore. These grooves are termed the *rifling* of the gun, those portions of smaller diameter being called the *lands*, and those of greater diameter, the *grooves*. The length of bore required for one complete turn of the rifling is called the *twist*. The length of the twist is determined by the form of the bullet and its muzzle velocity. It is important that the twist be properly chosen, as too sharp a twist will overstabilize¹ the bullet and overstress the metal in the bullet jacket. On the other hand, too long a twist will cause the bullet to overturn in flight. It is customary to provide a twist of about one turn in thirty calibers, but this should be reduced for high velocities and short bullets. The best guide in the selection of twist, lacking a compendium of experimental data, is to follow previous practice for the particular bullet and velocity

¹ Stability and bullet spin are more fully covered in Appendix A to this book.

combination in question, or to conduct long-range firings, selecting that twist which gives the best accuracy.

The bullet is acted upon by a considerable force when spun by the rifling. This force may be estimated by determining the torque necessary to provide rotational acceleration for the bullet. Thus

$$\text{Torque} = \frac{Fd}{2} = \frac{2A\pi^2pd}{NW} \quad (\text{Eq. 14})$$

where F = rotating force (lb),

d = caliber (in.),

A = axial moment of inertia of bullet (grains-in.²),

p = powder pressure (lb/sq in.),

N = twist of rifling (calibers/turn),

W = bullet weight (grains).

The moment of inertia A of the bullet is

$$A = cWd^2 \quad (\text{Eq. 15})$$

where c is an experimental constant which corrects for the projectile not being of uniform density or cylindrical form. A value of $c = 0.11$ will serve for conventional projectiles. Hence, the force exerted by the rifling is

$$F = \frac{4cd^2\pi^2p}{N} \quad (\text{Eq. 16})$$

It is seen that this force varies with the powder pressure and will be greatest at the point of maximum pressure. This force is assumed to be exerted evenly along the bearing surface of the bullet and equally distributed among all the rifling lands.

The proper form of the rifling has been and still is a matter of great discussion. To attempt to list all the forms proposed would be an impossible task even if they could all be assembled. In the process of making guns in large quantities, the form of the rifling has been simplified and the number of

grooves has been reduced. Helical broaching and other new methods of manufacture have necessitated the use of rifling of a constant twist. While formerly rifling was very deep in order to allow powder fouling to accumulate in the grooves,

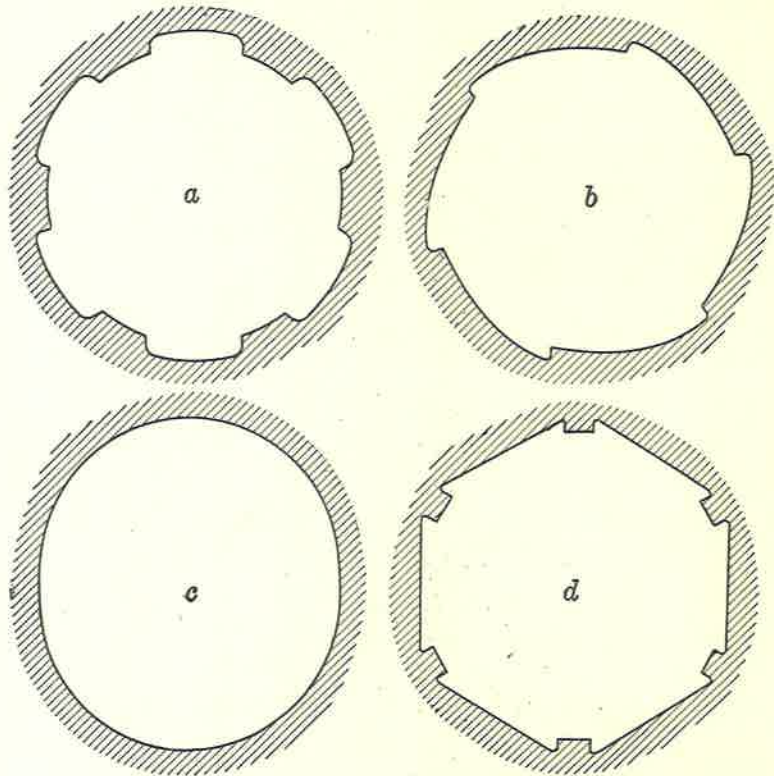

FIG. 4. Forms of Rifling.

the groove depth is now usually one per cent of the bore diameter, with a working tolerance of 0.002 in. on the diameter. Further, the form of the rifling is kept simple to facilitate tooling and gaging. The most commonly used form is that shown in Figure 4*a*, where the grooves are concentric with the lands. The grooves are commonly made wider than the lands on the basis that the compressive strength of the barrel steel is greater than that of the bullet jacket mate-

rial. It should be noted that this form requires that much of the bullet jacket be deformed sharply by the grooves. Hence, it is often suggested that so-called ratchet rifling be used (Fig. 4*b*), in which only the driving side of the land is made sharp. Further attempts (Figs. 4*c* and 4*d*) have been made to reduce this distortion to a minimum.

2·6 BARREL HEATING

Propulsion of the bullet is a thermodynamic process. Following ignition, the propellant burns to an incandescent gas at a temperature of about 3,500 F. The energy in these gases divides into the following parts:

- (a) Translational and rotational energy of the bullet.
- (b) Energy of motion of the gases.
- (c) Energy of the recoiling parts.
- (d) Energy used to overcome bullet friction in the bore, both jacket engraving and jacket friction.
- (e) Energy in the gases due to their heated state.
- (f) Energy transmitted from the gases to the gun barrel.

Approximately 30 per cent of the energy in the powder charge appears as heat in the barrel. This heat is not uniformly distributed along the barrel, but is slightly greater at the breech end, as is to be expected because of the higher temperatures and longer times of exposure at that end. There is practically no transfer of heat to the chamber because most of the heat received at that point remains in the cartridge case and is removed when the case is extracted.

The problem of removing heat from a gun barrel has received much attention, but up to the present time no method has been devised which will remove the heat as fast as it is absorbed from a modern weapon firing at its cyclic rate. The primary effect of this lack of heat balance is an increase in the bore diameter. When the temperature of the barrel is

uniform from bore to outside, the increase in diameter may be computed by the formula:

$$d' = d(1 + \alpha\Delta t) \quad (\text{Eq. 17})$$

where d' = diameter at temperature considered (in.),
 d = diameter before temperature change (in.),
 α = linear coefficient of thermal expansion (per deg),
 Δt = temperature change (deg).

The value of α for steel may be taken as 6.5×10^{-6} per degree Fahrenheit.

At the breech this expansion causes the bullet to pass part way down the bore without spinning. When it does strike the rifling, it is moving too fast to follow the twist and the jacket may be stripped. At the muzzle, expansion permits the bullet to wobble (or yaw) at that point with corresponding inaccuracy in flight. Three basic methods are available for attempting a heat balance:

- (a) Radiation and convection to the ambient air.
- (b) Conduction and convection to a surrounding fluid jacket.
- (c) Removal of the barrel from the gun for a cooling period, during which the gun may continue firing by the use of another barrel.

Transfer of the heat through the gun tube may be represented by Equation 18, which expresses the temperature difference between the inner and outer surfaces required to maintain continuous heat flow through the metal.

$$\Delta t = \frac{1.151 \log (d_2/d_1)}{\pi k} \quad (\text{Eq. 18})$$

where Δt = temperature difference (deg),
 d_2 = outside diameter (in.),
 d_1 = bore diameter (in.),
 k = thermal conductivity (B/hr-deg-ft).

A representative value of k for steel is 9 B/hr-deg-ft. More exact values can be obtained from physical tables.

Heat transfer from the barrel to the surrounding air is accomplished by radiation and convection. This exchange is dependent upon the exposed surface of the barrel, the temperature difference between the barrel and the air, and an

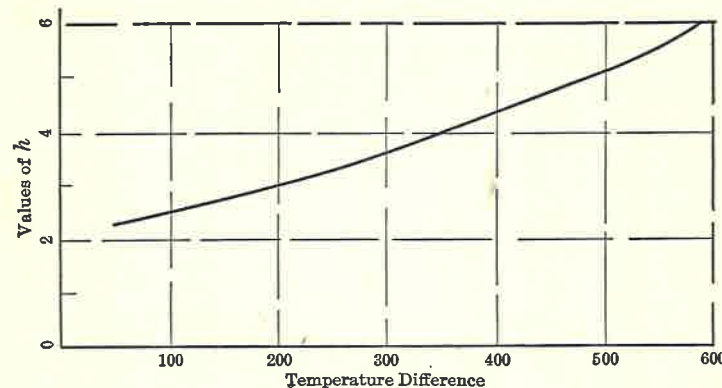

FIG. 5. Radiation and Convection from a Gun Barrel.

empirical factor. The heat transferred in still air can be represented by

$$q = hA\Delta t \quad (\text{Eq. 19})$$

where q = rate of heat transfer (B/hr),
 h = an empirical factor (see Fig. 5),¹
 A = surface area of barrel (sq ft),
 Δt = temperature difference (deg).

When the barrel is enclosed in a water jacket, the conditions are somewhat different, as the heat is removed by conduction and convection. It may safely be assumed that the water is boiling, as very few rounds are required to reach this

¹ The values of h in Figure 5 are reprinted by permission from *Elements of Heat Transfer*, by M. Jakob and G. A. Hawkins, published by John Wiley & Sons, Inc., and specifically refer to a tube having an outer diameter of 1.3 in. However, these values are within 10 per cent of those for diameters encountered in small arms barrels.

state. The erroneous assumption is generally made that the exterior of the barrel does not reach a temperature higher than the boiling point of water. This cannot be true, as the temperature of the barrel must be higher than the boiling point in order that heat may flow into the water and raise it to its boiling point. The amount of heat transferred into the water is dependent upon this temperature difference; at a temperature difference of 45 degrees Fahrenheit the rate of heat transfer reaches its maximum value of 400,000 B/hr-sq ft.¹ Further increase in the barrel temperature will actually result in a decreased rate of heat flow.

2.7 TAPERED BORE BARRELS

Much attention has been given to the use of tapered or constricted barrels for the purpose of obtaining high velocities. The logic behind this proposal may be easily explained. The air resistance opposing a projectile in flight is proportional to the square of its caliber. The force with which it is propelled through the gun bore is likewise proportional to the square of the caliber. Hence, it appears that there would be greater ballistic efficiency if the bullet could be of large caliber while in the bore yet small after leaving it. The development of these principles is principally due to the work of Puff and the better-known experiments of Gerlich.

In Gerlich's rifles, the bore was not of uniform diameter throughout, but contained three zones. The breech zone was of uniform diameter; in the middle zone both the lands and grooves tapered, while in the muzzle zone the lands and grooves were both of uniform diameter. By the use of this construction and a properly designed powder, velocities in the neighborhood of 5,000 ft/sec were obtained with a shoulder rifle. The acute student will note that work cannot be obtained without a corresponding consumption of energy. In

¹ Reprinted by permission from *Heat Transmission*, by W. H. McAdams, 2nd ed., p. 297, published by McGraw-Hill Book Co., Inc., 1942.

this case, the bullet must necessarily be deformed as it passes through the barrel. This requires the expenditure of energy in addition to the energy required to overcome the normal bore friction of a non-tapered barrel. As a result of many experiments, it is reasonably established that, *compared on a basis of muzzle caliber*, the tapered bore will not in itself afford the means of attaining higher velocities. The advantage accruing by reason of the initial large bore diameter is cancelled by the work required to deform the bullet as it passes through the constriction.

Further, satisfactory accuracy is not usually obtained with weapons of this type. The problem of deforming the bullet in such a manner that it remains uniform and symmetrical has not been completely solved. In comparing the performance of a tapered bore gun with a conventional one, many factors such as forcing resistance, powder characteristics, and bullet performance are involved. To sum up, the tapered gun requires all the impedimenta and disadvantages of its larger caliber and gives only the conveniences and performance of its smaller. An equal quantity of powder in a conventional gun may be made to produce equal performance.

BIBLIOGRAPHY

- JAKOB, MAX, and HAWKINS, G. A., *Elements of Heat Transfer*, New York, John Wiley & Sons, Inc., 1942.
- McADAMS, W. H., *Heat Transmission*, New York, McGraw-Hill Book Co., Inc., 1942.
- MACRAE, A. E., *Overstrain of Metals*, London, H. M. Stationery Office, 1930.
- MARTIN, A. E., and MUIR, J., "Vibrations of a Rifle Barrel," *J. Roy. Tech. College. (Glasgow)*, Vol. 4, p. 42, 1938.
- ROBINSON, C. S., *Thermodynamics of Firearms*, New York, McGraw-Hill Book Co., Inc., 1943.
- SEELY, F. B., *Advanced Mechanics of Materials*, New York, John Wiley & Sons, Inc., 1932.
- TIMOSHENKO, S., *Strength of Materials*, New York, D. Van Nostrand & Co., 1941.

CHAPTER THREE

RECOIL

3.1 INTRODUCTION

The previous chapter described how the propellant charge affects the gun barrel in detail. The purpose of this chapter is to describe motion imparted to the gun barrel as a whole. Recoil is produced by two separate causes:

- (a) Recoil due to the reaction caused by the forward motion of the projectile.
- (b) Recoil due to the reaction of the expanding powder gases after the bullet has emerged.

In this chapter, a distinction will be made between recoil, or motion of the gun in a direction parallel to the bore; jump, or motion of the gun about its support; and flip, or motion caused by vibrations of the barrel.

When the recoil is unopposed by an external force the motion is said to be *free recoil*, whereas if it is opposed by some form of brake it is known as *retarded recoil*.

Regardless of what system is utilized to motivate the action of an automatic gun, recoil is always present and must either be utilized or controlled. Of particular significance is the energy in the recoiling parts, for this constitutes (in a recoil-operated gun) the source of energy for functioning the mechanism, as the recoil energy causes the gun to move relative to its mount.

3.2 FREE RECOIL DUE TO BULLET MOTION

The motion of a gun in free recoil, during the period when the bullet is in the bore, may be easily computed from New-

ton's statement that "action and reaction are equal, opposite, and instantaneous." In Figure 6, the solid lines show the position of a gun barrel and projectile before firing, whereas the dotted lines show their positions at any subsequent moment t . If the weight of the projectile is W and

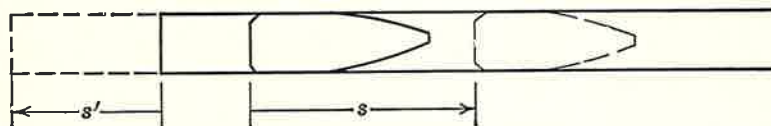

FIG. 6. Recoiling Gun Barrel.

that of the barrel is B , then the powder force acting equally upon both is

$$F = Ba_B = Wa_w \quad (\text{Eq. 20})$$

where F = force exerted by the gases,

B = recoiling weight,

W = projectile weight,

a_B = acceleration of the recoiling weight,

a_w = acceleration of the projectile.

This equation can be reduced to

$$Bs' = Ws \quad (\text{Eq. 21})$$

where s' = travel of the recoiling parts,

s = travel of the projectile.

If the interior ballistic trajectory of the gun is known, s is known in terms of time, and s' may be obtained from it by simple proportion. A slight error is introduced, however, because the origin from which s is measured itself recoils; hence, $W(s - s') = Bs'$ is a more rigorous equation, as s is the motion of the projectile relative to the barrel. Then

$$Ws - Ws' = Bs' \quad \text{and} \quad s' = \frac{Ws}{B + W} \quad (\text{Eq. 22})$$

If desired, a still more rigorous solution may be obtained by taking account of the powder gases. By adding half the

charge weight (c) to both the projectile and the gun, this equation becomes

$$s' = \frac{(W + c/2)s}{B + W + c/2} \quad (\text{Eq. 23})$$

Similarly, the velocity of the gun at any instant may be found from

$$v_B = \frac{(W + c/2)v_W}{B + W + c/2} \quad (\text{Eq. 24})$$

3.3 FREE RECOIL DUE TO GAS MOTION

The foregoing relations hold only while the projectile is in the bore. After it emerges, the recoiling system consists only of the barrel and the powder charge. The active force is the reaction of the gases as they expand from the muzzle pressure to that of the atmosphere. It is known that the average velocity of the powder gases is in the neighborhood of 4,700 ft/sec. Placing this value in the momentum equation, there is obtained for the maximum velocity of free recoil

$$v_B = \frac{Wv_0 + 4,700c}{B} \quad (\text{Eq. 25})$$

Vallier has shown that the time required for the gases to expand may be approximated by

$$t' = \frac{c}{gAp_1} (9,400 - v_0) \quad (\text{Eq. 26})$$

where t' = gas expansion time (sec),

c = charge weight (lb),

A = bore area (sq in.),

p_1 = muzzle pressure (lb/sq in.),

v_0 = muzzle velocity of the projectile (ft/sec).

The additional distance recoiled during this time interval will be

$$\frac{W + c/2}{B} v_0 t' + \frac{2Ap_1(t')^2}{3B} \quad (\text{Eq. 27})$$

After the end of this period ($t_1 + t'$) the gun will not be at rest but will continue to recoil at the maximum velocity v_B until brought to rest by some outside force. In practice, such a force (usually friction) does exist, acting at all instants after the motion of the projectile starts.

3.4 RETARDED RECOIL

The distance over which a gun barrel recoils up to the time the gases cease to act is very small, and much of this distance may be utilized in overcoming free play in the mount or in building up inertia forces. Hence, the actual improvement to be gained in using a correction for resistance to recoil during this period may often be doubted. If a constant resistance K is assumed, the decrease in velocity after any time t will be gKt/B , and the decrease in distance will be $gKt^2/2B$. It is assumed that the line of action of force acting on the recoiling mass is in the axis of the bore. Only under such a condition can the straight-line recoil described be maintained. Unfortunately, this condition is realized in only a very few actual cases, practical design conditions requiring that the barrel fastenings be above or below the axis. This causes the barrel to turn about its support, throwing the muzzle in a direction away from the mounting. As this motion occurs before the bullet has left the muzzle, it is projected in a direction different from that in which the barrel was pointed before firing, and it possesses a lateral velocity component due to the tangential velocity of the gun muzzle. The combined effect, known as *jump*, must be taken into consideration when computing sights or preparing firing tables.

3.5 RECOIL BRAKES

There are in general two means of obtaining the resistance to recoil referred to in the preceding section. These are *muzzle brakes* and *fluid* or *spring brakes*.

Muzzle brakes are operated by the impulse from the gases leaving the muzzle of the gun. Obviously then, a muzzle brake can have no effect until after the bullet has left the barrel and recoil has begun. As shown in Figure 7, a muzzle brake is essentially a device for reversing the motion of the escaping gases. Because a clear path must be left for the passage of the bullets, a considerable portion of the gases will take the direct path of escape as represented by Arrow

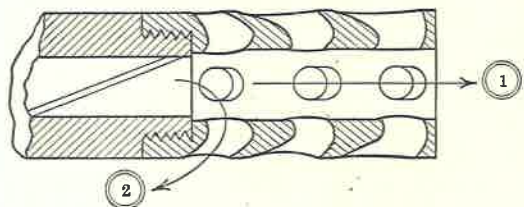

FIG. 7. Muzzle Brake.

1. However, the pressure of the gases will cause the stream to diverge so that some will enter the lateral passages and be diverted as shown by Arrow 2.

The maximum impulse or momentum change which could be obtained from a muzzle brake is twice the momentum of all the gases. If the initial gases discharged are moving with a velocity v and the last have practically no velocity, then their average velocity of escape will be $v/2$ and their momentum $cv/2g$, where c is the weight of the powder charge. If the gases are discharged in a direction parallel to the bore but directed to the breech, an impulse equal to cv/g will be obtained. However, owing to the practical undesirability of such complete reversal as well as to various losses, brake efficiency is usually rather low.

When constructed with exit orifices entirely around the circumference of the brake, there will be no effects in any direction other than that of the axis of the bore. Sometimes the ports are limited to two opposite faces to control the gas blast. For example, the ports can be placed on the sides so

that no gases will be directed downward and disclose the gun position to the enemy by kicking up dust in front of the muzzle. If diametrically opposite ports are not provided, the brake will have directional properties. Such attachments are sometimes called *stabilizers* or *compensators*. If a weapon tends to climb or turn in some direction because of unsymmetrical mechanism or mounting, such a compensator can be used to restrain the motion. The opening, of course, must point in the direction toward which the muzzle moves without the stabilizer.

It is often desirable to control the motion of the barrel after the action of the gases has ceased. If the barrel energy is to be restored to the system at a later time in the cycle, springs can be used. Helical springs are most commonly used, although spiral or "clock springs" can also be used. Helical springs are useful because of their low hysteresis. Care must, however, be taken in the use of long springs to prevent the occurrence of spring surges. With the high rates of fire now in use, and consequent rapid motion of parts, the natural rate of the spring used must be high enough to permit the spring to follow the moving member with full force.

Where higher compression rates are required over a limited distance, Belleville springs will permit greater economy of space than helical springs.

Mechanical springs have linear characteristics and their force patterns cannot be varied. The use of *hydraulic* brakes permits the resistance along the motion to be varied according to the desire of the designer. A hydraulic brake consists essentially of a piston moving through a closed chamber filled with fluid. The friction and inertia of the fluid in passing from one side of the piston to the other constitute the brake reaction. Such energy is dissipated as heat and cannot be returned to the system.

To vary the brake resistance, it is necessary to regulate the passage of the fluid past the piston. This can be done by

placing orifices in the piston or by providing passages around it in the wall of the chamber. Figure 8 shows a brake having a slot in the upper part of the piston. This slot rides

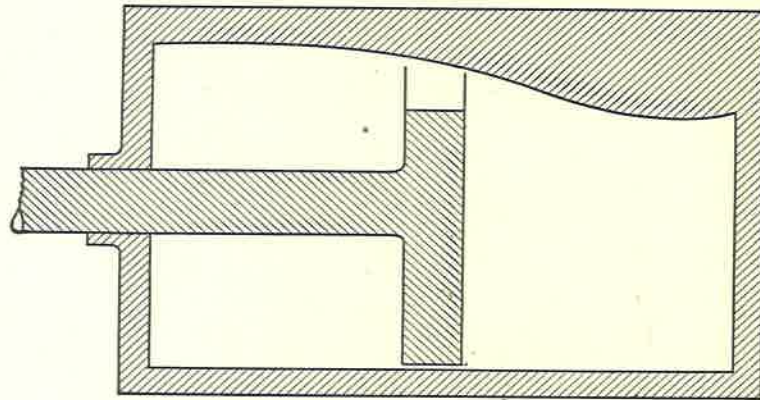

FIG. 8. Hydraulic Brake.

over a tongue which is curved in profile to produce the desired orifice at each point of piston travel.

BIBLIOGRAPHY

- RAUSENBERGER, F. (Translated by A. Slater), *Theory of the Recoil of Guns*, London, Crosby, Lockwood & Son, 1909. (The 1939 edition published by Springer in Leipzig is much improved, but it has not been translated from the German.)
- RAVELLI, E., "Étude sur la Théorie du Frein de Bouche," *Mem. artillerie française*, Vol. 9, p. 465, 1930.

CHAPTER FOUR

AUTOMATIC WEAPONS—FUNCTIONS

4.1 INTRODUCTION

Those functions which must be performed in the operation of any firearm are set forth in this chapter. In the operation of a single-shot weapon these actions are performed by the muscles of the firer; in an automatic weapon, by the energy released by the combustion of the propellant. In a semi-automatic weapon there is a division of labor—some of the functions are manual, and the others are performed by the gun. Usually a semiautomatic weapon performs all the operations except firing, as in the misnamed *automatic* pistol. To quote an example from artillery practice, most anti-aircraft guns are semiautomatic in that they perform all functions except feeding and firing. Semiautomatic firing can be described as a special case of automatic firing, in which the complete cycle is normally interrupted before completion.

The functions necessary to the complete cyclic operation of a firearm are:

- | | |
|---------------------------|-----------------|
| (a) Feeding. | (d) Extracting. |
| (b) Obturating (locking). | (e) Ejecting. |
| (c) Firing. | (f) Cocking. |

4.2 FEEDING

Feeding is the action of placing the cartridge into the chamber of the weapon. In its simplest form, it consists in pushing a cartridge from the mouth of a magazine directly into the chamber, nearly all the motion of the cartridge being in prolongation of the bore. (See Fig. 9.) Slightly

more complication is encountered if the mouth of the magazine is not approximately in line with the bore and the cartridge must be fed by another path. This condition is encountered in magazine rifles, where a lifting mechanism is

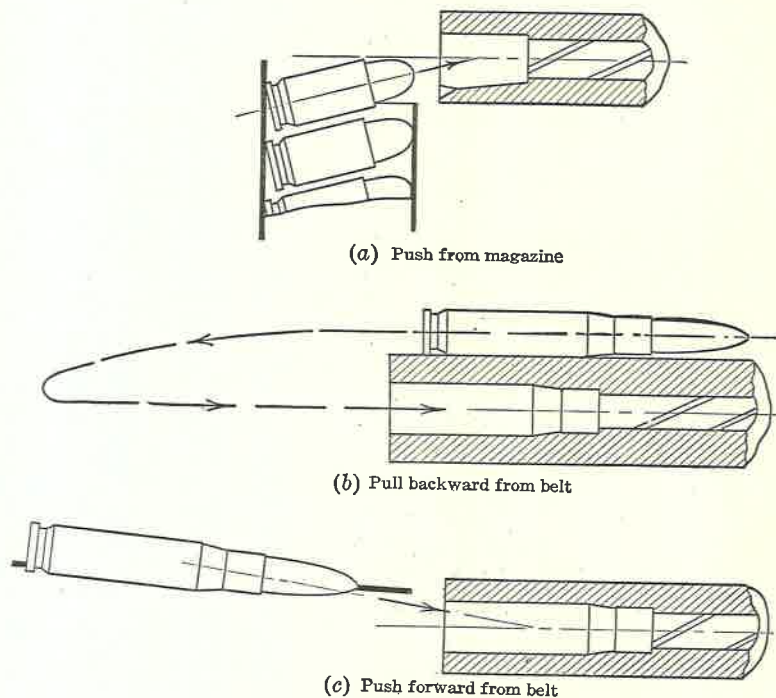

FIG. 9. Methods of Feeding.

employed. A much greater demand is placed upon the feeding device if the cartridge must be withdrawn rearward from a link or belt and then transferred to the bore axis and subsequently fed forward. This action is encountered in machine guns such as the Browning and Maxim types. In addition to the movement of the entering cartridge, a belt-fed weapon is also required to advance the belt one step for each round. In a magazine weapon, this power is supplied by the magazine spring. Feeding mechanisms can be simplified if the cartridge can be pushed directly forward from

the link into the chamber. This type of action, with the exception of advancing the belt, approaches the construction of a magazine fed gun, a type which has been developed to a highly successful state by the Germans in many of their machine guns.

4.3 OBTURATING

Locking, or obturating, consists in securing the propellant in the gun so that its gases cannot escape to the firer, but can expand only by propelling the bullet toward the muzzle. The actual sealing of the gases is well taken care of by the use of a brass (or steel) cartridge case. However, if the case is not properly restrained, it will be blown out of the chamber entirely or ruptured into two or more pieces. To support the case, there is provided a strong and bulky member, known as the bolt or breech. This breech closure is locked to the barrel by any of several means. In low-pressure weapons, such as submachine guns, it is necessary to hold the breech only by a spring. For guns of higher power, the bolt can be locked by interrupted threads, which engage by a fraction of a turn. It is possible to have the bolt tip up, or to have it hinged so that a portion tips against the locking abutment, or to have the bolt remain stationary while a separate member, known as the breech lock, moves laterally to engage both the barrel and breech members. Several of these types are illustrated by Figure 10. In some cases, the entire breech moves laterally, but this type is usually confined to cannon and is used on several semiautomatic anti-aircraft guns.

4.4 FIRING

The entire train of actions which occur from the instant the igniting train or trigger is released until the cartridge is ignited is designated *firing*. This mechanism is so important that Chapter 7 is devoted to consideration of firing mechanisms alone. In single shot and semiautomatic weapons, firing

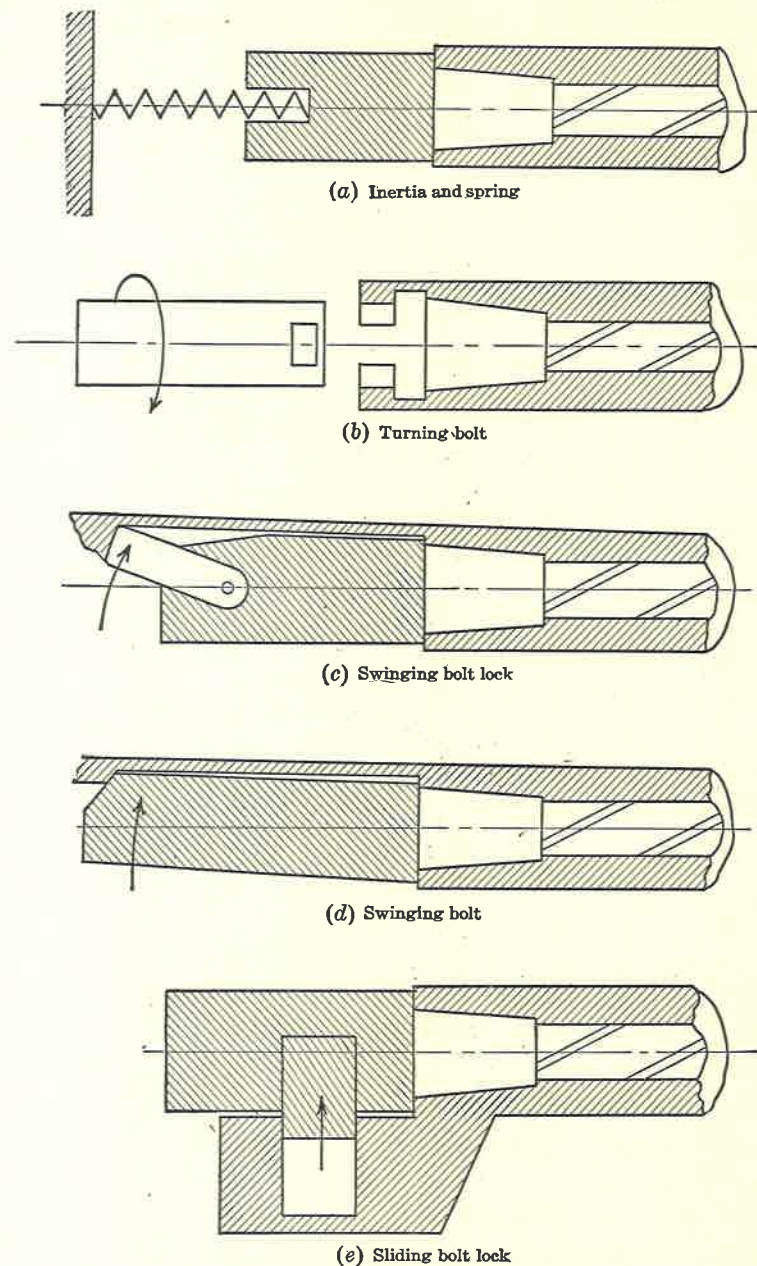

FIG. 10. Types of Locks.

is initiated by the pressure of the gunner's finger upon a trigger. In automatic fire, the first round is so fired, the firing of subsequent rounds being performed repeatedly by the mechanism when it again reaches the firing position. In this

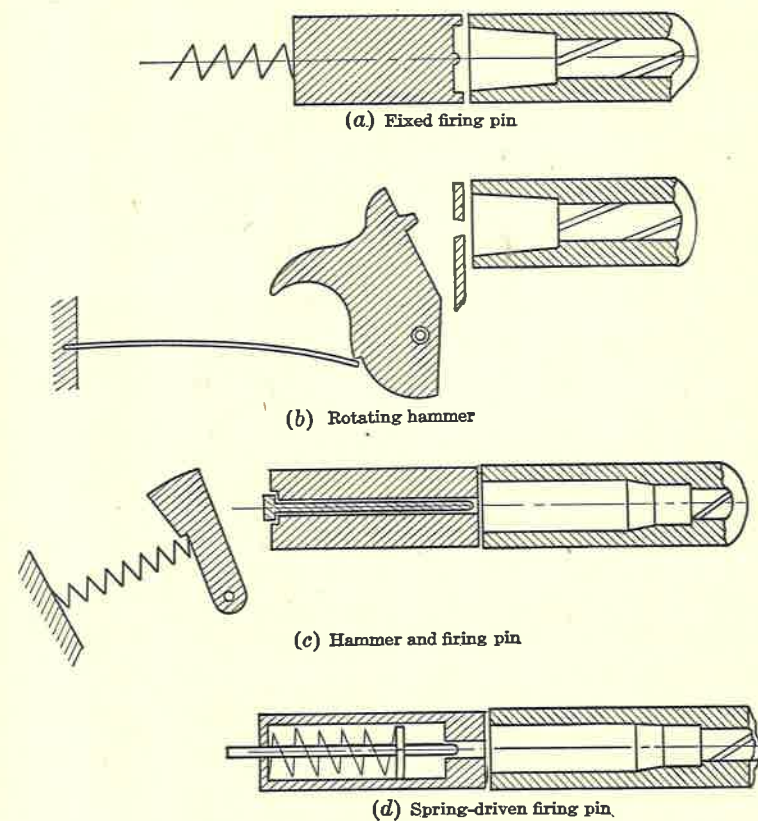

FIG. 11. Firing Arrangements.

case, the trigger usually acts as the gun control, and the gun will stop firing when the trigger is released.

While retaining the study of firing trains for a later chapter, it will be noted here that the ignition of the cartridge is caused by the delivery of a sharp blow upon the primer. The member which delivers this blow will be one of the four forms shown in Figure 11.

The first form appears where the firing pin is a part of the bolt or closure. This is called a *fixed firing pin*. While this type gives maximum simplicity in construction, it presents the defect that the firing pin is always exposed and liable to ignite a cartridge that has not been fully chambered. The fixed firing pin is commonly used for submachine guns, where extreme simplicity is desired.

The second form consists of a rotating member called a *hammer*, which, when rotated by a spring, thrusts a pointed corner against the primer. This type provides a control separate from the closing of the bolt, but because of the rotation necessary, is limited to revolvers, as only a thin breech plate can be provided. Such construction is of sufficient strength only where low gas pressures are employed.

The hammer can be separated by a considerable distance from the primer and connected to it by a long, slender *firing pin*. By this means more metal and consequent greater strength are provided in the breech block. The firing pin may be provided with its own spring, or even actuated by a slide or other moving member of the gun without the assistance of a rotating hammer.

Because of these diverse firing mechanism arrangements, there will be found a great variety of trigger and sear mechanisms. This occurs because the release of the energy for the ignition of the primer can be transmitted to the primer through so many possible paths, dependent upon the type of firing mechanism used, the type of fire control desired, and the space limitations of the gun.

4.5 EXTRACTING

This is the act of withdrawing the fired case from the chamber of the barrel. Immediately after firing, the thin case is pressed tightly into the barrel, and a considerable force is needed to loosen it. This effort can be reduced in two ways: either the case may be extracted before the powder

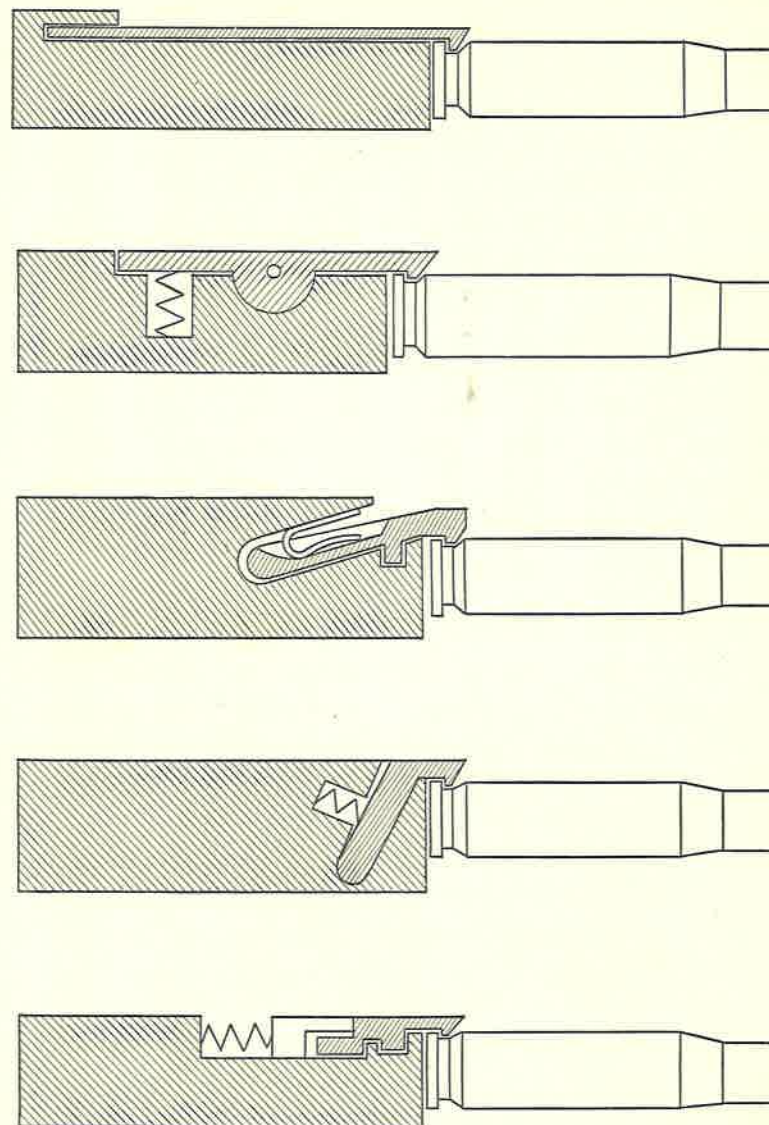

FIG. 12. Types of Extractors.

gases have all left the barrel, so that they aid in blowing the case out, or a relatively large time may be allowed to elapse so that the hot case may cool and release itself. In any event, it is helpful to so arrange the mechanism that a leverage is provided for the initial extraction. In rotating-bolt mechanisms, this leverage is provided by the slow lead of the locking threads. In others, it may be provided by the linkage of the operating system. The extractor itself usually follows a very set pattern, as it is strictly limited by the design of the cartridge case. This may be of two types: (a) rimmed or (b) rimless. In either form there is provided a shoulder at the head of the case in which a hook can catch and withdraw it. This hook, the extractor, is snapped over the case by a spring, the strength of which is sufficient to hold the case against the breech until it is ejected from the gun. Figure 12 depicts several different types of extractors.

4.6 EJECTING

The act of clearing the spent case from the gun mechanism is ejection. It is a later part of the extraction operation, but deserves separate study, as extraction and ejection are nearly always performed by different parts of the gun mechanism. In the U. S. rifle, cal. .30, M1, the ejector is in the face of the bolt and is always exerting pressure upon the head of the case. (See Fig. 13.) The cartridge case, however, is held in line by the constraint of the chamber. When this constraint is removed by the case being withdrawn from the chamber, the case is thrown out of the gun. As the breech and case are in motion during extraction, the ejector can occupy a relatively fixed position in the receiver. In fact, it can be permanently fixed in the receiver and can operate by striking the case an eccentric blow as the latter is drawn past it by the extractor. In the Mauser type of rifle the ejector has only slight motion. However, in the Japanese Model 99 light machine gun, the ejector is a long curved lever. As the rear

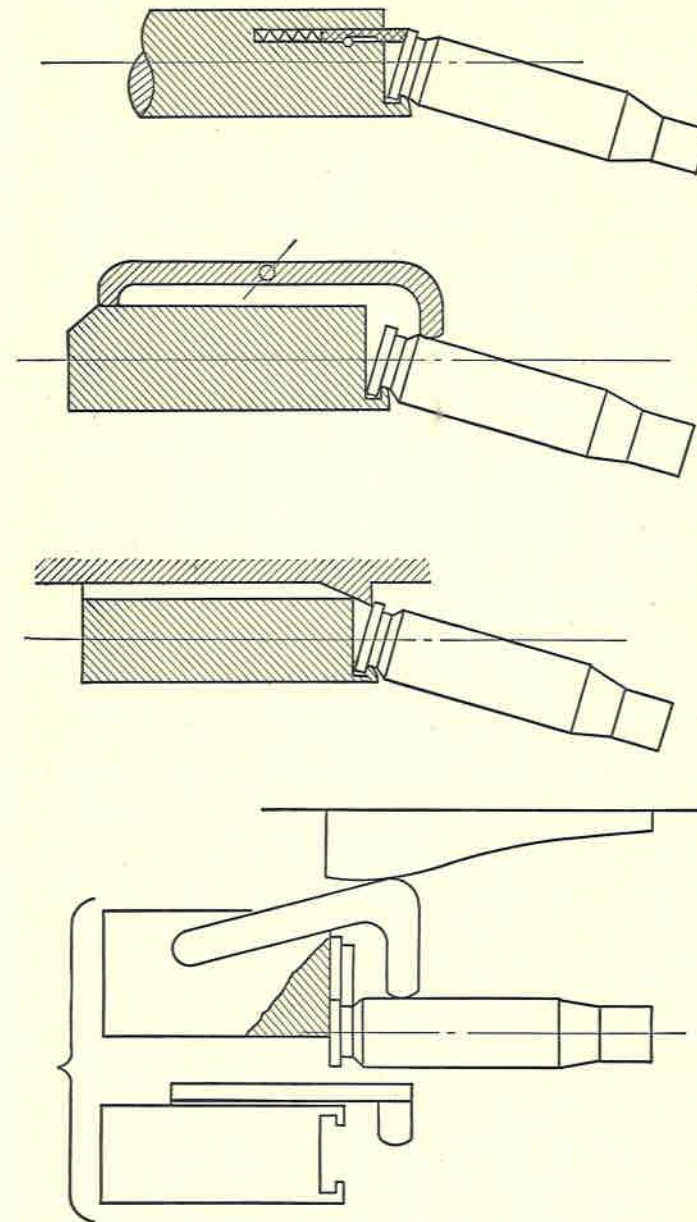

FIG. 13. Types of Ejectors.

of this lever is struck by the rear of the recoiling bolt, the front end is swung around to strike the cartridge case transversely and drive it out of the receiver.

4.7 COCKING

The action of preparing the firing mechanism for the next firing is called cocking. After igniting a cartridge, this part of the gun mechanism is itself discharged, or uncocked, and must be returned to a charged, or cocked, state. If the firing pin is not spring loaded, this is usually accomplished by a *slight* rearward motion of the parts. If there is a spring, however, it usually requires almost a full stroke of the mechanism to carry the firing pin back against its spring and to catch it upon a detent, where it is held until released. This detent is called the *sear*.

With the completion of these six functions, the usual cycle of automatic gun action is completed. It will always be found that all these functions exist in every gun, although the mechanism may be so arranged that multiple operations are performed by a single part so that some operations may on original inspection appear to have been omitted or neglected.

CHAPTER FIVE

AUTOMATIC WEAPONS—SYSTEMS

5.1 INTRODUCTION

In final analysis, all automatic guns derive their motive power from the release of one or more stressed springs. The gun becomes automatic because some means is present after firing a cartridge to divert some energy into the spring and to recharge it. Concurrent with this recharging, the various functions described in the preceding chapter are performed. This chapter describes in a general way the means used to transmit energy from the fired charge to the mechanism of the gun. The study of complete gun designs, showing how the other functions are performed, is reserved for Chapter 6.

Gun operating systems are usually classified according to the manner in which the power is transmitted. This may be by blowing back the breechblock directly, by utilizing the recoil of the gun, or by leading off a small portion of the powder gases. These may be further subdivided as follows:

- (a) Inertia—direct blowback.
- (b) Delayed inertia—blowback member retarded by an auxiliary device.
- (c) Short recoil—barrel recoils approximately two or three calibers.
- (d) Long recoil—barrel recoils approximately ten calibers.
- (e) Gas.

Each of these methods is described in a separate section. These examples are not given in detail, nor are all common

combinations shown. The elements given are, in practice, combined as desired to operate with the particular cartridge in question.

The paragraphs of this chapter describe only those parts of the mechanisms necessary to the locking or opening of the guns. Little or no mention is made at this time of the other parts required to perform the other automatic functions.

5.2 INERTIA

The *inertia* type of gun action is sometimes called “blow-back” because there is no positive breech lock and the pressure of the powder gases in the chamber blows the bolt back. This type of mechanism is usually used for pistols and submachine guns where the pressure is light and the obturation problem not too severe. If higher loads are to be handled, it is preferable to use a locked action, or at least to provide some sort of delaying action to reduce the motion of the bolt. This latter type is called *delayed blowback* action. Examples of inertia actions are almost too common to mention; the Thompson submachine gun, the U. S. submachine gun M3, the Italian Villar Perosa, and the German Solothurn and Bergmann submachine guns being familiar weapons of this type. The principal components of an inertia gun are shown in Figure 14. They consist of the *barrel*, the

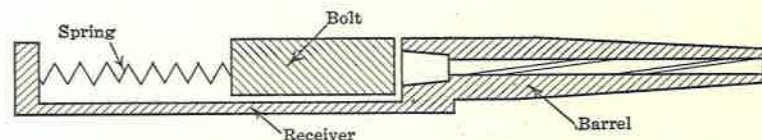

FIG. 14. Elementary Inertia Action.

breech closure or *bolt*, the *receiver*, and the *driving spring*. When the cartridge is fired (by some means not shown in the sketch), the powder gases drive the bullet forward and impart to it a muzzle momentum, as already described. It has been shown that these gases also impart a momentum to the

gun in the opposite direction. The barrel and receiver can be conceived of as fixed or nearly so because their weight is much greater than that of the bolt, so that practically the entire recoil effect of the gases appears as motion of the bolt. Motion of the bolt will be resisted by:

- (a) The driving spring—this spring must permit the bolt to recoil sufficiently to feed a new cartridge from the magazine.
- (b) The inertia of the bolt—the larger this mass, the slower it will recoil.
- (c) The extraction effort of the case.
- (d) Friction between the bolt and the receiver.

If the impulse of the gases is assumed to be transmitted in an infinitesimal time, the initial recoil momentum of the bolt will be

$$v_B B = \left(W + \frac{c}{2} \right) v_W \quad (\text{Eq. 28})$$

From this value of the bolt velocity (v_B) the initial bolt energy can be computed as

$$E = \frac{B v_B^2}{2} \quad (\text{Eq. 29})$$

As the breech recoils and the spring is compressed, the bolt velocity decreases, but no energy will be lost (neglecting items *c* and *d*); instead, it will be transferred to the spring. Hence, the kinetic energy of the bolt and the potential energy in the spring will at all instants have a constant sum.

The energy of the spring at any point of the bolt travel is known if the spring compression rate is known. If the spring force at point s is $F = F_0 + ks$, the energy received from the bolt after a motion s is $F_0 s + ks^2/2$. The energy remaining in the bolt then is

$$\dot{E}_R = \frac{B v_B^2}{2} - \frac{ks^2}{2} - F_0 s \quad (\text{Eq. 30})$$

and the velocity of the bolt may be determined for that position.

The time required for the bolt to recoil may be shown to be

$$T = \frac{v_B B}{3} \left(\frac{1}{F_0} + \frac{2}{F_0 + ks} \right) \quad (\text{Eq. 31})$$

If the breech rebounds from the backplate without loss of energy, the time for a complete cycle will be $2T$, and the rate of fire will be

$$N = \frac{30}{T} \quad (\text{Eq. 32})$$

where N is the rate of fire in rounds per minute and T is the time for one stroke of the bolt.

5.3 DELAYED INERTIA

The *delayed inertia* type of action, more usually called the delayed blowback, is distinguished from the simple inertia type of mechanism in that the opening of the breech closure is retarded so that the breech does not move relative to the barrel as soon as gas pressure is applied to it. These two types of action are similar in that there is no mechanical element directly blocking the bolt, only a very high mechanical disadvantage. This definition must be accepted with some reserve. The line of demarcation between delayed inertia and short recoil may sometimes be imperceptible, the final criterion being whether the breech closure is opened by residual gas pressure or by the action of a rigid member of the gun.

The delay may be produced by several means. They are generally based upon the provision of a mass of metal which must be moved at a great mechanical disadvantage for the initial portion of the cycle.

In the Schwarzlose machine gun this delay is provided by two rotating links. It is necessary to put kinetic energy into these members in order to start the retraction of the bolt;

but once started, the action is hastened when these links slow their rotation and return energy to the bolt member of the system.

In another weapon, this delay is obtained by forcing a block of metal out of the path of the bolt. As this part

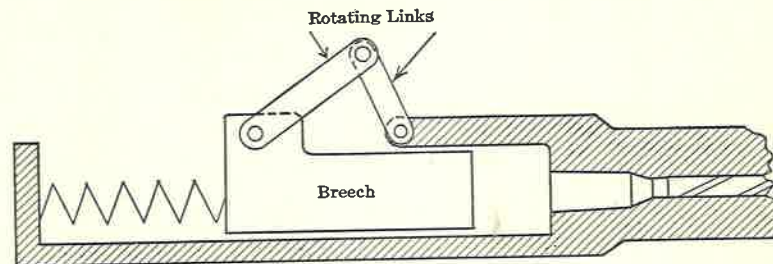

FIG. 15. Action of Schwarzlose Machine Gun.

moves in a direction nearly at right angles to the path of the bolt, the lateral force is small and the mass of the blocking part is effectively increased.

5.4 SHORT RECOIL

In the discussion of the inertia action it was stated that the breech is opened by gas pressure in the chamber. When it is desired to delay the action beyond the persistence period of the gases, some other means must be found to provide this separation. This action of separation is commonly called *acceleration*, because the motion of the *bolt* is accelerated. In this type of action, the maximum velocity of the bolt may be four or more times its velocity before acceleration.

The recoil of the barrel relative to the frame or receiver of the gun is employed to move the mechanism to the point of acceleration. While an accelerator is not found in delayed inertia actions, it may likewise be missing in a short recoil action if the barrel is *decelerated* instead of the bolt being *accelerated*.

The elements of this type of mechanism are well portrayed in U. S. Patent 571,260, which was issued to Hugo Borchardt

in 1896. This patent illustrates the principles which have been continued into the later Borchardt and Luger pistols. Figure 16 is taken from this patent.

In Figure 16a the gun is shown in its closed position. It will be noticed that the pivot 2 is slightly below the line joining pivots 1 and 3. After firing, recoil causes the barrel,

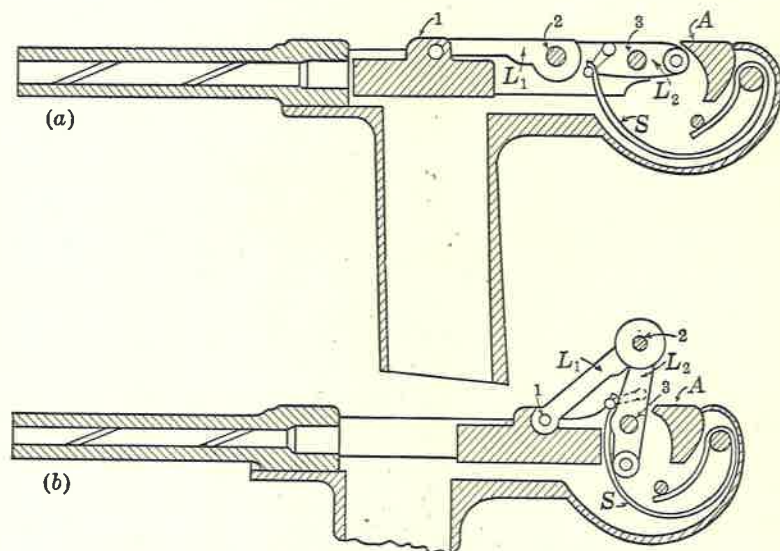

FIG. 16. Short Recoil Pistol (Borchardt).

bolt, and barrel extension to move rearward, together with the toggle mechanism, without the links of the toggle changing their relative positions. After a short travel, the rear end of the link L_2 strikes against the accelerator A , which is fastened to the frame of the pistol. Further motion causes the rear end of L_2 to be depressed by A , causing pivot 2 to swing up and break the joint of the toggle. From this time on the mechanical advantage of the mechanism becomes more favorable and the bolt is withdrawn from the breech end of the barrel. At the end of the motion, the parts have reached the position shown in Figure 16b, in which the

spring S is shown strained. When the energy of the round is expended, this spring relaxes and returns the mechanism to its original position.

It is to be noted that this mechanism could be classed either as delayed inertia or short recoil, depending on whether there is pressure remaining in the chamber when L_2 strikes the accelerator A . The absence of a visible breech lock could cause this gun to be classed as a delayed inertia weapon.

Calculation of the motions of this weapon would be much more complicated than those for the simple inertia gun. Action would be in free recoil until the link strikes the cam, after which a step-by-step method based upon conservation of the momentum in the moving system could be used.

5.5 LONG RECOIL

When the short recoil type of action is employed, it is necessary to stop the barrel motion within a few calibers. It follows, then, that the energy in the barrel must be absorbed within this distance or that it must be transferred to other members. In either case, the action on the receiver must be quite violent. The long recoil type of action utilizes a longer period, both in time and distance, to stop the motion of the barrel. Owing to the fact that the combined mass of the barrel and bolt is moving at the free recoil velocity or less, the time required for the firing cycle is very long. Hence, this action can be used only where a slow rate of fire is desired.

A schematic long recoil action is shown in Figure 17. In addition to the barrel and bolt, the receiver contains separate return springs for the barrel and bolt. The barrel is provided with a cam extending beyond the bolt. This cam is arranged so as to contact the bolt catch when in its forward position. Figure 17a shows the mechanism "in battery" before firing.

In Figure 17*b* firing has taken place and recoil has been completed. The bolt and barrel springs are compressed and possess the energy necessary to return these parts to their original forward positions. While the barrel is free to return, the bolt is now caught on the catch and remains at the rear.

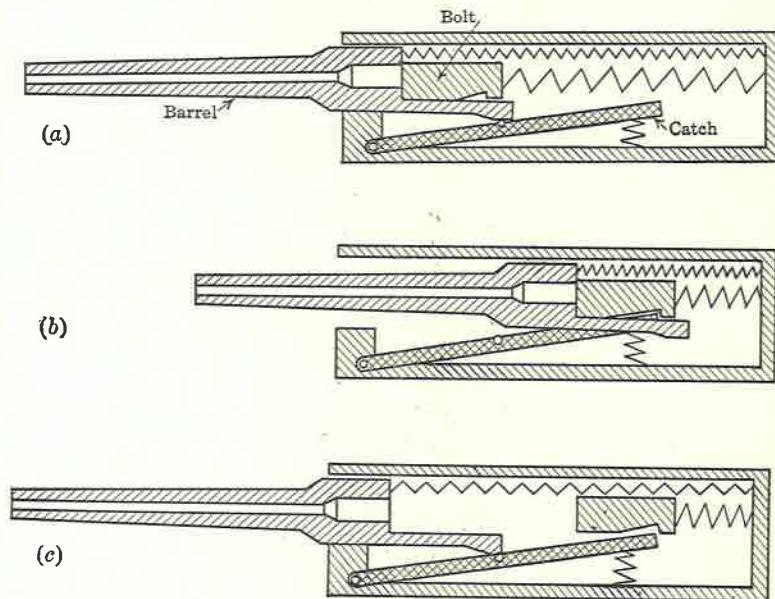

FIG. 17. Elementary Long Recoil Action.

While the bolt is held, the barrel spring sends the barrel forward and at the beginning of this movement the empty cartridge case is extracted from the chamber. When the barrel reaches its forward position, the barrel cam actuates the bolt catch, releasing the bolt. This is shown in Figure 17*c*. After release, the bolt is driven into place by the bolt spring and the action is ready for the next shot.

5.6 GAS OPERATION

In the systems so far described, the motion (or power) is available at any point in contact with the barrel. A *gas-operated* system differs in that the gas energy has to be led

from its source in the bore to the gun mechanism. This is usually done by means of a *piston* or *operating rod* which acts directly on the bolt. If the bolt is actuated in this manner, the accelerator, which is a prominent feature of short-recoil actuated weapons, is not required. A gas-operated machine gun is an elaboration of the elements sketched in Figure 18.

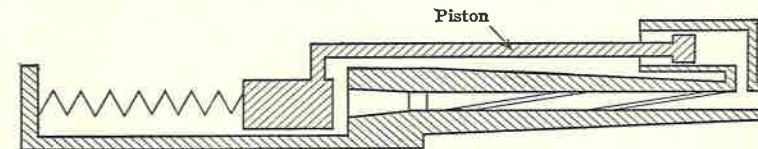

FIG. 18. Elementary Gas-Operated Gun.

In this sketch the actuating rod is shown attached to the bolt. When the gas emerges from the barrel and strikes the piston, the actuator is driven smartly to the rear, opening the breech and compressing the spring.

The form of gas port and piston shown in Figure 18 is the one most commonly used. Figure 19 depicts it in more detail. Here the gas port directly connects the bore and the

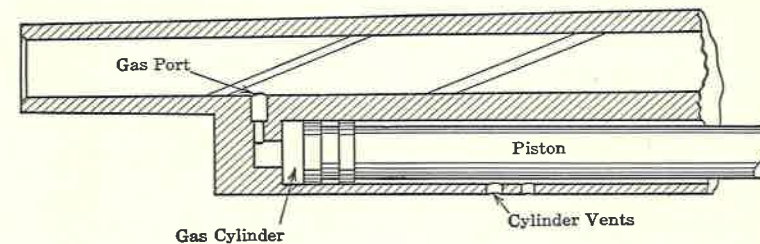

FIG. 19. Gas Port and Piston.

gas cylinder. These parts are usually so constructed as to have several ports of different sizes instantly available. Thus, an adjustment to provide more power is incorporated and, as the parts are removable, the holes are more easily kept clean.

This gas cylinder is the type used on the Browning automatic rifle, the Bren gun, the Colt machine gun, the M1

(Garand) rifle, the Hispano-Suiza automatic cannon, and a host of others.

There is a variant of this system that is interesting from an engineering point of view although not currently used in practice. Study of Figure 19 shows that the gas is first forced into the cylinder at the time the bullet passes the gas port. The pressure of the gas in the cylinder is released when the bullet leaves the muzzle of the gun. This time interval is very short, as the port is placed about 6 in. or less from the muzzle. Consequently, the gas pressure in the cylinder has hardly built up and started the parts in motion when the bore pressure drops and the gas in the cylinder flows back into the bore. Thus, the entire action of the gas upon the piston is a sharp blow.

In order to utilize the high pressure of the gas to better advantage, J. C. White proposed that the cylinder be equipped with a cutoff valve so that the gas could be trapped and could expand against the piston, delivering a more even effort. This renders the action less sensitive to dirt and other accidental frictions after the bullet has left the barrel. Figure 20 is adapted from White's U. S. Patent 1,907,163.

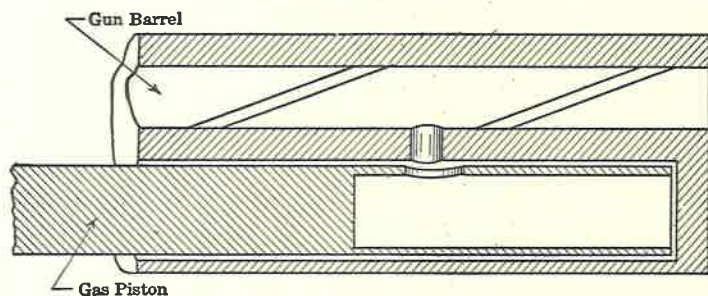

FIG. 20. Gas Expansion System (White).

The types of gas cylinder described work well when used near the muzzle. As they tap the gases after they have completed their work, little efficiency is lost. However, the gases are usually voided into the mechanism and a considerable

accumulation of carbon soon encrusts the parts. To avoid this, there has been developed a closed system. This is shown in Figure 21. This type can be used at any point along the barrel, for there is no loss of gas, all the gas going into the chamber being eventually returned to the bore. In this system the piston is not attached to the operating rod nor to the mechanism. Instead, the piston strikes the operating rod a sharp blow and the remainder of the action is performed

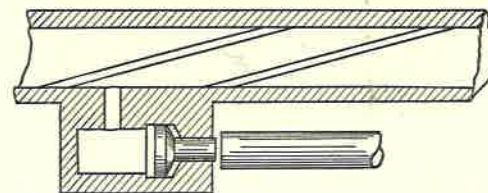

FIG. 21. Gas Tappet Piston.

by the momentum exchanged at that instant. The main values of this system are that it does not permit the escape of gas into the mechanism, and that, using a short tappet stroke, sealing is readily obtained. The tappet itself can be made removable for cleaning or replacement. On the other hand, this unit requires that all the operations of the gun be energized by one instantaneous impact. This appears to be inferior to the extended action of the expanding gases as used in White's method.

The gas actions described so far have been the sole source of actuation for the gun. There remain systems in which the gas is used to assist other types of action or to "boost" other sources of power. The most common of these devices is the *muzzle booster*. Its elements are shown in Figure 22. This booster is usually used in connection with a recoil action and is merely a partially enclosed space immediately before the muzzle. The orifice in the chamber, while large enough to permit the passage of the bullet, is so sized that the escape of the gases is retarded. The chamber, then, becomes filled for a short period of time with gases at a pressure of about 6,000

or 8,000 lb per sq in. If this pressure is exerted over a muzzle face area of 1 or $1\frac{1}{2}$ sq in., it is readily seen that a considerable boost can be given to the normal recoil of the barrel.

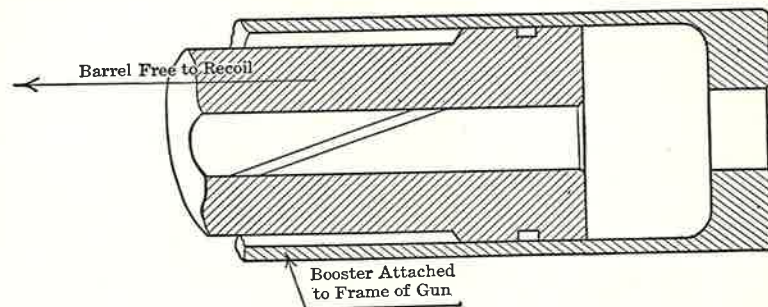

FIG. 22. Muzzle Booster.

To supply a boosting action in a situation where the muzzle pressure was much too low to be of any value, D. M. Williams invented the floating chamber. This design (Fig. 23) was first used to operate the mechanism of the cal. .30 Browning machine gun when used as a training machine gun firing cal. .22 cartridges. In this system, the barrel is cut transversely a short distance in front of the chamber. The forward part is fixed, and only the breech portion recoils. In

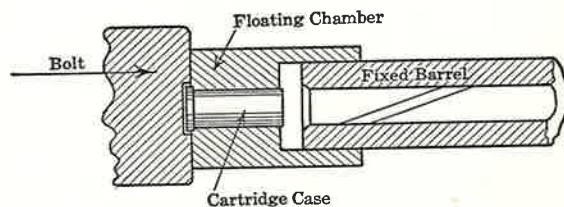

FIG. 23. Floating Chamber System.

this case, the gases, when at their highest pressure, are spread over a large area and do not have the mass of the entire barrel to move. The piston must be fitted rather closely to its chamber, so that there is only small loss of gas, which would otherwise impair the operating efficiency of the weapon.

5.7 COMPOUND SYSTEMS

Several fundamental systems of automatic gun operation have been outlined. These must not be thought of as representing all the variations to be encountered in practice. Various modifications and combinations based on these elements exist. For example, the Hispano-Suiza automatic cannon is a delayed-inertia gun in which the action is unlocked by the gas pressure and the delay is secured by placing the gas port at the proper position along the barrel. The muzzle booster is often used with recoil-operated guns to provide additional power. Early recoil-operated guns utilized the recoil of the entire rifle against a floating butt plate to operate the mechanism. In these combinations and variations lies the essence of invention and improvement of the art.

BIBLIOGRAPHY

- CURTI, P., *Automatische Waffen*, Frauenfeld, Huber & Co., 1936.
 DEVOUGES, MARCEL, *L'Avènement des Armes Automatiques*, Paris, Charles-Lavauzelle & Cie., 1924.
 HATCHER, J. S., "Automatic Firearms," *Army Ordnance*, Vol. XIII, p. 269, 1933.

CHAPTER SIX

AUTOMATIC WEAPONS—EXISTING TYPES

6.1 INERTIA WEAPONS—THE M3 SUBMACHINE GUN

The U. S. Submachine Gun, Cal. .45, M3 is an example of the simple inertia system. Its principal characteristics are:

Length	23 in.
Weight	9 lb
Rate of fire	450 rpm
Barrel length	8 in.

No forces except the inertia of the bolt and the force of the two driving springs close the breech against the powder pressure. Figure 24 shows a simplified sectional sketch of this

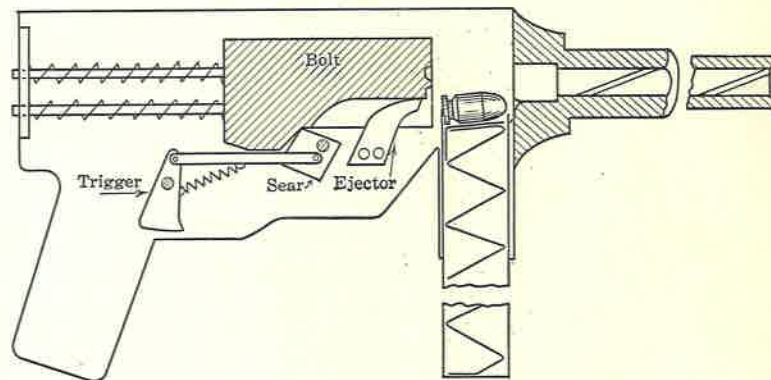

FIG. 24. U. S. Submachine Gun, Cal. .45, M3.

weapon. The magazine is below the bolt, and when the latter is in the rear position the magazine spring forces the topmost cartridge up against the magazine lips. As the bolt moves forward it pushes this top cartridge into the chamber.

The firing pin is fixed in the face of the bolt and the round is fired as the bolt closes the breech. The 230-grain bullet has a muzzle velocity of about 900 ft/sec and a momentum of 0.92 lb-sec. As the bolt weighs 2 lb, the gases impart to it an energy of 6.9 ft-lb.

The characteristics of the two driving springs are: initial compression 2.8 lb, spring rate 0.58 lb/in. Using the methods of Chapter 5, it is found that the bolt recoils 8 in. and that the time of recoil is 0.097 sec. This is equivalent to a cyclic rate of 310 rounds per min. The variation of this value from the actual firing rate of 450 rounds per min is to be noted. Differences may be ascribed to friction, hysteresis in the springs, case extraction resistance, etc., for which allowances should have been made in the computations. That these unconsidered resistances have a large effect is shown more positively when it is noted that Equation 30 computed a recoil of 8 in., whereas the construction of the gun permits only 6.5 in.

As the bolt recoils from the barrel, the empty cartridge case is withdrawn from the chamber because the case is held against the face of the bolt by the extractor. After a recoil of $1\frac{5}{8}$ in., the bolt passes over the top of an ejector fixed to the lower part of the gun. As the extractor is on the right side of the bolt, the fired case is thrown upward and to the right of the gun. The bolt then continues its recoil motion alone, returning forward under the influence of the driving springs. If the trigger is held and the sear depressed, the bolt will continue forward and fire as before. If, however, the sear is not depressed, it will hold the bolt and prevent further firing.

It should be noted that this weapon represents the simplest type. It fires a low-powered cartridge and is fed by a magazine spring so that neither a complex locking system nor a precise feeding mechanism is required. How the necessity

for these items greatly complicates the mechanism of the gun is shown by the following sections.

6.2 RECOIL-OPERATED WEAPONS—THE BROWNING MACHINE GUN

As previously stated, the recoil-operated gun can be distinguished from the inertia gun by the presence of an accelerator. This type of action is well illustrated by the Browning machine gun, which is today perhaps the best-known machine gun. The specific data in this paragraph are those of the cal. .30 M2 aircraft model. The principal characteristics are:

Overall length	40 in.
Barrel length	24 in.
Bolt length	5.9 in.
Barrel recoil	0.60 in.
Bolt motion	4.38 in.
Pitch of feed belt	0.51 in.
Total weight	23 lb
Barrel group weight	4.88 lb
Bolt group weight	1.94 lb
Recoiling weight	6.82 lb
Weight of firing pin assembly	0.12 lb

The mechanism of this gun will be divided into three parts for study:

- (a) Feeding cartridge into chamber, locking, extracting, ejecting.
- (b) Firing and cocking.
- (c) Feeding belt through gun.

This division is possible because the mechanism consists of three integrated kinematic chains, each performing one of these cycles.

The feeding-locking-extracting-ejecting chain is depicted in Figure 25. The upper view in this sketch shows the mechanism loaded and ready to fire. When the cartridge is ignited, the barrel is driven to the rear by normal recoil, which is resisted by the mass of the barrel and bolt combination and by the compression of the driving spring and barrel plunger spring. This recoil is soon assisted by the muzzle gases, which escape into the chamber of the muzzle booster.¹

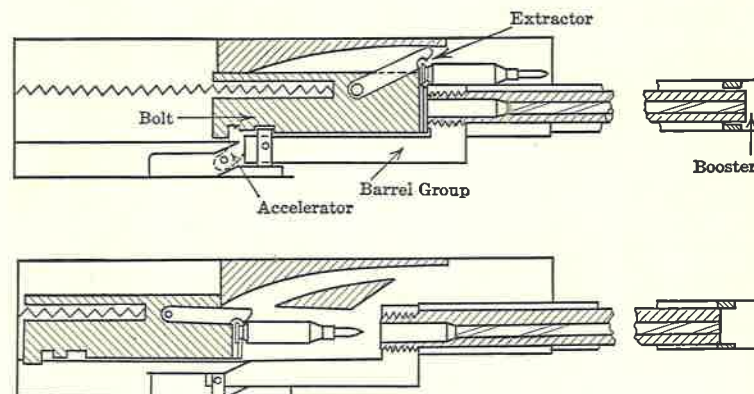

FIG. 25. Browning Machine Gun—Feeding Chain.

The action of the gun at this time can be followed more closely by additional reference to Figure 26. These curves, representing the motions of the bolt and barrel groups during the firing cycle, were obtained experimentally. (When this record was made, the gun was firing a 172-grain projectile at a muzzle velocity of 2,700 ft/sec. The powder charge was 45 grains.) The lower curve shows the motion of the barrel, and the upper that of the bolt. As these two groups are locked together at the time of firing, they recoil together for the first 0.0052 sec. From the slope of this curve, the velocity in this interval and, hence, the energy and momentum may

¹ This booster action does not change the classification of this gun as a recoil-operated weapon. Essentially the same mechanism was long used without a booster until an increased rate of fire was desired.

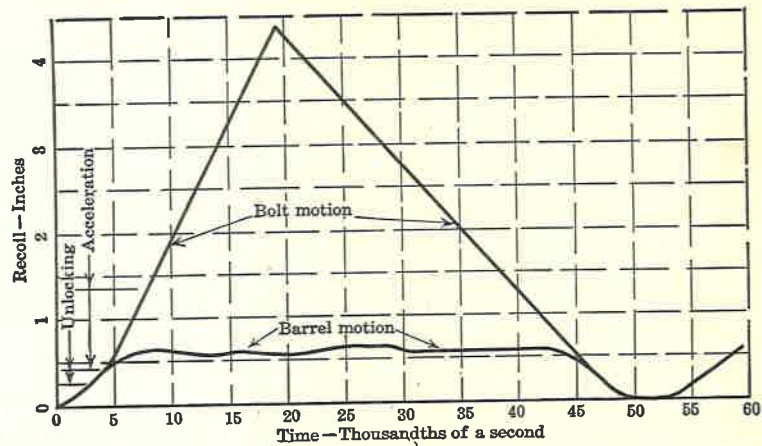

FIG. 26. Browning Machine Gun—Time-Displacement Curves.

be determined, since the weight of the recoiling parts is known. This velocity is found to be 15.3 ft/sec. The corresponding energy is 25.00 ft-lb.

In Chapter 3 the method of determining the free recoil velocity of a gun has been given. Applying that method to this case, a velocity of 10.95 ft/sec is obtained. The difference between this value and that determined experimentally is $15.3 - 10.95 = 4.35$. This additional velocity has been achieved by the use of the muzzle booster.

By the time the moving parts have recoiled 0.0052 sec (or 0.45 in.) the breech lock has been cammed down and the accelerator has begun to swing into place beneath the bolt. The accelerator is a curved lever acting on a pivot fixed to the frame of the gun. This lever pries the bolt away from the barrel extension because the contacts between it and these members are at different distances from the accelerator pivot. The energy content of the gun at the instant the bolt and barrel group separate may be tabulated as follows:

	VELOCITY	ENERGY
Bolt	24.2 ft/sec	17.6 ft-lb
Barrel group	8.1	6.9
Driving spring	0.5
Total		25.0 ft-lb

Thus no energy has been lost in the redistribution of velocities.

The barrel is soon brought to rest by the barrel plunger spring. As the spring can only absorb 0.19 ft-lb, and the barrel group contains 6.9 ft-lb, it is apparent that the stopping of this unit will be attended with great impact. That this is true is shown in Figure 26, as the barrel group rebounds several times while locked in its rear position. Indeed, the function of this spring is more to provide a latch action than to act as a buffer for the barrel group.

The bolt continues to the rear, arriving at the backplate with a velocity of 20.2 ft/sec (12.32 ft-lb energy). Since it was accelerated, an additional 5.28 ft-lb has been stored in the spring.

The turn-around action of the backplate buffer is abrupt and violent. In fact, it is too rapid to be observed by the method used here, all action being completed in 0.001 sec. Energy and momentum relations for this period are:

	VELOCITY	MOMENTUM	ENERGY
Before striking	20.2 ft/sec	1.22 lb-sec	12.32 ft-lb
After striking	-13.0	-0.78	5.10
Momentum change		2.00	
Energy loss			7.22

The average force required to produce this change in momentum is

$$F = \frac{mv}{t} = \frac{2.00}{0.001} = 2,000 \text{ lb}$$

Thus a very large blow lasting only for an instant is struck upon the backplate at this time.

The forward velocity of the bolt is composed both of velocity imparted by the rebound from the backplate and by the energy transferred from the driving spring.

The action of the bolt has been described in great detail because this component contains most of the mass of the system and remains most nearly unaffected by the other

actions of the gun. Further, all the other operating parts of the gun are connected to the bolt, and all the functions of the gun are performed as a result of its motions. The functions most directly performed by the bolt are those of feeding the cartridge into the chamber and extracting and ejecting it. These are also illustrated in Figure 25.

The cartridge to be fed next into the chamber lies above the chamber at the rear of the gun barrel. When the bolt is in its forward position, a hook, called the extractor, is positioned so that it catches in the extracting groove of the cartridge case. The lower end of this extractor is pivoted in the bolt and the upper end is controlled by two cams, one on the sideplate and the other fixed to the cover. As the bolt recoils, these cams force the extractor downward. This combination of downward and rearward motion withdraws the cartridge from its feed belt and lowers it to the level of the chamber. On the forward stroke, this motion is completed and the cartridge is fed into the chamber. After the cartridge is started into the chamber, the sideplate cam causes the extractor to rise from the cartridge and go forward to its initial position, where a new cartridge awaits it.

The forward portion of the bolt is provided with a shallow slot which fits the head of the case. Because of its undercut shape, it is called the T slot. The hook of the extractor is so related to this T slot that as it lowers the cartridge, the head of the case engages in and moves down the T slot. Extraction is performed by the cartridge case being pulled from the chamber by means of this T slot. Ejection is accomplished as the fired case is forced down the T slot by the following round. To insure smoothness of ejection and to offer a support to the case being fed, the extractor has a depending arm, the ejector, which bears against the top of the ejected case and also against the bottom of the new round.

To obtain an estimate of the forces involved in feeding a cartridge into line with the chamber, note that the cartridge

initially rests 1.73 in. above the center line of the bore. It is brought down this distance in the recoil stroke of the bolt, after unlocking has taken place. Figure 26 shows this time interval to be 0.014 sec. To obtain the lowest acceleration possible, assume uniform acceleration and deceleration over this distance. Then

$$a = \frac{2 \cdot 1.73/2}{12(0.014/2)^2} = 2,940 \text{ ft/sec}^2$$

As the weight of this cartridge is 400 grains, the force exerted on the extractor during this motion must be

$$F = \frac{400 \cdot 2,940}{7,000 \cdot 32.2} = 5.2 \text{ lb}$$

On the counter-recoil stroke, conservation of energy is not as well demonstrated by this record as on the recoil stroke. This is because of the many gun functions which were not

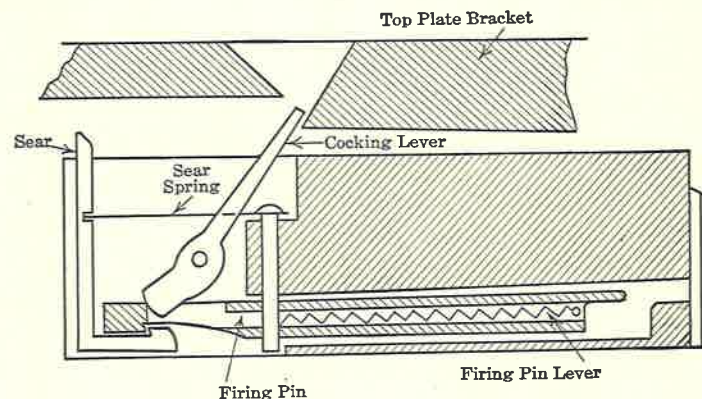

FIG. 27. Browning Machine Gun—Firing Chain.

measured. The same functions of acceleration and locking are performed as before but in reverse order. The scale on Figure 26 shows that the entire cycle required 0.052 sec to complete, a cyclic rate of 1,150 rounds per min.

The firing and cocking mechanism of the gun is shown in Figure 27. This depicts only a cross-section of the bolt

assembly, together with the top-plate bracket. The bolt must be envisioned as moving laterally with respect to the latter, which is fixed to the receiver of the gun. When the bolt recoils, the top of the cocking lever is caught in the top-plate bracket, and, rotating on its pin, its lower end cams the firing pin backward, compressing the firing pin spring against the pin of the sear spring. When the firing pin has been drawn fully to the rear, the sear is snapped into the sear notch by the action of the sear spring. On the forward stroke of the bolt, the firing pin is held by the sear and the cocking lever is returned to its former position by the top-plate bracket cam to be ready for the next cycle. Release of the firing pin is accomplished by some form of trigger (external to the gun) which pushes the sear from the firing pin.

The cartridges for this gun are furnished in a belt from which the cartridges can be withdrawn in a direction parallel to their long axis. This belt is fed through the gun by a ratchet mechanism shown in Figure 28. This view shows the

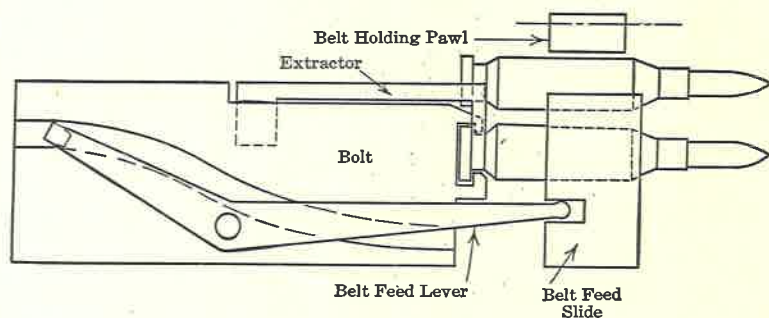

FIG. 28. Browning Machine Gun—Belt Moving Chain.

gun as seen from above. The ratchet feed consists of the belt-feed slide (including the feeding pawl) and the belt-holding pawl. Reciprocating motion of the former causes alternate engagement of these two spring-loaded pawls and advances the belt round by round. The feed slide is actuated by a lever, pivoted to the cover and having on one end

a lug depending into a cam cut in the bolt. As the bolt recoils, the rear end of the feed lever follows the cam and the slide is moved accordingly.

The pitch of the feed belt is 0.51 in.; the time available for the feeding of the belt (as taken from Figure 26) is 0.025 sec. Hence, the belt must move with an average speed of $0.51 \div (0.025 \cdot 12) = 1.67$ ft/sec. As this type of feed mechanism causes the belt to move by steps rather than by a continuous motion, the entire belt must be set in motion on each round.¹ For an estimate of the work involved in moving an ammunition belt, suppose that a load of 25 cartridges is being raised. Such a belt will weigh 1.43 lb and the work involved in lifting it 0.51 in. is a negligible amount. Next, consider the acceleration forces acting on this belt. In the absence of any other data, it is assumed that a constant acceleration is applied for half the period and a constant deceleration for the other half. This can be expressed as

$$a = \frac{2s}{t^2} = \frac{2 \cdot 0.51}{(0.012)^2 \cdot 12 \cdot 2} = 295 \text{ ft/sec}^2$$

This acceleration is 9.2 times that of gravity and gives an indication of the magnitude of the accelerations which exist in weapons of this type.

6.3 RECOIL-OPERATED WEAPONS—THE MAUSER MACHINE GUN, MG151

The previous section described a gun in which each function was performed by a kinematic chain which acted in a plane. It was noticed that the action could be completely depicted by one view in the proper plane. This section, while describing essentially the same functions, shows them in a gun in which three space dimensions are utilized. In the MG151 the same functions of recoiling, unlocking, accelerat-

¹ In practice, the elasticity of a long belt absorbs much of this irregular motion.

ing, feeding by a ratchet system, extracting, and ejecting are performed as in the Browning machine gun. This second example of this type of mechanism is given to show how the same general scheme may be redesigned in actual construction. One important difference in functioning exists, however. The German gun uses a push-through belt link. This type of link, which is more fully described in Chapter 8, is open on its lower side and does not require that the cartridge be pulled to the rear to be removed from it. This change permits simplification of the gun mechanism in much the same manner as a two-cycle gas engine can be simplified over a four-cycle engine.

The principal characteristics of this gun are:

Length	75 in.
Weight	80 lb
Rate of fire	850 rpm
Barrel length	50 in.

The general arrangement of the gun is shown in Figure 29. As the mechanism is difficult to depict when assembled, the lower part of the figure shows the main operating components in an exploded view. The gun is shown as readied for firing. There is no firing pin spring. The firing pin is held in the bolt body and fires by inertia when the bolt moves forward. A cartridge is shown in the feedway, moved into the loading position. This is done by drawing the bolt¹ to the rear by pulling a cable which extends through the feed cam. This feed cam has a helical cut through which the bolt is actuated. Hence, motion of the bolt will cause rotation of the cam, and also oscillation of the feed rack which engages the feed cam at its forward end. This feed rack is provided with a ratchet system which feeds one round into position at a time. When the bolt moves rearward, a cartridge is drawn

¹ The word "bolt" will be used in this section to designate the combination formed by the assembly of the bolt head and the bolt body.

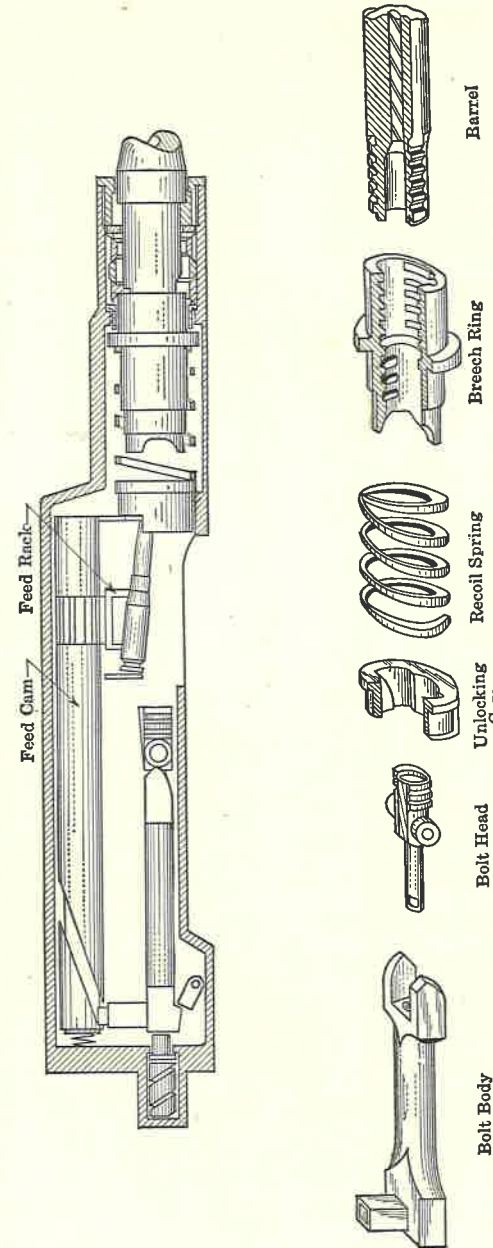

FIG. 29. Mauser Machine Gun, MG151.

to the center of the feedway and comes to rest in the slot provided there. When the sear is moved, the bolt is pushed forward by the driving spring (contained inside the feed cam). As the face of the bolt head passes under the feedway, a raised portion strikes the head of the cartridge and drives it into the chamber. At this time the cartridge is not directly controlled but flies free, directed only by the shape of the slot in the feedway and the interior surfaces of the unlocking cam and breech ring, through which it passes.

Continued motion of the bolt carries it to the point where the rollers of the bolt head strike the locking cams on the rear face of the breech ring. The forward motion of the bolt head is thus changed to a rotational motion. The cams on the breech ring permit 45 degrees of rotation, which constitutes complete locking of the weapon. While the bolt head has been rotating, the bolt body has been following it closely, just as fast, indeed, as the ears of the forward end of the bolt body move along the bolt head rollers. This action closes the gap between the bolt head and the bolt body, and as this gap closes, the firing pin is moved through the face of the bolt head and fires the cartridge.

After the gun fires, the assembly—consisting of barrel, breech ring, bolt head, and bolt body—recoils and compresses the recoil spring. This common motion persists for $\frac{3}{4}$ in., when the bolt head rollers strike the internal cam surface of the unlocking cam. The bolt head is rotated by this action, and as it rotates, it forces the bolt body backward by the cam surfaces on the ears of the bolt body. During this period, the bolt head is moving at the same velocity as the barrel, while the bolt head is moving at a greater speed. Hence, this is the period of acceleration.

When rotation has been completed and the bolt rollers rest on the ends of the bolt body, the bolt head is completely unlocked. At this instant, the bolt head is moving with the same velocity as the barrel, while the bolt body is moving at

the accelerated velocity. Now the bolt head is no longer connected to the breech ring, but it is connected to the bolt body and governed by it. Here are two connected components moving with different velocities. This is, then, a case of direct impact, and a new, common velocity will be attained.

While the barrel, together with the breech ring and bolt, is recoiling, it compresses the recoil spring. This, of course, causes deceleration of the barrel recoil motion, and, after the bolt is unlocked, the barrel is brought to rest and then returned to its initial position by this spring.¹

After completion of the unlocking and acceleration of the bolt head, the bolt assembly continues to the rear, compressing the driving spring and finally coming to rest upon the sear (unless, of course, the latter is depressed).

6.4 GAS-OPERATED WEAPONS—THE JAPANESE LIGHT MACHINE GUN, MODEL 99

The Japanese light machine gun, Model 99, is a gas-operated gun. Its main characteristics are as follows:

Caliber	7.7 mm (0.303 in.)
Weight	20 lb
Length	42 in.
Barrel length	21.6 in.
Feed	Magazine, vertically downward

The essential elements of this gun are sketched in Figure 30.

In the position shown in this sketch, the mechanism is locked and fired. The bolt is prevented from opening by the bolt lock, which can move only vertically in slots in the walls of the receiver. After the bullet moves down the bore and uncovers the gas port, the gases pass through the port

¹ Here the mechanism differs from the Browning construction, as in the latter the barrel is retained in the rear position until urged forward by the counter-recoiling bolt. The German construction obviates the necessity for a latch arrangement to hold the barrel rearward during this period.

and strike the forward end of the slide. The slide moves rearward, opposed only by the driving spring, which it compresses. As the slide moves, it draws the firing pin rearward because the firing pin is set in a shallow groove in the top of the slide. After further motion, the post on the top of the slide draws back the bolt by striking against the rear end of the recess in the bolt. This bolt motion cannot take place

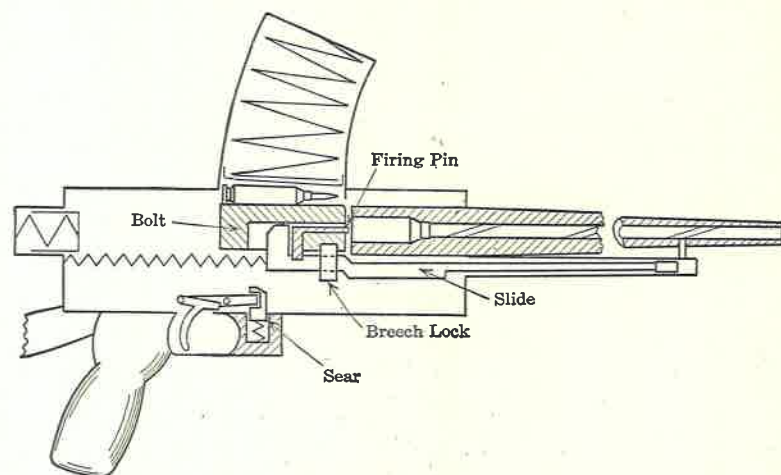

FIG. 30. Japanese Light Machine Gun, Model 99.

until the slide has moved sufficiently to draw down the bolt lock by means of the inclined surfaces on the slide. Thus, the bolt must remain securely locked to the receiver at all times when the firing pin is not in its withdrawn position.

After the lowering of the bolt lock, the bolt is carried to the rear a distance sufficient to permit a new cartridge to feed downward from the magazine. Meanwhile the empty cartridge case has been withdrawn from the chamber by the extractor on the front of the bolt. The ejector (not shown) is a curved member pivoted to the side of the receiver. As the rear of the bolt strikes it, the front end is pivoted around and the case is thrown through the ejection port in the right side of the receiver.

When the energy of the slide is all transmitted to the driving spring or the backplate buffer spring, the slide returns forward and the motions described are performed in reverse order. After the breech lock is moved up, the slide moves the firing pin forward to ignite the primer of the cartridge which the bolt has pushed into the chamber.

An additional safety feature to prevent premature motion of the firing pin is incorporated. A small piece rides inside the bolt in front of the firing pin. This piece can be pushed out of the way of the pin only when the bolt is at the proper position, in line with a recess in the receiver wall into which the piece moves.

All the major parts of this weapon move in straight lines. The locking of the bolt to the receiver is positive and timed with the movement of the firing pin.

Feeding, as in most magazine-fed weapons, is accomplished simply. The magazine spring forces the first cartridge down into the path of the bolt, and the forward motion of the bolt drives it into the chamber.

6.5 COMPOSITE SYSTEMS—THE HISPANO-SUIZA AUTOMATIC CANNON

In addition to the types of mechanism described in the preceding sections, which used a single source of energy for their operation, there are others which utilize a coordinated series of sources. For example, the Hispano-Suiza 20 mm automatic cannon utilizes high-pressure gas to unlock the bolt but uses low residual chamber pressure to retract it and compress the driving spring. The principal components of this gun are shown in Figure 31.

The mechanism is shown retracted, with the bolt caught on the sear and the driving spring compressed. When the sear is withdrawn downward, the driving spring forces the breechblock assembly toward the muzzle and the magazine feeds the fresh cartridges downward. They come to rest

slightly within the path of the bolt. When the bolt passes, it forces the lowest cartridge ahead of it, into the chamber, and the forward motion of the breechblock itself is halted when it strikes the rear face of the barrel. The two breechblock slides (one on each side) continue their motion and carry down the breechblock lock. As the forward end of the breechblock lock is pivoted to the bottom of the breechblock, the rear end swings downward and locks against the breechblock key, which is firmly fixed in the receiver of the gun.

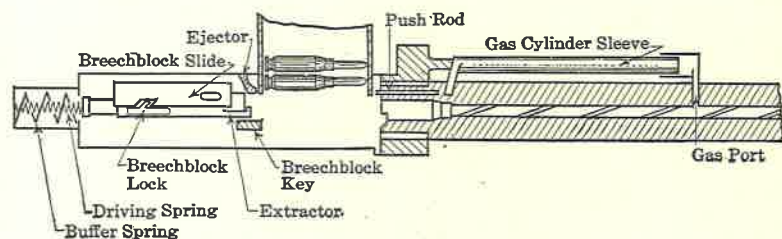

FIG. 31. Hispano-Suiza 20 mm Automatic Cannon.

With the gun thus securely locked, the breechblock slides continue forward a short distance.

As the firing pin is pinned between the breechblock slides, it is carried forward with them and ignites the cartridge.

After the cartridge has been fired no gun action can occur until the bullet has passed the gas port. Then gases at high pressure pass through the gas cylinder and drive the gas cylinder sleeve toward the rear. This in turn moves the push rods against the breechblock slides. As the breechblock slides go to the rear they first withdraw the firing pin and then cam up the rear end of the breechblock lock. The timing of the mechanism to prevent premature unlocking is done by dimensioning the breechblock slides to secure the desired delay. This timing is also dependent upon the exact load of powder used. The travel of the slides to withdraw the firing pin is 0.08 in., while 0.35 in. further travel is required before the lock is completely released.

When the breechblock lock is disengaged, the gases remaining in the chamber drive the breechblock assembly to the rear, compressing the driving spring. The fired cartridge case is held to the face of the breechblock by an extractor below it. A fixed ejector is mounted above the breechblock, at the rear of the feed opening. As the breechblock passes under it, the upper part of the case head strikes it and the case is pivoted downward, about the extractor, and is thrown out of the gun. At the same time, pressure of the magazine spring forces another cartridge down in front of the breechblock.

The breechblock continues to the rear, compressing the driving spring, and is then returned toward the barrel. If the sear is depressed, the breechblock continues over it and automatic firing continues. If the sear is released, the sear spring forces the sear into a notch on the underside of the breechblock lock, stopping the forward motion of the breechblock assembly.

BIBLIOGRAPHY

- CURTI, P., *Automatische Waffen*, Frauenfeld, Huber & Co., 1936.
- HATCHER, J. S., *Textbook of Firearms Investigation, Identification, and Evidence*, Plantersville, S. C., Small Arms Technical Publishing Co., 1935.
- HATCHER, J. S., WILHELM, G. P., and MALONEY, H. J., *Machine Guns*, Menasha, Wis., George Banta Publishing Co., 1917.
- JOHNSON, M. M., JR., and HAVEN, CHARLES T., *Automatic Arms*, New York, William Morrow & Co., 1942.
- SMITH, W. H. B., *A Basic Manual of Military Small Arms*, Harrisburg, Military Service Publishing Co., 1943.
- Textbook of Small Arms*, London, H. M. Stationery Office, 1929.
- WEISS, R., *Die Handfeuerwaffen (ihre Entwicklung und Technik)*, Leipzig, Teubner, 1912.
- WILSON, R. K., *Textbook of Automatic Pistols*, Plantersville, S. C., Small Arms Technical Publishing Co., 1944.
- WIMMERSPERG, H. V., "Die Maschinengewehre der Kaliber 6.5 bis 8 mm," Berlin, *Z. Ver. deut. Ing.*, p. 1153, 1939.

CHAPTER SEVEN

TRIGGER AND SEAR MECHANISMS

7.1 INTRODUCTION

The study of trigger mechanisms may well constitute a separate section of gun design, for this particular portion of the gun is relatively independent of the type of automatic action chosen. Moreover, the mechanical disposition of the other gun parts is normally undertaken first, so that the configuration of the trigger and sear mechanism is designed to fit in what space is left. Perhaps the title of this chapter could be changed to some more general term as "firing-pin-release mechanism," for in weapons designed for remote control, there is no actual *trigger*. Instead the sear mechanism is carried to a point where it may be actuated from the outside of the gun, and contact is made with an external energizing device, which may be called a solenoid, or side-plate trigger.

Sear mechanisms belong to the class of mechanisms known as *latches*. Their purpose is to release a large force by the application of a much smaller one. The operation of hanging up the latch or *cocking* is performed by the mechanism during the performance of other functions.

As indicated above, the design of these mechanisms is greatly controlled by the space available and, therefore, there is a great deal of art in their design. They vary greatly in complexity, from simple mechanisms in which the sear is a part of the trigger and is pulled directly out from before the hammer or firing pin to more complicated arrangements which have been devised to fire the various barrels of a multi-barreled gun in changeable, preselected orders.

7.2 FUNCTIONING REQUIREMENTS

The basic requirement of a sear mechanism is reliability. The gun must fire when, and only when, it is required to. There must be no possibility that an automatic action will fire more than one round when only one is desired. If the gun is capable of firing at different rates of fire, only the selected rate shall be produced. Correspondingly, if there is a change lever or selecting mechanism, the setting of this control must be simple and positive. Finally, in addition to starting the firing, the control must be capable of stopping it when desired. Outside of a burst gun, there is probably no greater hazard than a runaway or uncontrolled gun.

The above requirements indicate that the sear mechanism is a most important unit. It follows that its functioning when the gun is old and worn must be as precise as when the gun was first constructed. The design should be such that important contact surfaces are not subject to impact or to wearing during the recoil and transport of the weapon. Springs must be so designed and stressed that they are not subject to setting and loss of strength.

The actual operation of the sear is one requiring precision, that is, the latch should be either on or off; there must be no middle ground, no region where the firing pin may or may not release.

The force required to operate the sear must be kept quite small. This, indeed, is its reason for being. This force must be low in the case of hand-held guns in order that pulling the trigger shall not disturb the firer's aim. For guns fired remotely, it must be low in order to make use of small forces and prevent excessive loading of available power supplies.

The location of the sear mechanism with regard to the outside of the gun is a matter for consideration. With a rifle, the trigger is always arranged below the gun and is pulled toward the gunner. It is usually placed 13½ in. forward

from the butt plate. With the development of machine guns, there was a tendency to move this mechanism to the extreme rear of the gun. With the advent of remote control, however, it is found that more reliable connections can be made by other arrangements, and machine guns are now actuated from top, bottom, or either side. With the development of aircraft turrets, where the receivers of the guns are somewhat behind the gunner, it is becoming increasingly important to rearrange this mechanism to permit actuation from more forward positions.

It has previously been noted that ignition of the cartridge may be caused by several forms of hammers or firing pins. Correspondingly, the energy for the firing pin blow may be obtained from a variety of sources. The selection of the energy source governs the design of the sear mechanism. In some cases the firing pin energy is provided by the motion of a *slide* or other moving gun part. In such case the sear mechanism need only release the slide, the igniting blow being released by the slide later. Another method is to release the spring-loaded firing pin or hammer directly by the sear. Then it is necessary to make provision for this member in the trigger and sear assembly.

When a slide release is used, the trigger mechanism can be operated independently of the position of the slide. When the mechanism contains its own hammer and hammer spring, then it is necessary to include some means of preventing firing except when the action is locked and the parts are in proper position for firing.

7-3 FULL AUTOMATIC MECHANISMS

The simplest kinds of sear mechanisms are those which remain actuated as long as the trigger is held. This kind of mechanism may be used on single-shot weapons (which do not reload automatically) or on automatic weapons to provide full automatic fire. From a practical standpoint,

certain refinements are preferable when used for full automatic fire.

One of the simplest and best known of the sears of this type is that of Mauser, best known in the United States from its use in the U. S. Rifle, Cal. .30, M1903. This mechanism is simple and, therefore, there is little to get out of order; moreover, the sear acts directly at right angles to the firing pin spring so that none of the sear release force is used in working

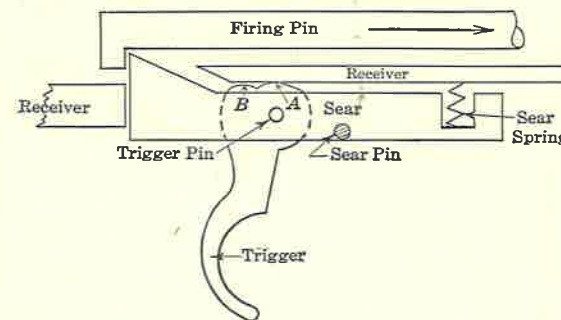

FIG. 32. M1903 Rifle Trigger Mechanism.

against the firing pin spring. As the contact of the sear in the sear notch is above the sear pin, the tendency of the firing pin spring is to lock the mechanism more securely.

As can be seen readily from Figure 32, the sear pivots on a fixed pin and the sear nose is held up against the firing pin by the action of the sear spring. The releasing action is accomplished by a rearward pull on the trigger. The trigger is pinned to the sear and bears against the receiver at one of the two possible contact points *A* or *B*. The geometry of the trigger is such that when no force is exerted on it, the sear spring will hold the point *A* against the receiver. When, however, force is applied to the trigger, the contact is rapidly transferred from *A* to *B*, without any appreciable sear motion. After this transfer, further pull results in camming down the sear, with release of the sear nose from

the sear notch, thus permitting the firing pin to move forward under the influence of its own spring.

The value of having the two contact points *A* and *B* should be noted. If any wear occurs owing to handling of the weapon at any time other than during firing, this wear all occurs at point *A*; no load can be brought on *B* except by actual use of the trigger.

While the type of trigger described is used on some automatic weapons, it suffers from the disadvantage that the

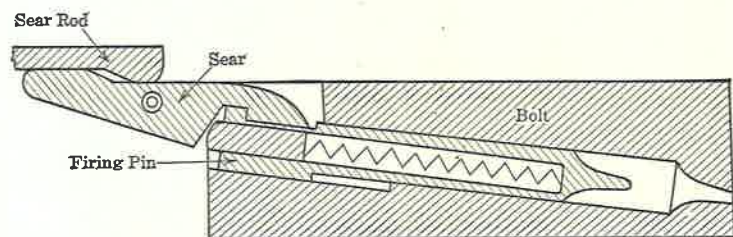

FIG. 33. Fowler Firing Pin Mechanism.

mechanism receives a considerable shock when automatic fire is interrupted. A more satisfactory type is shown in Figure 33 which is simplified from a design patented by E. Fowler (U. S. Patent 1,451,443).

In this mechanism the firing pin is cocked by an element not shown, which moves the firing pin to the left of the bolt, compressing the firing pin spring until the sear latches over the step at the left end of the firing pin. During this operation, the bolt is recoiling toward the left of the mechanism illustrated. On counter-recoil, the bolt moves to the right until the sear rides under the notch of the sear rod and is actuated by it. Control of the firing is obtained by longitudinal movement of the sear rod. If it is moved to the right, the motion of the bolt in the gun is not sufficient to carry the sear into contact with the sear rod and the firing pin will not be released. To initiate firing, the sear rod is drawn to the left until the sear releases the firing pin. Henceforth, firing

will occur at the same place in each cycle until the sear rod is released.

7.4 SEMIAUTOMATIC MECHANISMS

When the action of the gun automatically returns the mechanism to the firing position before the firer is able to release the trigger, a mechanism such as described in the

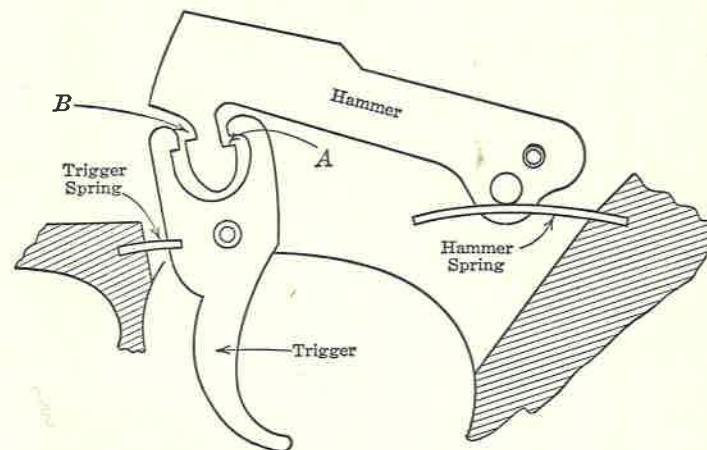

FIG. 34. Semiautomatic Mechanism—Browning.

preceding section will produce continuous fire. To fire only one round at a time, the mechanism must be so designed that the firer is required to release the trigger before *all* the parts can return to their initial positions. An elementary mechanism of this type was patented by J. M. Browning in 1900 (U. S. Patent 659,786). Versions of this mechanism are used in the Garand rifle and the Johnson rifle.

Figure 34 shows the trigger and hammer cocked, ready for release. When the trigger is pulled, it rotates clockwise about the trigger pin and the engagement between the trigger and hammer at *A* is broken. The hammer is then thrown upward by the hammer spring. When some part of the gun moving during the firing cycle forces the hammer down, if the trigger is still held back, engagement will be made at notch *B*. As

pressure is released from the trigger, trigger and hammer springs will cause the hammer to slip out of the notch *B*, but at the same time engagement will again be made at *A*. Now the parts are in their initial positions. If the firer has released the trigger before the hammer returns, engagement will be made directly at *A*. A disadvantage of this simple trigger is that the trigger finger receives a shock each time the hammer strikes a trigger notch. In some modifications, the notch *B* is placed on a movable arm so that when the hammer returns to it, no blow is given to the trigger or the firer's finger.

7.5 CONVERTIBLE MECHANISMS

A convertible trigger mechanism is one which can be used to obtain either semiautomatic or full automatic fire. This action may be secured by providing two separate triggers

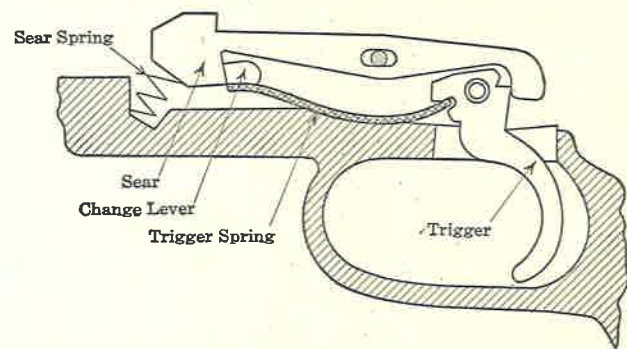

FIG. 35. Convertible Trigger Mechanism (Mendoza).

and using only the one desired; it may be done by pulling a single trigger to two different positions; or by changing the position of one link so that the mechanism will respond differently to the same trigger pull. The third method is the one preferred in this country. The movable link is known as the *change lever*.

Figure 35 shows a mechanism of the change-lever type. In this mechanism the sear pin rests in an elongated hole in the

sear. An action slide engages in the nose at the left end of the sear and normally urges the sear toward the muzzle. If the trigger is released, the rear end of the sear will rest on top of the trigger. When the trigger is pulled, the front end of the sear is lowered from engagement with the slide. As the sear spring is at an angle, the sear is forced upward and rearward, carrying the rear end off the trigger, to the position shown. In this position, the trigger cannot energize it, and the trigger must be released before the strong slide spring, acting through the slide, can again carry it forward. Rearward motion of the sear is limited by the change lever. The shaft of this lever has three faces. In one position the sear can move sufficiently to produce semiautomatic action. In another, the sear cannot move to the rear, it remains on the trigger, and full automatic firing results. In the third position, the front end of the sear cannot be lowered, and the weapon is on *safe*.

CHAPTER EIGHT

CARTRIDGE FEEDS

8.1 INTRODUCTION

While no particular function of a gun can be pointed out as the most important (for the functioning of the whole is dependent upon that of each and all of its parts), the mechanism for feeding the cartridges into the gun is the one which has most often caused difficulty in operation. It is at this point that the gun mechanism connects with other equipment. All other gun functions occur within the mechanism, but the presenting of the new round is often coupled with external conditions over which the gun designer has little or no control. As an example, consider guns installed in aircraft. The ammunition supply is often located some distance from the gun, and each round must be fed through a devious passageway of chutes and channels, all of which exert a friction load upon the gun. The moving ammunition itself exerts an inertia load. Aside from these extra loads, the ammunition must be supplied in a manner compatible with such a devious feed path; the supply medium must be capable of furnishing the requisite number of rounds, etc. Tactical considerations govern the choice of the feed device. When the weapon is to be operated by a single soldier, the ammunition may be fed from small, easily carried and easily replaceable packets. If, on the other hand, the weapon is in a vehicle and will be required to deliver a large amount of continuous fire, such an arrangement would be obviously unsuitable. Consequently, several means of supplying ammunition to the weapon have been developed. The principal types of these are described in the following sections.

8.2 MAGAZINES

A magazine is generally a long, slender spring-loaded container for a few rounds, which can be inserted in the gun when needed. In some firearms, notably magazine rifles, the magazine remains in the gun at all times. However, the distinction here is merely one of attachment of the magazine, the functioning of either type being exactly alike. Some magazines contain only a single row of cartridges, but a double (staggered) row is also common. The use of more rows is complicated by the provision of some device at the mouth of the magazine to feed from any row to a common point in the gun. When not inserted in the gun, the cartridges are retained in the magazine by being pressed between the magazine lips and the floor plate or follower. This force is produced by a

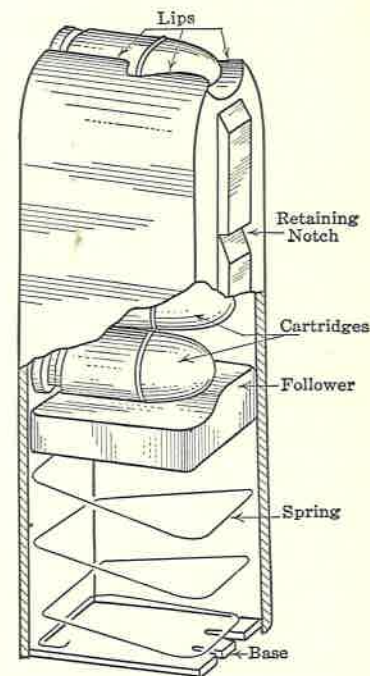

FIG. 36. Magazine.

magazine spring, and, because of the length of the tube, this force varies considerably between the full and empty positions. Being in the class of auxiliary or expendable equipment, magazines are usually made as light and cheaply as possible and, hence, are readily damaged by rough handling. The most vulnerable spot is the mouth. The mouth and lips are precisely formed to deliver the cartridge at the precise point demanded by the gun, and the altering of this point is almost certain to be fatal to continued functioning. To overcome this, some magazines have a

heavy reinforcing over the mouth and a short part of the tube wall.

Attempts have been made to relieve this dependence upon proper magazine lips by designing the mouth as a part of the weapon. Examples may be cited, as the Johnson light machine gun and the Madsen machine gun. In these guns, the cartridge goes from the magazine through a short free space to positioning surfaces in the gun receiver. Hence, the mouth of the magazine may be deformed, but, if cartridges can still pass through it, no harm is done. An objection to this design, however, is that, if for any reason it is desired to remove a partially emptied magazine, usually one or more rounds remain loose in the gun and have to be removed separately.

When it is desired to carry in a magazine more rounds than can be conveniently carried in a straight magazine, a drum magazine may be used. This is an extension of the straight magazine, differing in that the cartridges are carried in helical or spiral rows instead of in a straight or staggered line. The capacities of such magazines do not usually exceed 50 rounds. As 30 rounds, or even 40 rounds, can be carried in straight magazines, the difficulties attending the design and operation of drum magazines usually preclude their use except where special spatial or tactical considerations require them.

8.3 BELTS

To provide longer periods of continuous fire than are possible with separable magazines (which seldom exceed 30 rounds), means have been devised to feed a long belt containing cartridges at close intervals through the gun. These belts are of many forms. They may be either of metal or of woven fabric. If of the latter, they are woven into a continuous series of pockets, from which the gun can extract the rounds in turn. Metallic belts are articulated devices, which can be made so as to remain continuous after removal of the

round or to disintegrate at that time. All belts can be classified in accordance with the way in which the cartridge is removed. It may be pushed directly from the belt into the chamber, or withdrawn to the rear and then, by a reverse

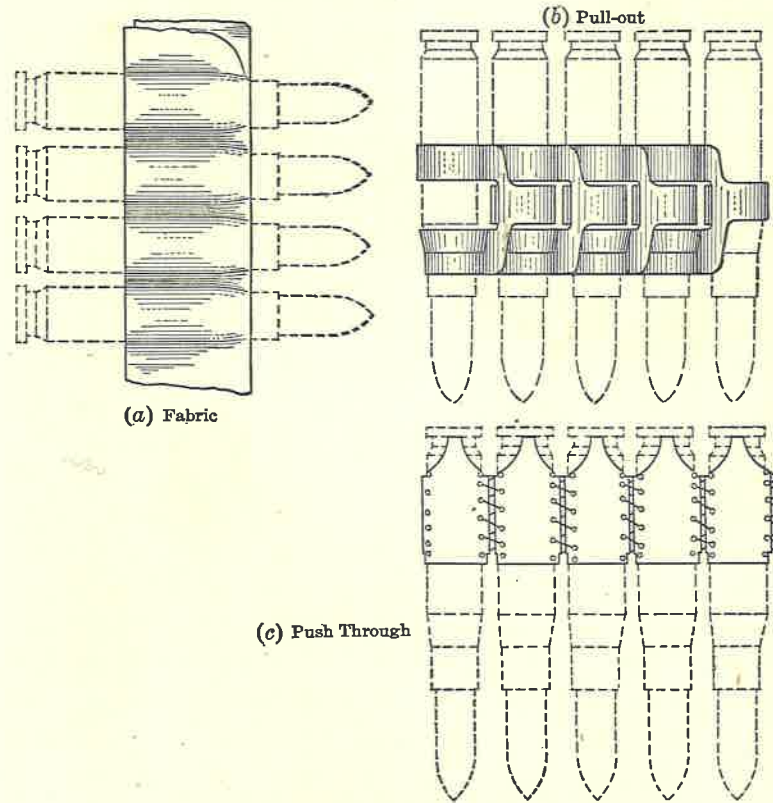

FIG. 37. Feed Belts.

movement, thrust into the chamber. The former method permits much simplification of the feed mechanism.

Independent of the type of belt used, the gun must be provided with a mechanism to advance the belt one space after the firing of each round. This is an additional gun complication over magazine feed, where the magazine spring furnishes the power for this operation.

The successful design of a cartridge belt requires that the cartridges in it be properly located and retained in that position. The retention must be sufficiently positive to prevent accidental removal during handling and feeding, yet permit easy withdrawal of the cartridge by the gun at the proper instant. The provision of a "tail" to engage the extractor groove of the cartridge case has been found to satisfy this requirement well. Flexibility of the belt is a prime requirement where the gun is to be mounted in a confined position or where it may be required to shoot over a large field of fire. The belt must also be formed so that it will pass through feed chutes without catching or binding.

In vehicular installations, it is necessary to remove the empty belt from the immediate neighborhood of the gun after the cartridges are withdrawn from it by the gun. This requires the provision of *link chutes* to lead empty links to a collection location or to discharge them outside the vehicle. The use of these chutes also affects the design in that the empty links must travel freely in the chute without binding or jamming.

Feed belts have been found particularly susceptible to attack by unfavorable climatic conditions. Unless properly treated, fabric belts may shrink or stretch when wet and thus lose their proper hold upon the rounds. They are also liable to attack by vermin in certain regions. As metallic links are usually made of steel, efforts must be made to protect them against rusting and against electrochemical action with the brass cartridge cases.

8.4 STRIPS

Instead of making the belt flexible, it can be made rigid. In this case it is known as a *feed strip*. This is made by taking a flat strip of metal and forming rows of small, curved retaining fingers, whose function is to secure the cartridges. This strip is fed crosswise through the gun as is a flexible belt,

the cartridges being pushed out of it by the bolt in a similar manner.

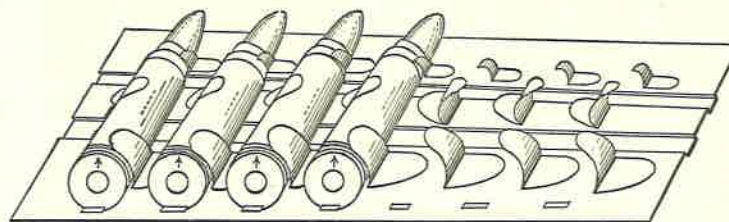

FIG. 38. Feed Strip (Hotchkiss).

A compromise between the flexible belt and the strip is also known. This consists of a series of short strips, each holding only three rounds, hinged together to form a flexible belt.

8.5 CLIPS

Considerable differences of opinion exist as to what is called a *clip* and what is called a *charger*. A clip will be defined here as a holder for a small number of cartridges, so

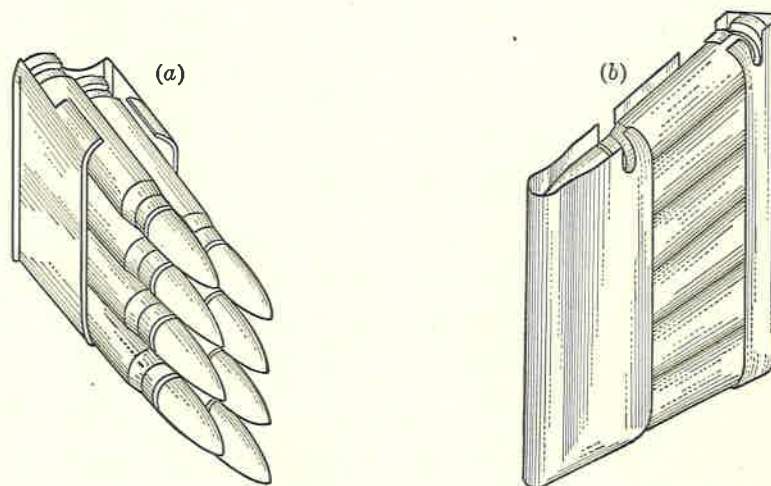

FIG. 39. Cartridge Clips.

designed that the clip and its cartridges are placed together in the magazine of a weapon without removing the cartridges

from the clip. The clip remains in the weapon until all the cartridges are fed and fired from it or until the firer unloads the gun. A clip has no spring of its own, the cartridges being fed out of it by the action of the magazine spring and the bolt of the gun. The capacity of the clip is limited by the space available for it in the magazine of the gun, and may be 8, 10, or more rounds. It should be so designed that either end of the clip can be inserted into the gun, thus rendering it easier to load. A common weakness of clips is that they are difficult to remove from the gun if they are neither completely empty nor full. This is caused by the fact that the clip holds

the cartridges securely only when it is full. If some rounds are removed, the remainder are held together compactly only by another spring which is in the gun. Consequently, if the pressure of this spring is relieved, the rounds will be loose, and unloading will be a task for both hands. Figure 39a shows the clip for the M1 (Garand) rifle and Figure 39b that for the Mannlicher rifle.

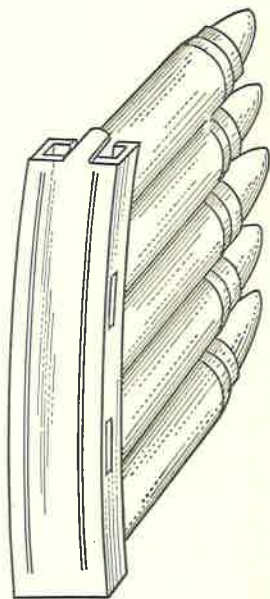

FIG. 40. Cartridge
Charger.

8·6 CHARGERS

In harmony with the definition of a clip given in the previous section, a *charger* is defined as a holder for cartridges which is *not* placed in the gun. Instead, the cartridges from the charger have to be stripped into the magazine. During this operation, some means is usually provided to hold the charger loosely in proper relation to the gun, but from which it may be easily and quickly disengaged when emptied. Chargers usually hold five rounds, this being the number which can

be readily stripped into the gun with one stroke of the thumb. Because of its basic simplicity and efficiency, the type shown in Figure 40, originated by Mauser, is almost universally used.

8·7 HOPPERS

The ability to pile cartridges into a hopper indiscriminately, without regard to points and bases, has long been an idealistic goal. The Japanese have what is known as a hopper feed, but it is really an ingenious variant of a charger feed. In their Nambu light machine gun, the hopper holds five chargers of cartridges in a vertical column. A feed ratchet forces the cartridges in the lowest charger successively into the gun. When this one is emptied, the strong hopper cover spring forces the others downward and pushes the empty charger out through a slot in the bottom of the hopper. This is not a hopper feed in the true sense of the word. A true hopper would permit cartridges to be poured into it indiscriminately, without respect to the orientation of individual cartridges. From this heap of ammunition, the mechanism would be required to select a cartridge and position it properly for feeding into the chamber. No such mechanism is in use at this time. In discussing this type of feed, it may be useful to consider the consumption rate of a gun firing at, say, 600 rpm (10 rps). If a handful of chargers could be thrown in at this high rate, even for short periods of time, each motion of the hand would enter only 10 or 12 cartridges, while, with the same amount of labor, a belt containing 250 rounds could be entered. Of course, the belt must be loaded somewhere, but this function has now been pushed back to the cartridge factories and is no more a concern of the firing soldier than is the assembling of bullet and powder into a cartridge.

CHAPTER NINE

SIGHTS

9.1 INTRODUCTION

The complete mechanism of a gun is quite useless unless some means is provided by which the gunner can determine how to direct his fire so that the projectile will strike the target. In Appendix A it is shown that the projectile does not travel continuously in prolongation of the barrel. The trajectory is curved by gravity, by wind, and by forces introduced by rotation of the projectile. The problem is further complicated by the fact that, when a moving target is to be hit, the gunner must allow for the motion of the target as well as for that of the bullet. To reduce these problems to one capable of instantaneous solution is the task of the sight designer.

The basic problem is that of establishing the proper direction in which to point the gun barrel. This may be solved by aligning two points on the gun with some selected point on or near the target. These points are customarily known as the *front sight* and the *rear sight*. Such sights are called *iron sights* to distinguish them from *glass sights* or *optical sights*, in which an optical system is used to make the aiming point more visible. Either of these sighting means may be constructed so as to be fixed during the firing period, or to be continuously adjustable by someone other than the gunner.

9.2 IRON SIGHTS

These sights are made, as their name implies, of iron (steel) or similar material. The inference in the name is that no

glass is used in their construction. A description of all those in existence is beyond the bounds of possibility. There seems to be a type of front or rear sight designed for each individual shooter. These differences, however, are mainly in the detailed form of the unit.

Except for fixed sights (which are usually found only on pistols, revolvers, and submachine guns) graduations and adjustments are provided on the rear sight so that targets may be engaged at different ranges.¹ It might be assumed

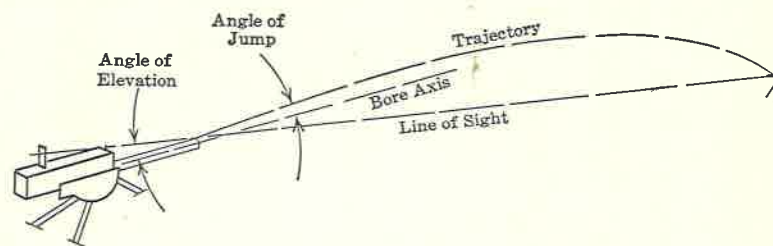

FIG. 41. Effect of Jump on Sights.

that the data for these graduations could be computed directly from the ballistic data of the cartridge. It is found in practice that the construction of the gun and its mount each cause this method to be unreliable. Owing to their flexibility, the initial part of the trajectory is not in prolongation of the bore. The difference between these two directions is *jump* and must be determined by experiment. It is customary, therefore, to fire the gun on its mount in the course of preparing the sight data, in order that jump may be taken into account. (Fig. 41.)

The fact that the trajectory may be curved in the vertical plane by wind or drift has also been mentioned. Because of this, it is desirable to incorporate some adjustment into the sight by which this effect may be compensated. Fortunately,

¹ It is assumed that the firer will adjust his sights to the range and target and will not "aim off" in order to correct the sights by mentally estimating a sight correction.

drift is very small at all common ranges, and it may be assumed to be proportional to the range without serious error. Hence, if the sight is moved at a slight angle to the vertical as it is adjusted for range, the drift correction may be automatically included. Correction for wind is usually made by the gunner. This is done by experience and by learning a set of rules for the cartridge used. Mechanically, a screw is provided so that the rear sight assembly may be moved laterally from the axis of the gun.

9.3 FRONT SIGHTS

With the exception of the ring sight, the front sight is made as an approximation to a mathematical point. It is essentially a spot which can be readily discerned by the firer and so constructed that it may be seen against any background.

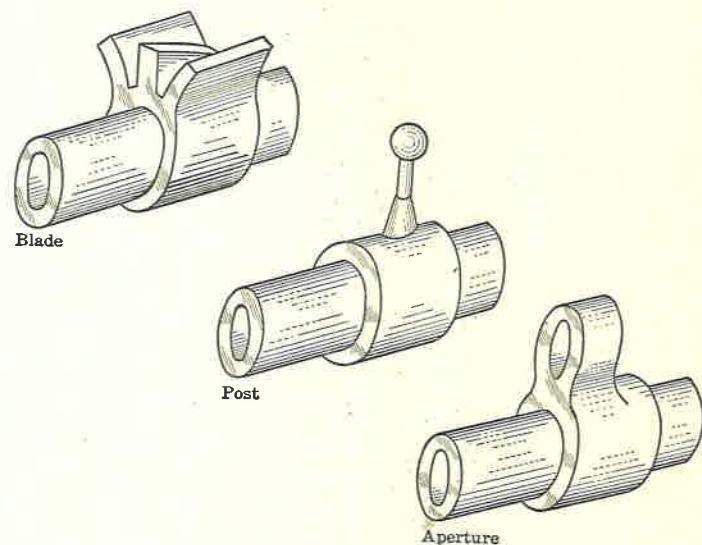

FIG. 42. Front Sights.

Figure 42 shows three types of front sights: *blade*, *post*, and *aperture*. With the first type it is customary to use the top surface as the aiming point, while the other two are centered

upon the target. The blade sight is shown with guard wings. These wings protect the sight against accidental damage.

The ring sight is used against moving targets, and was the forerunner of computing sights. Its use requires some mental calculation by the gunner, and it cannot be used effectively with rapidly moving targets. The time of flight of a projectile to any given range X is t . If the target is moving in a straight line with a constant velocity v , then in that same time interval t , it will cover a distance vt . The problem is to quickly determine the angle whose tangent is vt/X , known as the *lead*. This relation imposes no limits on the direction of the target other than it must remain constant and be approximately on a crossing course.¹ Thus, at the instant of firing, the airplane, for example, may be at any point on the circumference of a circle whose center is the point of impact. It may further be assumed that the airplane will fly a more or less level course. This reduces the locus of targets to a circle in the horizontal plane. For a given range, and a given target speed, it is possible to provide a circular horizontal ring for a front sight, and if the target is always kept on the periphery in such a way that it appears to be heading for the center of the ring, the proper allowance will be made for its advance during the bullet's flight. The preceding statement requires that the range and the target speed be as assumed and that the ring remain horizontal for all elevations of the gun. Although a simple mechanical linkage could be provided to maintain the ring in a horizontal position, it is customary to assume an average angle of elevation and design an elliptical sight which remains fixed to the gun casing. The assumptions concerning range and target speed cannot be met with the same ease, however, for the range and speed of the target cannot be fixed beforehand. Again, a compro-

¹ For other courses the approximation becomes less exact unless the crossing component of the target speed is used.

mise solution can be made, or two or more rings may be provided to handle a range of combat situations. It is because of the number of assumptions made that this sight is unsatisfactory. Whenever the target is not located according to

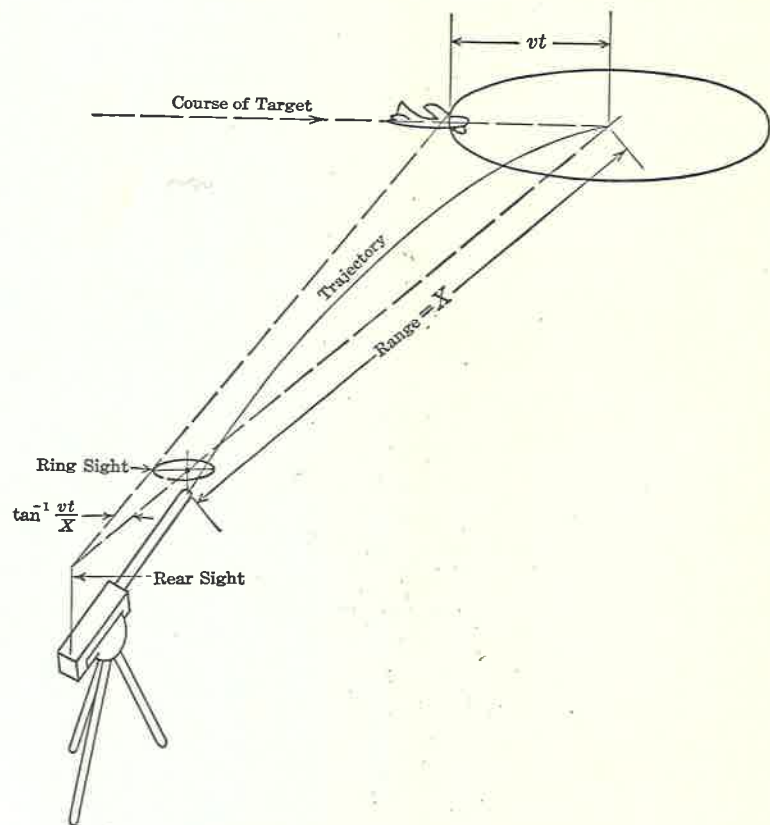

FIG. 43. Principle of Ring Sight.

assumption, the gunner must make a mental allowance and hold the sight off. The end result is that this type of sight often becomes more of a hindrance than a help, and greatest reliance must be placed upon fire control by observation of tracer bullets if more complicated sights are not to be used.

9.4 REAR SIGHT APERTURES

As the rear sight is the one which contains the adjustments, it will be discussed under two headings, (a) the form of the sight itself and (b) the method of making adjustments.

It has been stated that the gunner aligns the front sight with the target; he must look over or through the rear sight in order to see the front one. The earliest rear sights consisted of a blade in which was a notch. When a certain amount of the front sight was seen above the notch, the sights were properly aligned with the gunner's eye. This form is still in use in many guns and is often incorporated in more refined sights as an always ready *battle sight*.

As sighting through an open notch is not entirely satisfactory, owing to the difficulty in determining the proper amount of front sight to advance above the notch, the *peep sight* is made by covering the upper side of the notch to form a round hole. This arrangement permits the gunner to center the front sight in the hole of the rear sight. The rear sight is placed so far from the eye that it is possible to form a distinct image of it upon the retina. Hence, there is a tendency for the eye to try to focus upon three objects at the same time: the rear sight, the front sight, and the target. Much of this confusion can be eliminated by practice so that the eye looks *through* the rear sight and *at* the front sight and target. As the front sight will usually be about 3 ft from the eye, both the front sight and the target will be in approximate focus for the same contraction of the optic lens.

Consideration should be given to the size of the hole in the rear sight. Two considerations are involved—illumination and definition. The former is secured by the use of a large hole, the latter by a small one. The question of obtaining accuracy by the use of a small hole does not appear to be of major importance because the gunner will unconsciously center his eye behind this hole in an effort to best see the front sight. Prime consideration should be given to securing

sufficient light through the sight in order to see the front sight and the target. Definition should be secured through corrective spectacles rather than by a correction built into the gun. The aperture need never be greater than the human pupil, which may enlarge to 0.20 to 0.30 in. at times. These sizes, however, are much larger than those used for sights, which are in the order of 0.08 in.

The third type, the *aperture sight*, differs from the peep sight not in structure but in location. This sight is placed as near to the eye as possible (allowance being made for the recoil of the weapon), and no effort is made by the gunner to align the rear sight. The action of the gunner in using this type of sight is entirely that of looking *through* it. It is so near the eye that no attempt can be made to look *at* it. An advantage of this sight is that it does not restrict the field of view as does the peep sight, which naturally requires a surrounding body of metal to contain the hole.

9.5 REAR SIGHT STRUCTURES

When differentiated by structure, rear sights may be classed as *fixed*, *folding leaf*, or *ramp sights*.

The fixed sight, as its name implies, has no adjustments, the aperture or notch being placed on some projecting portion of the weapon (Fig. 44).

The folding leaf sight is used where the sight elevation is so high as to make it impracticable to leave the sight projecting permanently at this distance from the body of the gun. The *leaf* is held in either the raised or lowered position by a flat spring and serves as a standard upon which is moved the *slide* containing the aperture.

This slide may be moved by hand and clamped by a thumb screw or it may be operated by a vertical screw operating in one side of the leaf. The sight setting is indicated by the use of range graduations on the leaf. These graduations can be

in linear units for directing aiming or in angular units for use when indirect fire from a fixed mount is contemplated. Sights of this type are called *tangent sights*, as the sight leaf is tangent to an arc of an imaginary circle whose radius is the

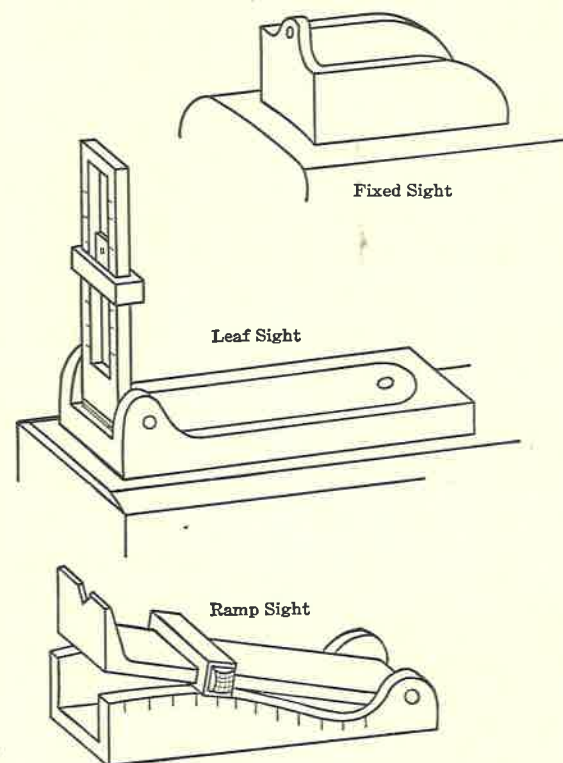

FIG. 44. Rear Sights.

distance between the two sights (*sight radius*). Correspondingly, the elevation markings on the leaf are computed as the tangents of the corresponding angles of elevation.

Where only small elevations are required and particularly where a wider spacing of the graduations is preferred, the *ramp sight* may be used. Whereas in the leaf sight the leaf is always raised to the same position and the position of the aperture on the leaf is varied, in the ramp sight the aperture

remains fixed at the end of the leaf while the leaf itself is raised to various positions. The desired position may be chosen by moving a slider on the leaf along the surface of a curved ramp. The curvature of the ramp and the spacing of the graduations are computed to provide the proper sight elevations. The leaf is held in contact with the ramp by means of a flat spring.

9.6 COMPUTING SIGHTS

Reference has been made to ring sights in Section 9.3. A ring sight is at all times available for a limited preselected number of sighting conditions. To make a sight which will be useful in a larger number of situations, the sight can be reduced to one setting, but this setting made adjustable to conform to the individual requirement of the moment.

If this adjustment is made mechanically by a linkage controlled by the position and the motion of the gun, such a sight is known as a computing sight. Unfortunately, in a text of this size, it is not possible to dwell on these sights as they are of very limited interest. Many variables must be considered, and the mechanism required for a sufficiently accurate solution rapidly becomes extremely complex. Some of the factors to be taken into consideration in the design of computing sights are:

- (a) Range.
- (b) Elevation.
- (c) Direction of motion of the target.
- (d) Velocity of the target.

These and more factors are required in order to predict the position which the target will occupy when the projectile reaches it. For short ranges, the simple equations given in Section 9.3 are not suitable for accurate prediction. This is principally because the target is seldom on a truly crossing course and because at short ranges the range to the predicted

position is much different from that to the observed position and requires corrective recomputation.

9.7 OPTICAL SIGHTS

These sights, as distinguished from iron sights, consist of simple telescopic optical systems. Rifles intended for sniping are provided with a straight line telescope usually containing optical elements as shown in Figure 45. These telescopes are of modest power, usually $2\times$ to $4\times$, and contain only sufficient adjustments to zero the scope to the rifle. The optical

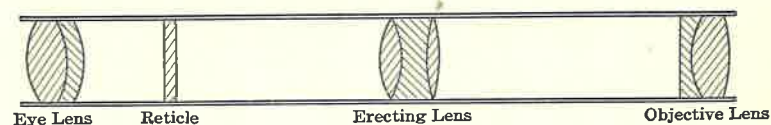

FIG. 45. Telescopic Sight Elements.

elements are the objective, erecting system, reticle, and eye-piece. A peculiarity of telescopes for use on rifles is that the eye relief should be at least 4 in. so that recoil of the weapon shall not force the telescope against the face of the firer. Where it is not possible to obtain this much eye relief, a rubber cup can be provided to cushion the blow. A telescope to be mounted on a firearm must itself be able to withstand the effect of the recoil. All optical elements must be rigidly mounted and supported. The use of single simple optical elements is to be preferred to more complex ones. For example, a single erecting prism will remain in adjustment with more certainty than will a set of cemented erecting lenses.

The reticle is provided with several etched marks corresponding to various ranges, and aiming is accomplished in the usual manner by aligning the target with the proper range graduation. It is also possible to provide a metal wire as an aiming post, to be used in much the same way as a front sight. As with all high-class optical work, a rifle telescope

should be of sealed construction in order to prevent deterioration of the enclosed elements by atmospheric influences.

For machine gun firing, where long ranges may be encountered, the long, straight form of telescope is no longer suitable, a *dial sight* being used. The dial sight consists essentially of a short offset telescope with which precise measurements can be made. It is from the dials of the measuring screws that this type of sight receives its name. As in other sights, a reticle may be provided, or a movable index may be used to indicate the desired range and deflection settings. Dial sights are commonly provided with a level vial so that they may be used to aim the gun for indirect fire.

BIBLIOGRAPHY

- HARDY, A. C., and PERRIN, F. H., *The Principles of Optics*, New York, McGraw-Hill Book Co., Inc., 1932.
- Sonderheft Flugabwehr*, Ver. deut. Ing., Berlin, 1938. (This booklet contains reprints of various articles on antiaircraft fire control items which appeared in the *V.D.I. Zeitschrift* the previous year.)
- WANINGER, C., and FÜSGEN, P., *Das Richtung der Geschütze*, Ver. deut. Ing., Berlin, 1938.
- WHELEN, TOWNSEND, *Telescopic Rifle Sights*, Plantersville, S. C., Samworth, 1944.

CHAPTER TEN

DESIGN PROBLEMS

10.1 INTRODUCTION

This chapter deals with presently unsolved problems of gun design. It must not be assumed, once a gun is designed and a functioning model made, that it will perform in a satisfactory manner under all conditions, for all time. The ideal, of course, is to obtain such a weapon, and progress toward that end is being made. There are many items, some of them design faults and some of them natural results of the physicochemical processes employed to operate the gun, which cause guns to malfunction. This chapter lists these items and explains their principal causes and associated phenomena.

10.2 BORE EROSION

Erosion is a main source of difficulty with automatic weapons. With automatic firing, the bore soon enlarges and a loss of accuracy results. Erosion is recognized by changes in the dimensions of the gun bore. Three changes may usually be found in a worn gun:

- (a) Muzzle enlargement.
- (b) Coppering or metal fouling.
- (c) Breech erosion.

Of these, only the last is truly erosion. Brief notice will be taken, however, of the other two as they are all associated phenomena and progress together.

Muzzle enlargement is probably due to lateral forces

exerted by the bullet as it leaves the bore as well as to gas wash caused by gases leaking past the bullet. There is usually a sudden enlargement just at the muzzle and a somewhat smaller enlargement progressing throughout the first third of the barrel length.

The center third of the barrel usually exhibits very little wear. This part of the barrel is subjected to medium temperatures and pressures and, being relatively thick in diameter and near the gun body, does not undergo the large vibrations which persist at the muzzle. Consequently, little mechanical action would be expected. When the bullet jacket or rotating band consists of an extremely soft metal, some of it is worn off and adheres to the surface of the bore. By this process, the bore diameter may actually become smaller after firing than before. In artillery, where soft copper rotating bands are used, this is called "coppering." When cupro-nickel bullet jackets were used in U. S. Army rifles and machine guns, a large amount of this jacket material accumulated in the bore. This accumulation was generally termed *metal fouling* to distinguish it from the corrosion products caused by the powder and primer. It could not be removed by cleaning with brush and water, and the issue of ammonia for its removal was necessary. With the adoption of hard-drawn gilding metal jackets, this trouble has been greatly reduced.

The breech end of the barrel is the part most affected by continued firing. At this end occur the greatest temperatures and pressures, and here also occurs the initial gas leakage before the projectile is firmly seated in the rifling grooves.

Perhaps no subject has aroused more discussion than erosion. Numerous theories have been advanced, and some support has been found for nearly all of them. The fact that erosion occurs in repeated steps of extremely short duration, under conditions of high temperature and pressure, has made

it extremely difficult to distinguish and separate the various factors entering into the process.

The principal conjectures bearing upon the processes of erosion are recounted below.

(a) *Mechanical.* When the powder pressure is generated, it causes the bore to expand. As this force is applied suddenly, it is quite probable that its effect on the metal of the surface and immediately underneath is much larger than calculated. Hence, this metal will be overstrained and will suffer plastic deformation. This overstrain will cause the formation of minute axial ridges which will readily crack when they are cooled by flow of heat to adjacent metal. The resultant destruction of these cracked ridges will cause the formation of the characteristic axial channels.

(b) *Thermal.* The high flame temperature of modern powders causes the bore surface to be raised to temperatures above the softening point of the metal. This softened metal is then worn away by abrasion and chemical action.

(c) *Chemical.* The combustion of the powder releases carbon monoxide, hydrogen, and nitrogen, as well as other more stable components. These readily combine with the steel at the high existing temperatures and cause a surface hardening, similar to carburizing or nitriding. These cases are lacking in ductility and can be flaked off by the action of succeeding shots.

The general processes of erosion have been well summed up by Gray¹ as follows:

Apparently erosion follows a course which includes, first, a hardening of the skin of the bore, followed by a cracking, longitudinally, and transversely. These cracks are enlarged by the effect of gas at high velocity, temperature, and pressure, and quite probably by bombardment of extremely hot particles of burning powder and primer. Some removal of metal is considered to be caused by abrasion of the bullet.

¹ Reprinted by permission from "Erosion in Machine Gun Barrels," by J. C. Gray, *Army Ordnance* XV, p. 34, 1934, published by the Army Ordnance Association.

It appears that the principal change in the metal is due to its softening at elevated temperatures. It can be reduced, therefore, by keeping the bore temperature low. This has been attempted by placing fins about the barrel to increase the radiation surface. Unfortunately this does not increase the heat radiation to an appreciable extent because of the extremely high rate at which heat is added to the barrel. The provision of a water jacket has been tried for the same purpose. Contrary to the usual expectation, the exterior temperature of a water-cooled barrel does rise above the boiling point. When heat is emitted from the barrel at a rate greater than that at which it is removed by the circulating water, the water near the jacket boils, and higher temperatures can exist at this surface. It has been shown in Section 2.6 that surface cooling is likely to have little effect, owing to the large temperature differentials needed to drive the heat through the barrel metal at the rate at which it is received.

If the heat cannot be removed from the barrel once it is absorbed, relief may be secured by preventing the heat from entering. The value of chromium plating in reducing erosion may be due in large part to the high reflective power of the metal. Failing in this, effort must be directed toward improving the metal from which the barrel is formed so that it will resist the destructive mechanical effects of the bullets and gases when it has become heated. The property of *red hardness* is the one sought. For this reason, barrels are made of selected alloy steels, 4150 and 4650 being commonly used. As the erosive process seems to proceed largely by a process of abrasion, the barrel should be initially made hard. This has its limits, however, as a hard barrel steel cannot be worked to turn, drill, and rifle it.

The quantity of heat produced within the bore can be controlled by the selection of the powder. For instance, double-base powders burn with a higher temperature than single-base powders and cause a barrel to erode one and a half or

two times as fast as a single-base powder giving the same bullet energy.

10.3 GAS PORT EROSION

It has been observed that, when a gun barrel has a gas port, the forward edge of the gas port will wash away. This is due to the impact of the rapidly flowing gases and powder particles. There is little that can be done to overcome this destruction. The gas port can be formed in a separate, replaceable plug which is screwed into the barrel wall. This method has been in use since the days of weapons fired by flame through a touch-hole. Further, the design of the gas passage can be such that the entrance from the gun bore is not the most restricted part of the gas passage. Hence, the quantity of gas flowing will not be affected by variations at the entrance caused by erosion.

10.4 CORROSION

The subject of corrosion, as it affects guns, does not differ from the concepts given in any general metallurgical course. There are two attacking agents:

- (a) Atmospheric moisture and saline agents.
- (b) Chemical agents produced by the combustion of the propellant and primer.

Action taken against the first type of corrosion consists in providing a corrosion-resistant surface finish. *Blueing* and *browning* are traditional finishes for firearms. They are produced by the repeated application of corrosive agents to the metal until a rust coating of the desired thickness is obtained. Currently, variations of the commercial Parkerizing process seem to be the most successful. This process provides a phosphate coating, closely adherent to the parent metal, which is resistant to atmospheric corrosion, salt water corrosion, and mechanical abrasion. The effectiveness of this type

of coating is greatly improved by dipping the object in a light oil after the surface treatment. This oil treatment directly incorporates a moisture-repellant element into the protective surface.

The previously described finishes are intended for permanent protection. Surface protections also are needed during shipment. The traditional method in all industries has been to coat the metals with a heavy grease and to wrap or box them so that it will not be wiped off in transit. The use of Cosmolene or Rust Preventive No. 2 by the U. S. Army in this connection is well known. Such a compound must be sufficiently stable to resist temperatures of, say, 160 F, which might be encountered during transportation, but must also be capable of being removed without undue difficulty. The possible presence of moisture within the protective coating must not be overlooked. Often the formation of rust underneath the slush has been a source of consternation, but its cause could probably be traced to contaminated compound.

Recently, the use of a dehydrator for protection during short periods has been adopted. The principle involved is that of absorbing any free moisture which might collect around the protected object. In this case, a partially ventilated container holding the active material is placed within the package near the gun, which has been thoroughly cleaned and dried, and the entire package is sealed within an outer container. A rigid container is used externally to protect the sealed unit. By this method, it is possible to clean and lubricate machine guns at the factory, and ship them without a slushing compound so that they may be directly assembled into aircraft or other vehicles without disassembly for cleaning and consequent reassembly and readjustment.

One other form of gun barrel corrosion remains to be discussed. This is the destruction of the bore caused by the residues left after firing. It is seen that the bore of the gun is

traversed by three substances—the bullet, the propellant (including its gases), and products released by the primer. All of these leave residues after their passage.

The deposit left by the bullet has already been discussed. As a metal fouling, it is chemically inert and inactive. However, it may cover and prevent the removal of more active residues, so for these reasons the bore must be kept free of it.

The propellant powder is burned into several compounds, whose nature depends upon the type of powder used. The old gunpowder mixture of sulfur, saltpetre, and charcoal produces, among other compounds, potassium sulfide. This is formed as a solid which soon fills the grooves of the rifling, where it not only closes the bore, but also serves as a hiding place for moisture and soon causes rusting of the barrel.

Modern nitrocellulose powders produce only gaseous end products such as carbon dioxide, carbon monoxide, hydrogen, nitrogen, ammonia, and water vapor and hence do not foul the bore nor cause it to rust. The small amount of water vapor formed by each round is kept in the gaseous state by the heat of the barrel and so does not collect.

The third item, the primer product, is of more interest. Much has been said and written of corrosive and non-corrosive primers. Many commercial types of primers produce end products which are not harmful. There are other types, principally those based upon potassium chlorate, whose end products are definitely undesirable. This particular chemical compound reduces to potassium chloride, a substance akin to sodium chloride (table salt) which has a well-known power of absorbing moisture. This salt in a gun bore therefore acts as a nucleus which retains water and initiates rusting. Often primer fouling remains covered by metal fouling, and requires that the latter be removed by chemical or mechanical means before the primer fouling may be washed out. It is because potassium chloride has such an affinity for

moisture that it can be washed out with water, whereas cleaning with oil will not touch it.

10.5 LUBRICATION

The purpose of lubrication is to reduce the friction between the moving parts of a weapon. The problem is to maintain this function under all conditions.

It need not be stated that the lubricants used are oils. Under limited conditions where heavy loads exist, greases may be used. Generally, this practice is to be avoided wherever possible because at low temperatures the viscosity becomes high and the lubricant hardens. Corresponding care must be taken that the lubricant selected does not become dangerously thin at high temperatures. This end is readily achieved, however, as ambient temperatures rarely exceed 150 F under any conditions.

Under modern chemical treatment, oils are available which are chemically stable and chemically neutral. Hence, gumming due to decomposition and corrosion caused by free acids may be avoided.

The design of a mechanism must not require an excessive amount of lubricant. Free oil is not only unattractive, but it contaminates everything it touches, and serves as a resting place for metallic chips, sand, dust, and other free wind-blown objects. These sooner or later work into the mechanism and clog it, requiring disassembly and cleaning.

10.6 CLIMATIC EXPANSION

Within the continental limits of the United States, temperatures at ground level have been recorded as low as 50 F below zero and as high as 120 F above. Temperatures as low as -75 F have been encountered in the polar regions and at high altitudes. Indeed, at very high altitudes the temperature is relatively independent of time of year and time of day, so that temperatures of this order are likely to be en-

countered at all times. Owing to heat absorption, the temperature of metal of guns in sunlight will often exceed that of the air, so that operating temperatures above the 120 F noted may be encountered. Owing to the heat produced in the barrel, temperatures of some parts of the mechanism are raised even above this. In some cases drawing of temper, softening of springs, charring of wood, and blistering of paint have been observed. These phenomena indicate local temperatures above 400 F.

When a gun which has been built at approximately 70 F is taken to such extreme temperatures, there will occur expansion or contraction of the metal. In the case of unsymmetrical components, this will cause distortion and binding of the action. Where unlike materials are used, clearances will open or close and fits will change. The remedy for these effects is careful designing, skill in the choice of materials, and allowance of liberal working clearances wherever possible.

10.7 DIRT STOPPAGES

The stoppage of a weapon caused by the presence of foreign matter has been mentioned in Section 10.5. The principal foreign materials encountered in service are water, sand, and mud. The last, of course, is a special form of the other two.

Rain not only throws up dirt from the nearby ground, but enters the mechanism, causing rust and washing away the lubricant. The action of sand is detrimental in that the sand scores the working parts, causing them to wear rapidly. Dust is often packed into corners where it builds up and prevents full travel. In some cases, individual grains are large enough to fill clearance spaces and directly cause stoppages by binding. The action of mud is similar to that of the other two elements.

The harmful actions of any of these may be prevented by closing up the gun so that they cannot enter. This can be

done by providing slides or covers so that, except when firing, the gun is a closed assembly. Where a gun is designed exclusively for use in aircraft and not exposed to such contamination, these devices are not needed and an open construction can be used, thus keeping the weight down. Further, if the mechanism is one which does not require close fits and small clearances for successful operation, it is best built with ample play between the parts. This will not only facilitate manufacture, but will provide spaces in which foreign matter may gather without jamming the mechanism.

10.8 MALFUNCTIONS

A malfunction occurs whenever a weapon acts in a manner not predicted by its designer. Some of these malfunctions are due to external causes; these have already been discussed in this chapter. Some are due to breakages or excessive wear of the parts; these will be discussed in the next section. The remaining causes consist of those which are due to lack of refinement of the design. These may be classed as:

- (a) Failure to feed cartridge from feed device.
- (b) Failure to chamber cartridge.
- (c) Failure to lock action (or close completely).
- (d) Failure to ignite cartridge.
- (e) Failure to fully operate action.
- (f) Failure to extract cartridge case from chamber.
- (g) Failure to eject cartridge case from gun.

Obviously, this list must be tailored to fit each individual gun mechanism, and a detailed discussion cannot be given except for each mechanism. The following treatment, therefore, is in the nature of an outline of reasoning to be followed in the effort to locate the cause of the failure.

The first step in investigating a malfunction is to record the exact position of the parts of the gun, the position of the cartridge, and whether the parts were in normal relation to

each other. Following this, the parts may be moved and examined for markings. Usually the cartridge will be deformed or scarred in some way. Gouges or scars on the operating parts will give indications of contact points. Sometimes, when such evidence is not to be found and a persistent malfunction cannot be tracked down, it may be helpful to apply a thin layer of Prussian blue or white lead to one of the suspected parts or to a cartridge in order that a more visible mark will be made.

Having located the portions of the gun involved in the malfunction, it should be established that these components, as well as the cartridge, conform to the design laid down. From that point the analysis will vary. An interference may be discovered; on the other hand, it may be found that there is not complete definition of motion among the associated parts. The action of a gun when firing is greatly different than when operated slowly by hand because of inertia forces.

In deducing the cause from the position of the malfunctioned parts as found, care must be taken not to confuse cause and effect.

In one actual case, cartridges were repeatedly found stubbed, with a marked flat on the point of the bullet where they had come to rest against the breech face of the barrel just below the chamber. Obviously, the cartridge had been directed too low and had missed the chamber. Further investigation disclosed a fine mark on the upper side of the bullet, where it had been struck a grazing blow. It was afterwards confirmed that the cartridge had been fed too *high* and, striking at the top of the housing, had been thrown down so that it came to rest below the chamber.

The complete correction of malfunctions can be made only by careful and thorough analysis. No piece of evidence, however small, should be neglected; no investigative aid is too unimportant to be used.

Where deduction fails to disclose faults, recourse must be had to instrumental evidence. According to the old saw, "Seeing is believing." Some methods used to secure visual records are discussed in the following chapter.

10·9 BREAKAGES

Broken parts are obviously ones which are too weak to carry the load assigned to them. As a broken part will usually cause a stoppage of the gun, the procedure for investigating a malfunction should be followed. The caution to distinguish between cause and effect must be carefully applied. Merely increasing the size of a part, although contributing to its strength, does not alleviate the cause of its breaking. A check should be made of the parts which contact the breaking part to see if the motion imparted to it is not smooth, or is applied in an inefficient manner.

If the load upon the part cannot be reduced (and many designers seem reluctant to accept minor revisions of their designs to provide for smoother loading), then recourse must be had to the time-honored methods of strengthening the part, among which are:

- (a) Increasing dimensions and fillets.
- (b) Changing metal composition.
- (c) Changing heat treatment and surface hardness.
- (d) Changing surface finish.
- (e) Reducing manufacturing tolerances.

In this connection, too much emphasis cannot be placed upon the study of inertia effects and inertia forces and the effects of changes in part contour in causing stress concentrations.

10·10 SPRINGS

While all types of springs are used in guns, the helical compression spring is most common. This type of spring is

avored because, if it breaks, it usually continues to function after a fashion, although being shorter than desired by the pitch of one coil.

The life of springs in guns is limited by several factors. First, the proximity of the gun barrel, in which the propellant is burned, serves to heat the spring and to draw its temper. No spring should ever be wound about the barrel. Second, as springs are not perfectly elastic, after several cycles, hysteresis of the spring itself has developed heat and raised the temperature of the spring. To add to this difficulty, springs are often placed in deep, narrow wells where they cannot diffuse their heat by radiation or convection. Continued operation under these conditions will also result in drawn springs.

The greatest enemy of spring life is spring surge. When a load is applied at a rate comparable to the rate of response of the spring, a large portion of the load is taken by the first few coils and these compress solid, causing a severe wave to travel back and forth along the spring. Thus, although the static calculations of the spring show that it does not go solid, the effect of the surge is to compress it solid. Therefore, it is a safe course in designing springs of this type for guns to design them so that if compressed solid, they will not be overstressed. The alternative to this step is to incorporate into the spring some means to prevent or to dampen out the surges. As, however, these means operate by the absorption of energy, they would be expected to increase the hysteresis of the spring as the cost of extending its life.

At these high rates of loading encountered, the action of the spring differs greatly from that commonly assumed. For example, if the spring is very long, its rate of relaxation will be very slow and the moving member may bounce free of it and derive no energy from the spring on its expanding stroke. In such case, the designer is often required to choose between designing for short spring stroke and high impact stresses or long stroke and slowness of response. This may

be partially overcome by the use of Belleville or other types of springs which operate more directly and have a quicker response.

BIBLIOGRAPHY

- CHARBONNIER, P., "La Veine Gazeuse," *Mem. artillerie française*, Vol. 1, p. 1001, 1922.
- CRANZ, C., *Lehrbuch der Ballistik*, Band II (Innere Ballistik), Leipzig, Springer, 1926.
- GRAY, J. C., "Erosion in Machine Gun Barrels," Washington, D. C., *Army Ordnance*, Vol. XV, p. 34, 1934.
- SCHWINNING, W., "Metals for Gun Tubes," *Mem. artillerie française*, Vol. 16, p. 495, 1937.
- SCHWINNING, W., "Researches on the Wear of Gun Tubes," *Mem. artillerie française*, Vol. 16, p. 441, 1937.
- WEAVER, E. M., *Military Explosives*, New York, John Wiley & Sons, Inc., 1917.
- YOUNG, J. F., *Materials and Processes*, New York, John Wiley & Sons, Inc., 1944.

CHAPTER ELEVEN

THE TESTING OF WEAPONS

11·1 INTRODUCTION

At the time of this writing a great change is being made in the testing of weapons. This has come about largely through the development and application of electrical methods of measurement. Earlier methods, while simpler in construction, and often productive of more rapid approximate results, were limited by inertia and spatial requirements. The use of electronic devices now permits recording of transient data which were formerly incapable of analysis.

Because many of the earlier methods are still in use and are satisfactory for rough or general work, they are described, as are also new methods.

11·2 PRESSURE—MEASUREMENT BY COPPERS

Measurement of the pressure within a gun barrel was first attempted by measuring the work which the pressure would do on a small, deformable body. In the middle of the last century Rodman allowed the pressure to drive a knife into a soft lead block, and compared the varying depths of cuts to estimate the various pressures.

This method was followed by the crusher method, wherein a soft crusher cylinder, between two flat parallel plates, is deformed by the pressure. Such a gage is shown in Figure 46. A yoke is shrunk on a barrel close to the breech, and a hole is drilled through the yoke and barrel directly into the chamber. This hole is usually located near the middle of the chamber although there is no fixed rule for its position. Within this

hole there is placed an obturating cup and a piston. The upper end of the piston is provided with an enlarged surface to support the crusher cylinder. The cylinder is held on the piston by the anvil, which is screwed down tightly by hand.

The crushers used for this work are of soft annealed copper. The length must be controlled closely (0.002 in.) and the end

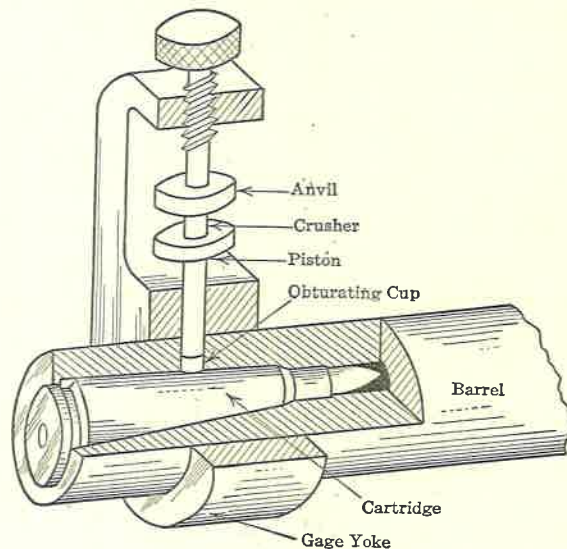

FIG. 46. Crusher Pressure Gage.

surfaces must be parallel and smooth. In America, cylinders 0.2255 in. in diameter and 0.4000 in. long are used, whereas in Europe cylinders 8 mm in diameter by 13 mm long are used. For the measurement of extremely low pressures it is customary to use larger lead cylinders. The use of copper spheres is also being advocated. Spheres possess the great advantage of being more practical for quantity production than the cylinders.

The length of the crusher is measured before firing, and the change in length due to the impact of the powder gases after firing is also recorded. To convert this change of length into pressure, it is necessary to refer to the *Tarage table* provided

for each lot of coppers. The Tarage table is prepared by compressing cylinders selected for uniformity in a compression testing machine and noting the final lengths after the application of various loads.

It will immediately be noted that this method is open to several criticisms. First, the load used in preparing the Tarage table is *static*, whereas the loading in the gun is *dynamic*. Second, as the crusher deforms plastically, the length of time during which the gas pressure acts will vary the reading. Third, as the cylinder is deformed an appreciable amount the inertia of the moving piston must be taken into account, as this will cause continued compression, owing to dynamic overshoot after the gases have ceased to act. This effect can be decreased by pre-compressing the coppers to a load slightly less than expected in the gun. The Tarage table for cylinders so pre-compressed will differ from the one for uncompressed cylinders.

Pressures measured by a crusher gage and referred to a static Tarage table may be as much as 30 per cent below the true values. This error varies with different guns, powders, and temperatures. Because of this variance, this method is best used when many comparative readings, using extremely simple equipment, are required for highly repetitive work.

11.3 PRESSURE—MEASUREMENT ELECTRICALLY

The crusher method of measuring pressures has been used for many years in spite of the development of new and improved methods because it possesses two advantages—it is simple to operate and can give pressure readings without delay. The other methods available require electronic equipment and processing of the record. Although this latter difficulty is being overcome, the equipment used is still of laboratory type.

By the use of electrical methods, it is possible to produce accurate pressure records which show not only the maximum

pressure, but which also show the course of the gas pressure at any instant. For this purpose, an installation similar to that for a radial crusher gage is made, differing in that the radial hole is larger and a stack of several quartz discs is used instead of the copper cylinder. Each disc, when compressed, produces an electrical potential. This piezoelectric potential is increased in magnitude by building a stack of crystals and adding their charges to secure sufficient potential to operate an electric circuit. After amplification and the filtering of extraneous impulses, the resulting signal is fed to the control plates of a cathode ray tube or oscilloscope. The deflection of the electron stream by this circuit may be recorded on a moving film, or, if a sweep circuit is added, the change in the pressure can be recorded directly as a function of time on a stationary film.

In addition to the use of piezoelectric gages, resistance gages may also be used. This method depends upon the change of resistance of a wire when deformed mechanically. For example, let a thin hollow cylinder be wound circumferentially with a fine wire. If gas pressure is admitted to the inside of the cylinder, the latter will expand according to known laws. The wire wrapping will also be expanded, increasing in length and decreasing in cross-section. These dimensional changes increase the resistance of the gage and cause a reduction in any current flowing through it. The records of this current change can be converted to the measured gas pressure by separate calibration.

The preceding methods have the disadvantage of requiring the modification of a gun barrel for each application. They further affect the normal bore processes by causing a small portion of the gases to enter and operate the pressure gage. It is possible to avoid these disadvantages by placing the gage directly on the gun barrel. Because of the large diameter involved, as well as the unsymmetrical shape of some barrels, it is not desirable to use a wrapped gage. For such work, a

small patch containing a length of wire laid in zigzag fashion is attached directly to the barrel. This patch is affixed with a cement and, after drying for a day, requires no other work to attach it. In corresponding fashion, the strain patch can be removed by pulling it off, leaving the barrel without any modification. In spite of the ease with which it can be removed, the patch adheres closely to the metal and records its strain accurately within its limits.

Although described here in connection with the measurement of bore pressure, the resistance patch can obviously be used to measure the deformation of gun parts in connection with any other study involving the acceleration or stress of a member.

11.4 VELOCITY

Velocity is an evanescent quality to measure. The moving body cannot be held in one place while the measurement is being made. This characteristic places a limit on the means which may be used to measure the velocity of a projectile. In other cases, the velocity of a body can be measured by recording the time it requires for the body to pass over a measured space of ground. Essentially the same thing is done in ballistic testing, but a long period of time cannot be used because the velocity will change in such a period, and the distance required to obtain an appreciable time interval rapidly becomes very large. For these reasons, other means were tried by early experimenters. Near the end of the eighteenth century, Benjamin Robins first fired cannon shot into a heavy pendulum in order to measure the velocity of the shot. From that time on, a pendulum used to measure velocity has been known as a *ballistic pendulum*.

The essence of this method is that a small mass moving with a high velocity is fired into a heavy body which is free to swing as a pendulum. As the projectile remains fast in the pendulum, the momentum of the combination after the im-

fact must be equal to that of the projectile before the impact. Further, the momentum imparted to the pendulum can be measured by measuring the height to which the pendulum swings. Hence

$$v = \left(1 + \frac{I}{Wd^2}\right) (2gh)^{\frac{1}{2}} \quad (\text{Eq. 33})$$

where v = projectile velocity (ft/sec),

I = moment of inertia of the pendulum about its point of suspension (lb-ft²),

W = weight of the bullet (lb),

d = distance from the suspension to the point of strike (ft),

g = gravity constant (ft/sec²),

h = height to which the point of strike rises (ft).

If the mass of the pendulum is concentrated in the lower part, this formula can be reduced to

$$v = \left(1 + \frac{m}{W}\right) (2gh)^{\frac{1}{2}} \quad (\text{Eq. 34})$$

where m is the weight of the pendulum in the same units as the weight of the bullet.

The best known of the early chronographs is that of Le Boulengé. This instrument operates from two electrical circuits through copper wire screens which are successively broken by the bullet. Each of these circuits contains a magnetic coil; the first supports a vertical rod, the other restrains a spring-driven knife. This instrument is shown in Figure 47. The breaking of the first screen releases the falling rod, which falls freely, and when the second circuit is broken, the knife marks that part of the rod which has fallen in front of it.

With increasing velocity this method becomes increasingly unsatisfactory. The use of bullets having long points renders it impossible to insure that the projectile will break the

screen rather than pass between the wires. Further, the small size of the projectile requires winding the screen with an exceedingly fine mesh.

The Boulengé instrument was based upon the decay of electrical fields in the electromagnets. Its underlying theory

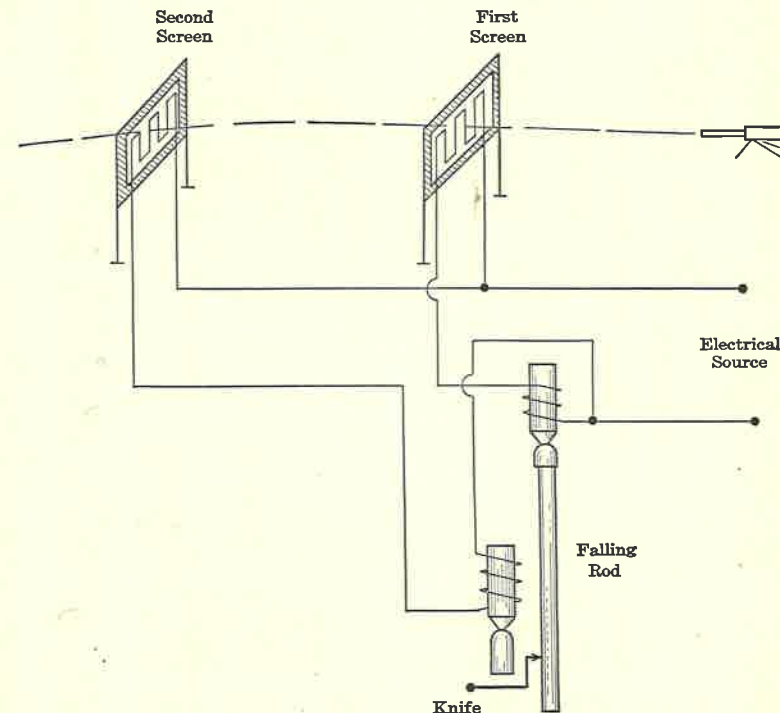

FIG. 47. Boulengé Chronograph.

assumes that these fields decay instantaneously. In practice, this is not so. Hence, the free-falling motion of the rods is modified and a source of error is introduced. The combination of mechanically moving parts with the electrical circuit also introduces uncertainties in the operation. Further, the increasing speed of modern projectiles shortens the interval between the two marks, with consequent decrease in the accuracy of reading.

In an effort to overcome these difficulties, the Aberdeen chronograph was developed. This instrument consists of a rotating drum, within the rim of which is placed a slip of paper. As the drum rotates at 1,800 rpm, the paper is held in place by centrifugal force. Two or more spark points project into the rim a short distance from the paper. These points are connected through suitable coils to screens through which the bullets are fired. These screens can be made of two layers of screening or metal foil, separated by an insulator. When the bullet passes through, the screens are momentarily shorted and the circuits are energized to produce a potential difference between the points and the metal rim of the chronograph. If two screens are used, two dots will appear on the paper, and the distance between them will be a direct measure of the time elapsed between their formation. As each of the circuits connected to a set of points is like the others, any electrical lag will be constant for every point, and may be neglected. As in the Boulengé chronograph, the work of the operator in reading the velocities is greatly facilitated by the use of special scales, calculated for the particular dimensions of the instrument.

It has already been shown how the wire screen of the Boulengé was superseded by other screens of a continuous nature in order to make a more reliable time indication. These screens, even though continuous, are damaged by the projectile (the Boulengé screen being destroyed entirely by each round) and eventually require replacement.

Besides the difficulties associated with proper screen functioning, all contact screens are unsatisfactory because they interfere with the flight of the projectile. The force required to penetrate or break the screen has its corresponding effect on the bullet. Its yaw may be changed; it receives a sudden retardation; portions of the screen may become attached to or trail with the bullet for some distance. To surmount these difficulties, improvements in screens have been developed.

These can be in the form of short coils through the center of which the bullet passes. If these coils contain an electric current, their field is changed by the passage of the projectile, and by means of suitable electrical circuits, this change may be made to discharge a spark. This effect can be amplified by magnetizing the projectile so that its magnetic field is added to the effect of the permeability of the metal, or use may be made of the electrostatic charge which the bullet always bears. The use of the latter is attended with difficulty, however, as the charge may be drawn off as the bullet passes through the first coil, or even as it passes through the air.

Photoelectric cells have recently been used to operate chronograph circuits. When placed at the bottom of a deep, thin trough, the cell is uniformly illuminated by light from the sky. Passage of the bullet close to the top of the trough changes the quantity of luminous flux falling on the tube and so initiates the signal through the chronograph circuit. These circuits must be carefully stabilized to avoid the occurrence of microphonics. Owing to the blast of the gun and the ballistic wave of the bullet, the photonic tube is subjected to shock and vibration. Should the elements within the tube alter their relative positions, false signals will confuse the record.

To eliminate all mechanical units from the chronograph, other electrical circuits can be used. If a condenser of known capacity is fully charged by a known voltage, the quantity of electricity stored in the circuit is known. The chronograph circuit can be so arranged that the passage of the bullet through the first screen starts the discharge of the condenser and passage through the second stops it. As the quantity of electricity discharged is an exponential function of time, the time itself may be determined from a measurement of the remaining charge. An elemental circuit of this type is shown in Figure 48.

Measurements of air resistance, or bullet retardation, necessary to exterior ballistic theory, are made by placing several coils in the path of the bullet and noting the various time intervals between the passage of the bullet through successive screens. For example, if the time of passage through

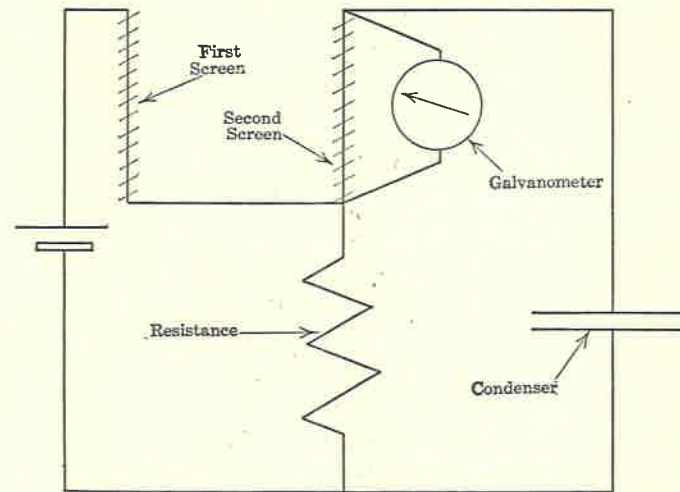

FIG. 48. Condenser Chronoscope.

four successive screens is $t_1, t_2, t_3,$ and $t_4,$ and the screens are located at distances $s_1, s_2, s_3,$ and s_4 (measured along the trajectory from any convenient point), then $v_{12} = \frac{t_2 - t_1}{s_2 - s_1}$

and $v_{34} = \frac{t_4 - t_3}{s_4 - s_3}$ are taken as the velocities at $\frac{s_1 + s_2}{2}$ and $\frac{s_3 + s_4}{2}$ respectively. The retardation between these points will be

$$a = \frac{v_{12} - v_{34}}{\frac{s_3 + s_4}{2} - \frac{s_2 + s_1}{2}} = 2 \left[\frac{\left(\frac{t_2 - t_1}{s_2 - s_1} \right) - \left(\frac{t_4 - t_3}{s_4 - s_3} \right)}{s_3 + s_4 - s_1 - s_2} \right] \quad (\text{Eq. 35})$$

11.5 ACCURACY

The term *accuracy* is used to designate what the statistician refers to as *precision*. Accuracy is a measure of the dispersion due to gun, mount, and ammunition and hence is a relative measurement, all other causes being assumed constant when one is being investigated.

Accuracy can be characterized by several measurements. When only a few shots are fired at a time, practically all the information available may be obtained by measuring the distance between outside shots of the group. Customarily three measurements are taken, the *extreme horizontal*, the *extreme vertical*, and the *extreme spread*. The last is the distance between the two shots most remote from each other. Another simple measure is the diameter of the smallest circle which will enclose the entire group. Again, this measure is best applicable to small groups or groups from weapons which do not fire automatically, as the latter tend to give targets which are very long in comparison to their width. As with all measurements which depend only on the extreme members for their values, there is always some speculation as to whether they may represent some sporadic or transient effect. In a modest effort to allow for this effect, instead of the circle which contains 100 per cent of the shots, one is sometimes used which contains only 80 per cent. This is known as an eighty per cent circle.

Targets are always measured in linear units. This necessitates that the range at which the target was placed be given before the significance of the measurement can be known. Of the shorter ranges used for this purpose, 1,000 in. (83 $\frac{1}{3}$ ft), 100 yards, 300 yards, and 600 yards are commonly used. The danger of using short ranges is not great when well-established bullets and barrels are used, but when new combinations are used, the longer ranges are desirable in order that the bullet may have time to settle down in its flight and in order that small effects may have time in which

to develop into measurable dispersions. The 1,000-in. range is used because of its relation to the angular unit the *mil*.¹ Actual measurements in inches may be recorded directly in either inches or mils without any conversion. The use of an angular measure of dispersion would have some advantages because the angular dispersion remains practically constant over moderate ranges.

More precise indexes of accuracy can be obtained by using all the shots on the target. This results in computation of

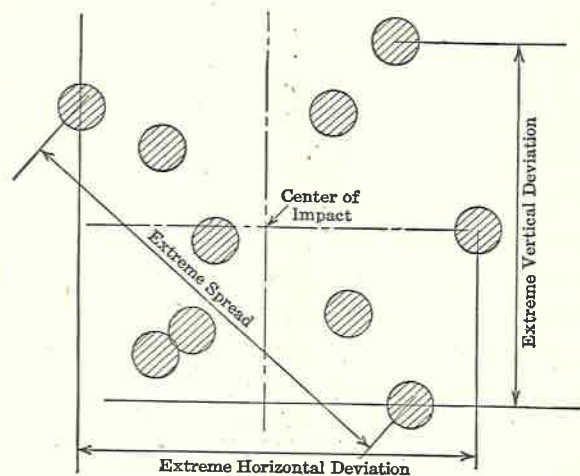

FIG. 49. Method of Measuring Targets.

the *center of impact*, the *mean horizontal deviation*, the *mean vertical deviation*, and the *mean radius*. The method of measurement is indicated in Figure 49. A base line is drawn through the shot hole on the extreme left of the target. The horizontal distance of each hole from this line is measured and the sum of these distances is divided by the number of shots. The resulting quotient is the horizontal coordinate of the center of impact, through which another vertical line is drawn. Next, the horizontal distances of the shots from a vertical line through the center of impact are measured. No

¹ A *mil* is an angle whose tangent is 1/1,000.

note is taken as to whether the shot is right or left of the center of impact. The average of these distances is the mean horizontal deviation. Similar work in the vertical direction locates the center of impact and provides the mean vertical deviation. With the center of impact located, the direct distance of each shot from it is measured, and these distances are averaged to produce the mean radius.

The foregoing may seem to be a large amount of work to apply just to the measurement of a target. However, in automatic fire, it is not unusual to find 100 per cent difference between targets fired under what seem to be identical conditions. Hence, if a correct analysis is to be made, it is necessary that a reliable and relatively stable statistic be determined from the target measurements. It is possible that application of the *standard deviation* rather than the mean deviation would produce more stable results and would result in obtaining the same amount of information with less firing. The standard deviation is computed in the same manner as described for the mean deviation except that the *squares* of the distances of each shot from the reference line would be added, divided by the number of shots, and the square root of the sum extracted.

11.6 FUNCTIONING

The proof of a pudding is in the eating, and likewise the proof of an automatic weapon is its ability to repeatedly perform its cycle. Hence, an endurance test of 5,000 to 10,000 rounds is of fundamental importance, and until recently, this was the only test ever made, all corrections being deduced from the sound of the weapon and the appearance of the parts after stopping owing to a malfunction or breakage. The endurance test is primarily a test of the strength, wearing ability, and general serviceability of all components of the gun. It should therefore be interrupted periodically to determine whether any change has taken place in these

components. If possible, any change in the performance of the gun should be correlated with this examination and the cause of such change detected. Of course, many such causes will have to be speculative until further firing and further investigation confirm or confute them. In this work, the parts should be mechanically gaged to check any wear of their surfaces; on those parts susceptible to heat, hardness measurements should be made to check drawing of the temper; springs should be weighed; and Magnaflux or similar tests should be taken to check for the formation of fatigue cracks. In making this overall check of the gun, there are a few measurements which can be readily taken to indicate whether the general functioning of the parts is in accordance with the predictions of the designer. The first of these is to measure the rate of fire. This can be done roughly by a stop watch, or more accurately by means of electrical instruments, of which there are many kinds. These record each cycle by marking each cycle upon a moving strip of paper. If the rate of this paper, say, 4 in./sec or 10 in./sec, is known, then the rate of fire can be easily computed from the formula

$$R = \frac{v(n-1)60}{s} \quad (\text{Eq. 36})$$

where R = rate of fire (rounds per min),
 v = velocity of the recording paper (in./sec),
 n = number of rounds recorded,
 s = distance spanned by the n shots (in.).

These recording instruments can be made to receive their signal in many ways. One way is to pick up the sound of the firing by a microphone. This requires careful volume control in order that only one characteristic sound per cycle shall operate the circuits. If there is some accessible part of the gun mechanism which oscillates, this can be made to operate an electrical contact on each shot, thus insuring that

all signals received are from the gun under test. All these instruments contain their own mechanism for producing the motion of the paper, and care must be taken to check this motion frequently by comparison with some known standard such as a tuning fork or a reliable source of alternating current.

It is also customary to check the motion of moving parts to insure that they complete their full cycle. This may be accomplished by painting with Prussian blue or a similar material and noting the area of contact. Where clearances may be in doubt, a piece of putty or modeling clay may be affixed to a surface and examined after the gun is fired.

In addition to the foregoing methods, modern instruments make possible recording of the most detailed motions of the component parts. Most useful of these is the high-speed motion picture camera. Operating with 8 mm or 16 mm film and exposing up to 8,000 frames a second, it detects vibrations and bounces whose existence could not have been otherwise observed.

In order to check the velocities and accelerations of the moving parts, a camera has been designed which directly plots the motion of selected parts against a time base. A sketch of such a camera is shown in Figure 50. To use this method it is necessary that the part being investigated move in a straight line (or that the measurement be limited to the straight-line component of the part) and that it be provided with a single point which will reflect light into the camera. The camera in turn is provided with a focal plane slit or cylindrical lens which illuminates only a very narrow strip of the record. The recording is made directly upon light-sensitive paper. As the drum upon which the paper is mounted rotates at a uniform speed, and as the slit exposes only an extremely small portion at each instant, the image of the moving object will be transformed into an inclined line. From the slope of this line the velocity of the moving part

can be readily determined. Also, variations from a straight line will show the presence of accelerations or impacts, and the measured velocities can be used to check the engineering calculations of energy and momentum contents. The time-space graph of Figure 26 was produced by this method.

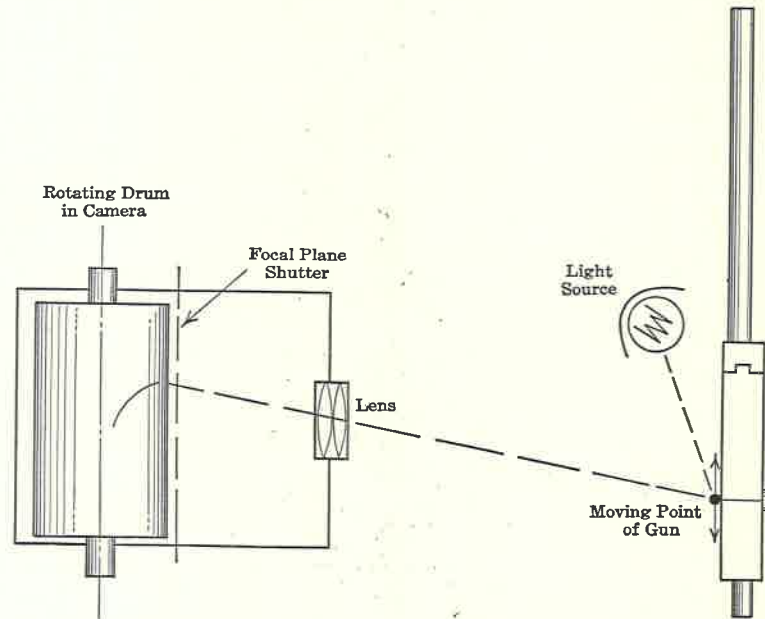

FIG. 50. Time-Displacement Camera.

While this type of camera is at present limited to recording straight-line motion, it is of much assistance as it saves the enormous amount of tiring and difficult labor which was formerly necessary to reduce to plots the motions of moving parts as recorded on individual frames of high-speed motion picture film.

When a gun is to be attached to any other structure, such as the wing of an airplane, it is essential to know the forces which the gun will transmit to the mount. As these forces are dependent upon the deflection of the mount, it is obvious that the gun and the mount must be analyzed together.

Where, however, it is not possible to do this, the reactions of the gun against a rigid mount can be taken. The word *rigid* must be used in a relative sense, as no structure can be truly rigid. In this case, a mount having great mass and a high modulus is required. Such an installation will develop the maximum forces of which the gun is capable, whereas an elastic mount will lower the forces and increase their times of application.

Such measurements are known as *trunnion reactions* or *force intervals*. In contrast to the long, smooth push of a recoiling cannon, an automatic weapon produces an irregular series of impact blows. These impacts are caused when the elements of the mechanism react against the receiver of the gun. It is one of the goals of the gun designer to extend these force periods so as to secure low mounting loads and to reduce the peak impact forces to which the parts might be subject.

The study of these force interval records in conjunction with the time-displacement records previously described can furnish valuable information as to the momentum and energy exchanges during the operation of the gun cycle and can indicate where the mechanism is liable to improvement.

Dependent upon the space available, any of the electrical methods mentioned in connection with the measurement of pressure may be used to obtain this information. The strain patch may be used in almost all locations to give a measurement of surface stresses. It is particularly adapted to the measurement of stresses at almost inaccessible points. When mounting reactions are to be measured, a choice of methods is available, both the piezoelectric method and strain gages having been successfully applied.

11.7 PENDULUM MEASUREMENTS

In Section 11.4 the method of measuring velocity by receiving the projectile in a freely swinging pendulum was

described. Gun recoil and powder gas velocity are measured by using the gun itself as the bob of such a pendulum. This arrangement is shown in Figure 51. The weapon is suspended by at least five wires in order to insure a recoil that will not result in rotation of the gun about a vertical axis. Such rotation would vitiate the accuracy of the work, as only the translatory motion of the gun can be measured by

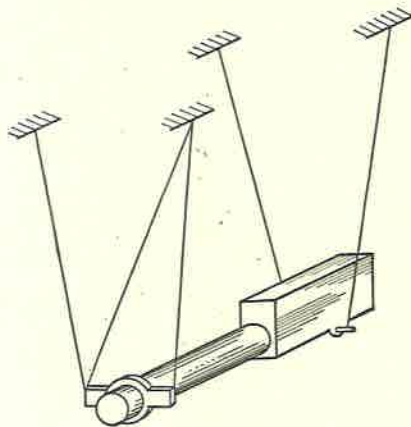

FIG. 51. Ballistic Pendulum.

the pendulum. From the momentum equation it is known that the total momentum of the recoiling gun, the projectile, and the powder charge must equal zero. Of these items, all the masses (or weights) are known, the velocity of the projectile can be measured by chronograph, and the velocity of the gun can be measured from the recoil of the pendulum. There remains unknown only one factor, the average velocity of the gases. This can be calculated from

$$v_c = \frac{Gv_G - Wv_W}{c} \quad (\text{Eq. 37})$$

where v_c = velocity of the gases (ft/sec),
 G = weight of the gun (lb),
 v_G = velocity of the gun (ft/sec),

W = weight of the projectile (lb),
 v_W = velocity of the projectile (ft/sec),
 c = weight of the powder charge (lb).

BIBLIOGRAPHY

- CRANZ, C., *Lehrbuch der Ballistik*, Band III (Experimentelle Ballistik), Leipzig, Springer, 1927.
- DOANE, F. B., *Principles of Magnaflux Inspection*, Chicago, Photopress, Inc., 1942.
- EDGERTON, H. E., GERMESHAUSEN, J. K., and GRIER, H. E., "High Speed Photographic Methods of Measurement," *J. Applied Physics*, Vol. 8, p. 2, 1937.
- FORD, A. W., "Instruments for Making Ballistic Determinations," *Army Ordnance*, Vol. VII, p. 113, 1926.
- JERVEY, F. J., "A Standard Method for Measuring Small Arms Targets," *Army Ordnance*, Vol. VIII, p. 10, 1927.
- KENT, R. H., and HODGE, A. H., "The Use of the Piezoelectric Gage in the Measurement of Powder Pressures," *Trans. Am. Soc. Mech. Engrs.*, Vol. 61, p. 197, 1939.

APPENDIX A

EXTERIOR BALLISTICS

A·1 INTRODUCTION

Exterior ballistics is the study of the motion of a projectile in a resisting medium. The flight of a body is governed by its initial velocity, the nature of the medium through which it travels, its own form and mass, and gravity. The path over which it travels is called a *trajectory*. The gun is located at the *origin* of the trajectory and the target or other stopping point at its *end*. The force exerted by the air in resisting the motion is referred to as the *air resistance*.

A·2 AIR RESISTANCE

Air resistance is a function of the shape of the projectile and the area which it presents to the air; as projectiles are customarily round in section, this area is equal to $\pi d^2/4$, where d is the caliber. The air resistance is also a function of the velocity with which the projectile is moving. This is a complex function which, in its entirety, cannot be represented by a simple algebraic relation. For the present this force will be designated simply as $f(v)$.

From Newton's laws it is known that the deceleration of a body will be equal to the force acting on the body divided by its mass. If the weight of the projectile is W , then the deceleration

$$a = \frac{\pi d^2 g f(v)}{4W} \quad (\text{Eq. 38})$$

If the constants $\pi g/4$ are represented by c , then

$$a = \frac{cf(v)}{W/d^2} \quad (\text{Eq. 39})$$

Now, W/d^2 is a function of the projectile only. As the value of this group determines the ability of the bullet to withstand the effects of air resistance, it is called the *ballistic coefficient*. As all projectiles are not of the same shape, $f(v)$ will be different for each type. For short ranges, it may be assumed that the resistances of two different projectiles have a constant ratio. Then, knowing $f(v)$ for one projectile, the resistance of another may be obtained by using a factor i . This is the *form factor*, which is used to determine the resistance of one bullet from that of another whose resistance function is already known. It is usually determined by comparative firings, although approximate mathematical methods also exist. When modified to include this element, the ballistic coefficient becomes W/id^2 .

In attempts to make mathematical computation of trajectories easier, many formulas have been developed to represent the air resistance function of common projectile forms. Mayevski arbitrarily defined several velocity zones and established an exponential relation for the air resistance in each zone. These formulas are ¹

VELOCITY ZONE (ft/sec)	AIR RESISTANCE
0 to 790	$4.676 \times 10^{-5}v^2$
790 to 970	$5.935 \times 10^{-3}v^3$
970 to 1,230	$6.337 \times 10^{-14}v^5$
1,230 to 1,370	$9.570 \times 10^{-3}v^3$
1,370 to 1,800	$1.316 \times 10^{-4}v^2$
1,800 to 2,600	$1.248 \times 10^{-3}v^{1.7}$
2,600 to 3,600	$4.065 \times 10^{-3}v^{1.55}$

It is seen that the resistance $cf(v)$ is of the form kv^n for each zone.

This form of equation was chosen because its use rendered possible the solution of certain exterior ballistic problems.

¹ These values have appeared in several publications, although the logarithm of the coefficient and not its natural value is given. The particular reference used in this case was *Artillery Circular M*.

The use of other mathematical forms produced equations which could not be solved.

A.3 APPROXIMATE COMPUTATION OF A TRAJECTORY

The exact computation of a trajectory requires an extensive mathematical analysis, and the student should consult the references for more detailed instructions. For *short ranges only* a considerably simplified procedure may be employed.

Figure 52 shows that the projectile is affected by two forces, air resistance and gravity. For high velocities and

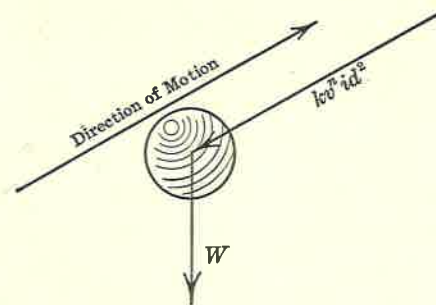

FIG. 52. Forces on Projectile.

short ranges, the effect of the air resistance will be much greater than that of gravity. In such case, the projectile will not depart greatly from its original direction, and the effects of these two forces may be taken separately. Owing to the nature of the formula selected for the air resistance function, it is easier to compute the distance required to reach a given velocity than to compute the remaining velocity after a given range. Where the values are tabulated (as in the references listed), this is of little moment.

The distance covered is expressed by

$$X = \frac{C}{k(2-n)} \left[\frac{1}{v_x^{n-2}} - \frac{1}{v_0^{n-2}} \right] \quad (\text{Eq. 40})$$

and the time of flight over that distance by

$$T = \frac{C}{k(1-n)} \left[\frac{1}{v_x^{n-1}} - \frac{1}{v_0^{n-1}} \right] \quad (\text{Eq. 41})$$

where X = range in question (ft),

T = time of flight (sec),

C = ballistic coefficient W/ia^2 (lb/in.²),

k = appropriate coefficient from Section A.2,

n = appropriate exponent from Section A.2,

v_x = velocity of the end of range X (ft/sec),

v_0 = velocity at beginning of range X (ft/sec).

The vertical drop of the projectile due to gravity will be very nearly

$$y = \frac{gT^2}{2} \quad (\text{Eq. 42})$$

It must be remembered that this method is approximate and does not give reliable results after the trajectory begins to curve appreciably.

A.4 MOTION OF THE PROJECTILE ABOUT THE TRAJECTORY

The previous discussions have neglected the *aspect* of the bullet. That is, no mention was made as to whether or not its long axis coincided with the trajectory. If it does not, the area presented to the air will be increased and the ballistic coefficient decreased.

In actual flight, the projectile does not remain head-on along the trajectory. Owing to disturbances incurred during acceleration and launching, the bullet is wobbling transversely when it leaves the gun. Owing to the spin imparted by the rifling, this wobble is damped out in a short time so that at greater ranges the bullet will be more nearly head-on than when near the muzzle. The variation of the bullet from the head-on position is known as *yaw*.

Some bullets, improperly designed, do not decrease their yaw; these are said to be *unstable*. Conversely, a *stable* bullet is one for which the yaw will decrease until the bullet attains a smooth motion along its trajectory. Stability is largely a matter of spin, it being possible to stabilize any bullet if the twist of rifling is made sufficiently steep. If the motion of a stable projectile is examined by placing a number of sheets of cardboard in its path, it will be found that the yaw does not diminish smoothly, but rather by a sort of looping motion. Further, the direction in which the bullet points will rotate about the trajectory. These phenomena are known as nutation and precession and are similar in nature to astronomical phenomena bearing the same names.

BIBLIOGRAPHY

- BLISS, G. A., *Mathematics for Exterior Ballistics*, New York, John Wiley & Sons, Inc., 1944.
- CRANZ, C., *Handbook of Ballistics*, Vol. I, Translation by the British War Office, London, H. M. Stationery Office, 1927.
- HERRMANN, E. E., *Exterior Ballistics*, U. S. Naval Institute, Annapolis, Md., 1935.
- Ingalls' Ballistic Tables* (Artillery Circ. M), Washington, D. C., U. S. Government Printing Office, 1918.
- JOHNSON, M. M., JR., and HAVEN, C. T., *Ammunition*, New York, William Morrow & Co., 1943.
- JONES, F. W., *The Hodsock Ballistic Tables for Rifles*, London, E. Arnold, 1925.
- KENT, R. H., "The Flight of the Projectile," *J. Franklin Inst.*, Philadelphia, Vol. 225, p. 19, 1938.
- MANN, F. W., *The Bullet's Flight from Powder to Target*, Huntington, W. Va., Standard Printing & Publishing Co., 1942.
- MOULTON, F. R., *New Methods in Exterior Ballistics*, Chicago, University of Chicago Press, 1926.

APPENDIX B

GUN MOUNTS

B-1 INTRODUCTION

When an automatic gun is used to fire during a long period of time without being moved, it is required that a *mount* be provided for it. The mount is also used to absorb the recoil or kick of the gun in order that more accurate firing may be obtained. A further advantage is that the gun may readily be brought to bear upon its targets because the firer is not required to support its weight.

The development of mounts for antiaircraft purposes has opened new fields of design. This usage has required the development of light, portable mounts of great stability. The ability to move the gun quickly in all directions is paramount. With such freedom of motion, however, it is essential that the gun be under control at all times.

B-2 STABILITY

It is necessary that a gun mount remain fixed in its position during firing. One that does so is termed a *stable* mount, while one that rises or overturns is said to be *unstable*.

The static diagram of forces acting on a gun mount is easily drawn. It can be seen that the couple of the force F (the recoil force) about the rear support O must not exceed that formed by the weight of the mount W . If the force couple is greater, then the mount will tip over backward, to the discomfiture of the firer. For any given gun, the factors affecting the stability of the mount are its weight, the height of the gun (command), and the rearward projection of the

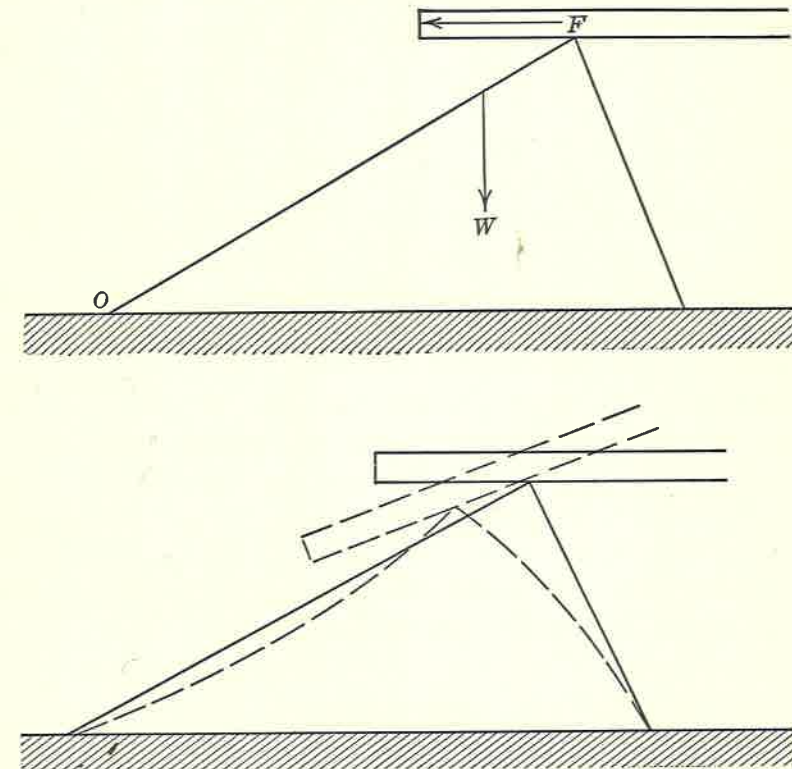

FIG. 53. Force System on Mount.

leg in a preferred direction, but care is taken to secure as large a leg circle as possible. These legs must lie close to the ground in order that the gunner will not trip over them. They are limited in length by transportation requirements.

Delving more deeply into the action of the mount during firing, it is seen that even though the couple applied is not sufficient to overturn the mount, the elastic nature of the mount causes it to deflect during the firing and point the gun

in a direction other than that in which it was aimed. This is shown by the lower view in Figure 53. It has been noted in Chapter 3 that the firing forces act only for a very brief period of time, and hence would effect an impact blow upon the mount. Should this be repeated many times in rapid succession, as when firing an automatic weapon, the mount would vibrate violently, and hitting the target would become impossible.

In artillery, where only single shots are fired, it has been the practice since about 1897 to attach the gun to the mount by a sliding, elastic connection. This unit is called a *firing brake*, or *recoil mechanism*. Its function is to reduce the brief, intense firing force to a longer, weaker one, extending the firing cycle over several seconds for a single shot instead of a few hundredths of a second. With the development of small-caliber machine guns, no effort was made to use such devices on mounts, with the result that machine gun accuracy was poor. This deficiency has been noted, and practically all mounts now being designed include an elastic device to smooth out the firing forces. As many of them are afterthoughts, and were added to the mount after the time of its original design, they are generally referred to as *recoil adapters*, although where built integrally into the structure, they may be called *recoil mechanisms*.

The primary purpose of a recoil adapter is to smooth the firing forces and to exert on the mount a smooth, continuous force, rather than a series of impulses. Figure 54 shows in general the nature of this change. The result, of course, is to impose an initial deflection on the mount at the first shot, and to maintain this deflection nearly constant during the burst of fire.

It must not be forgotten that, while one end of the adapter is attached to the mount, the other end is fastened to the gun. Further, it derives its action from the fact that it permits the gun to move much more flexibly than if the adapter were not

present. Automatic weapons operate by inertia and spring forces after the initial firing shock. Hence, motion of the gun frame will affect the free motions of the contained parts. In some mounts, the motion is such that the receiver can

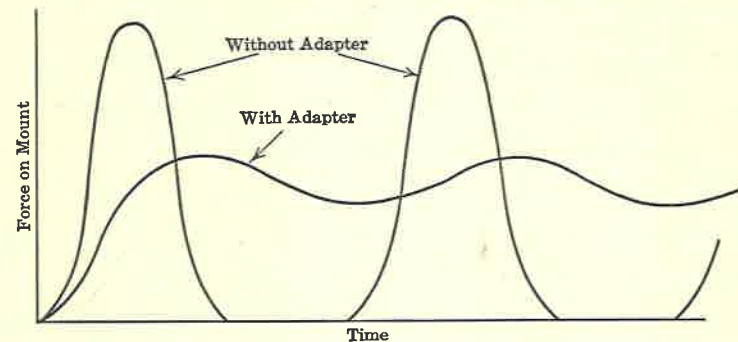

FIG. 54. Effect of Recoil Adapter.

move in the same direction as the bolt, and if the latter does not possess enough energy to fully compress the firing spring, malfunctions will occur frequently.

B-3 FIELD OF FIRE

The tactical employment of a gun should not be limited by its mount. Formerly, a mount was merely a tripod footing for the gun, and changes in gun pointing had to be made by moving the mount. Later, screw-actuated elevating and traversing mechanisms were included in order that the fire might be slowly and accurately adjusted to various targets. Provisions were made for rapid changing of direction over large angles.

With the increased use of the machine gun for anti-aircraft fire, new types of mounts have been developed. In general, these mount the gun high above the ground, and provide only for rapid, free motion to allow the gunner to track low-flying airplanes. Emphasis has been placed upon rapidity and ease of gun control to the detriment of stability

and accuracy. As a general rule, the mount for a light gun need provide only a limited field of fire but must be capable of continued and accurate fire in that direction. When anti-aircraft fire is to be delivered, that mount must be able to cover the entire upper hemisphere readily.

B-4 STRUCTURE

The elements described in the preceding paragraphs can be combined in many ways. Figure 55 shows the elements of

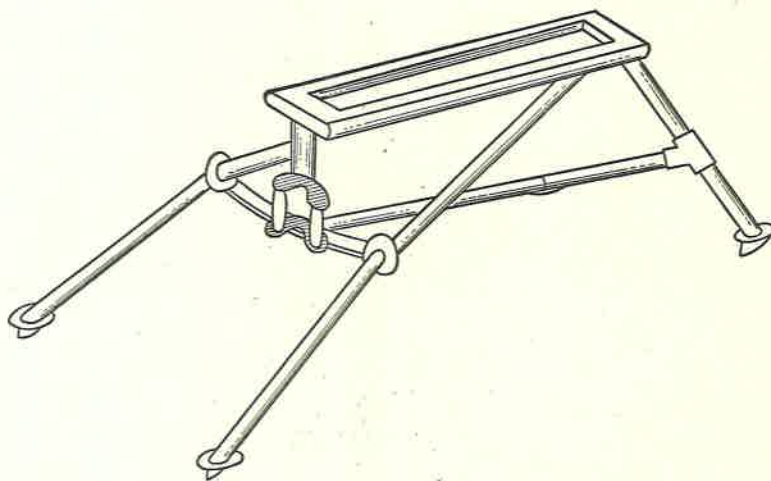

FIG. 55. German Type Tripod.

the German tripod for the MG34. This consists basically of a triangular frame, which is supported on three adjustable legs. Upon this structure is raised the gun support, which can be moved horizontally about its front end as a pivot. This support in turn carries a recoiling cradle which modifies the recoil of the gun. Elevation changes are secured by varying the length of the vertical member at the rear end of the gun support.

INDEX

A

Abbreviations, 4
 Acceleration, bolt, 64
 Accuracy, measurement of, 121
 Action, inertia, 40, 52
 Air resistance, 131, 132
 effect of, on trajectory, 133
 measurement of, 120
 Ammunition, definition of, 2
 Artillery, definition of, 1
 Automatic action, definition of, 2
 types of, 39
 Automatic cannon, definition of, 2
 Hispano-Suiza, 51, 67
 Automatic pistols, 2

B

Ballistic coefficient, 132
 Ballistic pendulum, 115, 128
 Ballistics, exterior, 131
 interior, 7
 LeDuc's method, 8
 Barrel, cooling, 17
 by radiation, 19, 100
 by water, 19
 design, 8
 erosion, 97
 expansion due to heating, 18
 heat flow through, 18, 19
 heating, 17
 material, 100
 strength, 11, 13
 stresses in, 11
 tapered bore, 20
 efficiency, 21
 Gerlich, 20

Barrel, temperature, 100
 vibrations, 13
 Belt, cartridge feed, 60, 80
 disadvantages, 82
 fabric, 80
 metal link, 80, 81
 Blowback action, 40
 calculation of, 41
 delayed, 42
 Blueing, 101
 Booster, muzzle, 49
 use of, 55
 BORCHARDT, H., pistol, 43
 Brake, firing, 138
 hydraulic, 27
 muzzle, 26
 recoil, 25
 Breakages, prevention of, 108
 Breech closures, 31
 Browning, 101
 BROWNING, J. M., 3
 trigger mechanism, 75
 Browning machine gun, .30 air-
 craft, 54
 Bullet, definition of, 3

C

Caliber, definition of, 1
 Camera, high-speed, 125
 time-displacement, 125
 Cartridge, definition of, 2
 Cartridge case, 2, 3
 Center of impact, determination of,
 122
 Chamber, floating, 50
 Change lever trigger mechanism,
 76

Charge energy, division of, 17
 Charger, cartridge, definition of, 84
 Chronographs, 116
 Aberdeen, 118
 condenser, 119
 electrostatic, 119
 Le Boulengé, 116
 solenoid, 119
 Clip, cartridge, definition of, 83
 Cocking, 38
 Browning machine gun, 59
 Compensator, 27
 Complete round of ammunition, 2
 Composite systems, Hispano-Suiza, 67
 Cooling, barrel, 100
 Copper crusher gage, 111
 Copper cylinders, 112
 Copper spheres, 112
 Coppering, 97
 Corrosion, 101
 protection against, 101
 by dehydration, 102
 Cosmolene, 102

D

Definitions, 1
 Delayed inertia action, 40
 Hispano-Suiza, 67
 Drift of projectile, 87
 correction for, 88
 Drop of projectile, 134

E

Ejection, 36
 Erosion, 97, 99
 chemical, 99
 gas port, 101
 mechanical, 99
 theories of, 99
 thermal, 99
 Expansion, 104

Exterior ballistics, 131
 Extraction, 34

F

Feed, cartridge, 29, 78
 Feed belt, 58, 61
 Firearms, first used, 3
 Firing, premature, prevention of, 67
 Firing means, 31
 Firing pin, fixed, 62
 types of actuation, 72
 Flintlock, 3
 Flip, 13
 Force interval, 127
 Form factor, 132
 Fouling, metal, 97, 98, 103
 powder, 103
 primer, 103
 FOWLER, E., firing mechanism, 74
 FULLER, C. E., 11
 Functioning, 29, 123

G

Gage, pressure, 111, 113
 resistance, 114
 Garand rifle clip, 84
 Gas booster, 49
 Gas cylinder, 47
 Gas expansion action, White, 48
 Gas-operated action, 46
 Gas-operated weapon, Japanese
 Model 99, 65
 Gas port, design of, 101
 erosion of, 101
 Gas tappet action, 49
 Gatling gun, 3
 GERLICH, H., tapered bore, 20
 Gravity, effect on trajectory, 133
 GRAY, J. C., 99
 GREENER, W. W., 3
 Gun, mechanical, 3
 Gunpowder, 103

H

Hammer, 34
 Hand arms, definition of, 1
 HAWKINS, G. A., 19
 High velocity, in tapered-bore barrels, 20
 Hispano-Suiza automatic cannon, 51, 67
 History of firearms, 3
 Hopper, cartridge feed, 85
 Hotchkiss machine gun, feed strip, 83

I

Impact, center of, 122
 Inertia action, 40, 52, 67
 Interior ballistics, LeDuc's method, 8
 Interval, force, 127

J

Jacket, water, 100
 JAKOB, M., 19
 Japanese Model 99 light machine gun, 65
 Japanese Nambu light machine gun, hopper feed, 85
 Johnson light machine gun, magazine, 80
 JOHNSTON, W. A., 11
 Jump, 25, 87

L

Lead, 89
 Leaf, sight, 92
 LE BOULENGÉ, P., 116
 LeDuc's method, 8
 Link belt, 80
 Link chutes, 82
 Locking, 31
 Long recoil action, 45

Lubricant, effects of excess, 104
 Lubrication, 104
 Luger pistol, 44

M

Machine gun, Browning Cal. .30, 54
 definition of, 2
 gas-operated, invention of, 3
 heavy, 3
 Japanese Model 99, 65
 Japanese Nambu, hopper feed, 85
 Johnson, magazine, 80
 Madsen, magazine, 80
 Mauser, 61
 recoil-operated, invention of, 3
 used as artillery, 3
 Magazine, cartridge, 79
 drum, 80
 Magazine weapons, classification of, 2
 Malfunctions, 106
 analysis, 107
 causes, 106
 correction, 107
 investigation, 106
 Mannlicher rifle clip, 84
 Matchlock, 3
 Mauser cartridge charger, 84
 Mauser machine gun MG151, 61
 MAXIM, H., 3
 McADAMS, W. H., 20
 Measurement by pendulum, 127
 Mechanism, analysis of, 127
 gas-operated, 46, 65
 MENDOZA, R., trigger mechanism, 76
 Metal, barrel, effect of heat on, 8
 Metal fouling, 97, 98, 103
 Mil, definition of, 122
 Mount, 136
 deflection of, 137

- Mount, in relation to field of fire,
139
forces on, 136
stability of, 136
structure of, 140
Muzzle enlargement, 97
- N**
- Nambu light machine gun, hopper
feed of, 85
- O**
- Obturing, 31
- P**
- Parkerizing, 101
Pendulum, ballistic, 115, 128
measurement by, 127
Percussion gun, 3
Photoelectric cell, uses for, 119
Piezoelectric pressure gage, 114
Pin, firing, 33
Plating of barrel, chromium, 100
Powder, residues of, 102
Powder fouling, 103
Precession, projectile, 135
Premature firing, device to prevent,
67
Pressure, barrel, 7
electrical measurement of, 113
errors in measurement of, 113
in bore, calculation of, 9
maximum, calculation of, 9
measurement, by coppers, 111
by piezoelectric crystals, 113
muzzle, 49
Pressure-travel relation, 9
Primer, composition of, 103
internal, 3
Primer fouling, 103
- Projectile, deceleration of, 131
drift of, 87
drop of, 134
motion of, about trajectory,
134
Propellant, nitrocellulose, 103
products of combustion of, 103
Propellant gases, velocity of, 26
Propellant residues, 103
Puff, C., tapered bore, 20
- R**
- Radius, sight, 93
Rate of fire, measurement of, 124
Reaction, gun, measurement of,
126
trunnion, 127
Recoil, causes of, 22
free, 22
maximum velocity of, 24
measurement of, 128
momentum of, 128
retarded, 25
Recoil action, long, 45
short, 43
Recoil adapter, 138
Recoil brake, 25
Recoil mechanism, 138
Recoil-operated weapon, 54, 61
Resistance, air, 131, 132
effect of, on trajectory, 133
measurement of, 120
Resistance gage, 114
Rifling, 14
force due to, 15
proportions of, 16
shape of, 15
twist of, 14
ROBINS, B., 115
RODMAN, T. J., 111
Round of ammunition, elements of,
2
Rust preventive, 102

- S**
- Schwarzlose machine gun, action of,
42
Sear, 38
force to operate, 71
Sear mechanisms, 70, 74
Semiautomatic, definition of, 2
Separate loading, 3
Short recoil action, 43
Shoulder arms, definition of, 1
Sight, 86
aperture, 88, 92
battle, 91
blade, 88
computing, 89, 94
correction for jump, 87
dial, 96
front, 86, 88
machine gun, 96
glass, 86
graduations on, 87
iron, 86
optical, 86, 95
peep, 91
post, 88
purpose of, 86
ramp, 93
rear, 86
apertures in, 91
fixed, 92
folding leaf, 92
ramp, 92
ring, 88, 89, 94
tangent, 93
Sight radius, 93
Slide, sight leaf, 92
Small arms, definition of, 1
Spin, bullet, 135
Springs, 27, 108
life of, 109
surge of, 109
Stability, of bullet, 135
of mounts, 136
- Stabilizer, 27
Stoppages, 105
causes, 105
prevention, 105
Stresses, barrel, 8
surface, measurement of, 127
Strip, feed, 82
Submachine gun, 52
U. S. Cal. .45, M3, 52
Symbols, 4
- T**
- Tarage table, 112
Target measurement, 121
Telescopic sight, 95
Temperature, effects of, 104
barrel, 7
Testing of weapons, 111
Time-displacement record, 55
Tracer bullets, use of, in sighting, 90
Tracer control, 90
Trajectory, computation of, 133
curved by drift, 87
curved by wind, 87
definition of, 131
effect of air resistance on, 133
Trigger, force required to operate,
71
location of, 71
requirements of, 71
types of, 70
Trigger mechanism, 70
convertible, 76
full automatic, 72
semiautomatic, 75
Trunnion reactions, 127
- U**
- Units, 4
U. S. Rifle, Cal. .30, M1903, 73
U. S. Submachine Gun, Cal. .45,
M3, 52

V

Velocity, measurement of, 115
Velocity-travel relations, 9

W

Water jacket, 100
Weapons, multiple barrel, 3

Wheel lock, 3
WHITE, J. C., gas expansion system, 48
WILLIAMS, D. M., floating chamber system, 50

Y

Yaw, 134