

Service Manual: SYSTEM WIRING DIAGRAMS

## **ACTIVE BODYWORKS**

Fig 1: Active Bodyworks Circuit

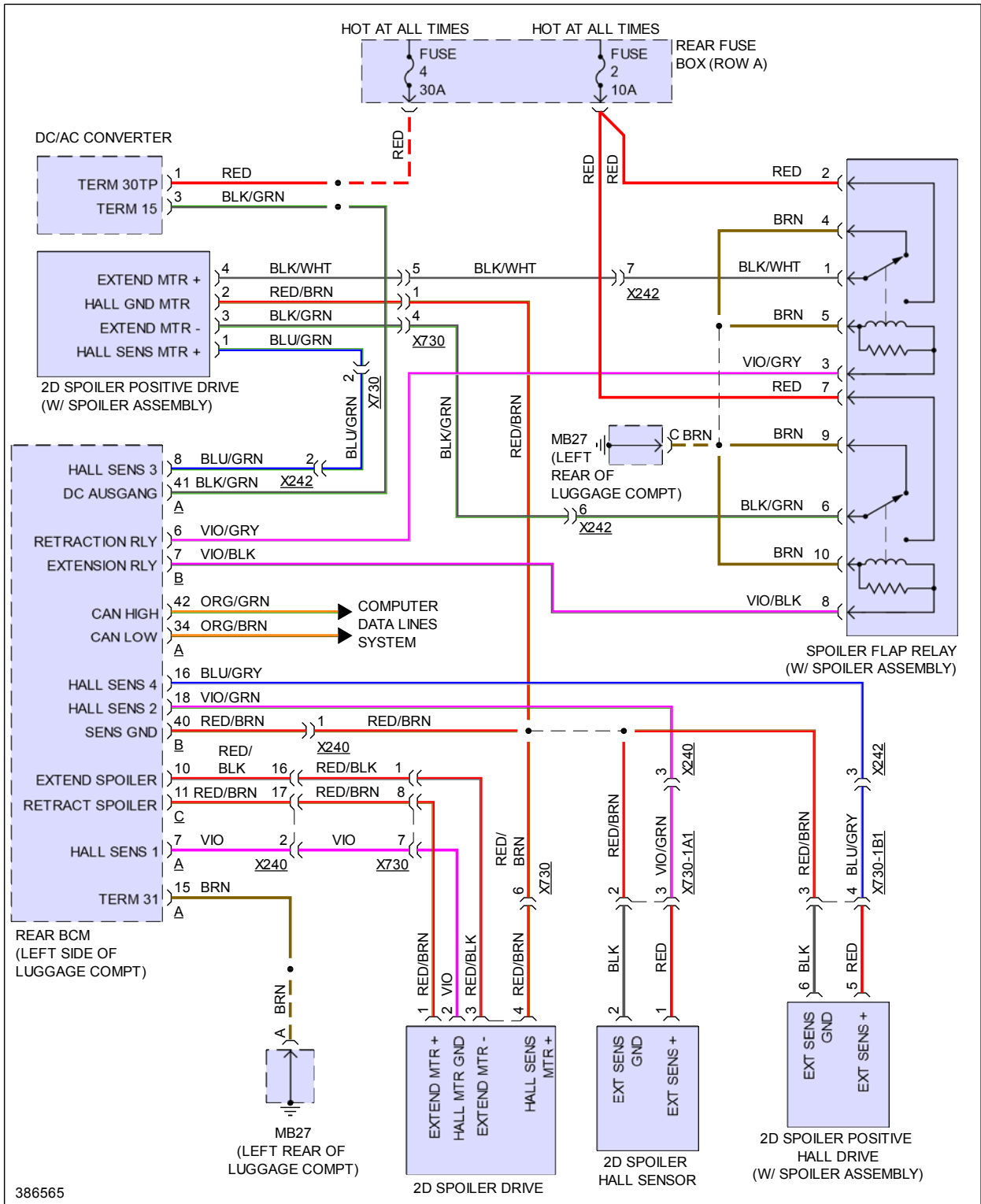

386565

# AIR CONDITIONING

Fig 1: Automatic A/C Circuit, Except Hybrid (1 of 4)

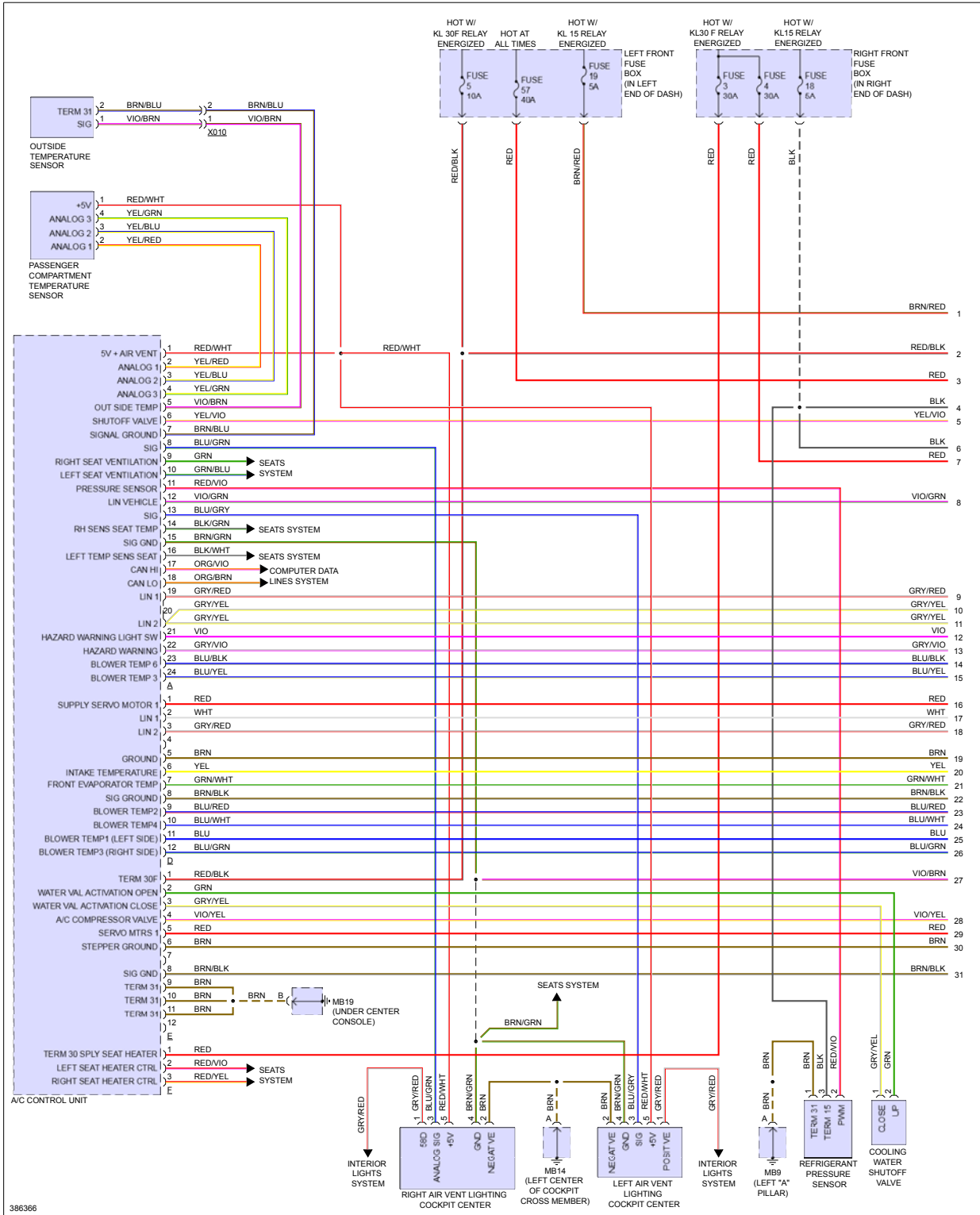

Fig 2: Automatic A/C Circuit, Except Hybrid (2 of 4)

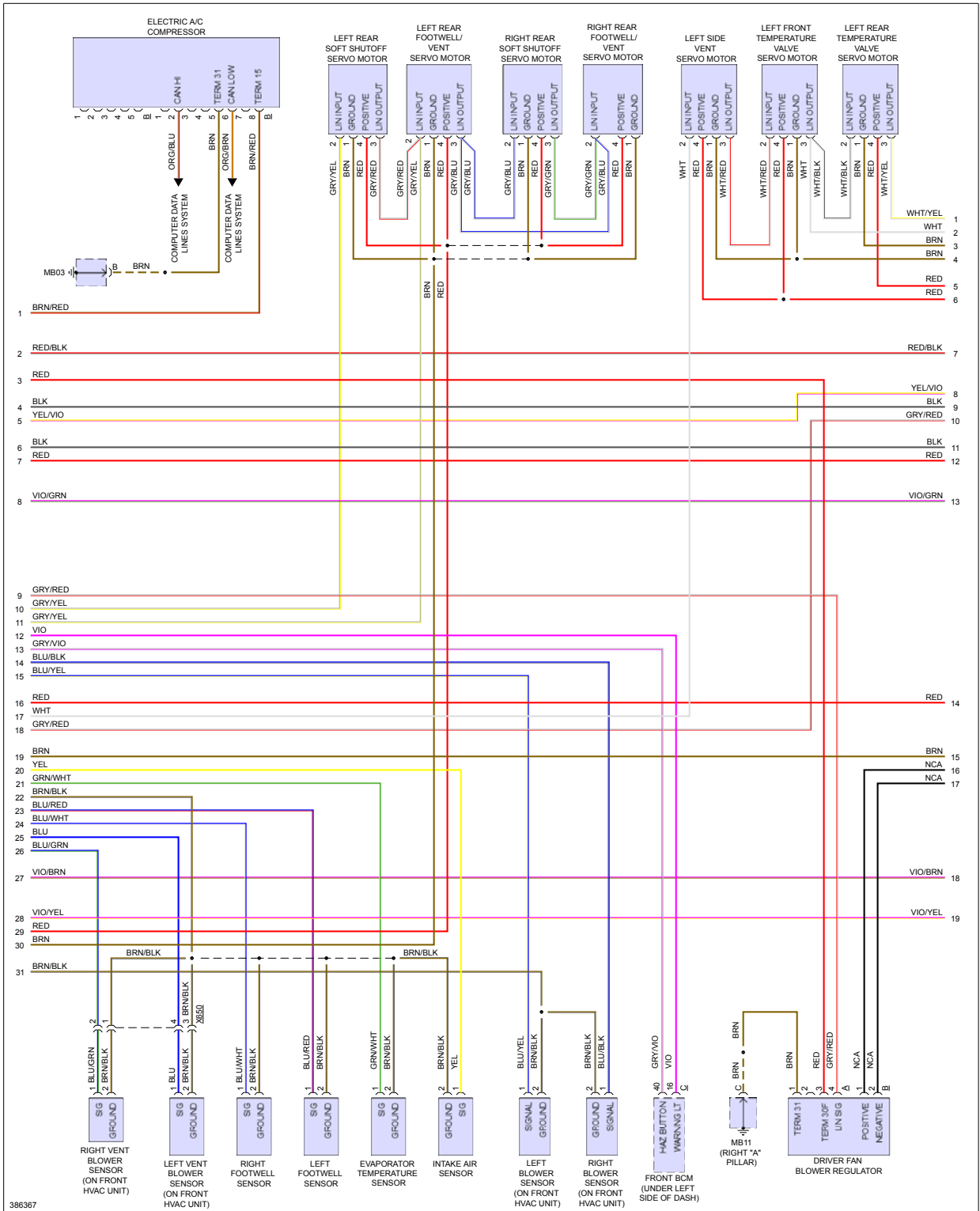
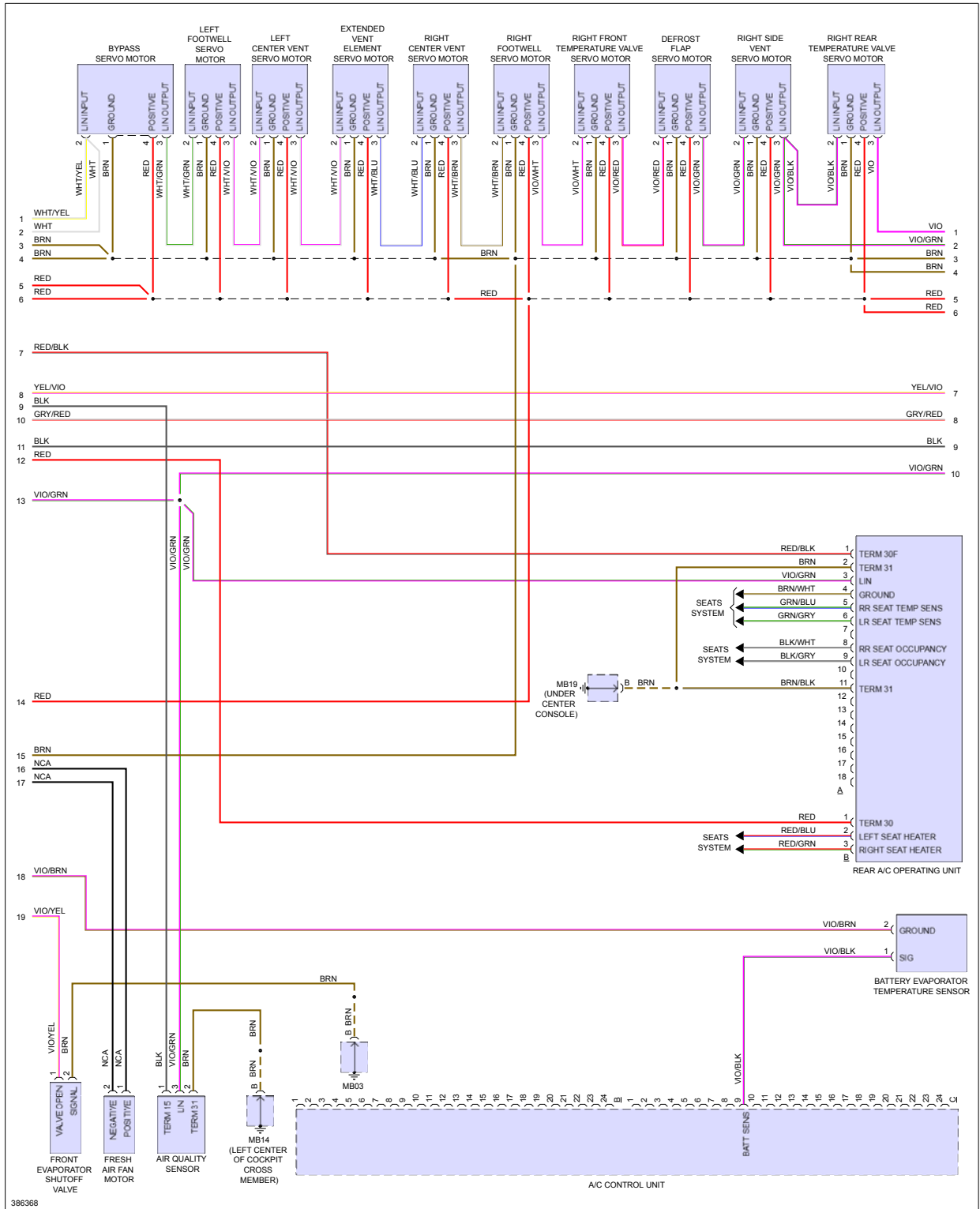

Fig 3: Automatic A/C Circuit, Except Hybrid (3 of 4)



386368

Fig 4: Automatic A/C Circuit, Except Hybrid (4 of 4)

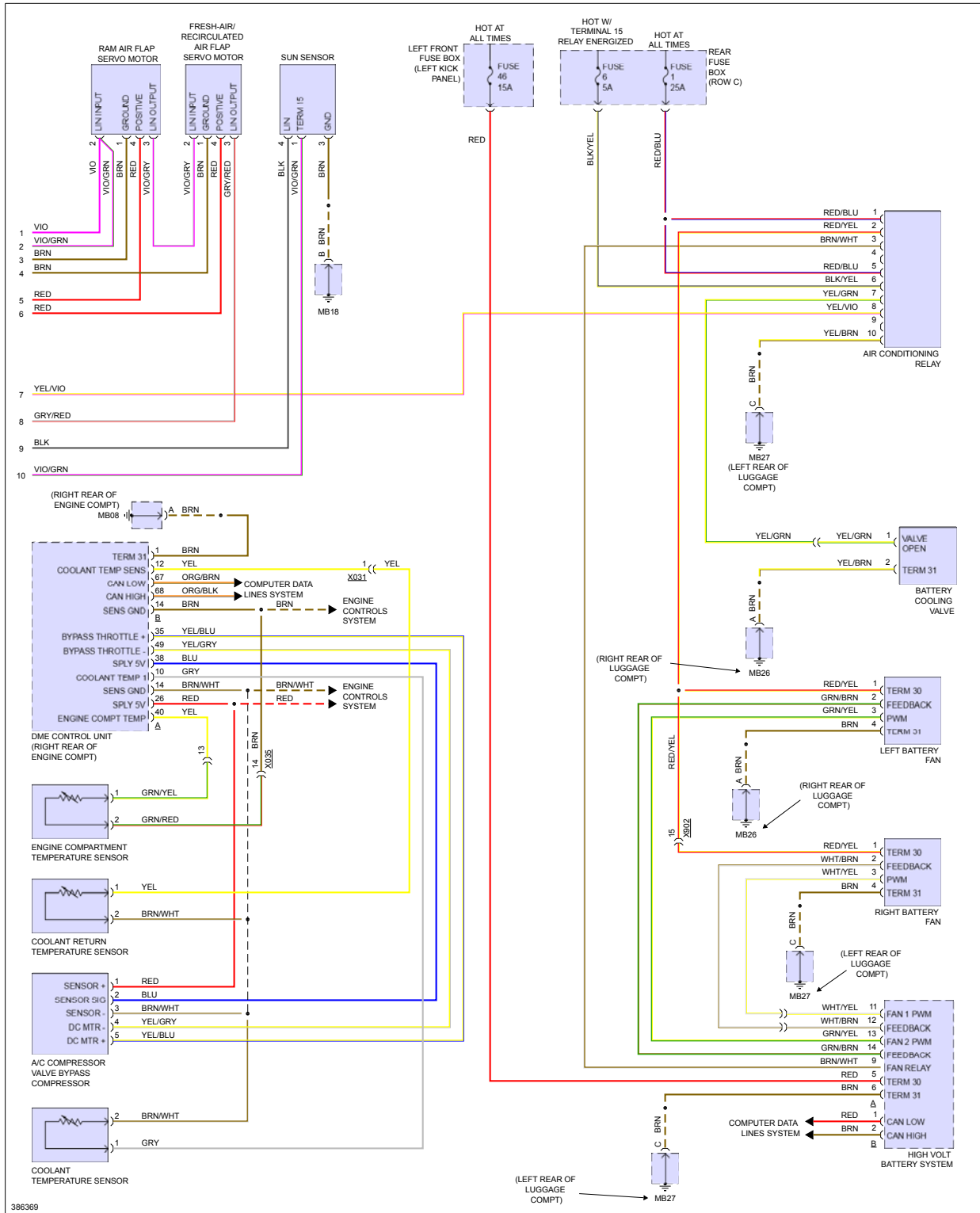

Fig 5: Automatic A/C Circuit, Hybrid (1 of 4)

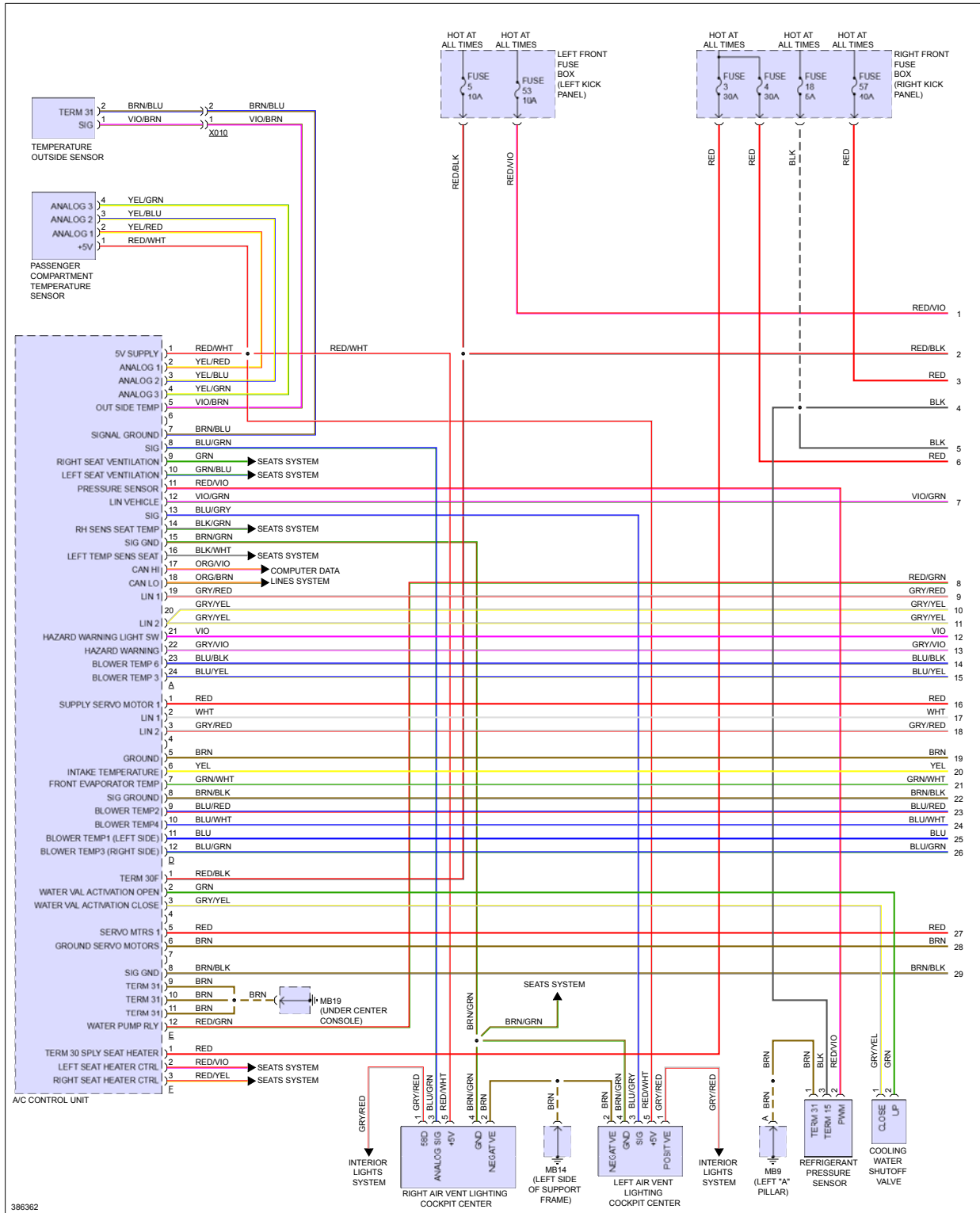

Fig 6: Automatic A/C Circuit, Hybrid (2 of 4)

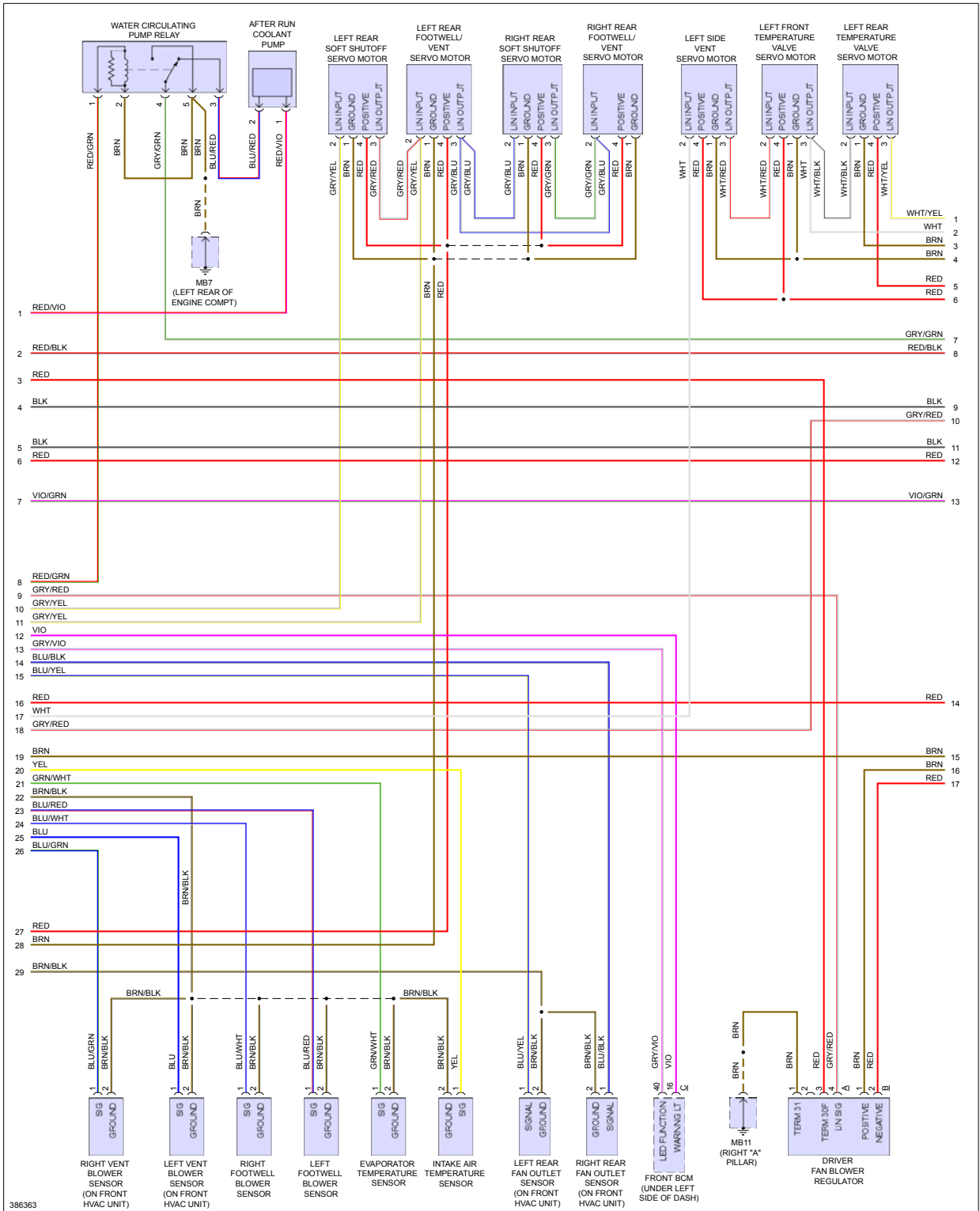



Fig 7: Automatic A/C Circuit, Hybrid (3 of 4)

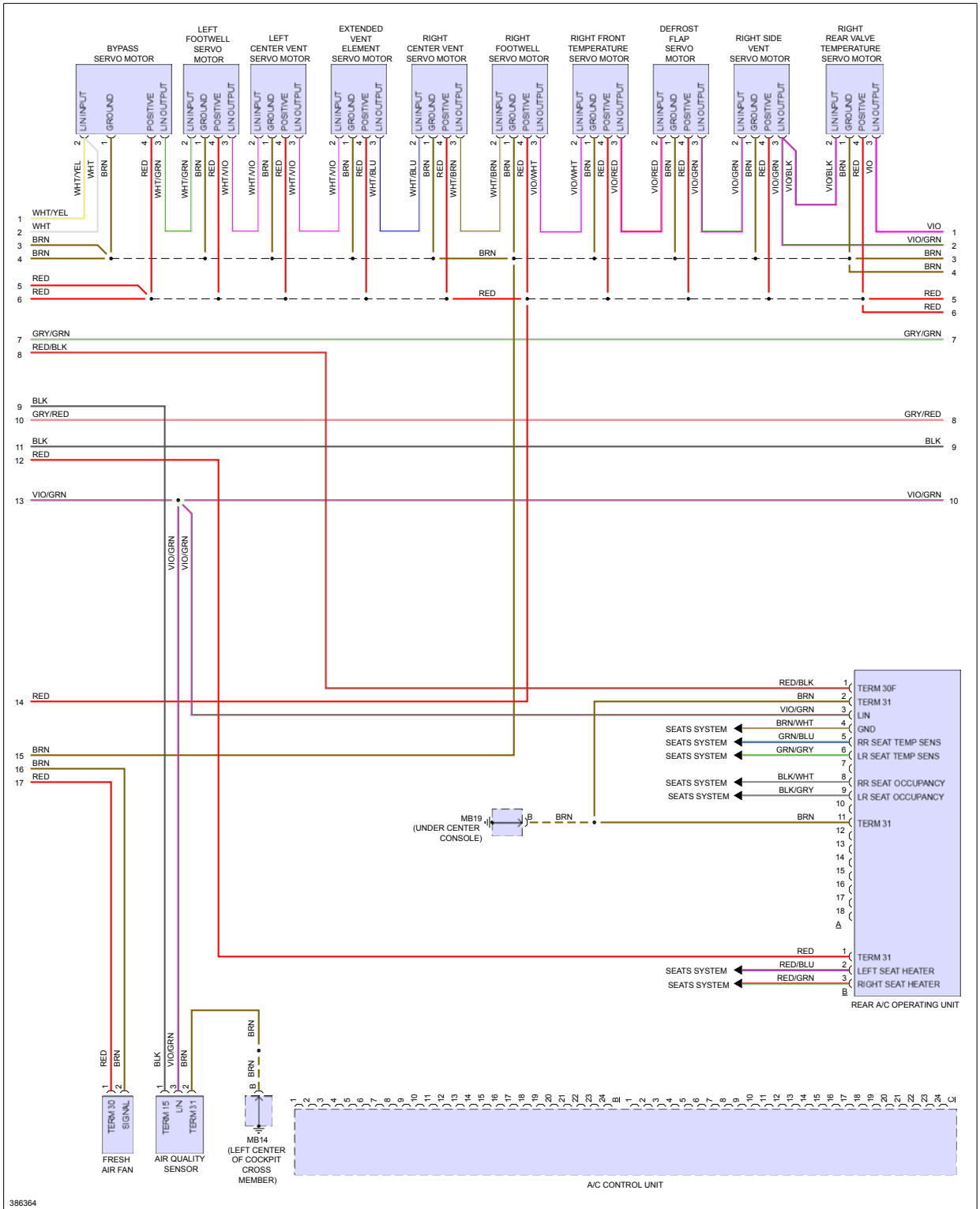
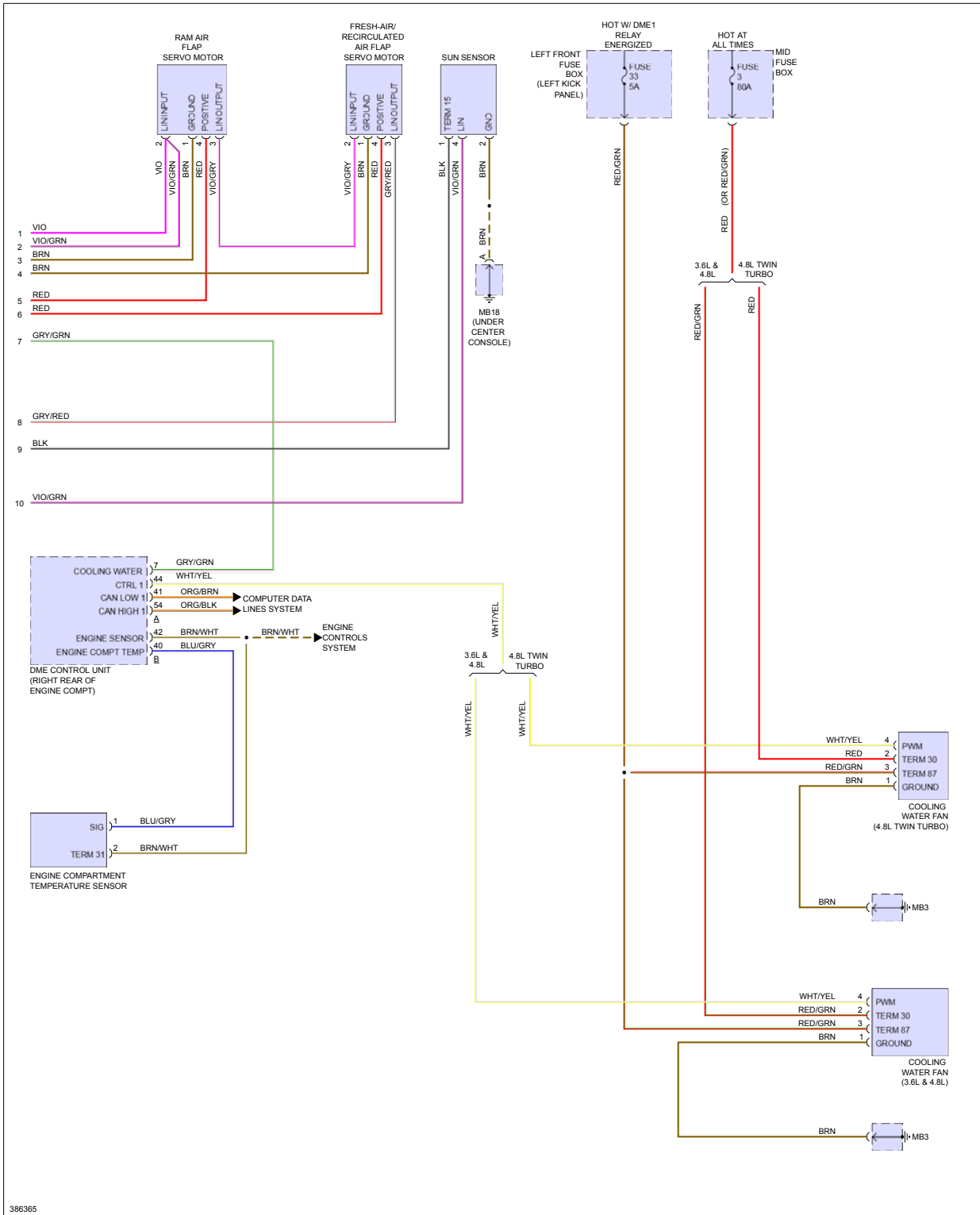
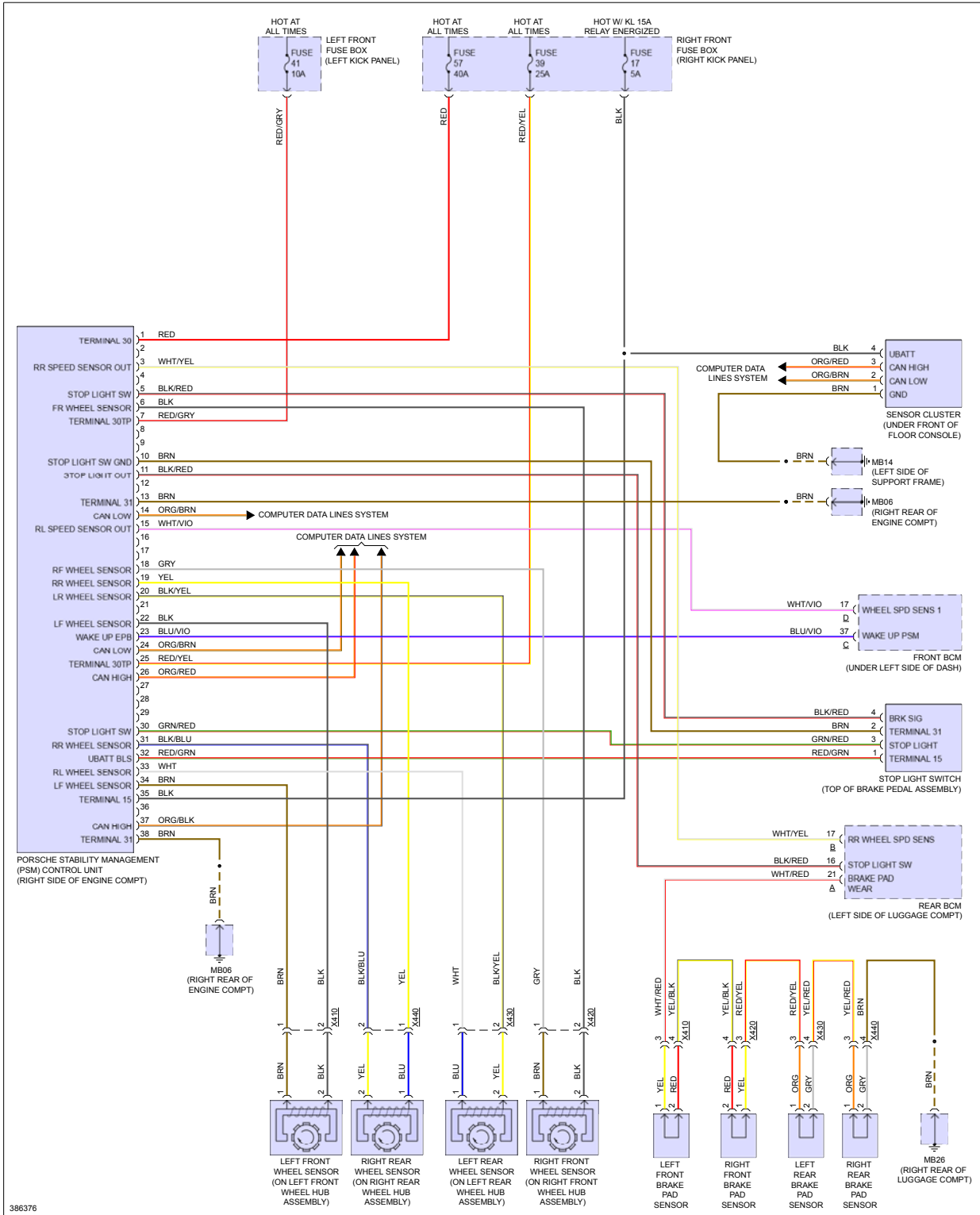

Fig 8: Automatic A/C Circuit, Hybrid (4 of 4)



# ANTI-LOCK BRAKES

Fig 1: Anti-lock Brakes Circuit



# ANTI-THEFT

Fig 1: Anti-theft Circuit

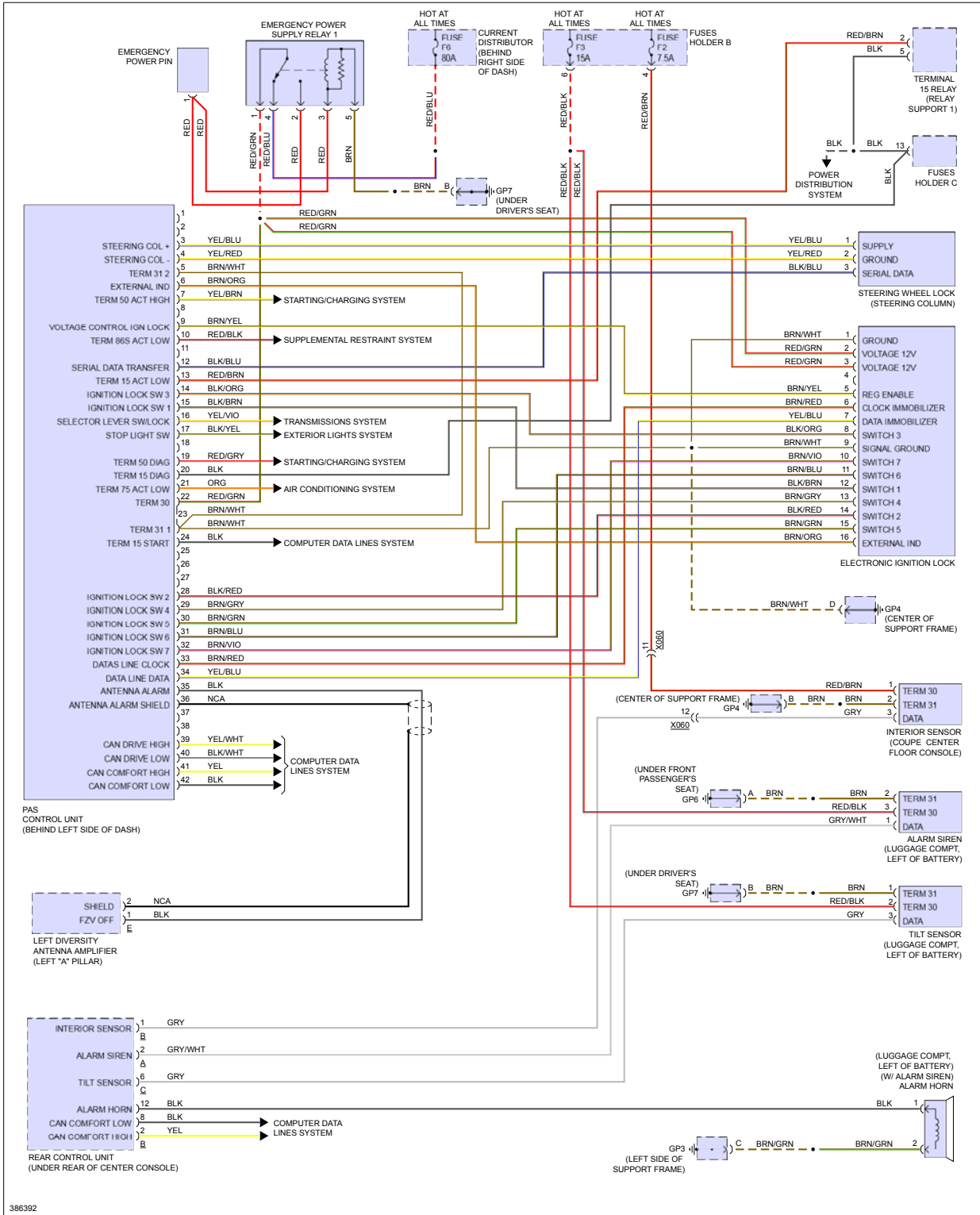

# BODY CONTROL MODULES

Fig 1: Front Controller Circuit

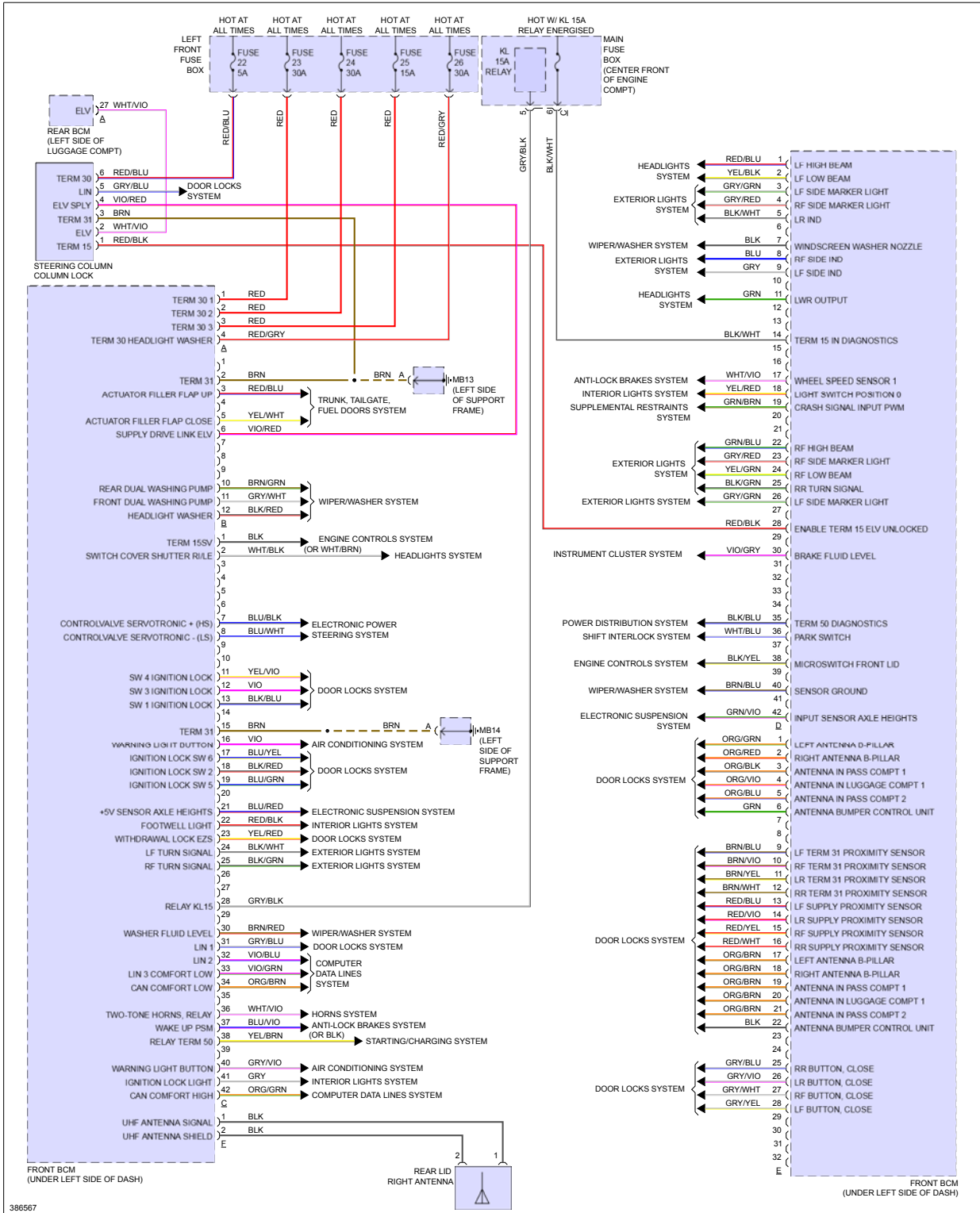
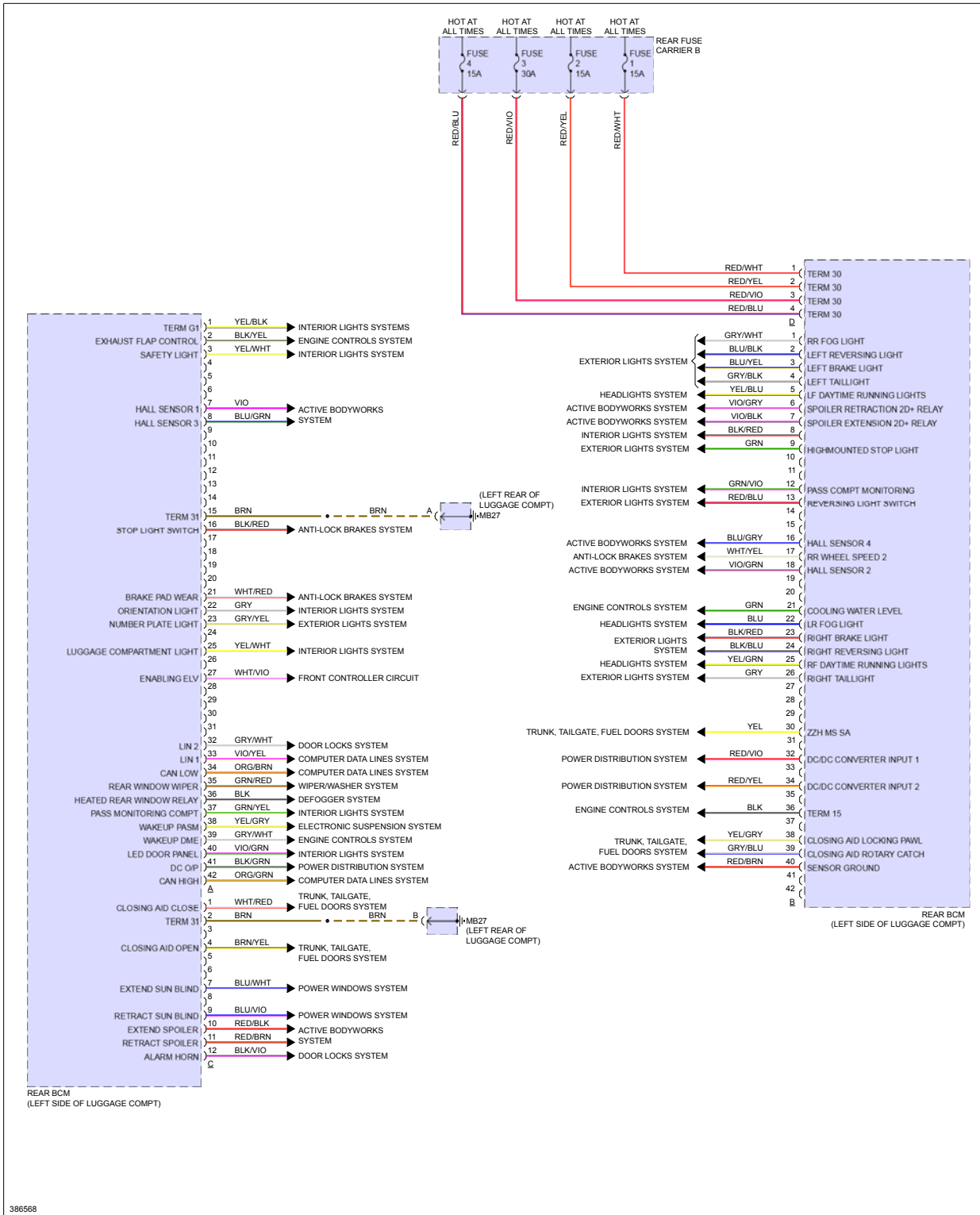

Fig 2: Rear Control Unit Circuit



# COMPUTER DATA LINES

Fig 1: Computer Data Lines Circuit (1 of 3)

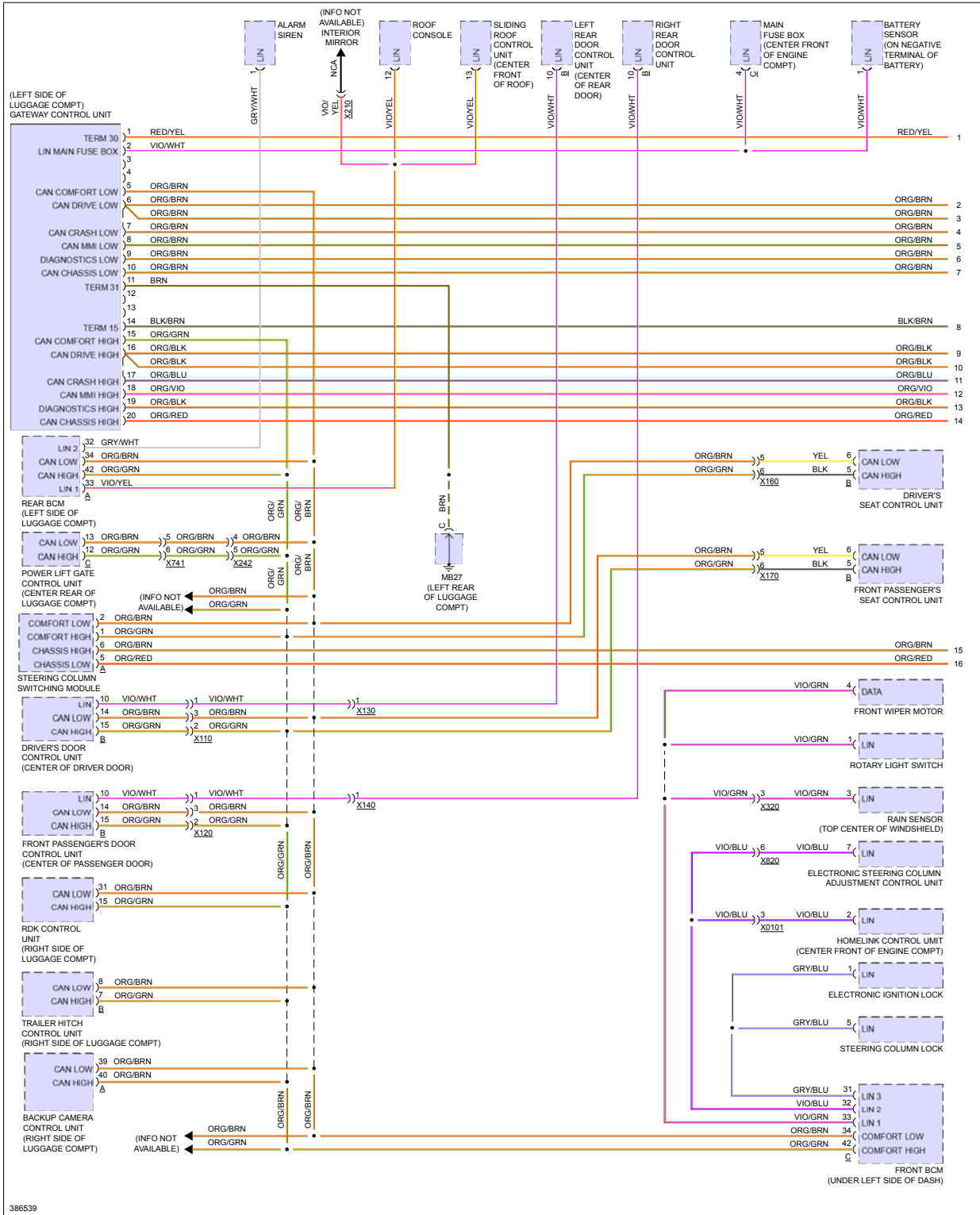

Fig 2: Computer Data Lines Circuit (2 of 3)

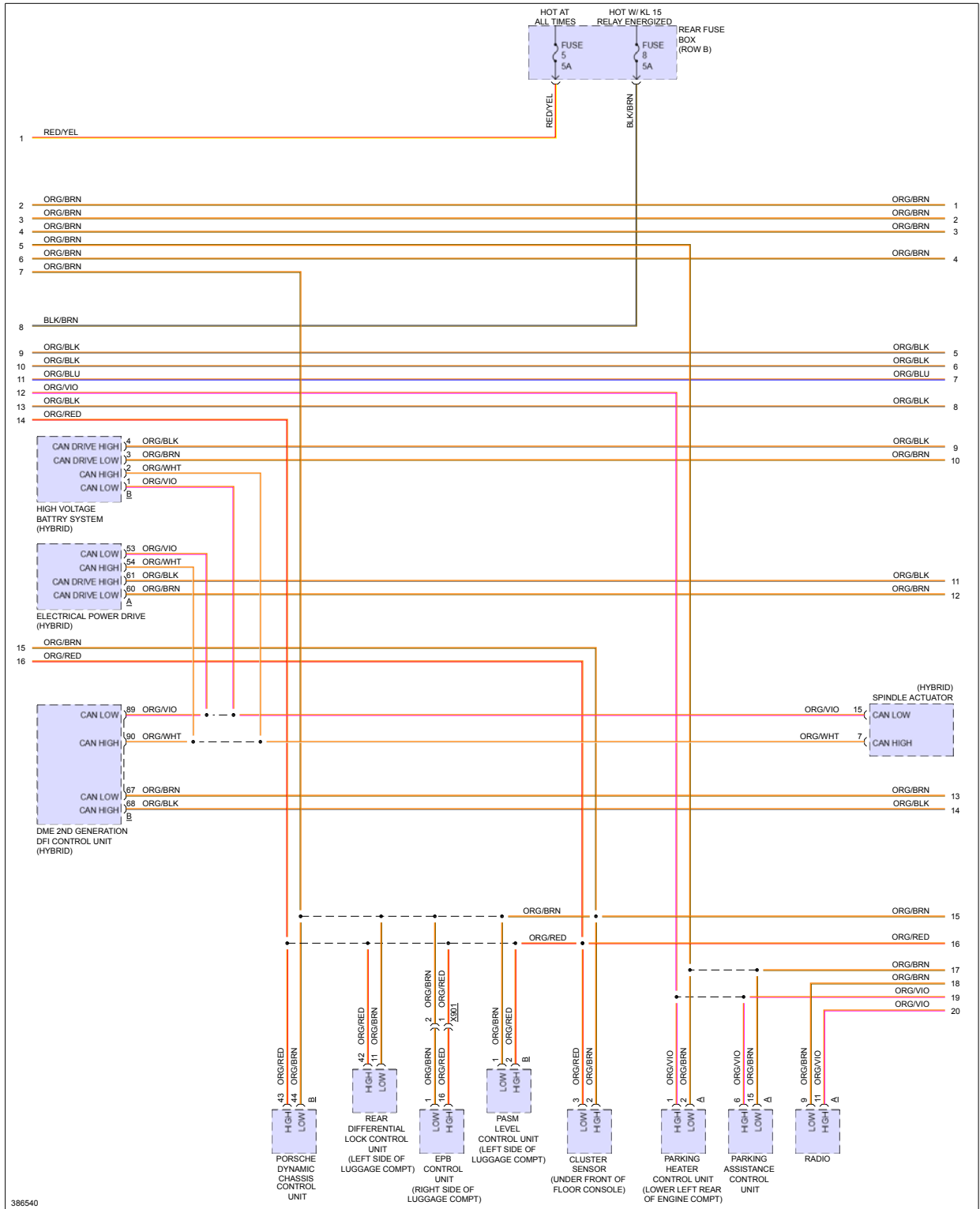
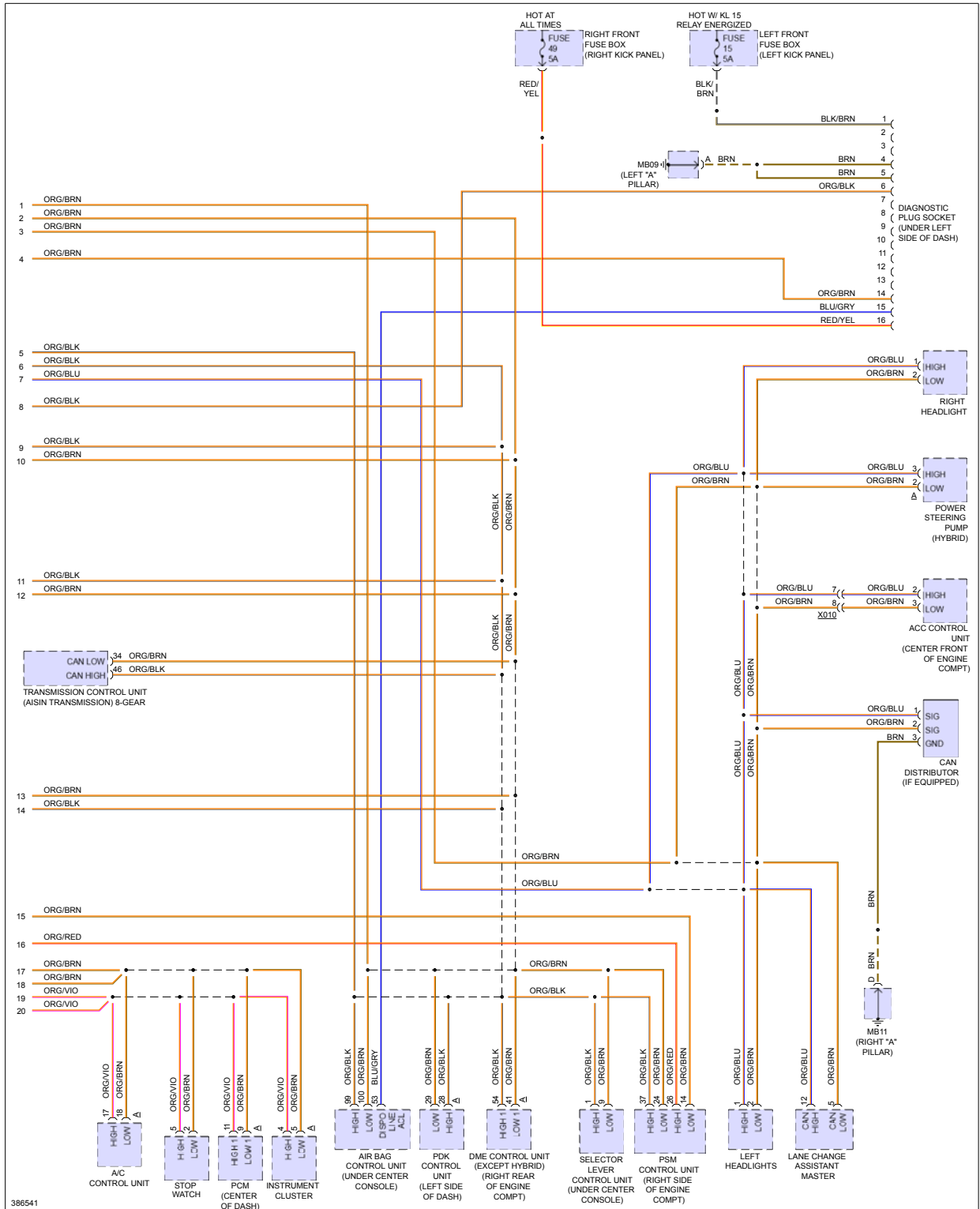



Fig 3: Computer Data Lines Circuit (3 of 3)



# COOLING FAN

Fig 1: Cooling Fan Circuit, Except Hybrid

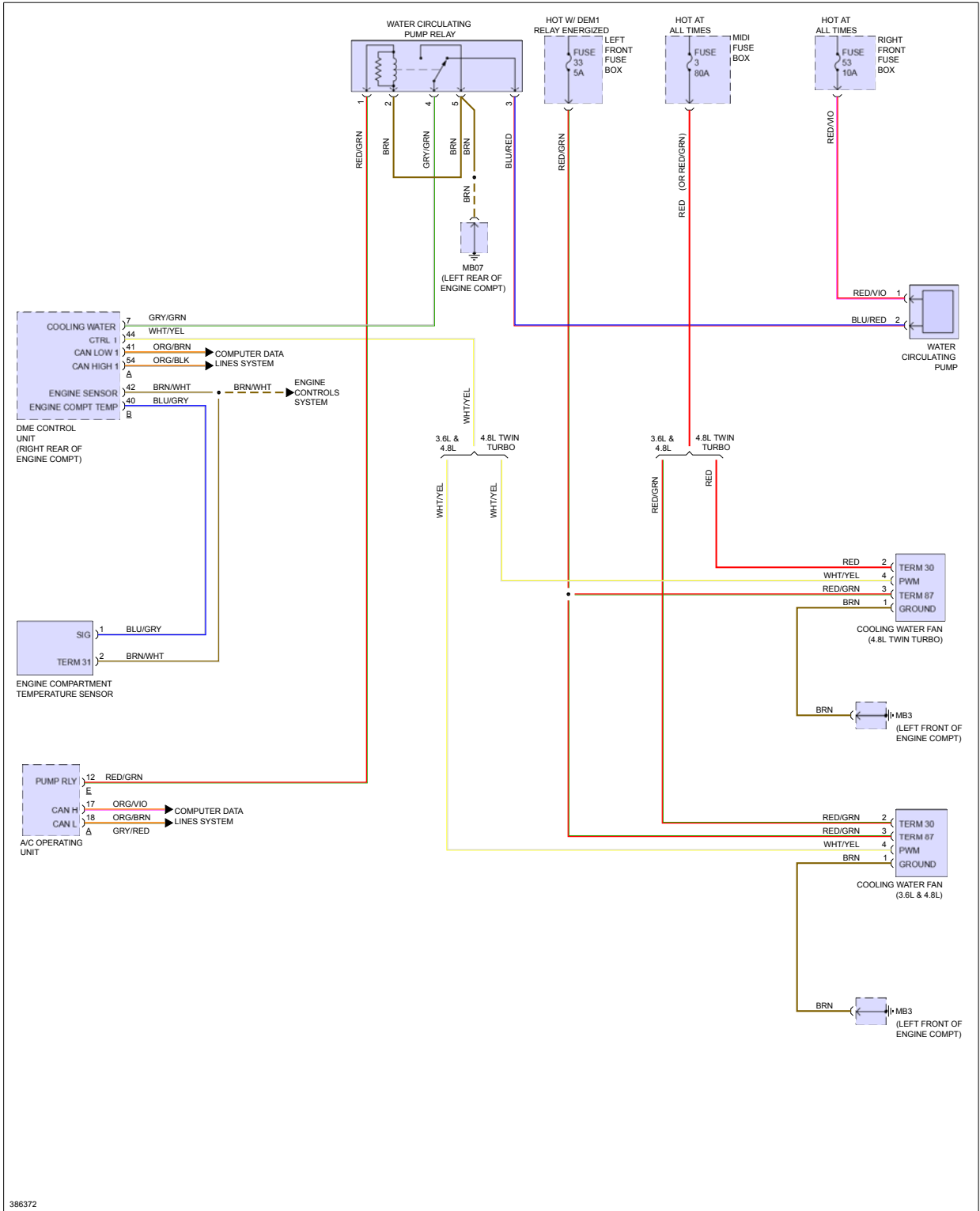
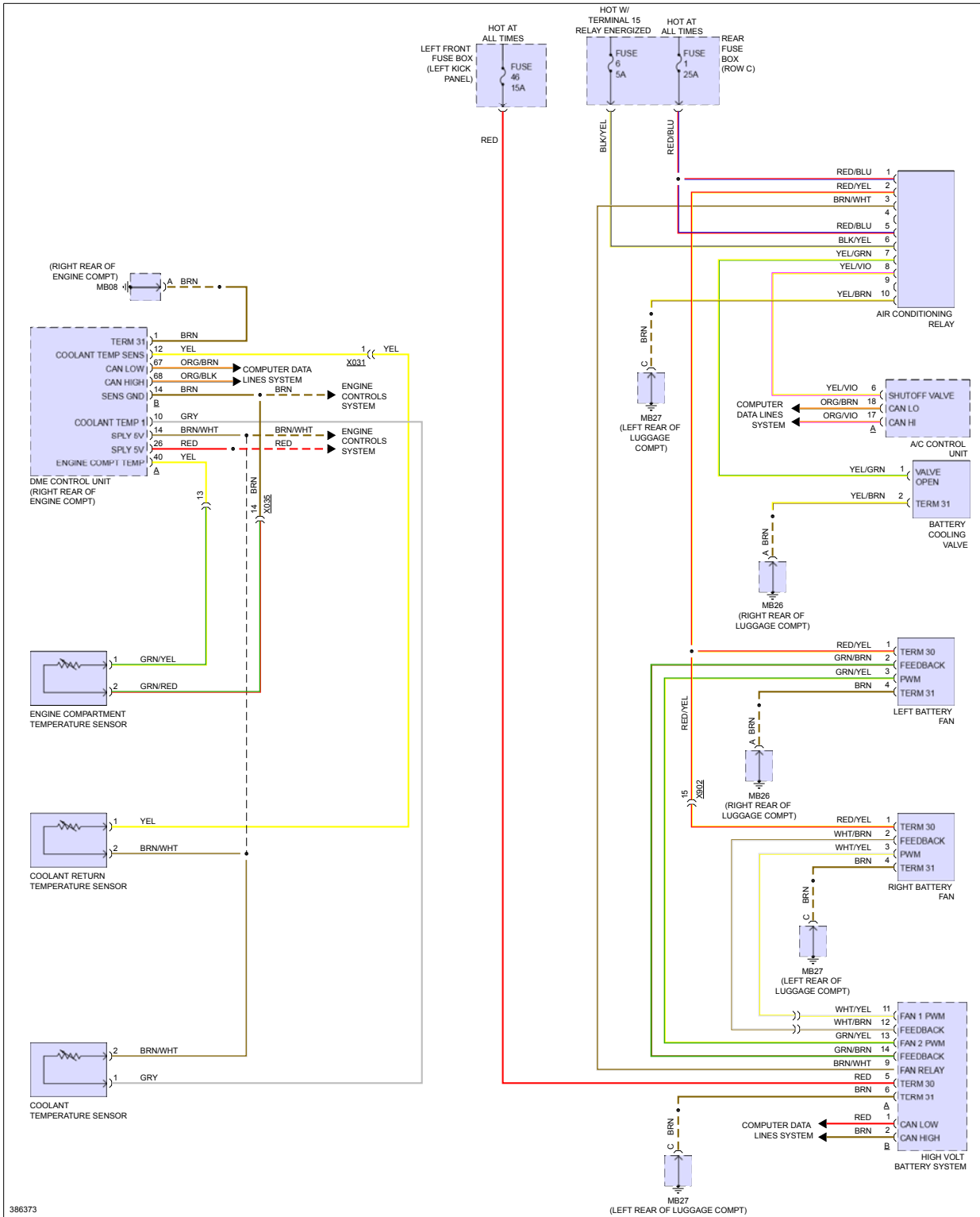

Fig 2: Cooling Fan Circuit, Hybrid



# CRUISE CONTROL

Fig 1: Cruise Control Circuit, Except Hybrid

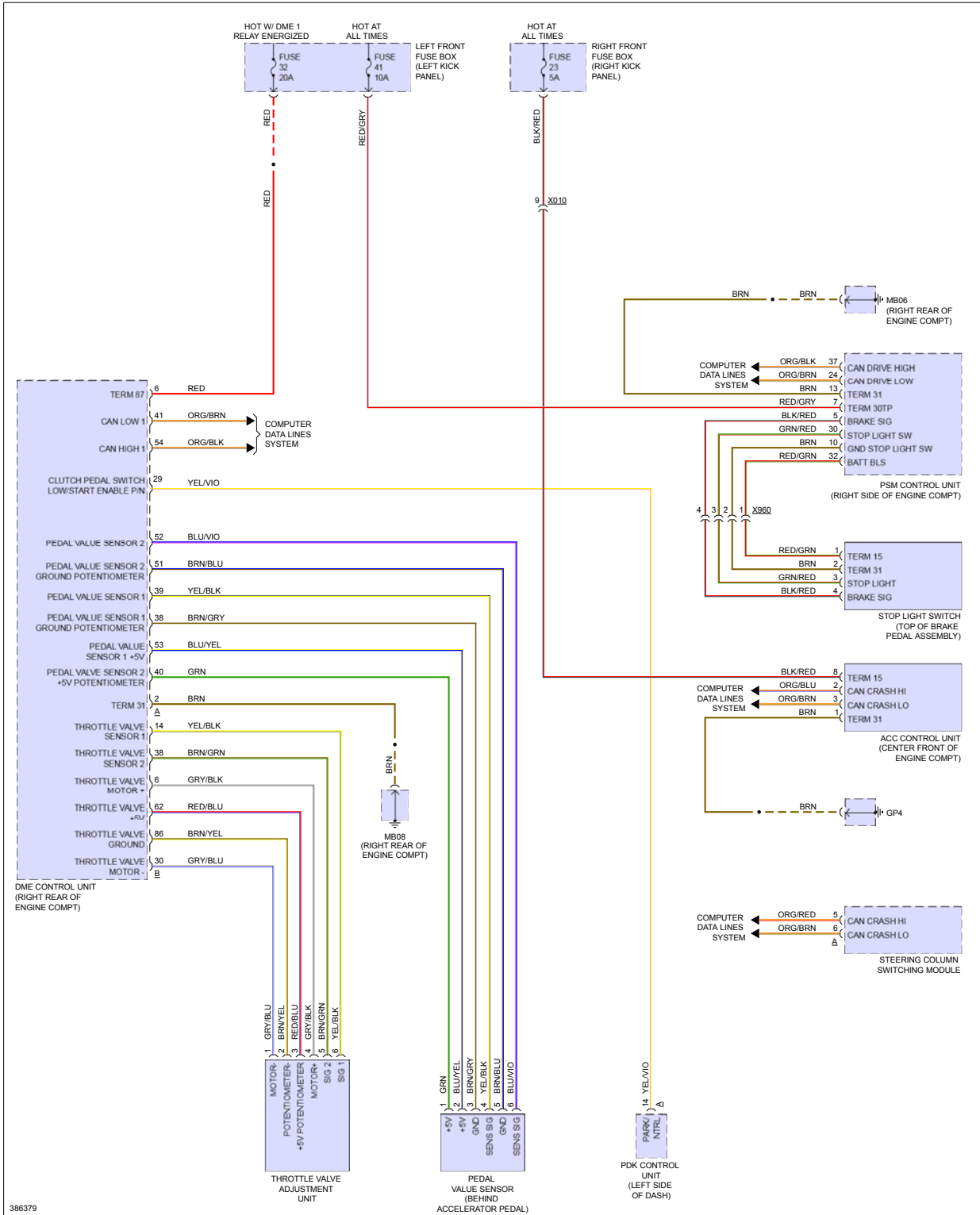
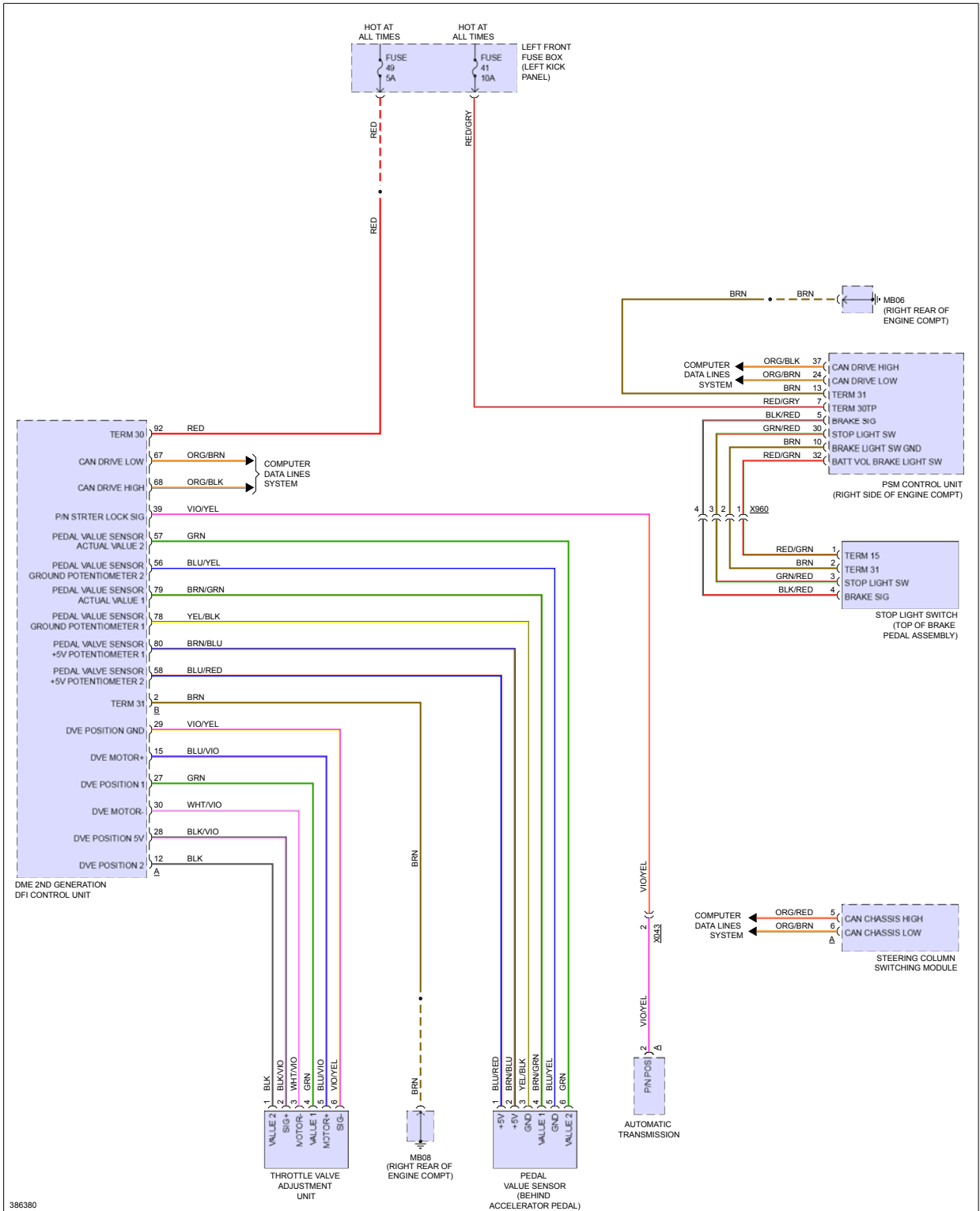

Fig 2: Cruise Control Circuit, Hybrid



# DEFOGGERS

Fig 1: Defogger Circuit

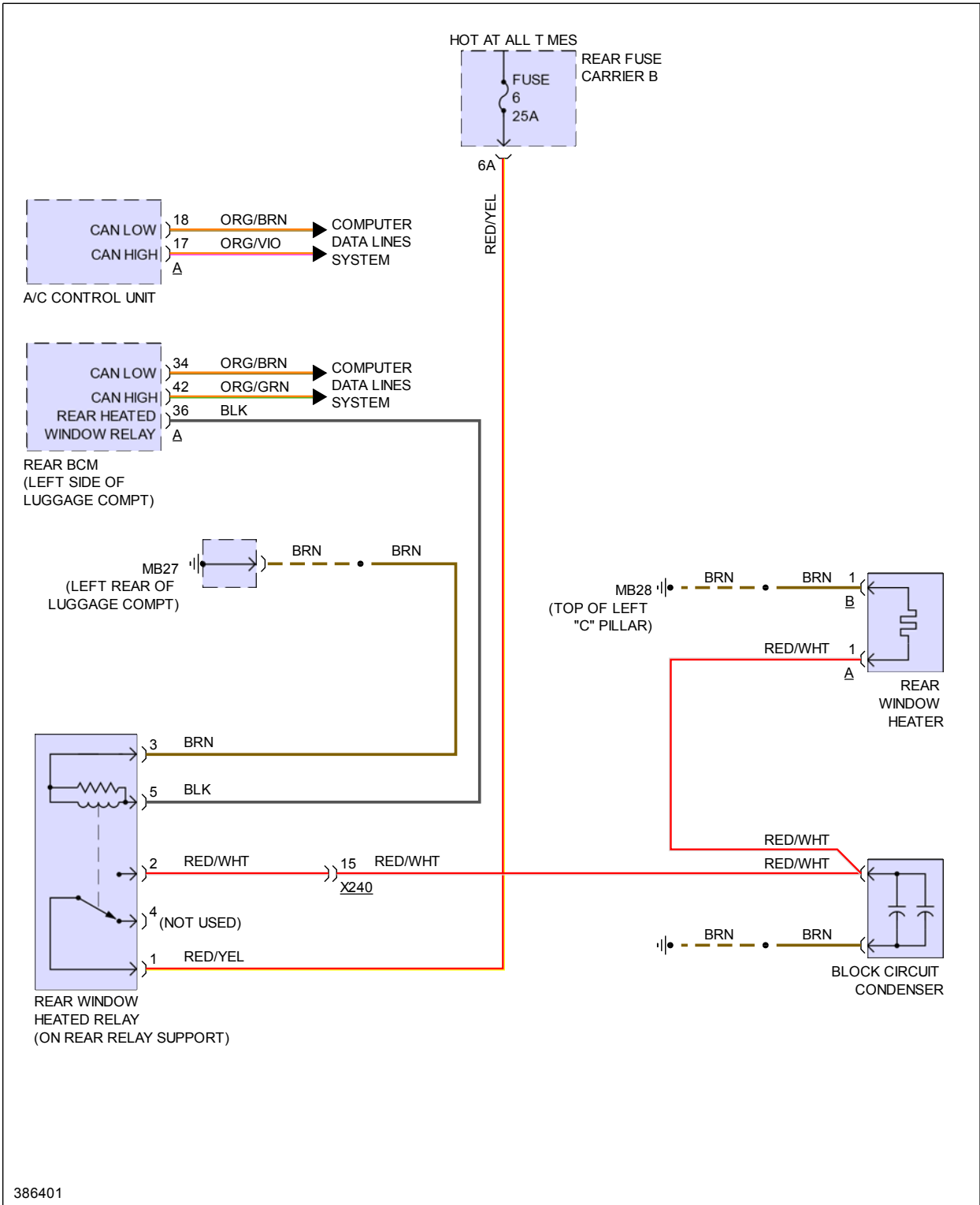
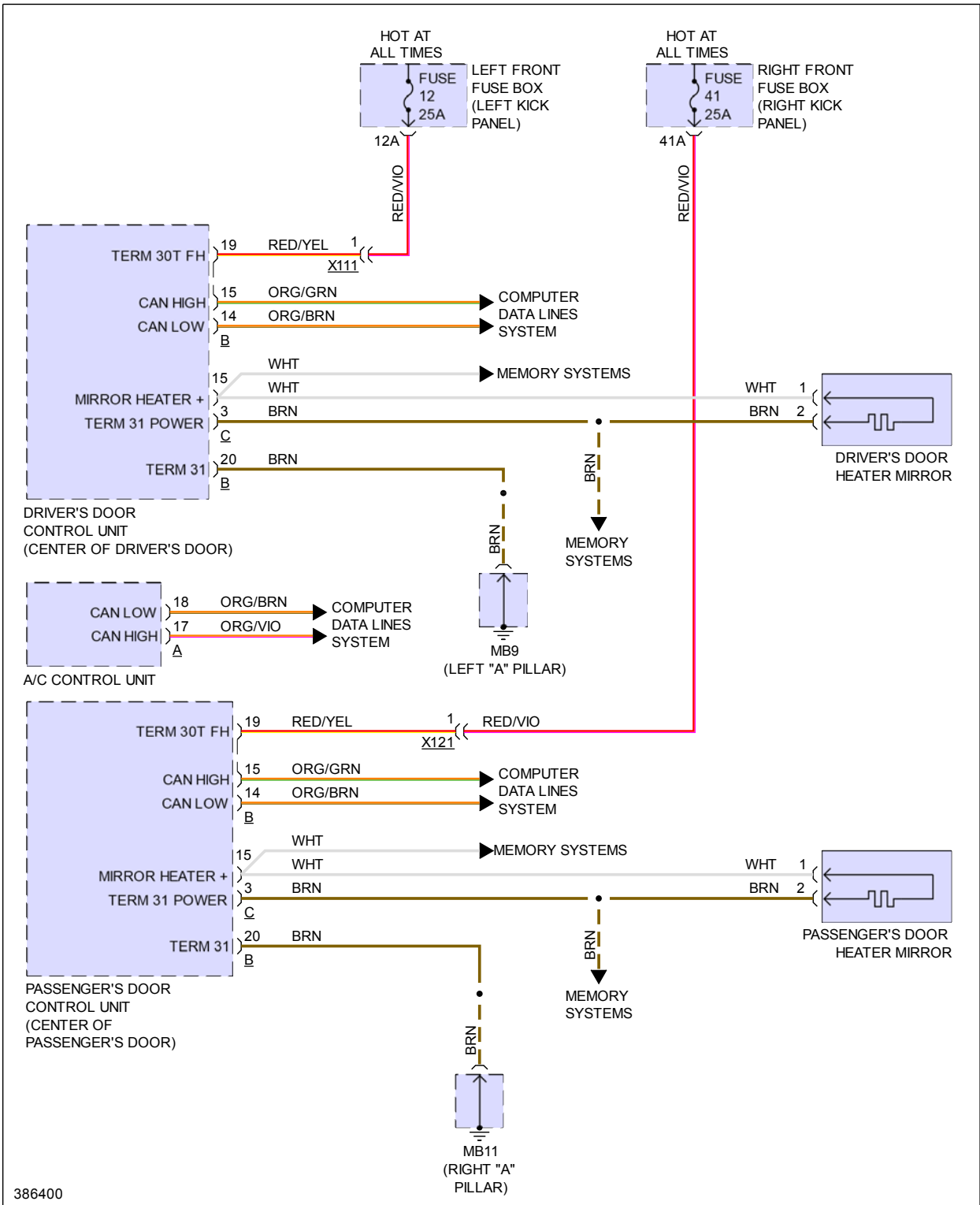

Fig 2: Heated Mirrors Circuit



# ELECTRONIC POWER STEERING

Fig 1: Electronic Power Steering Circuit

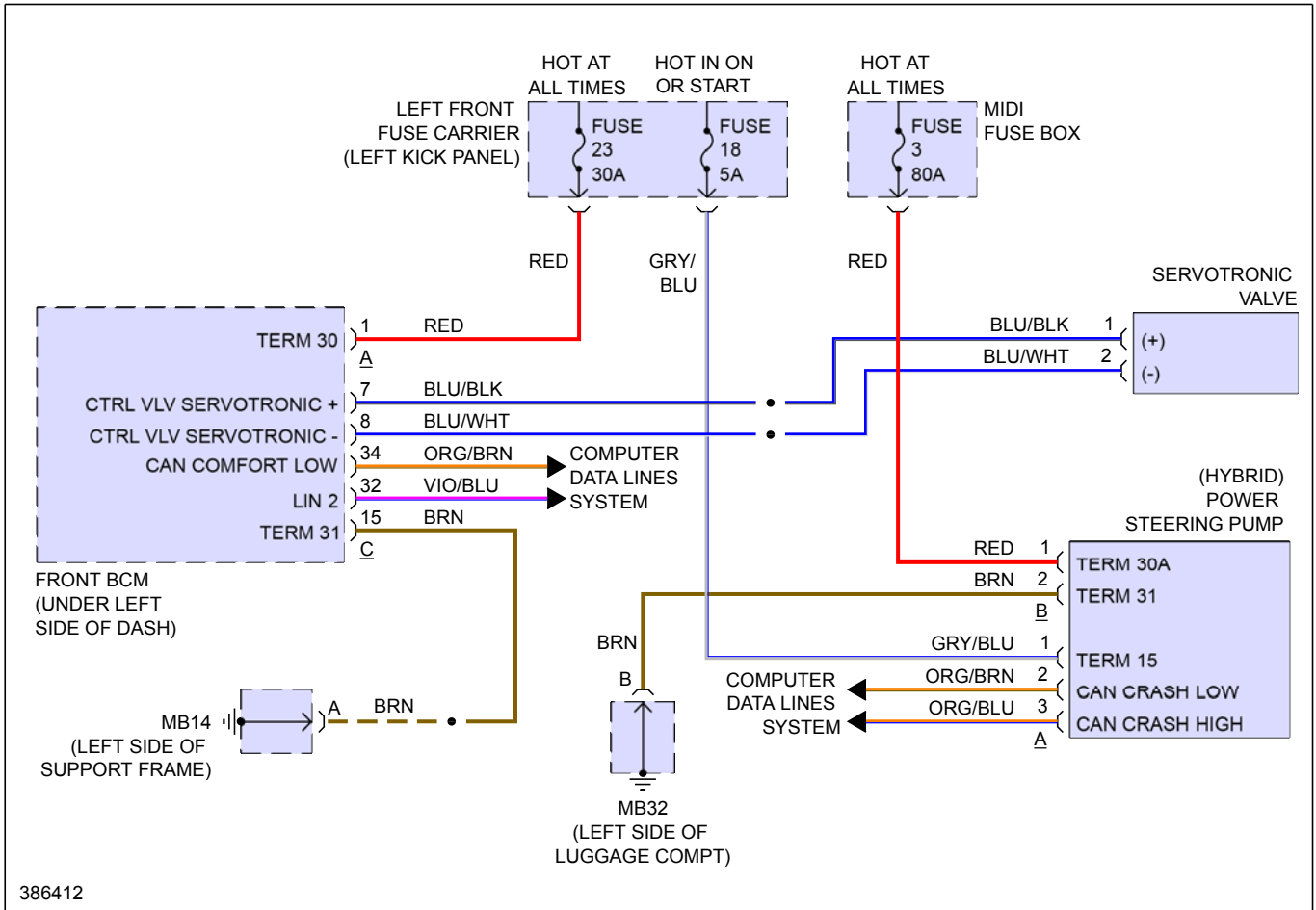
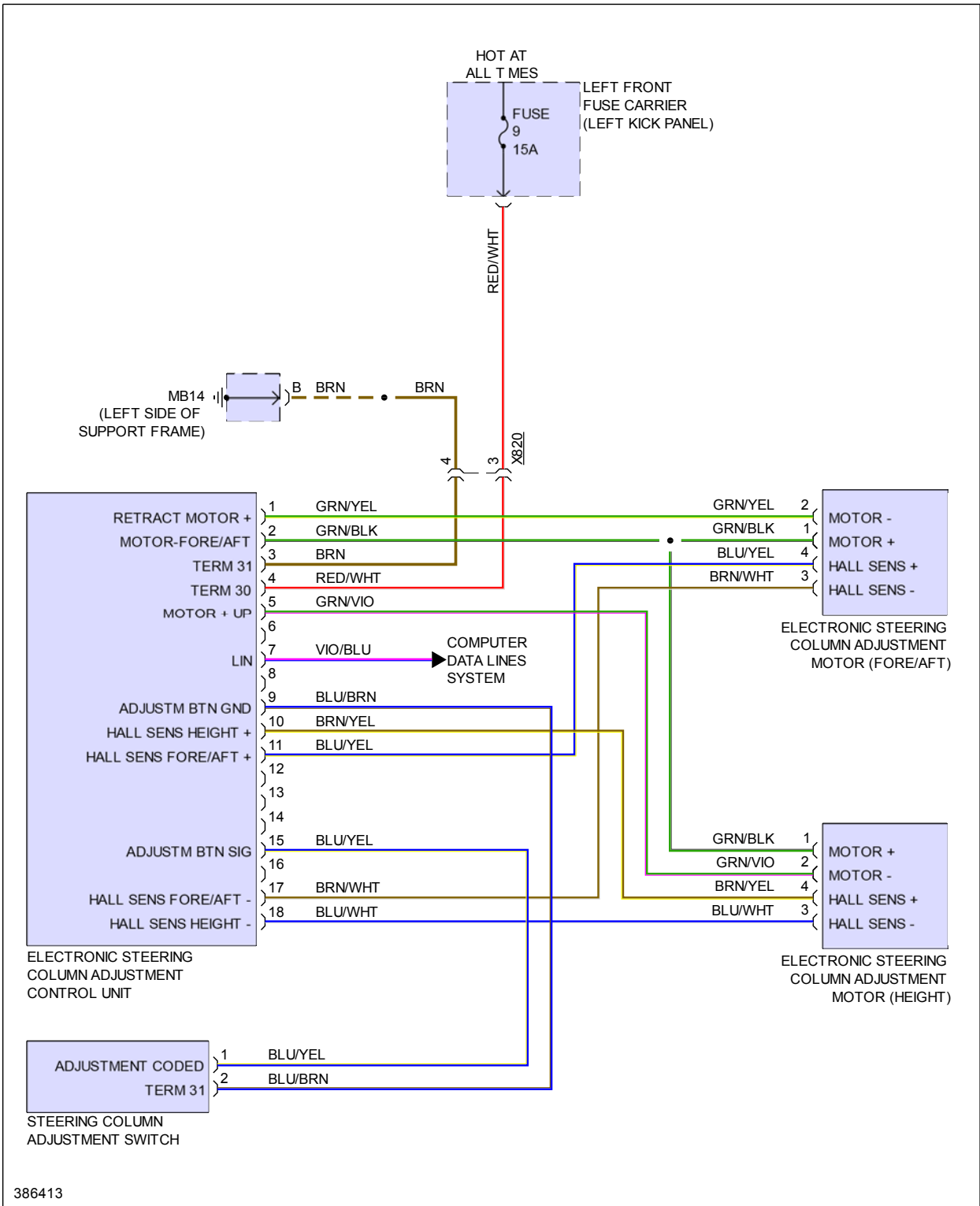



Fig 2: Power Tilt Steering Column Circuit



# ELECTRONIC SUSPENSION

Fig 1: Dynamic Chassis Control Circuit

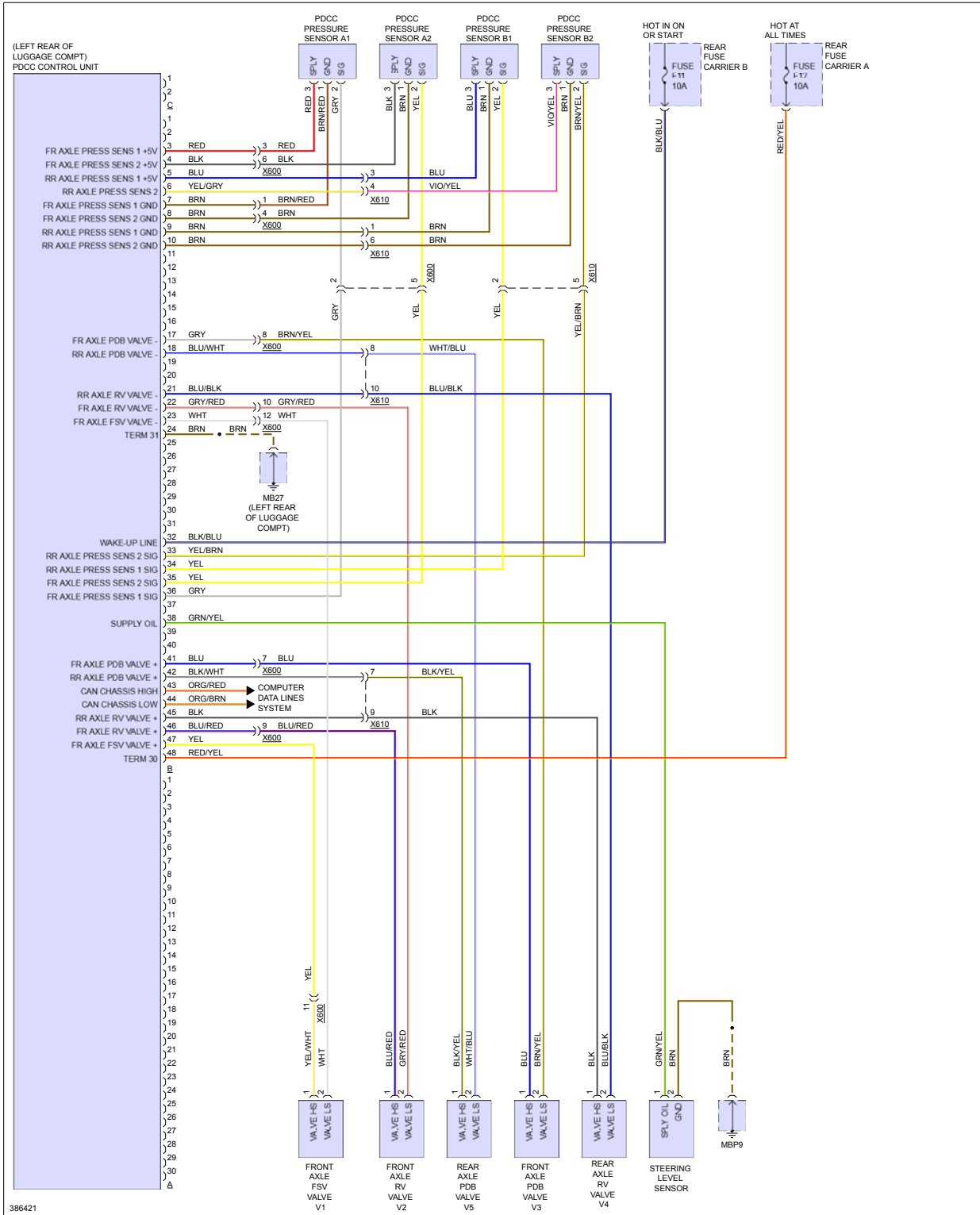

Fig 2: Electronic Level Control Circuit (1 of 2)

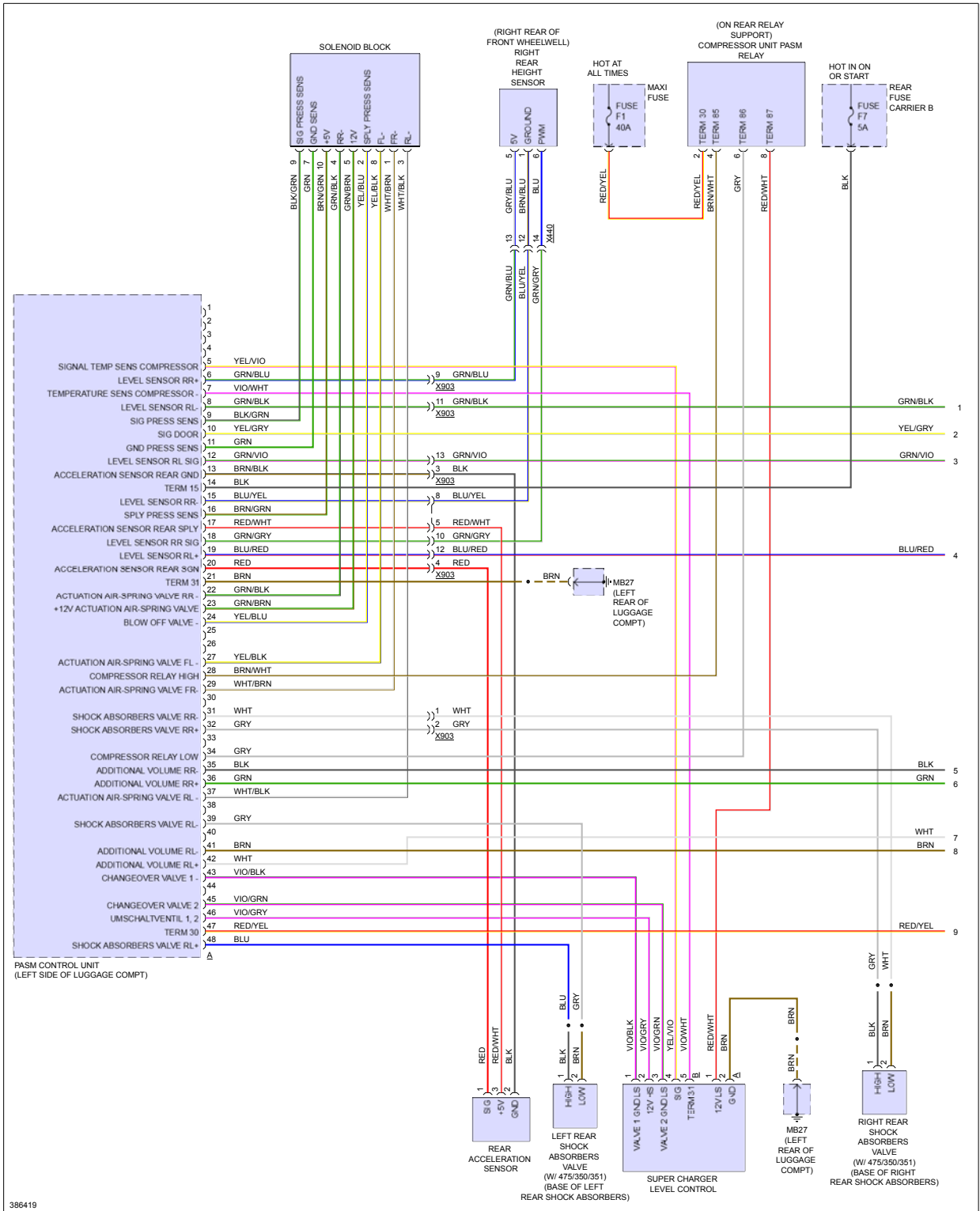
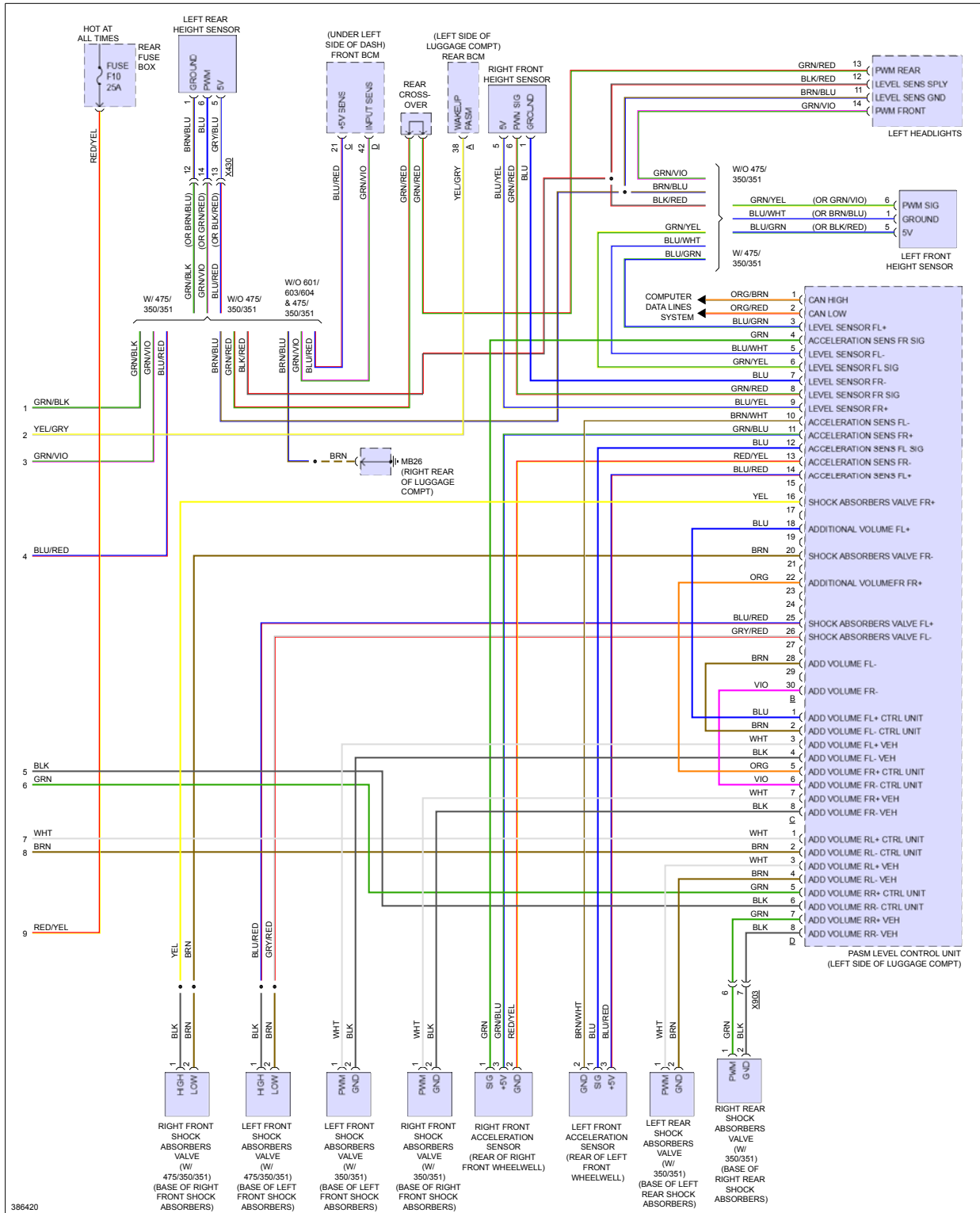

Fig 3: Electronic Level Control Circuit (2 of 2)



# ENGINE PERFORMANCE > 3.0L HYBRID

Fig 1: 3.0L Hybrid, Engine Performance Circuit (1 of 7)

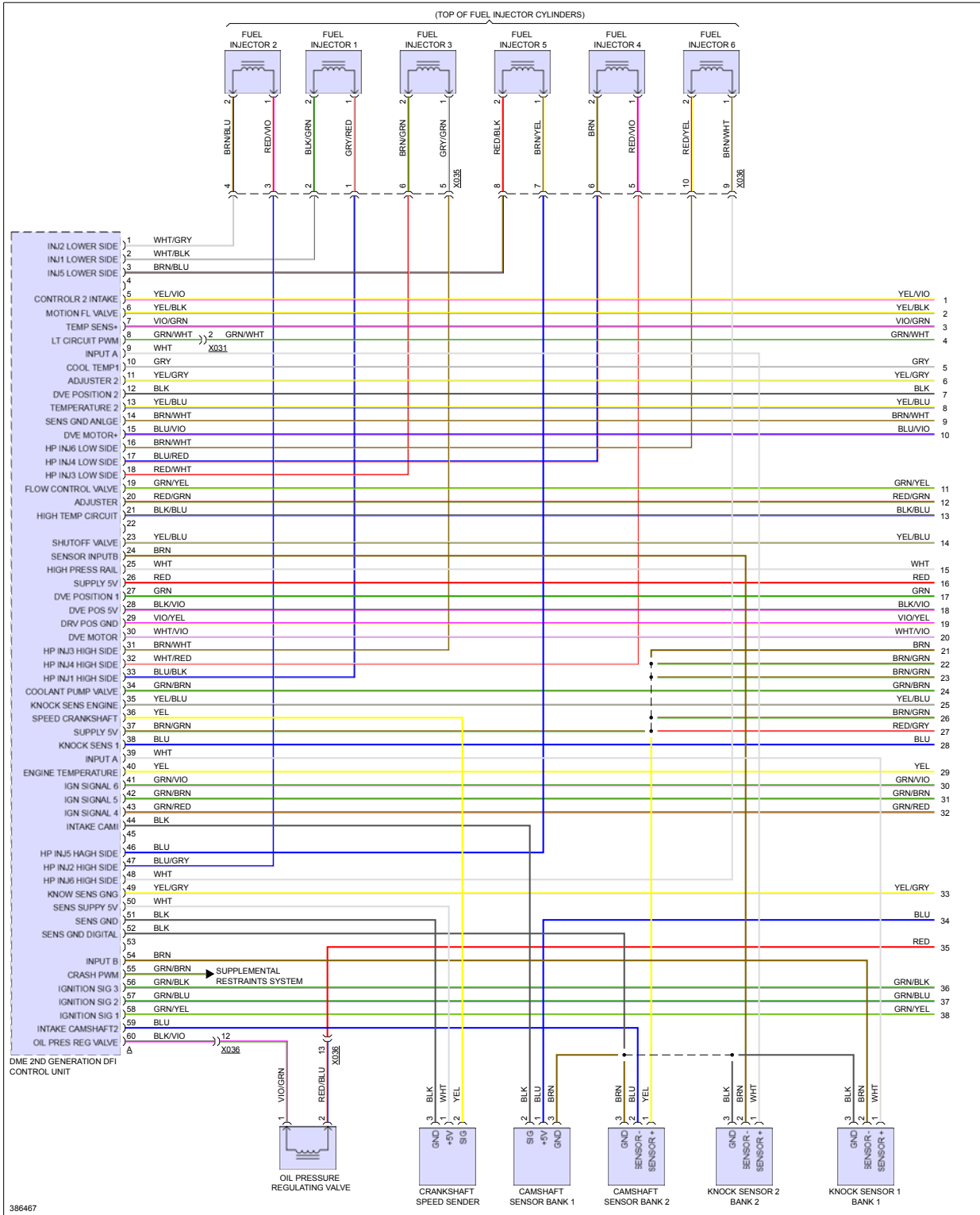

Fig 2: 3.0L Hybrid, Engine Performance Circuit (2 of 7)

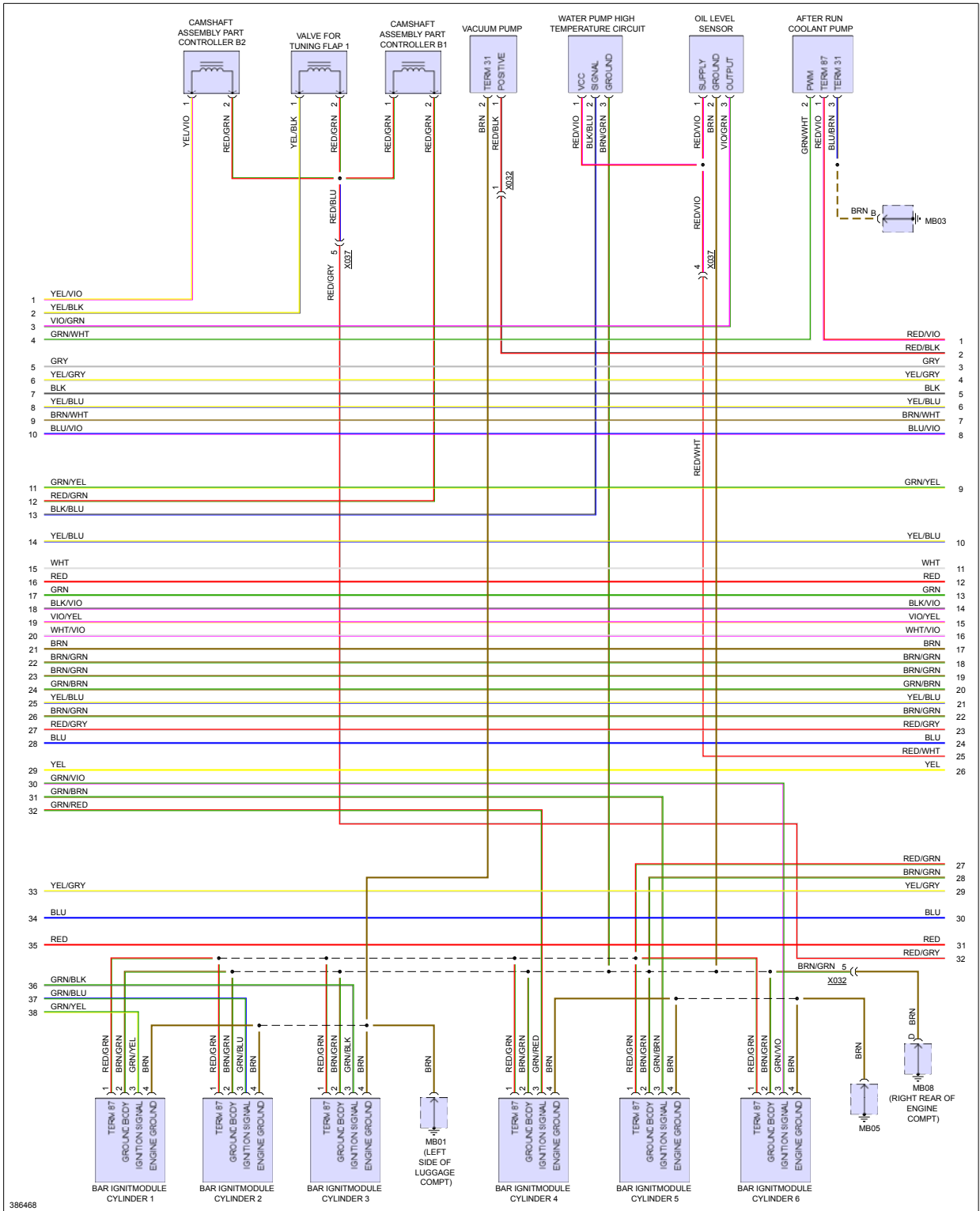

Fig 3: 3.0L Hybrid, Engine Performance Circuit (3 of 7)

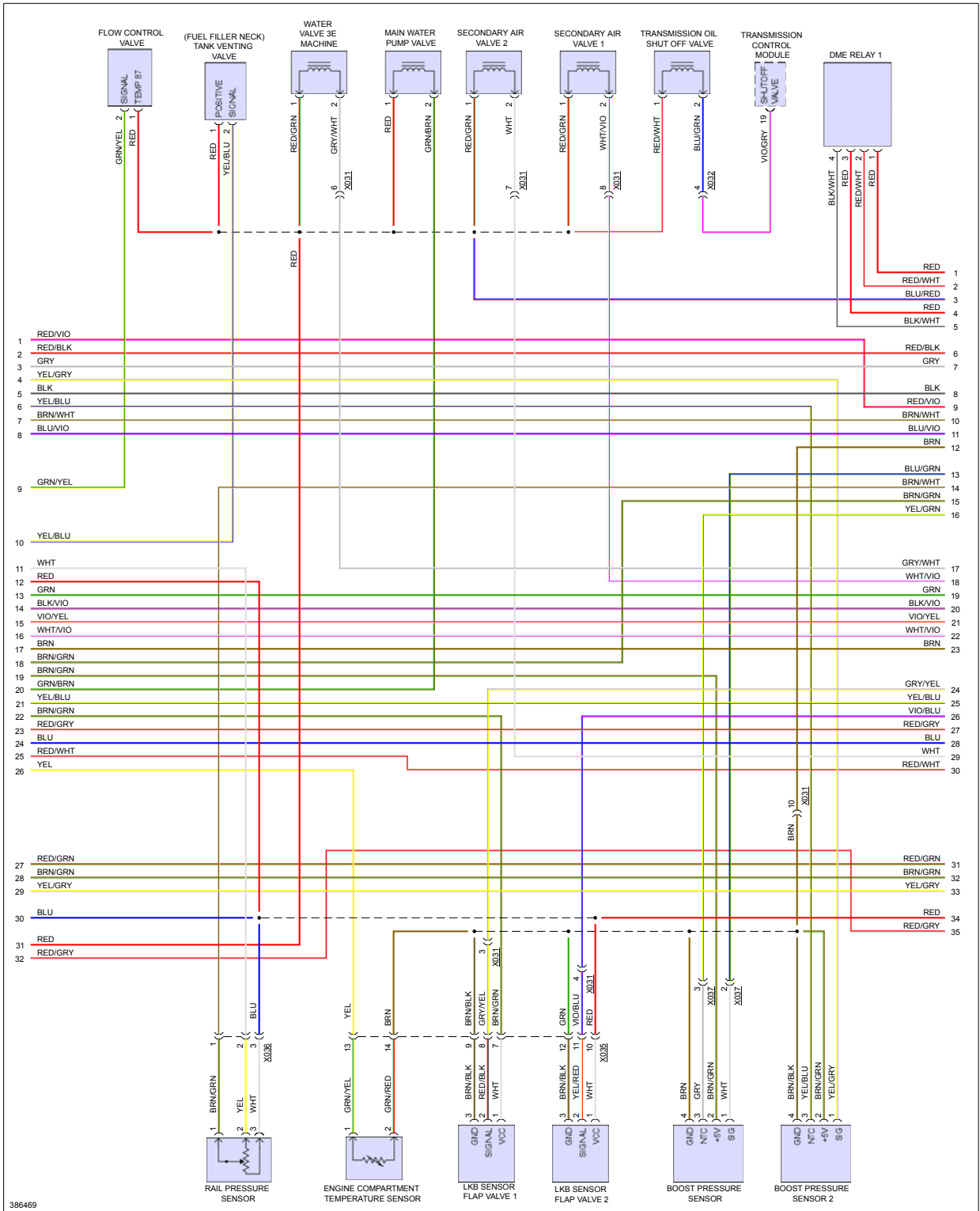

Fig 4: 3.0L Hybrid, Engine Performance Circuit (4 of 7)

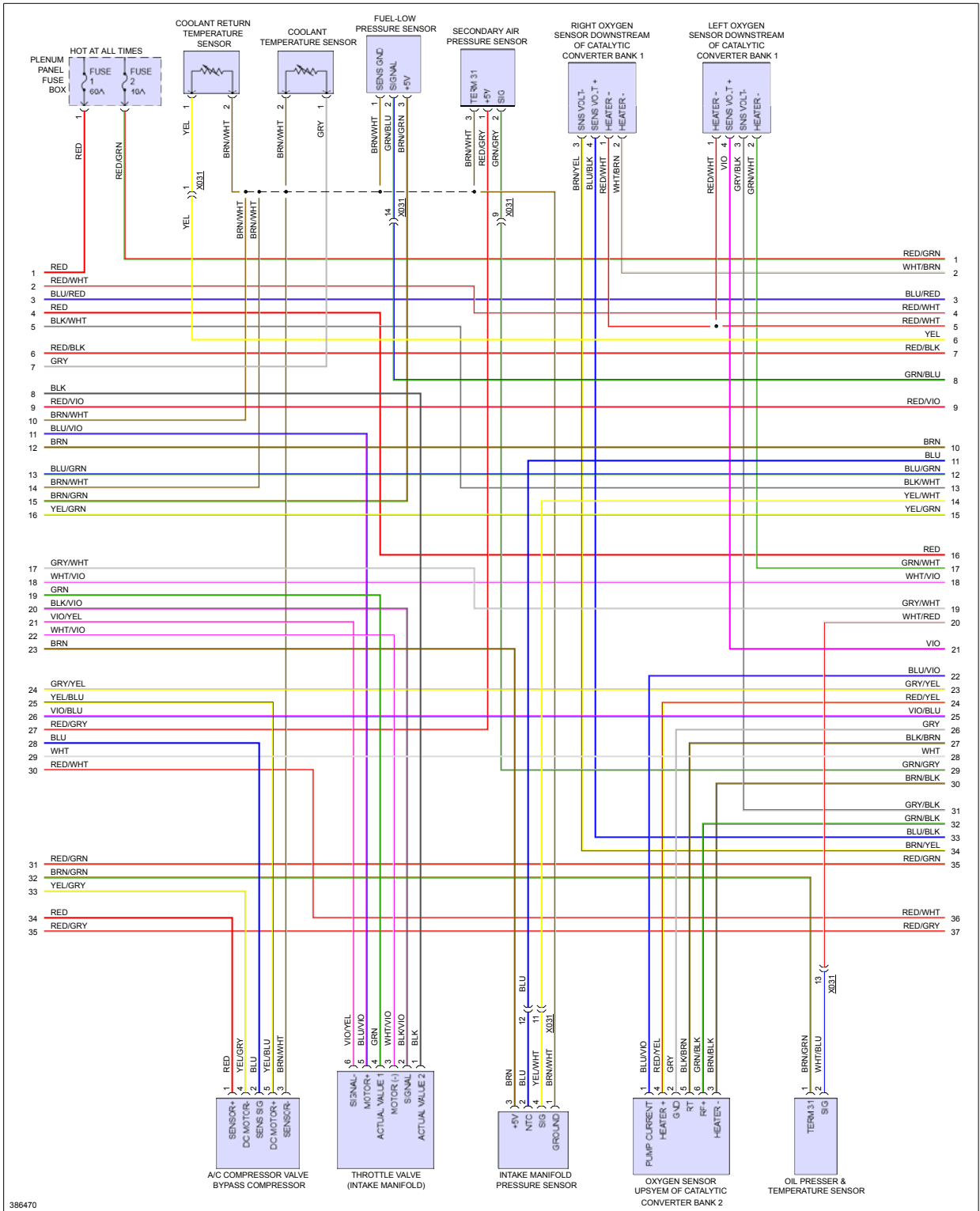
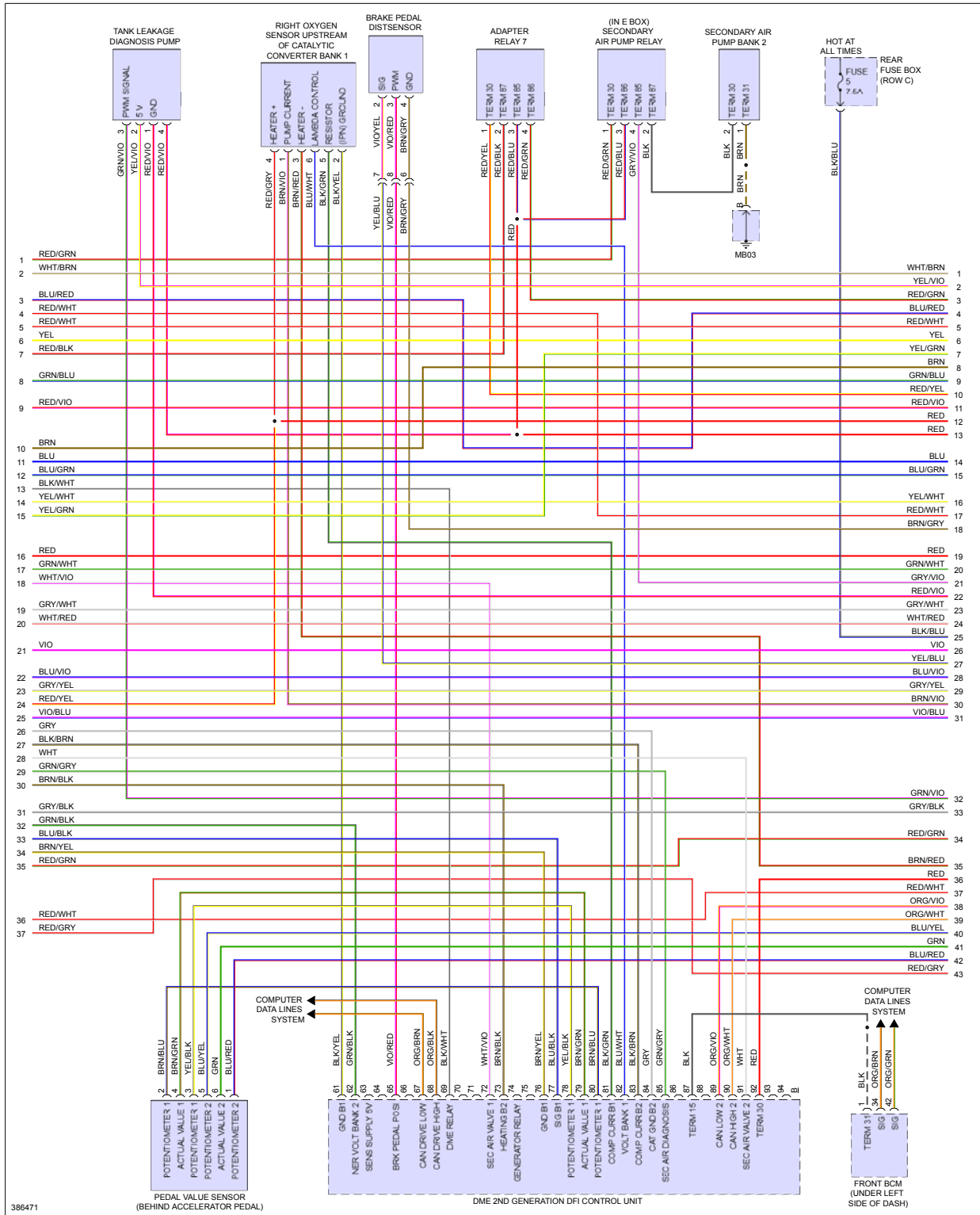



Fig 5: 3.0L Hybrid, Engine Performance Circuit (5 of 7)



386471

PEDAL VALUE SENSOR (BEHIND ACCELERATOR PEDAL)

DME 2ND GENERATION DFI CONTROL UNIT

FRONT BCM (UNDER LEFT SIDE OF DASH)

Fig 6: 3.0L Hybrid, Engine Performance Circuit (6 of 7)

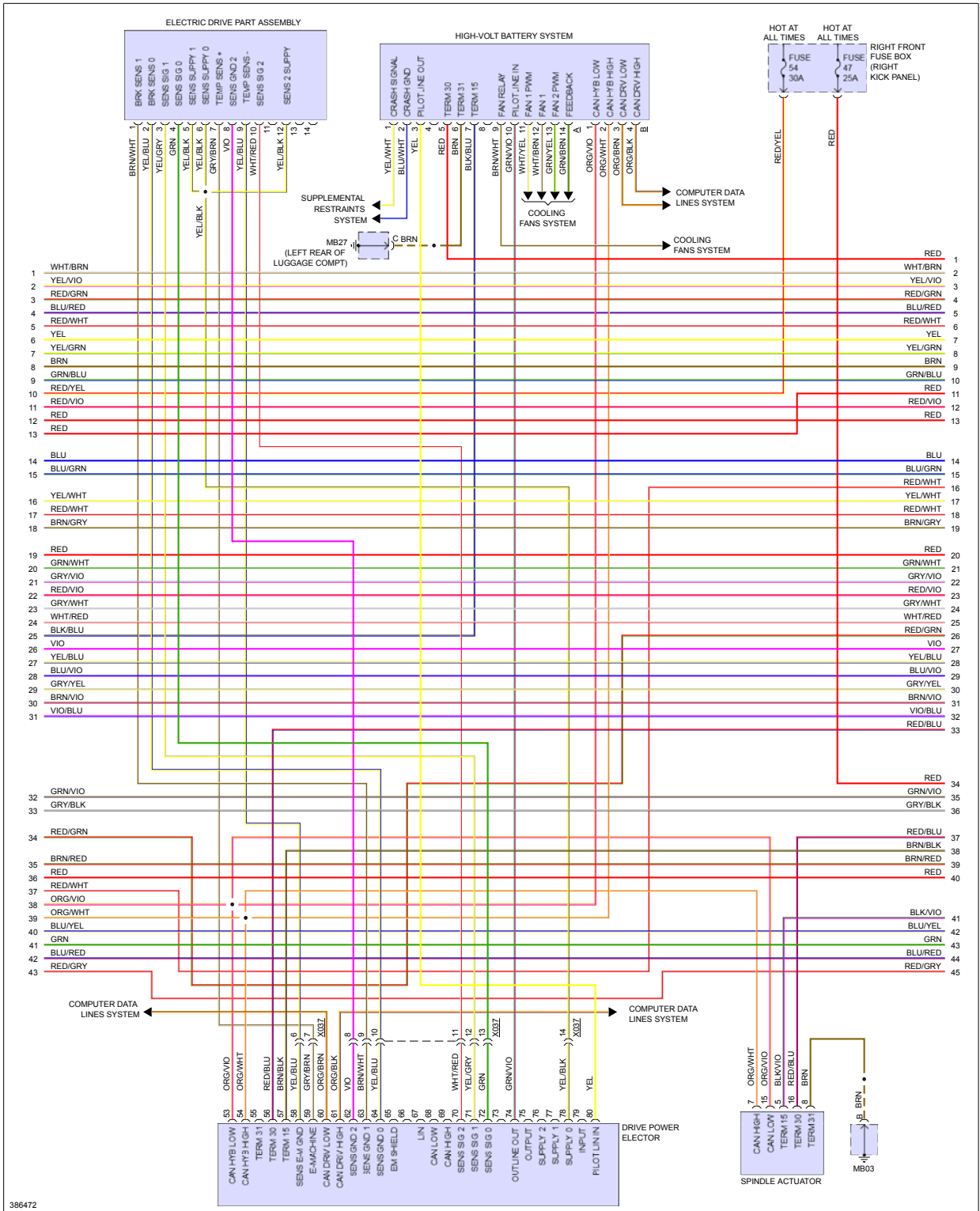
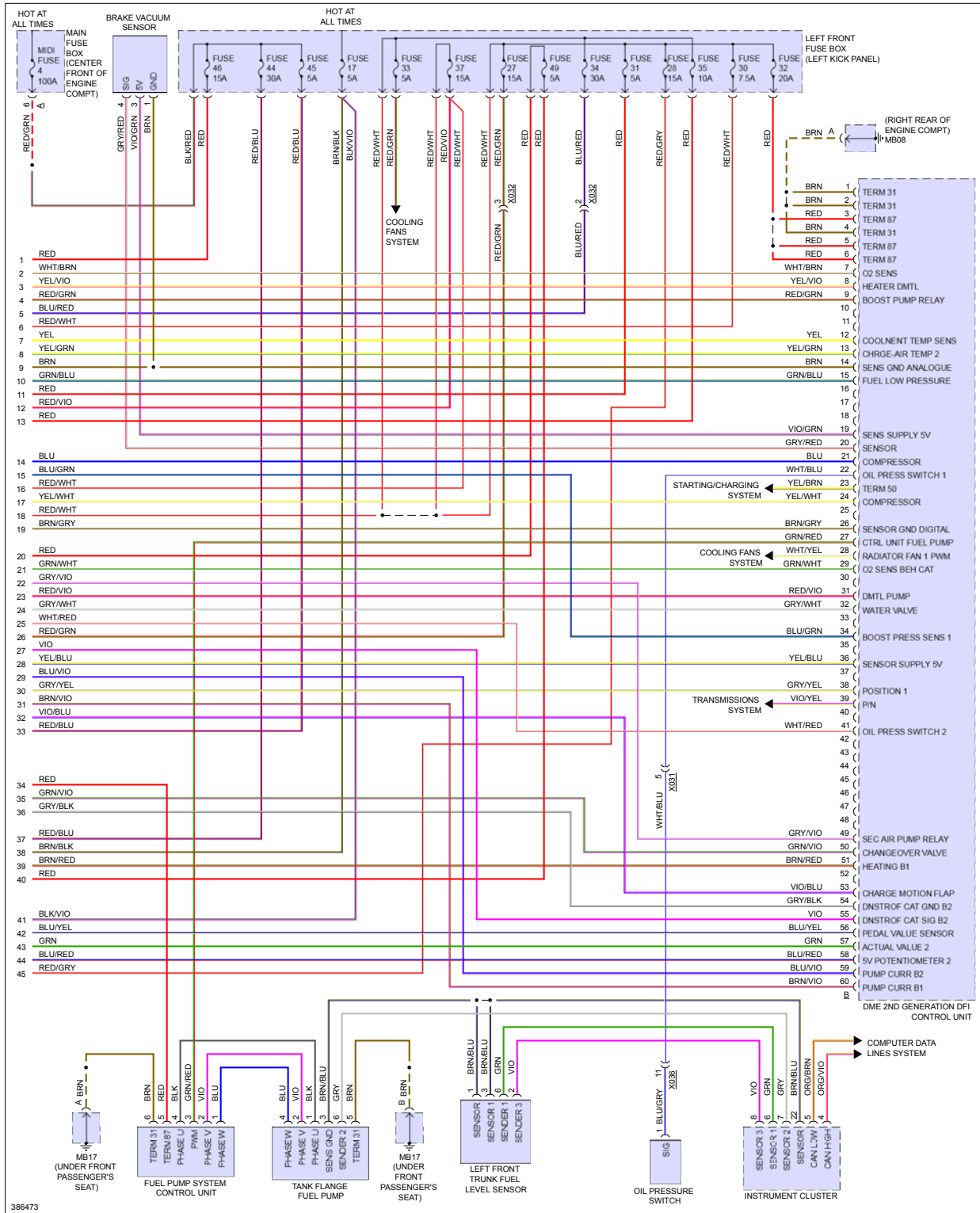

Fig 7: 3.0L Hybrid, Engine Performance Circuit (7 of 7)



# ENGINE PERFORMANCE > 3.6L

Fig 1: 3.6L, Engine Performance Circuit (1 of 5)

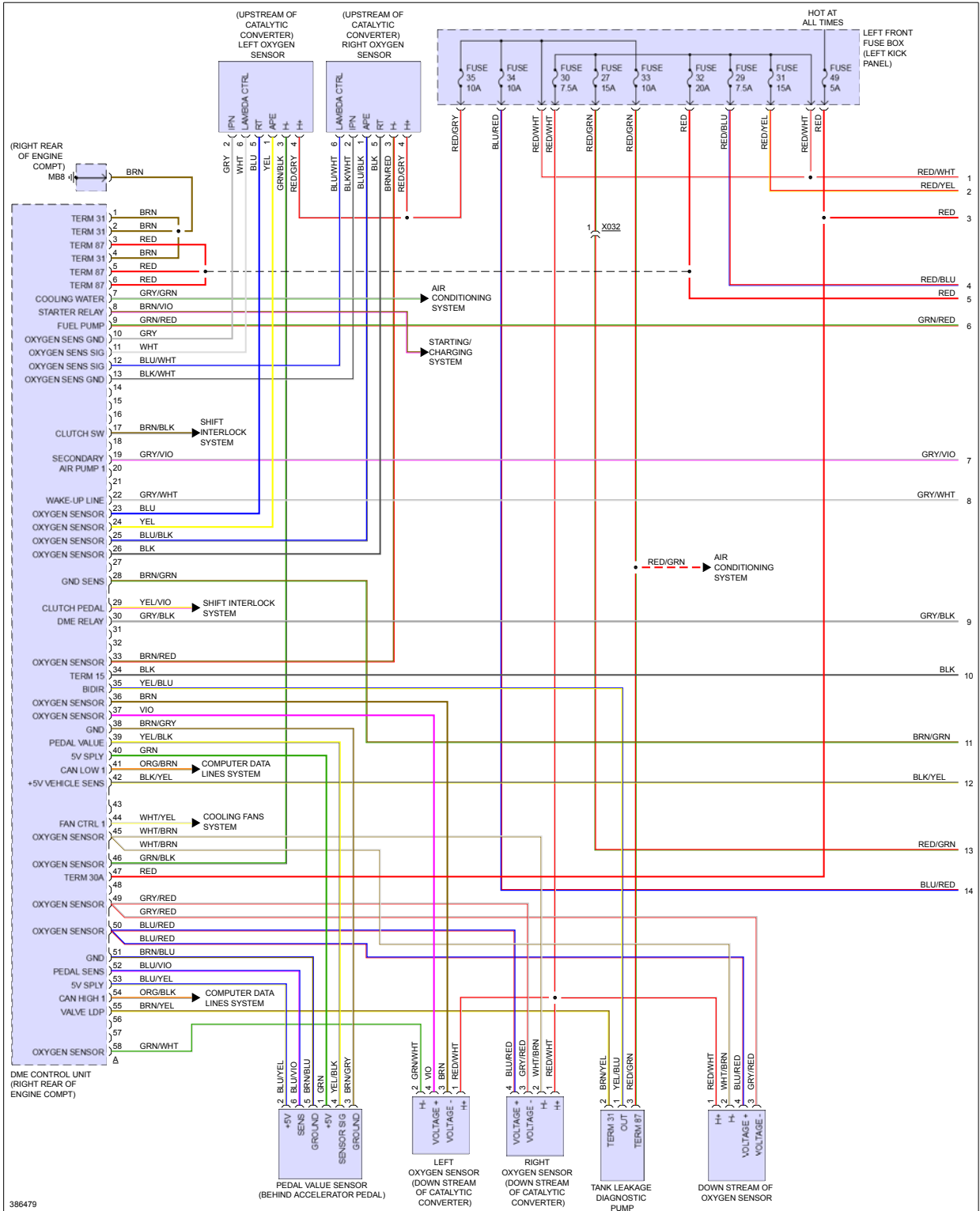

Fig 2: 3.6L, Engine Performance Circuit (2 of 5)

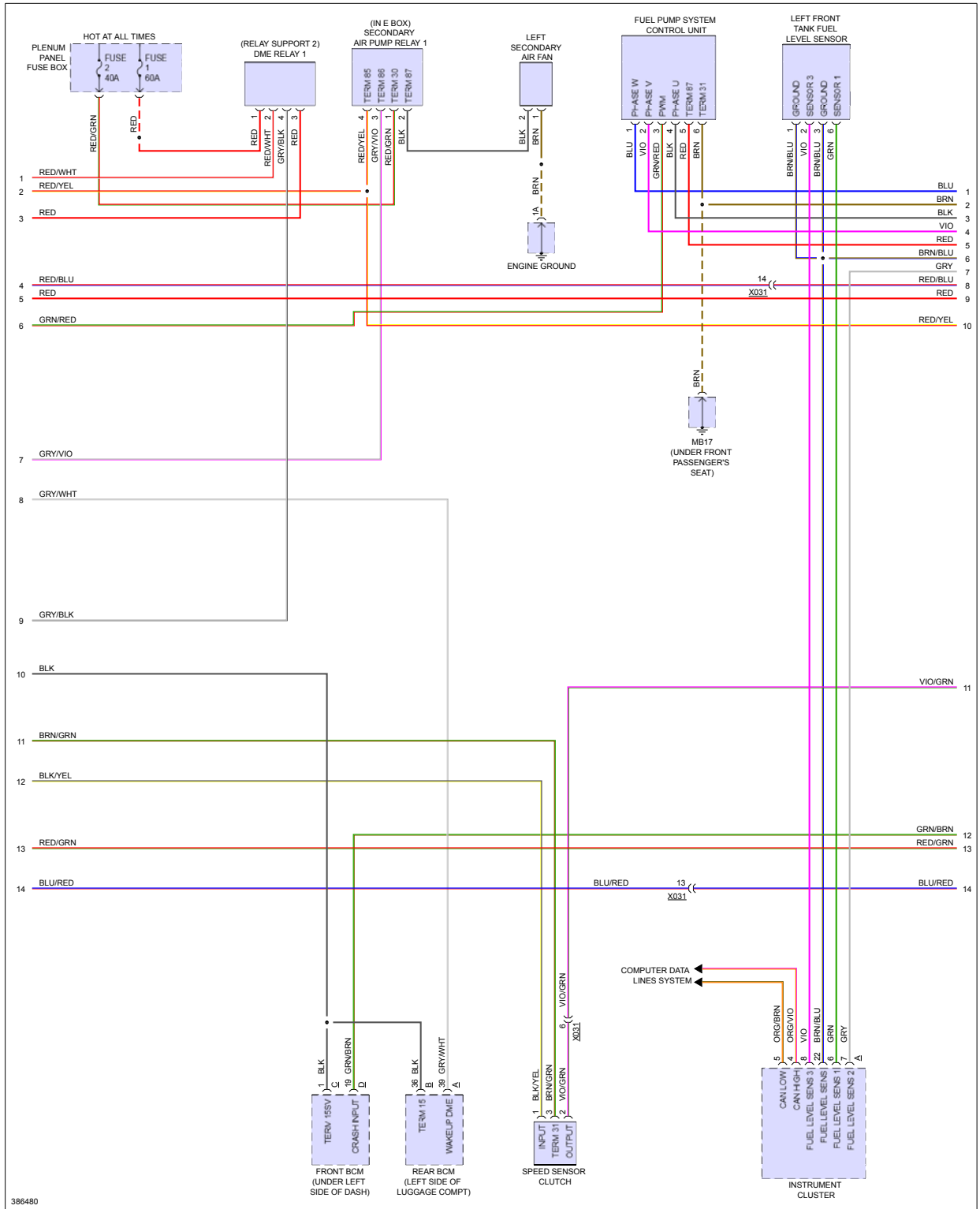

Fig 3: 3.6L, Engine Performance Circuit (3 of 5)

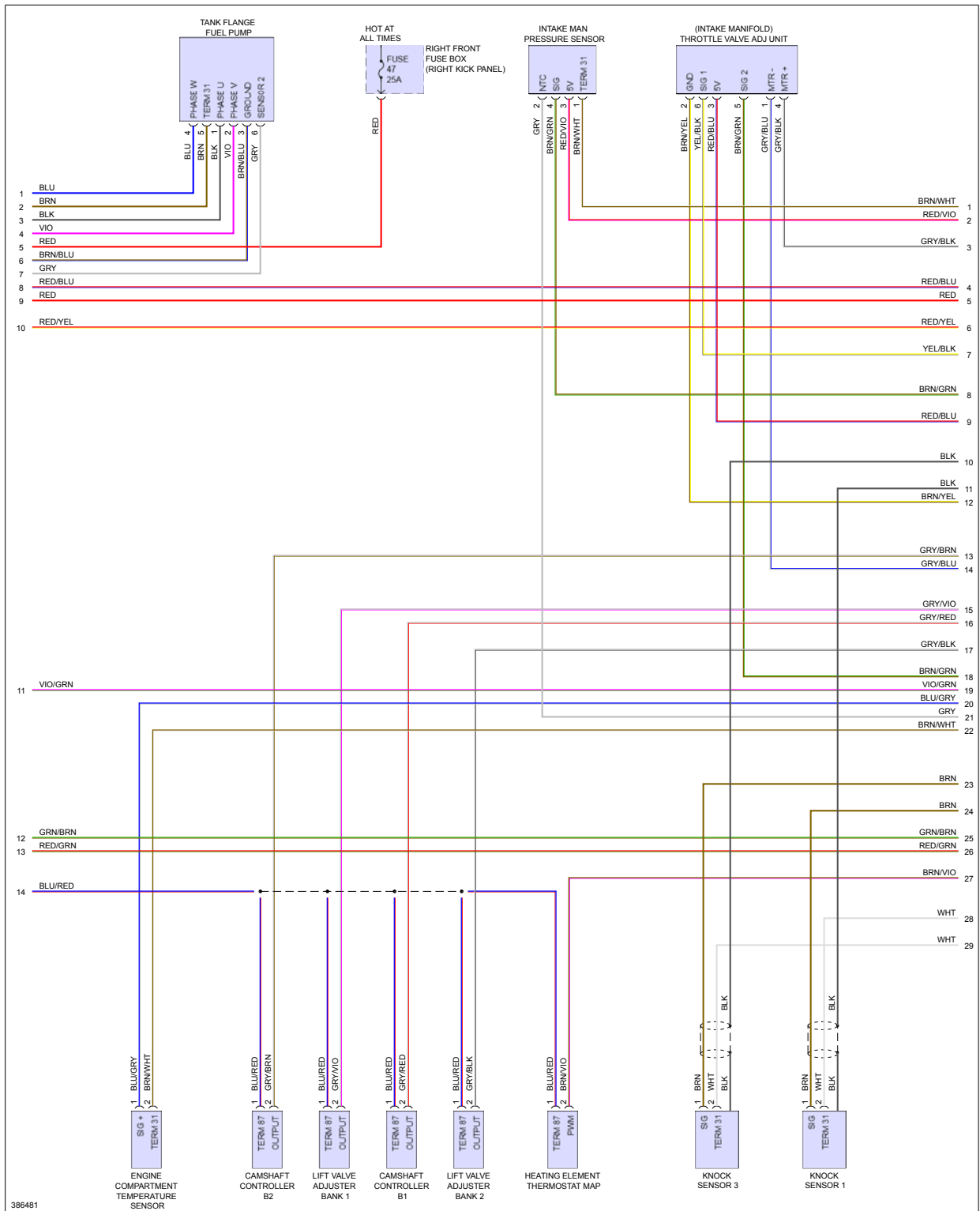

Fig 4: 3.6L, Engine Performance Circuit (4 of 5)

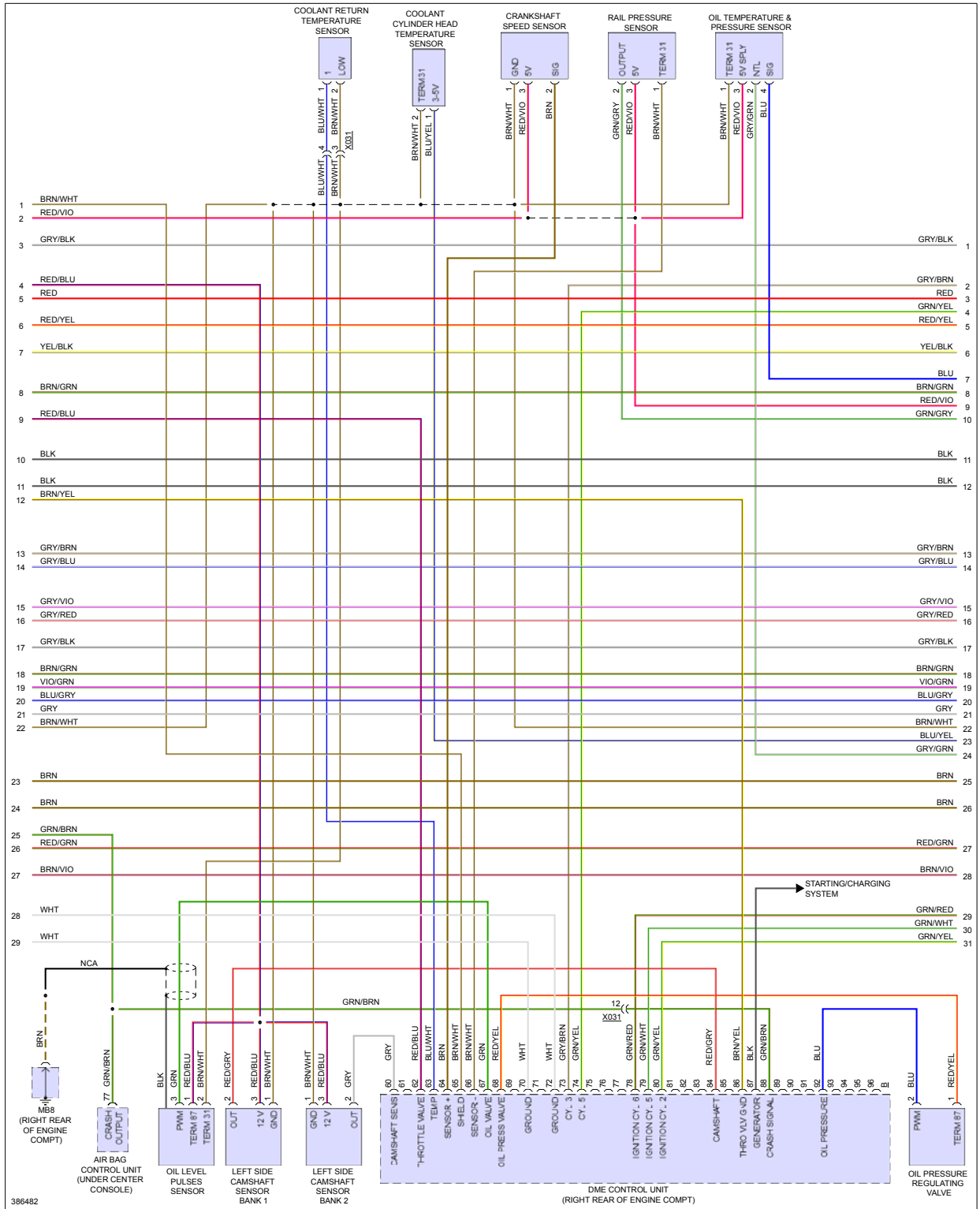
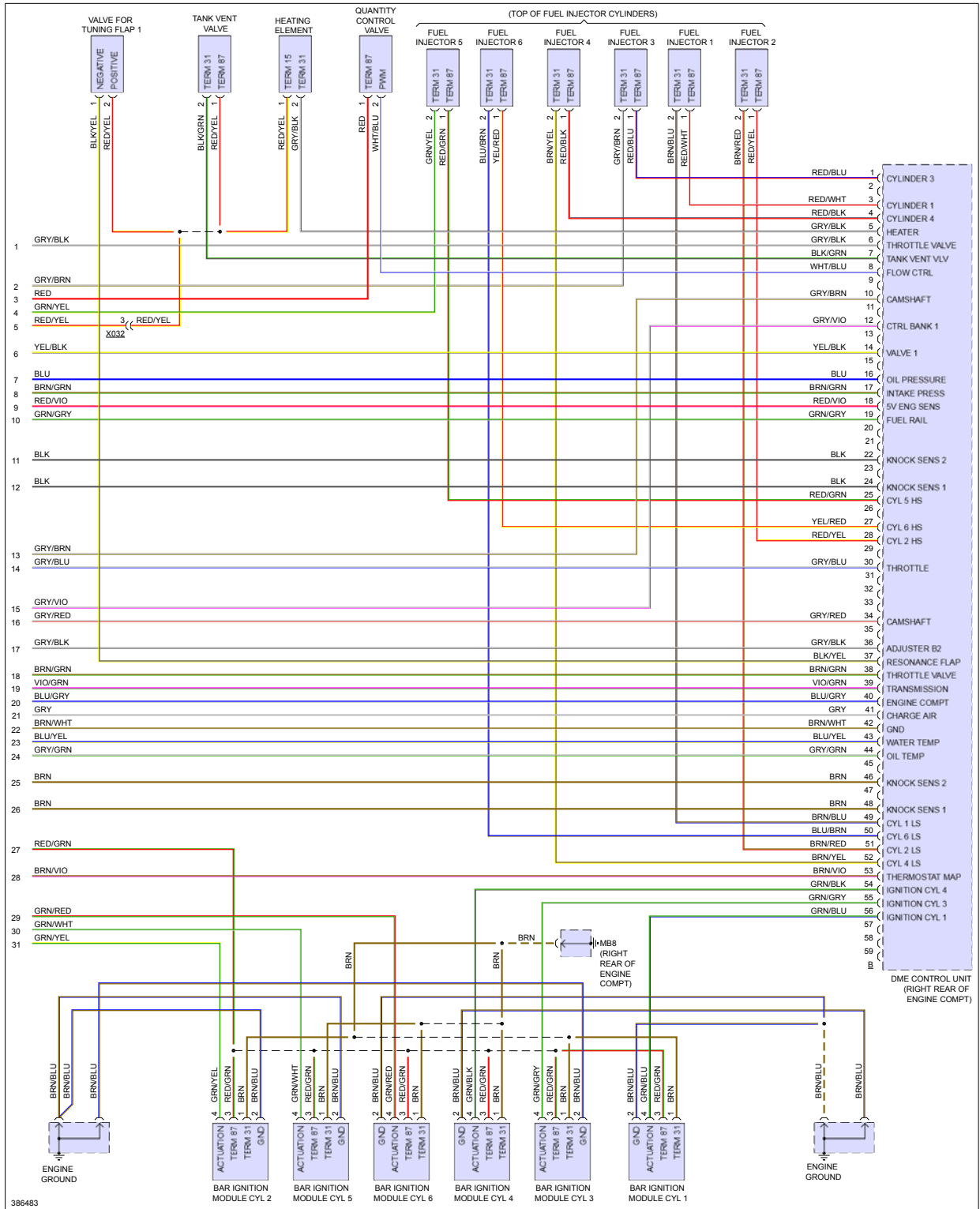

Fig 5: 3.6L, Engine Performance Circuit (5 of 5)





# ENGINE PERFORMANCE > 4.8L

Fig 1: 4.8L, Engine Performance Circuit (1 of 5)

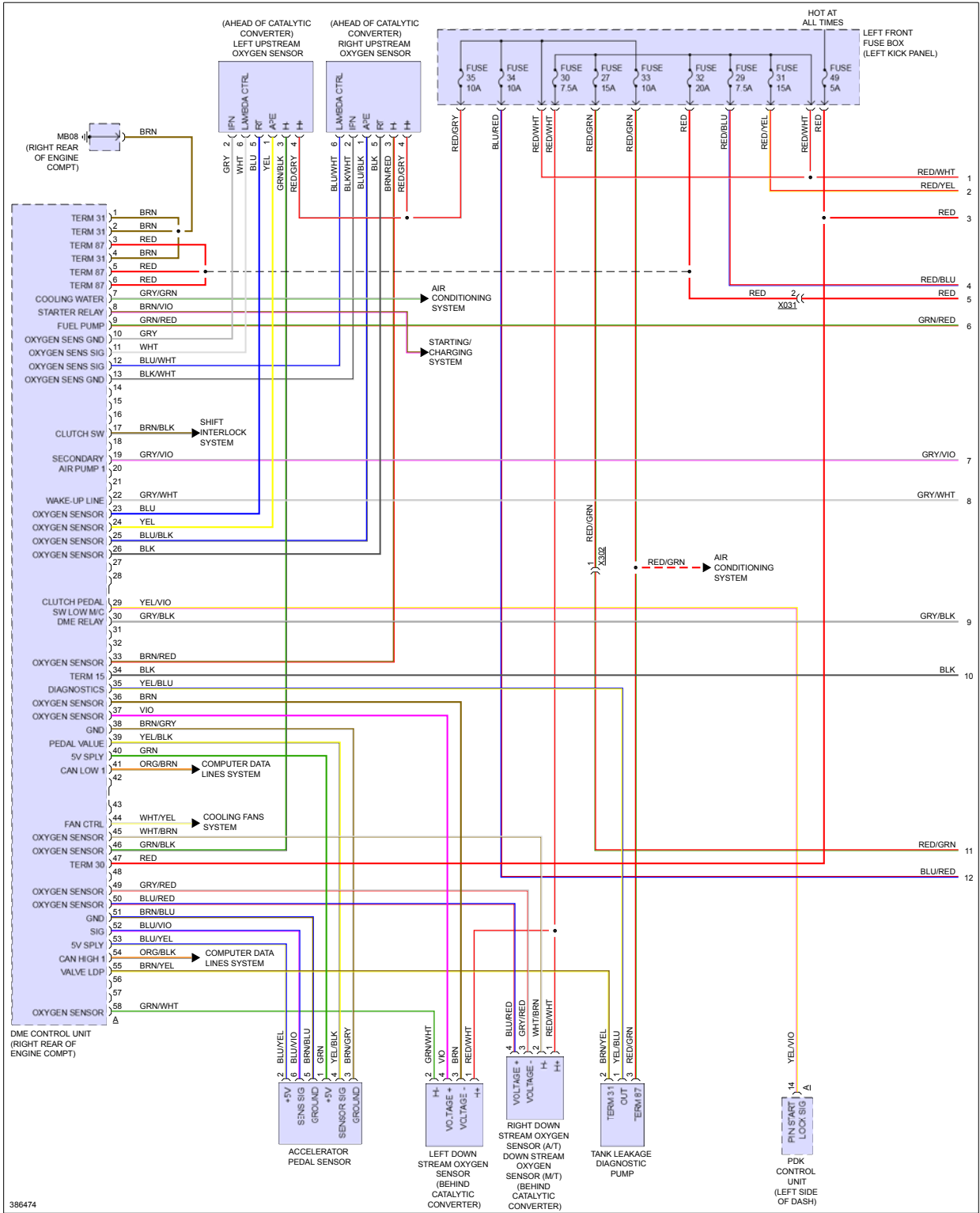

Fig 2: 4.8L, Engine Performance Circuit (2 of 5)

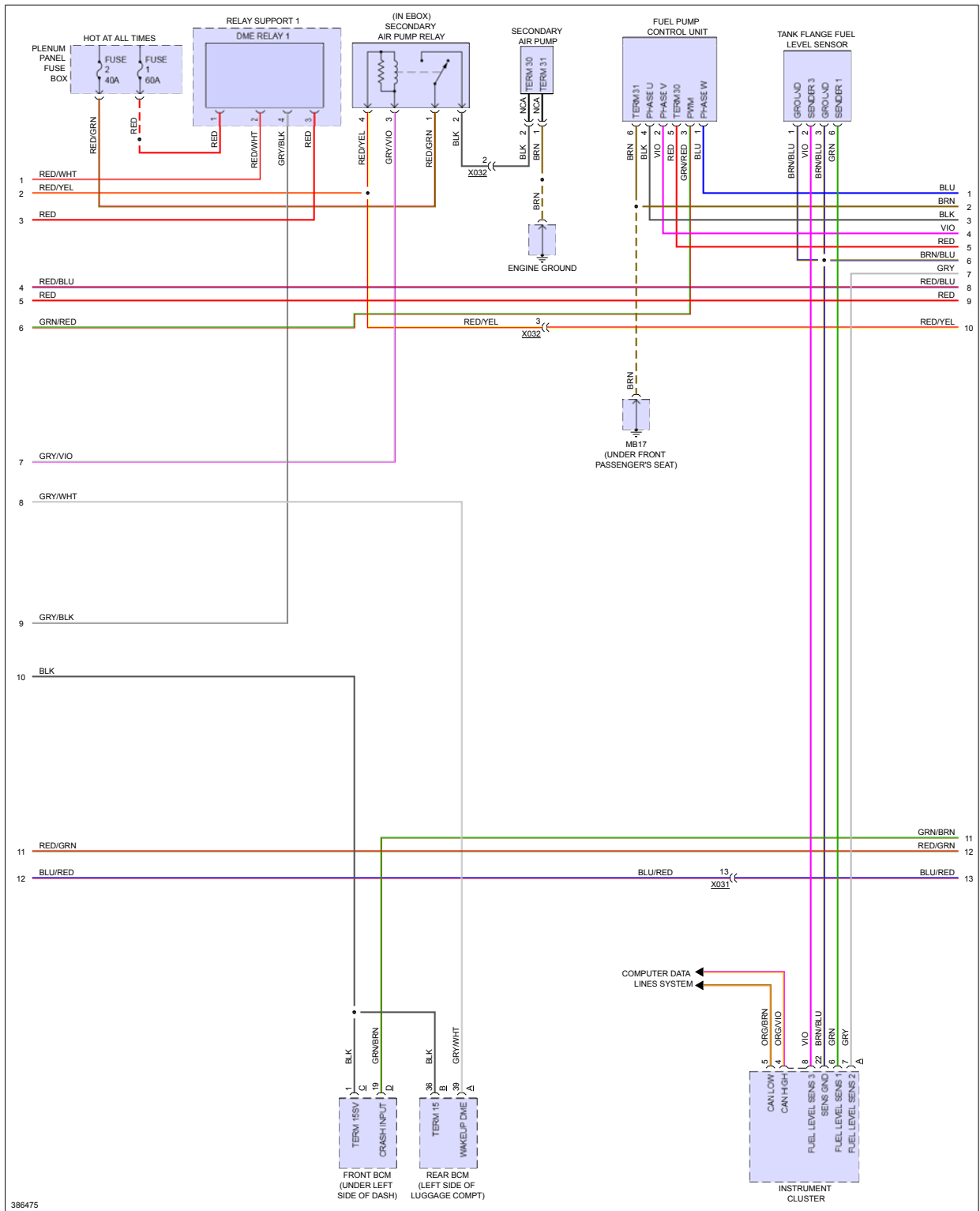

Fig 3: 4.8L, Engine Performance Circuit (3 of 5)

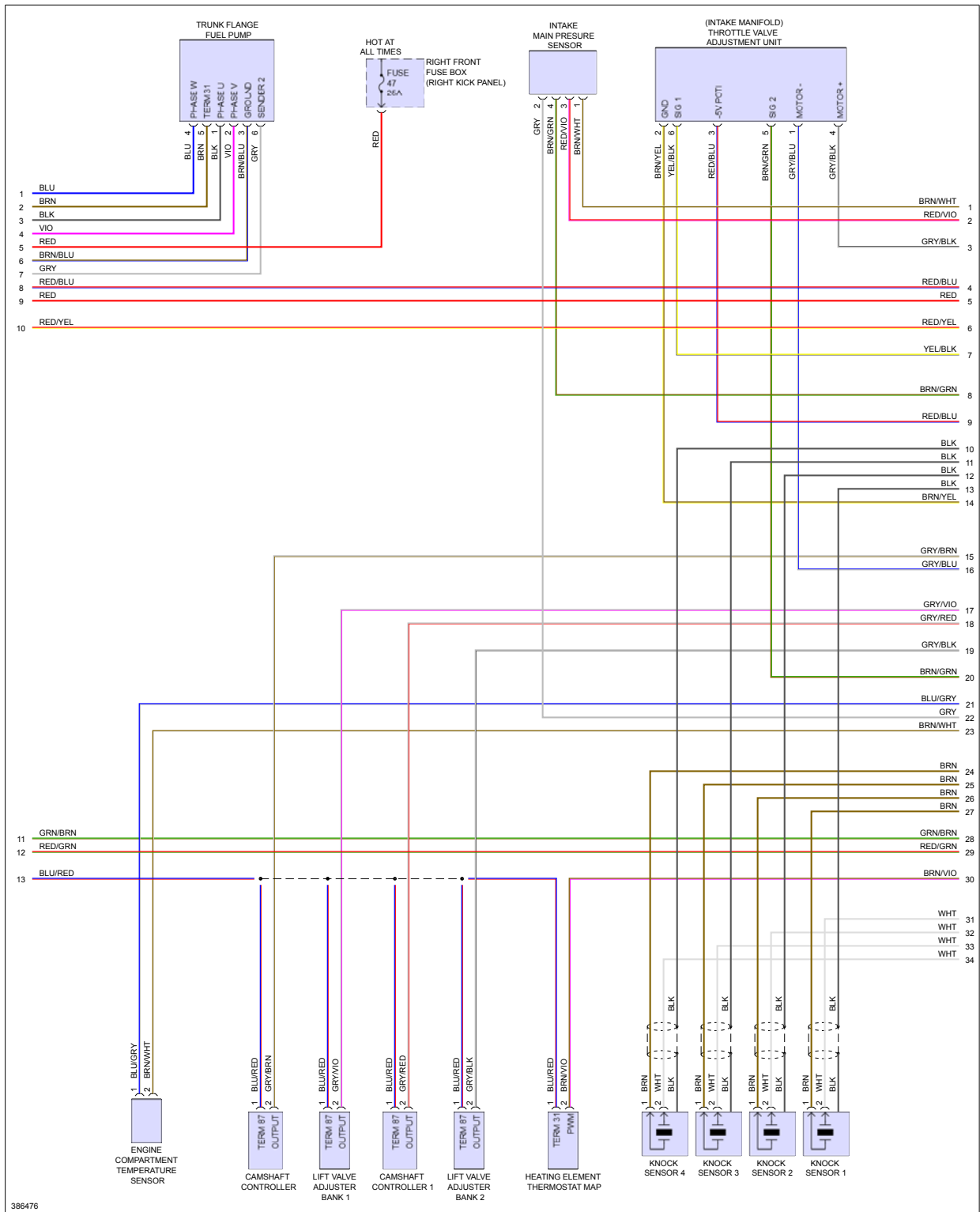

Fig 4: 4.8L, Engine Performance Circuit (4 of 5)

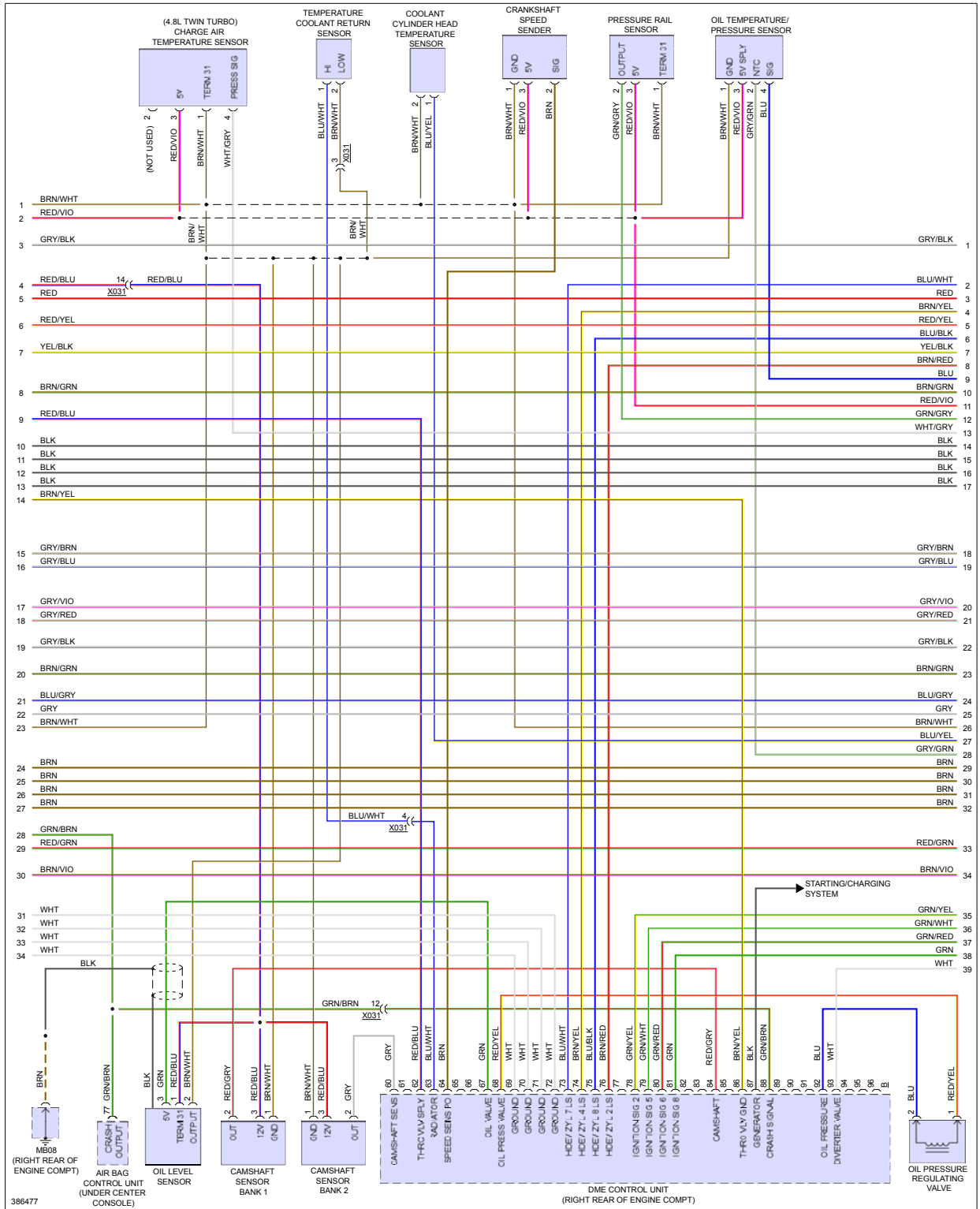
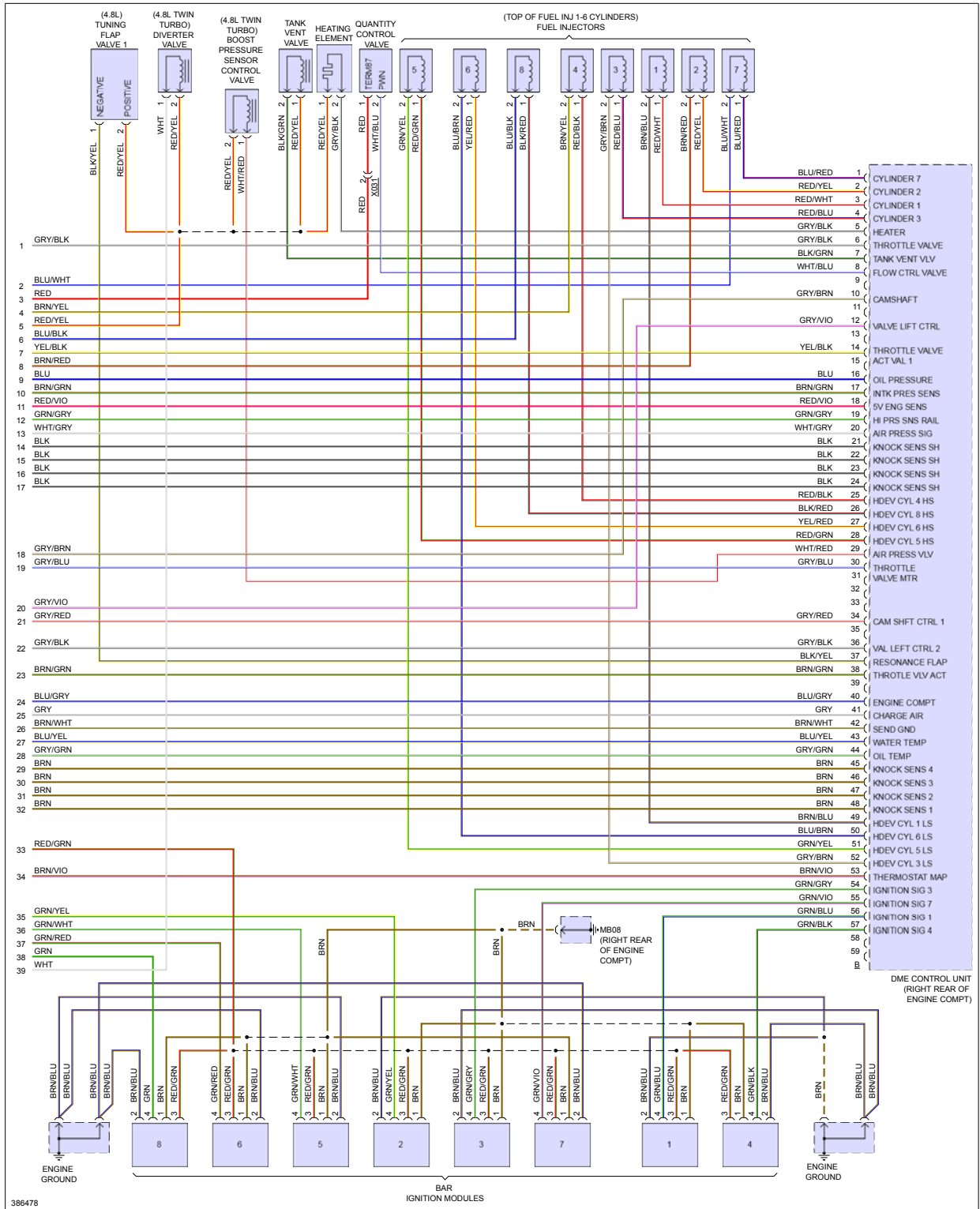

Fig 5: 4.8L, Engine Performance Circuit (5 of 5)



# ENGINE PERFORMANCE > 4.8L TWIN TURBO

Fig 1: 4.8L Twin Turbo, Engine Performance Circuit (1 of 5)

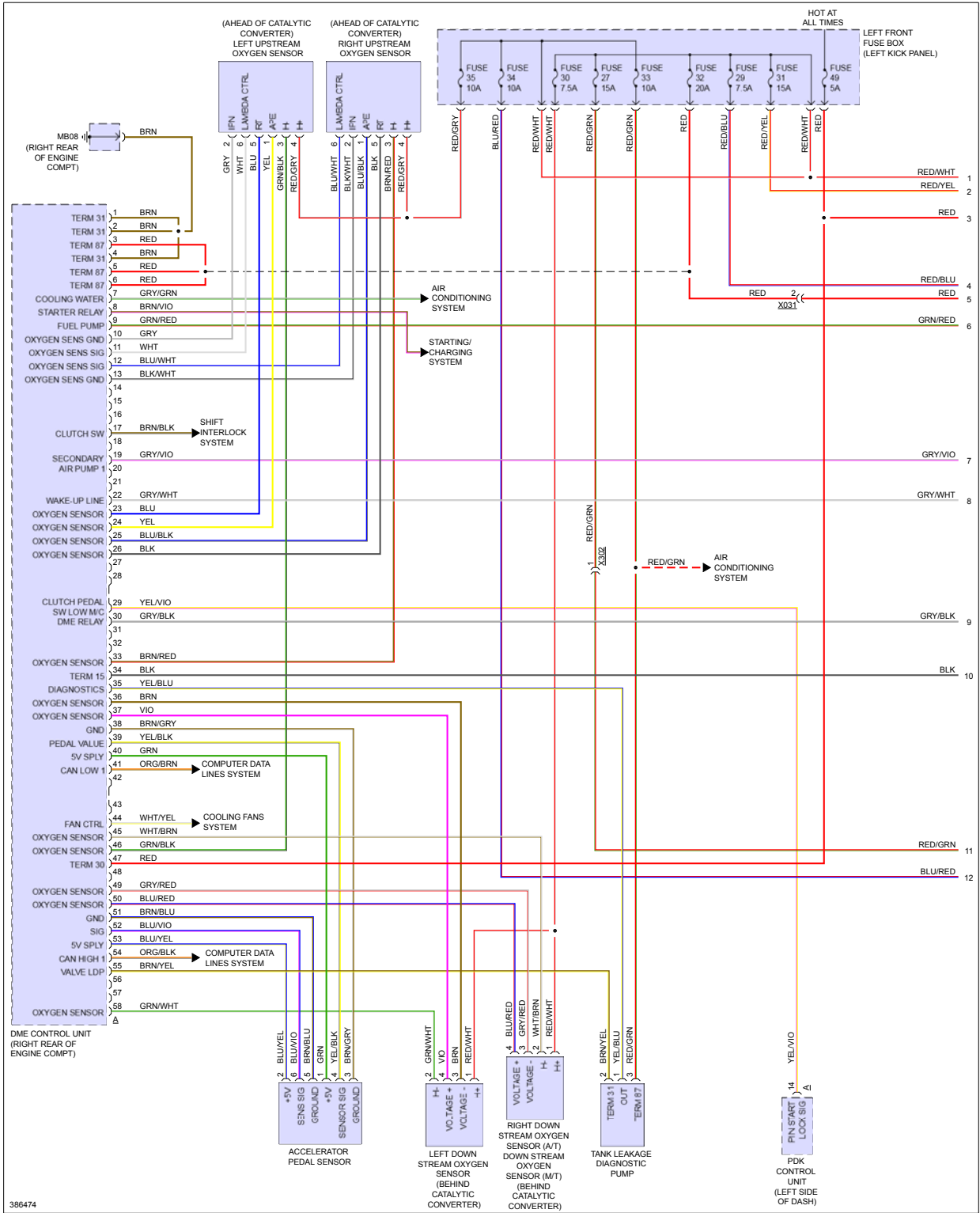

Fig 2: 4.8L Twin Turbo, Engine Performance Circuit (2 of 5)

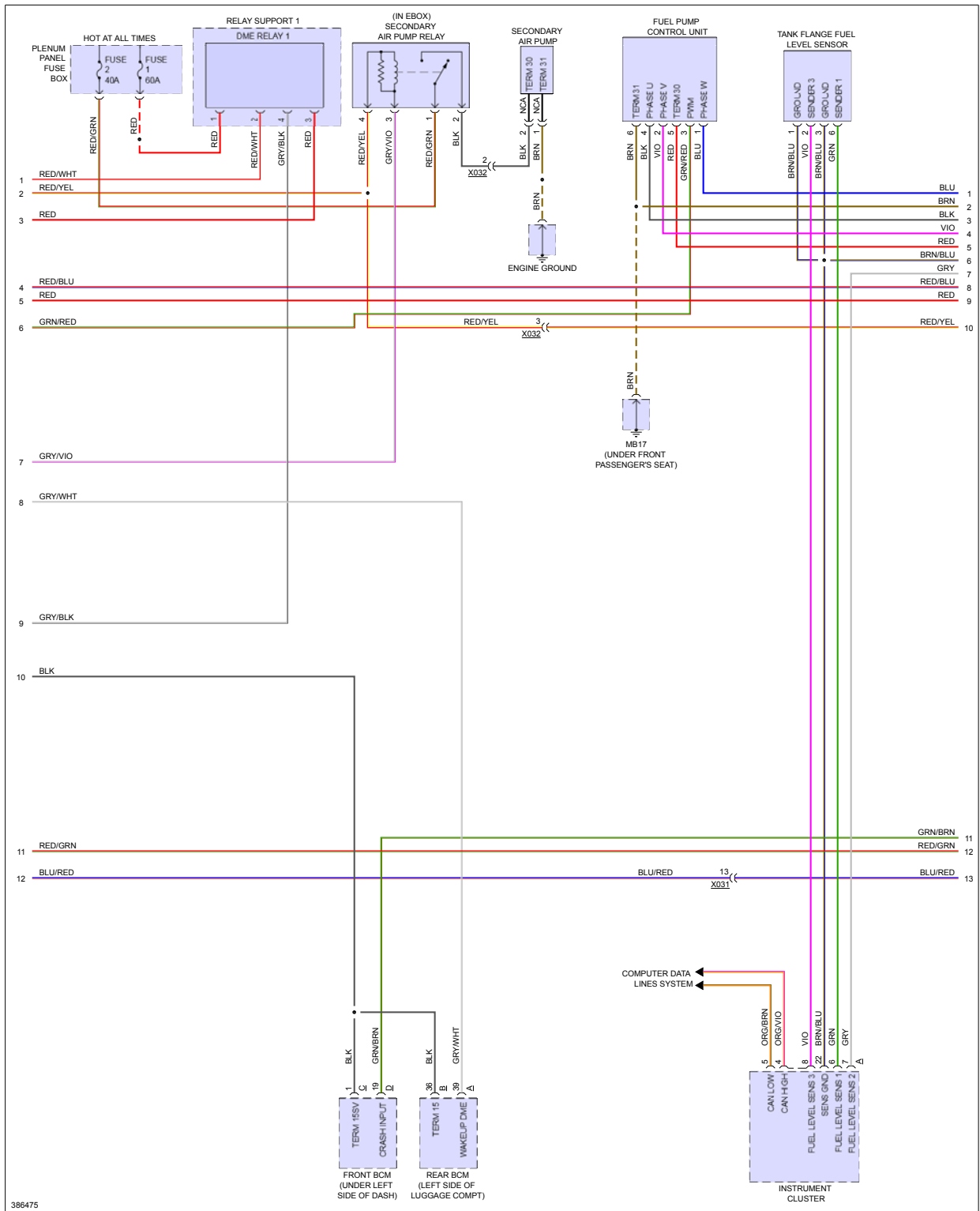

Fig 3: 4.8L Twin Turbo, Engine Performance Circuit (3 of 5)

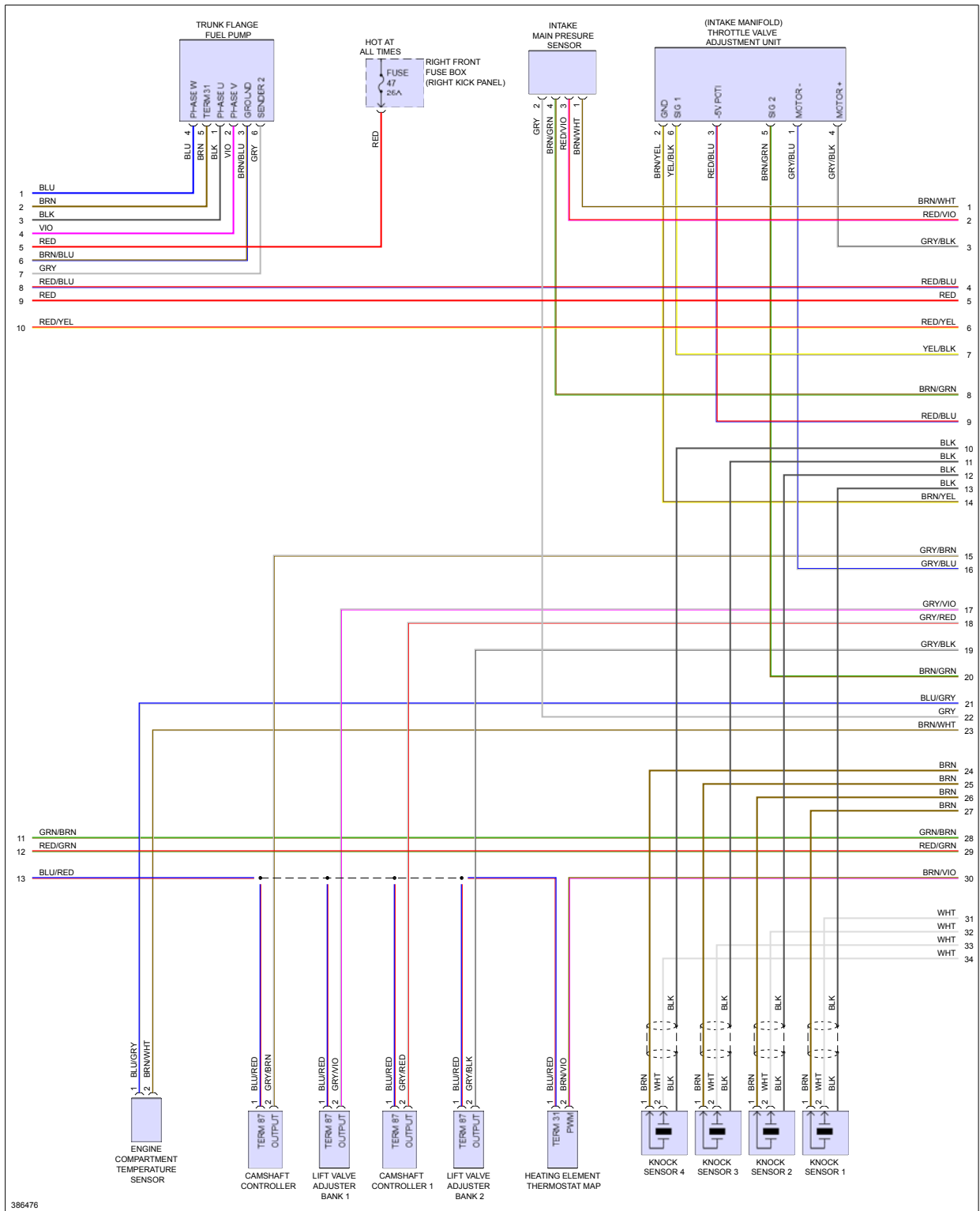
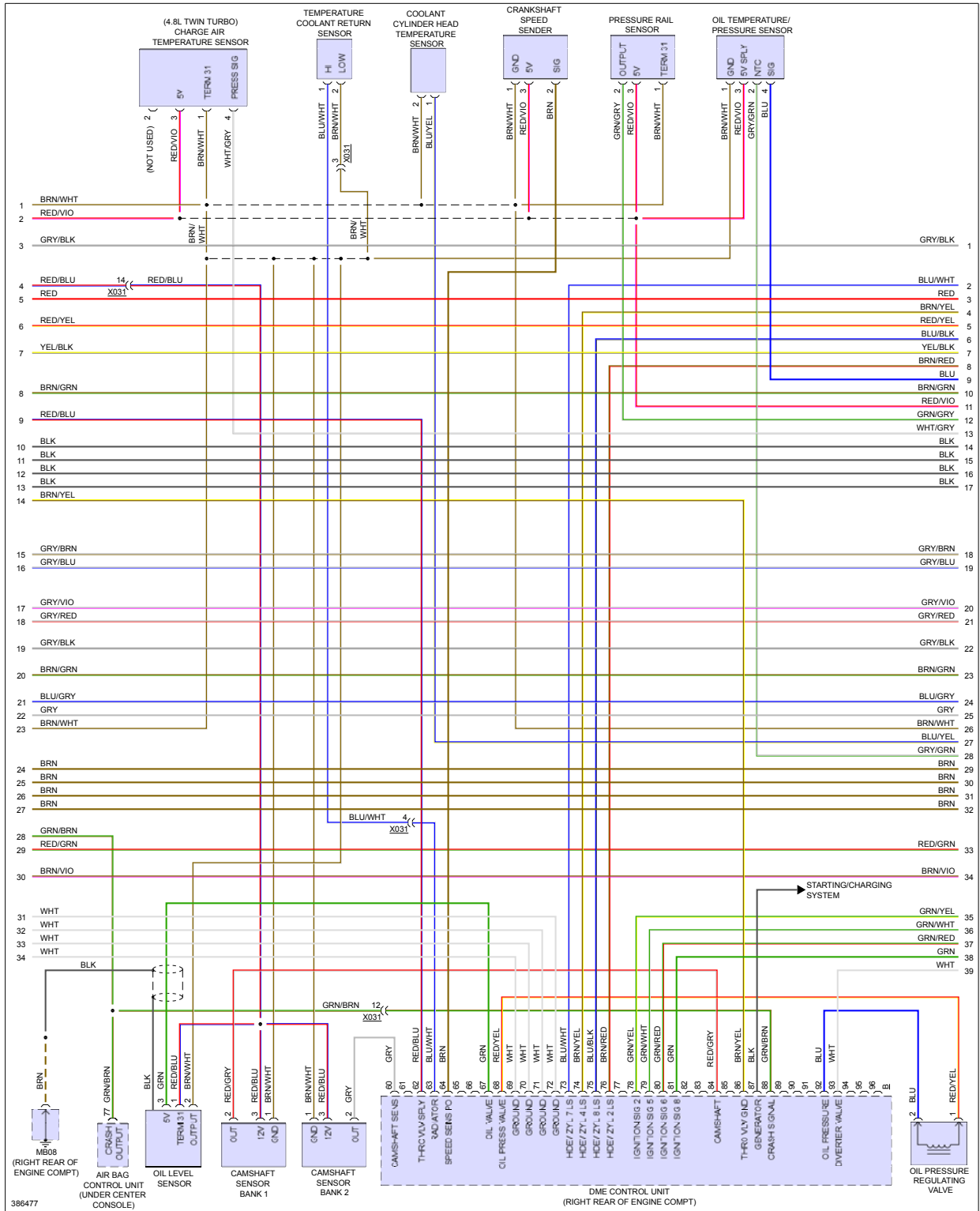

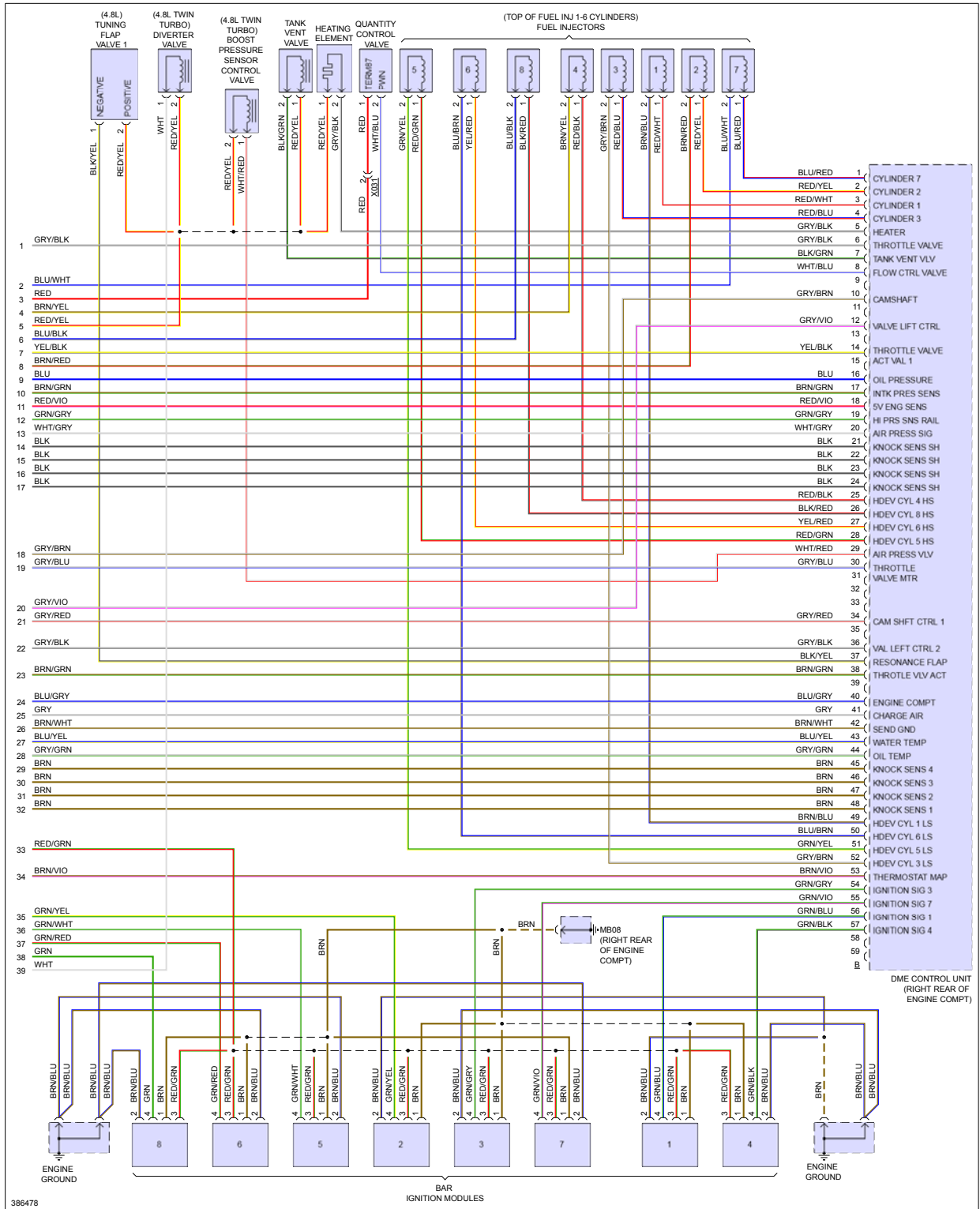

Fig 4: 4.8L Twin Turbo, Engine Performance Circuit (4 of 5)



386477

Fig 5: 4.8L Twin Turbo, Engine Performance Circuit (5 of 5)



386478

# EXTERIOR LIGHTS

Fig 1: Backup Lamps Circuit

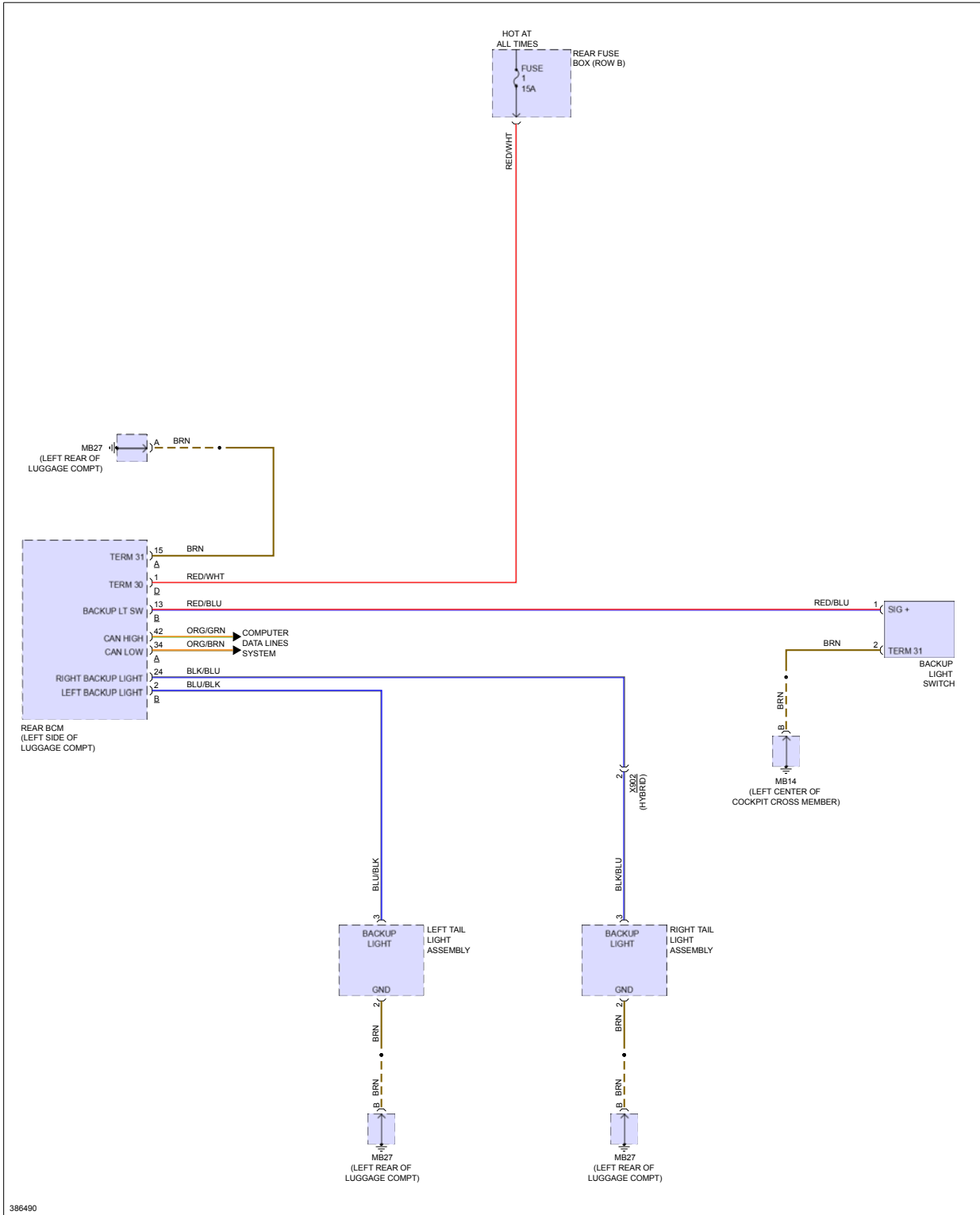

Fig 2: Exterior Lamps Circuit (1 of 2)

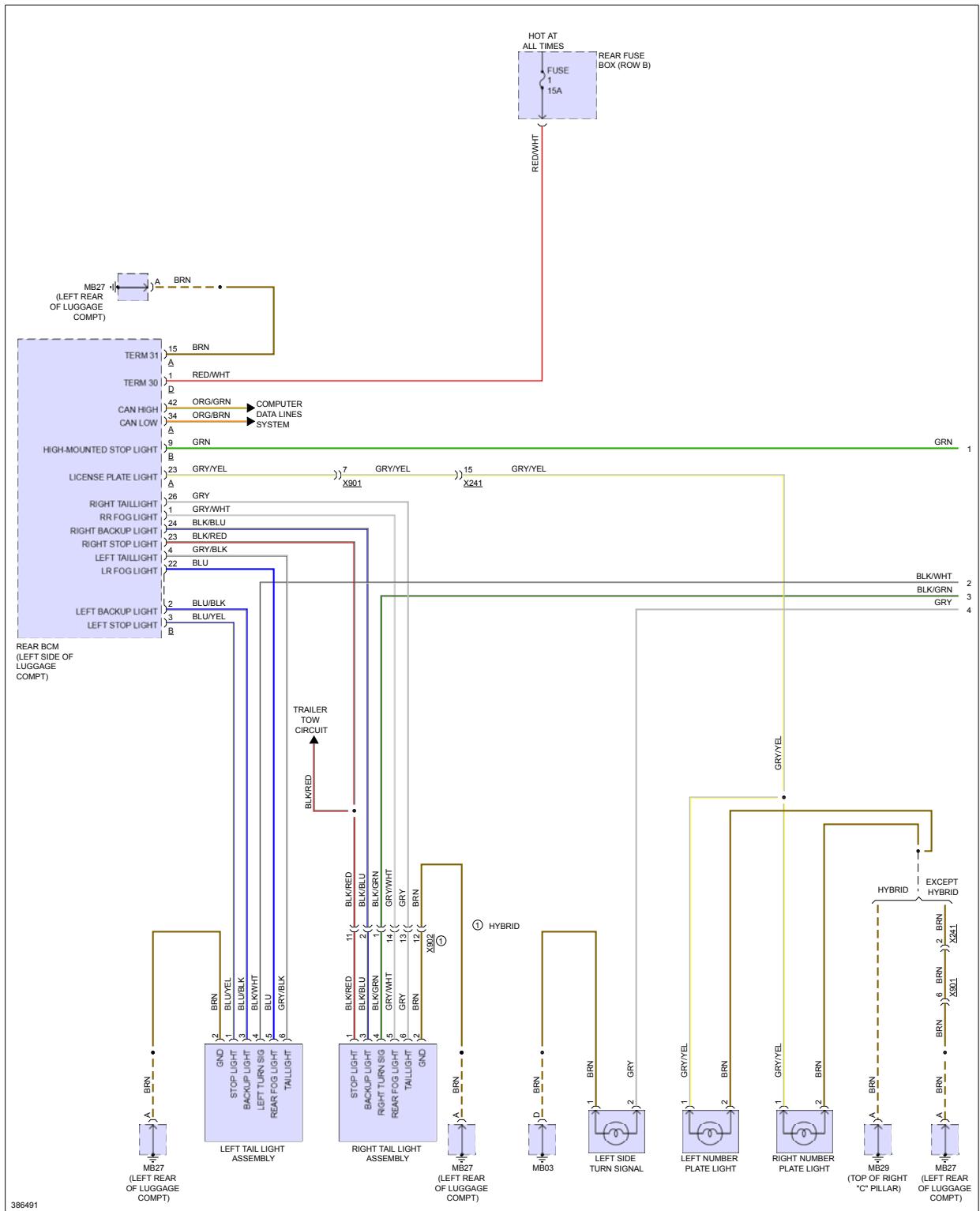

Fig 3: Exterior Lamps Circuit (2 of 2)

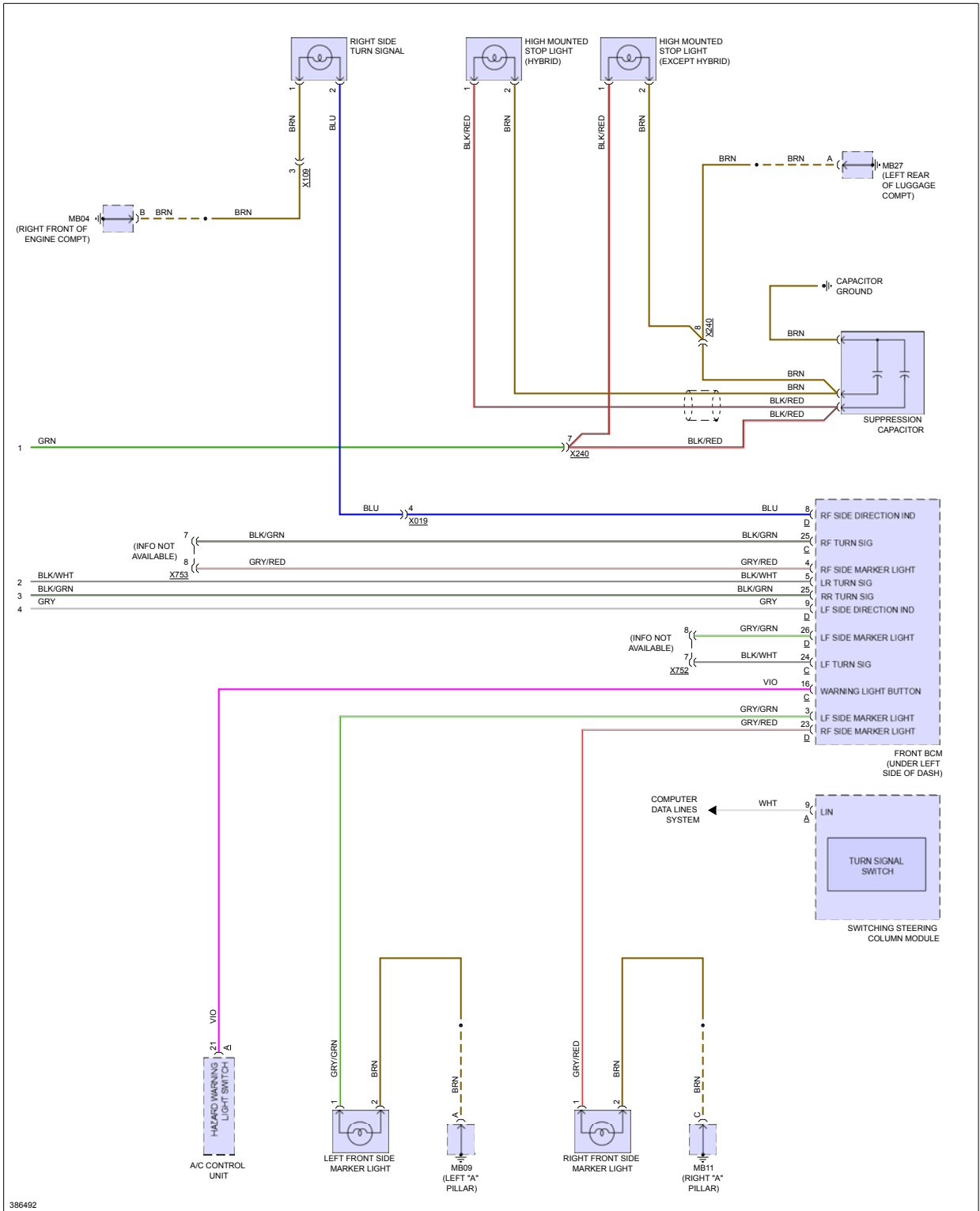
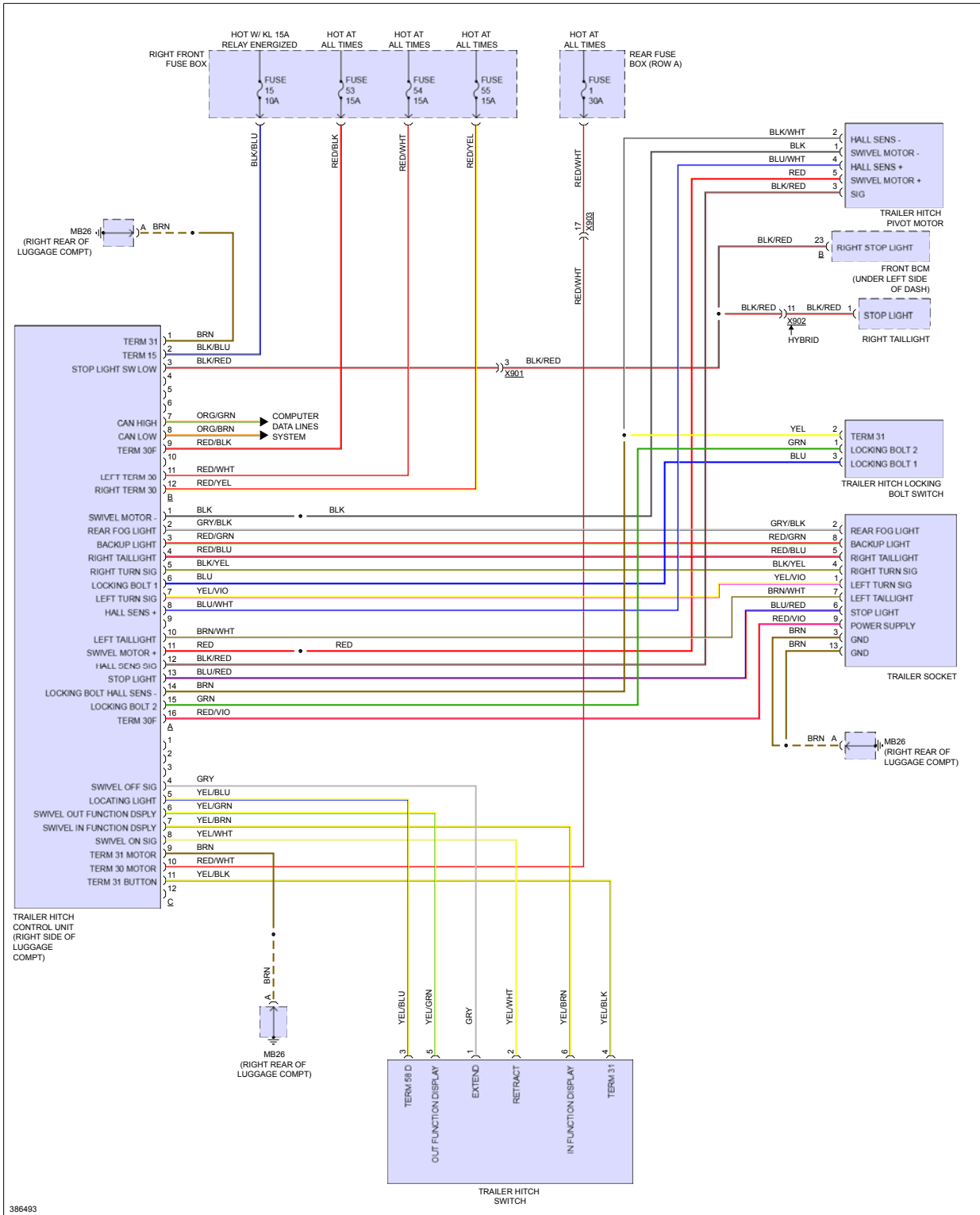

Fig 4: Trailer Tow Circuit



# GROUND DISTRIBUTION

Fig 1: Ground Distribution Circuit (1 of 6)

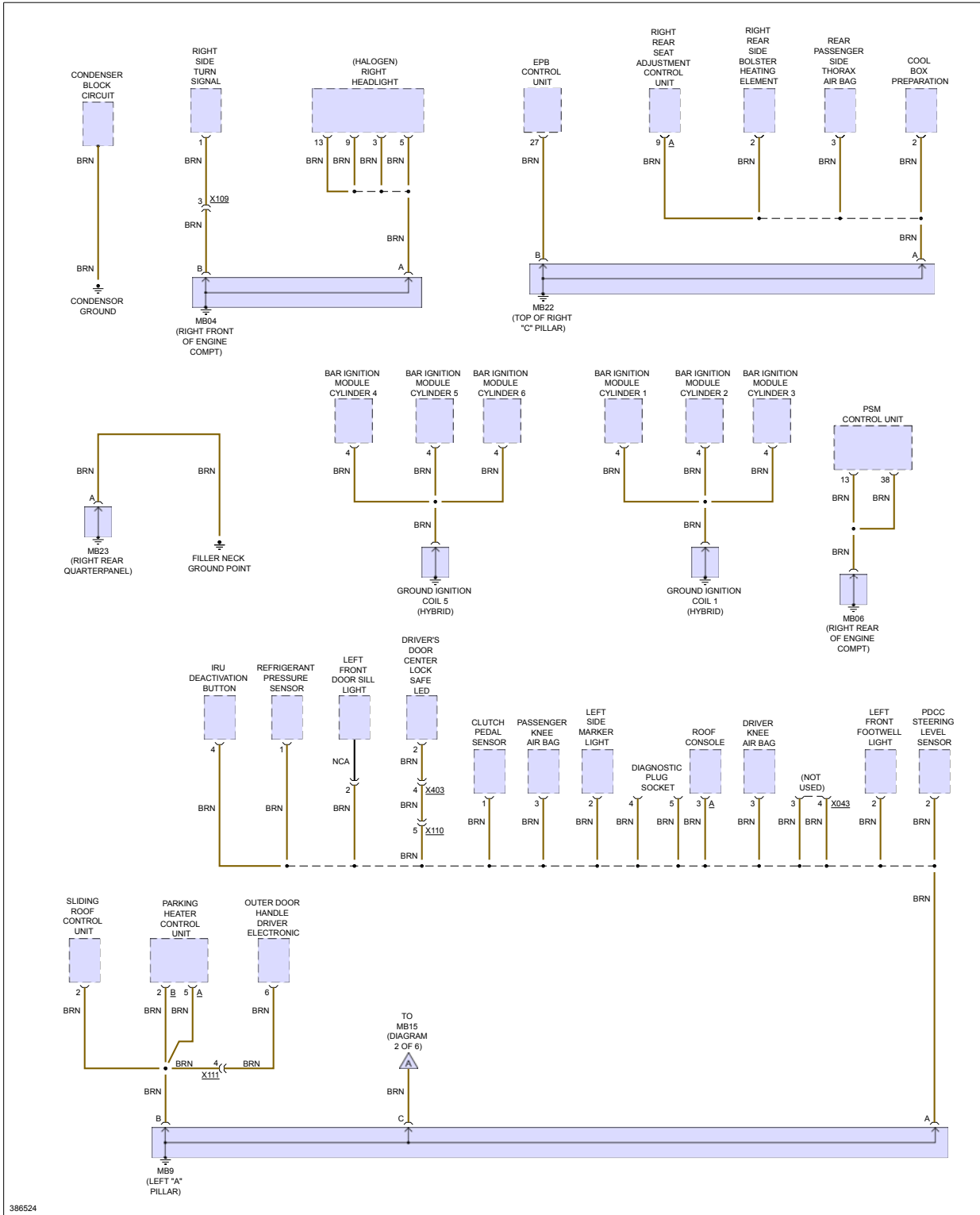

Fig 2: Ground Distribution Circuit (2 of 6)

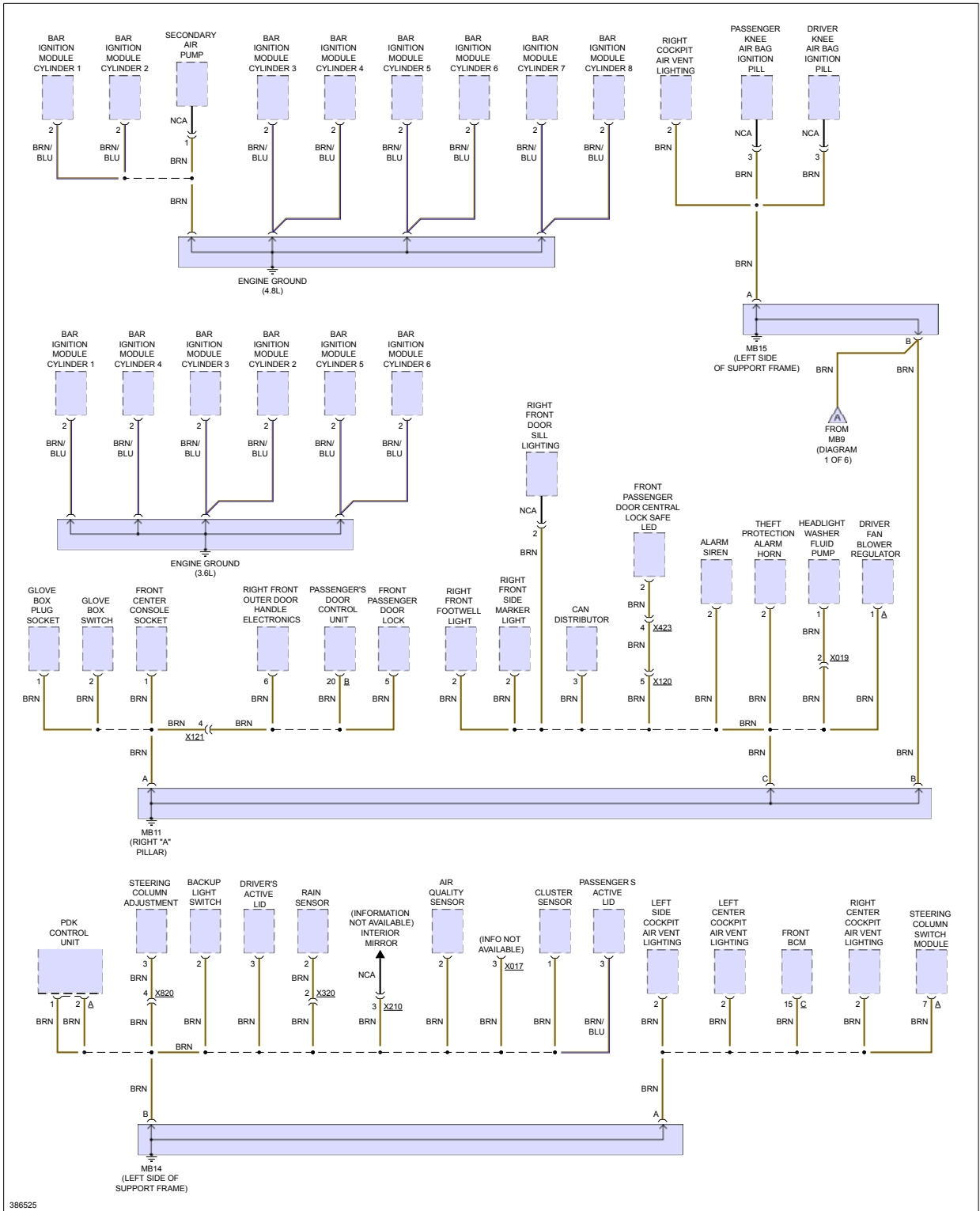



Fig 3: Ground Distribution Circuit (3 of 6)

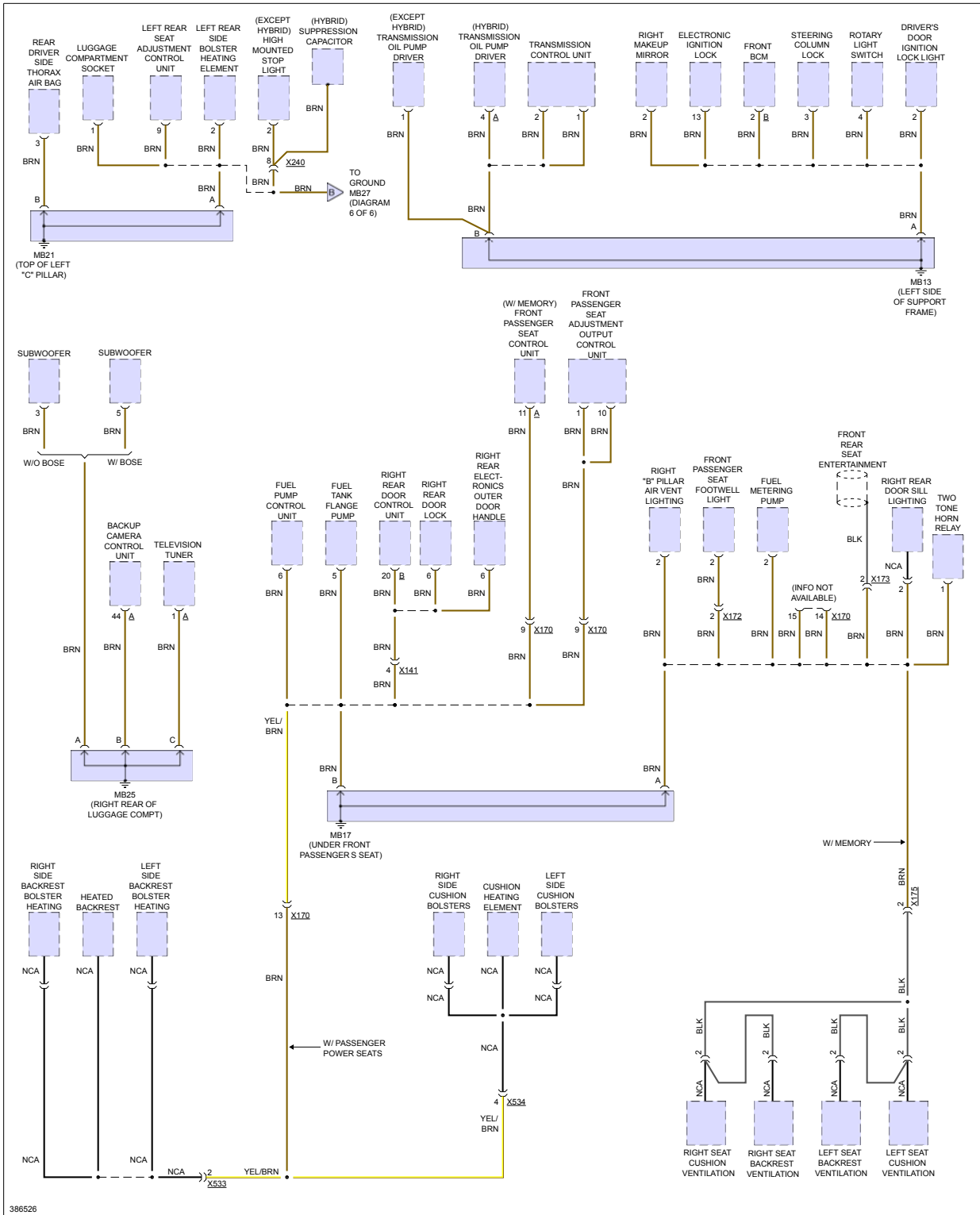

Fig 4: Ground Distribution Circuit (4 of 6)

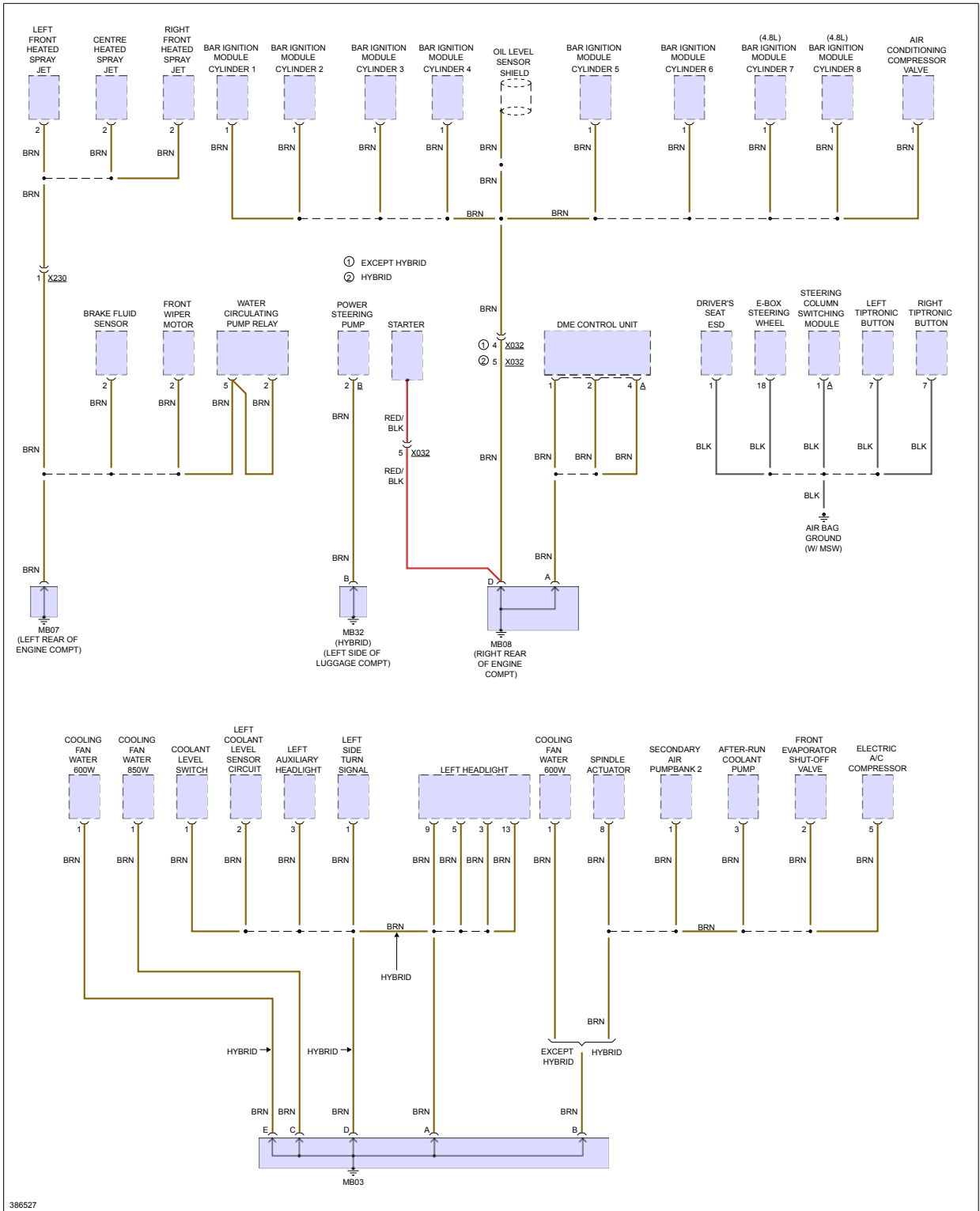

Fig 5: Ground Distribution Circuit (5 of 6)

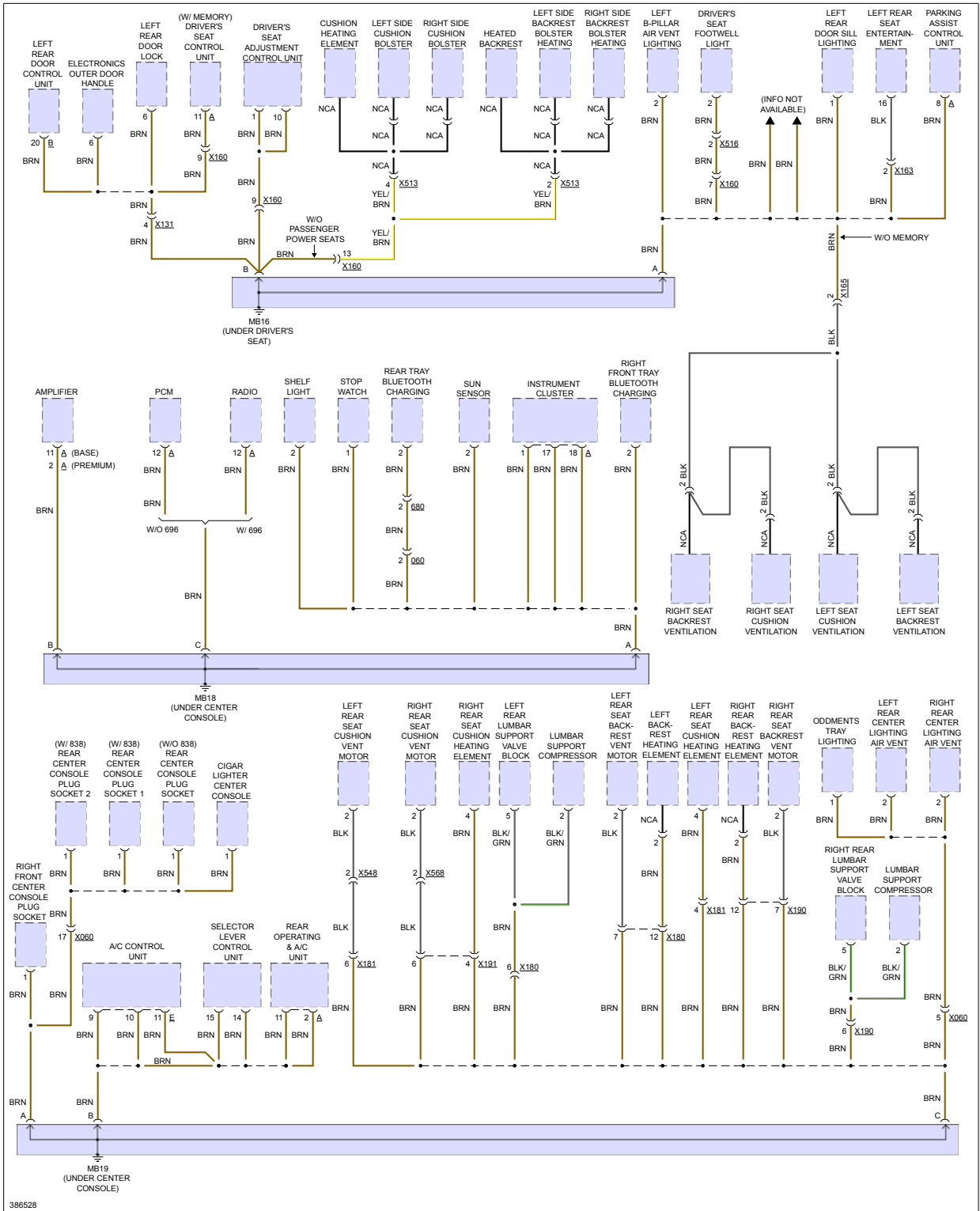
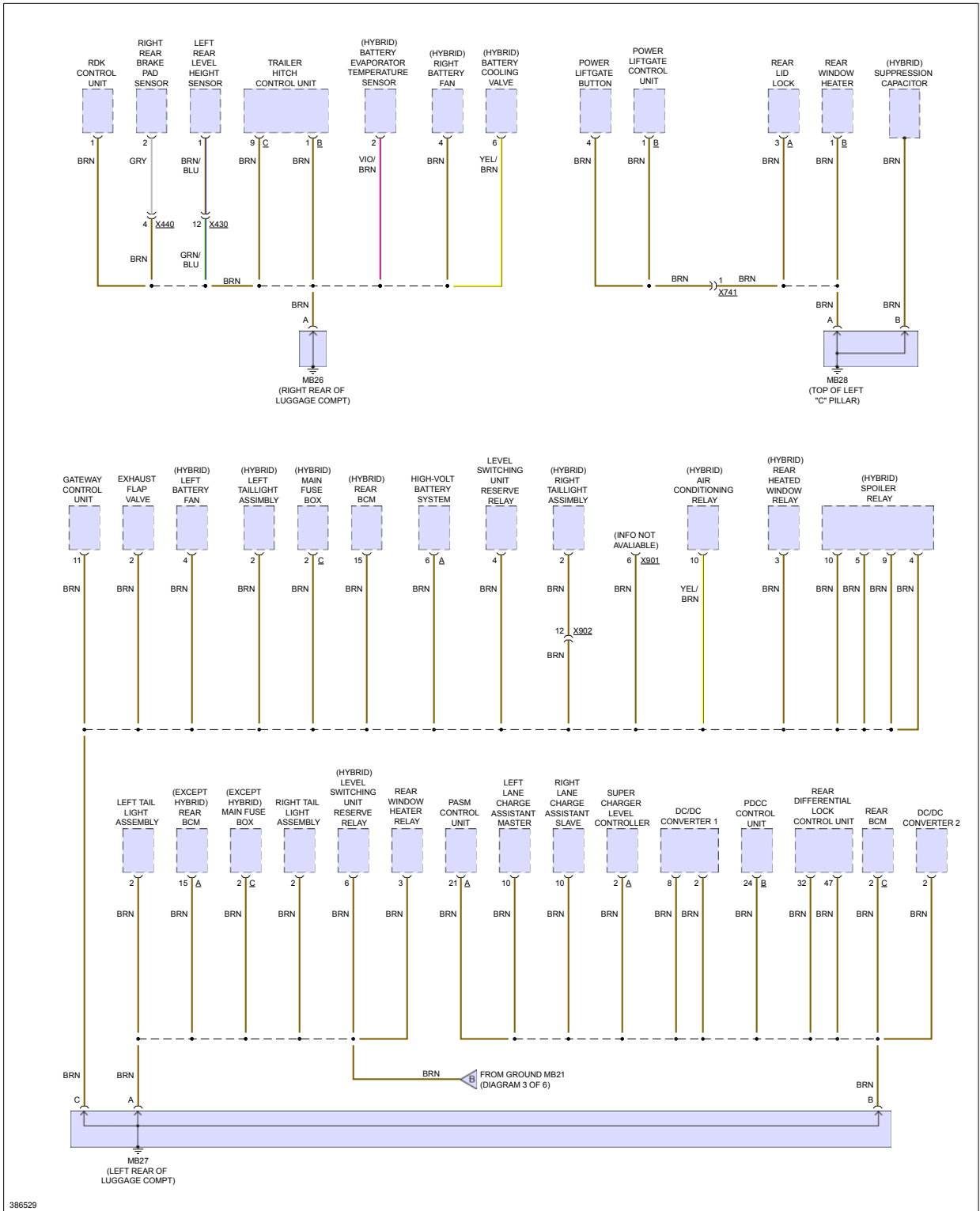

Fig 6: Ground Distribution Circuit (6 of 6)



# HEADLIGHTS

Fig 1: Headlights Circuit, W/ Cornering Headlights

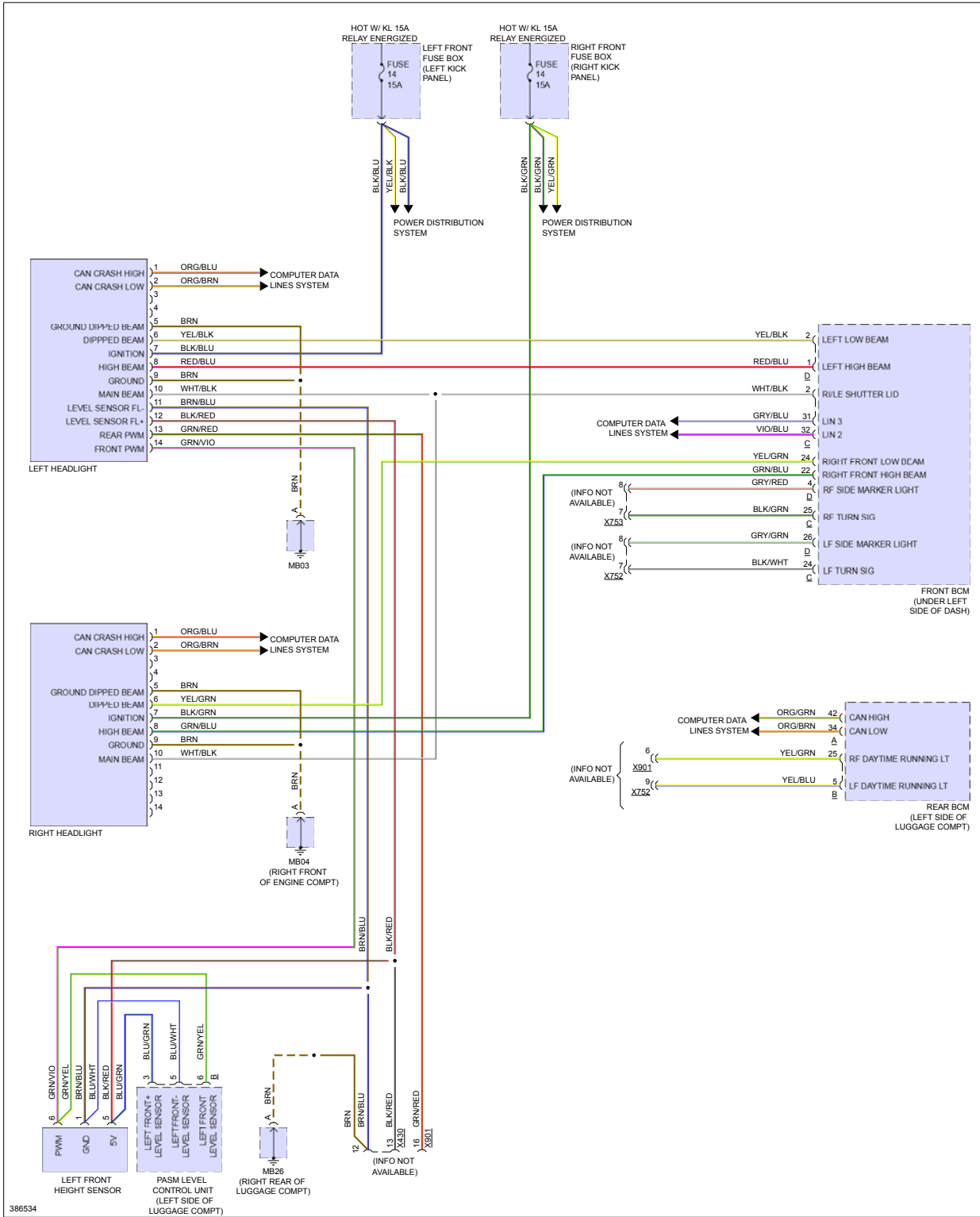
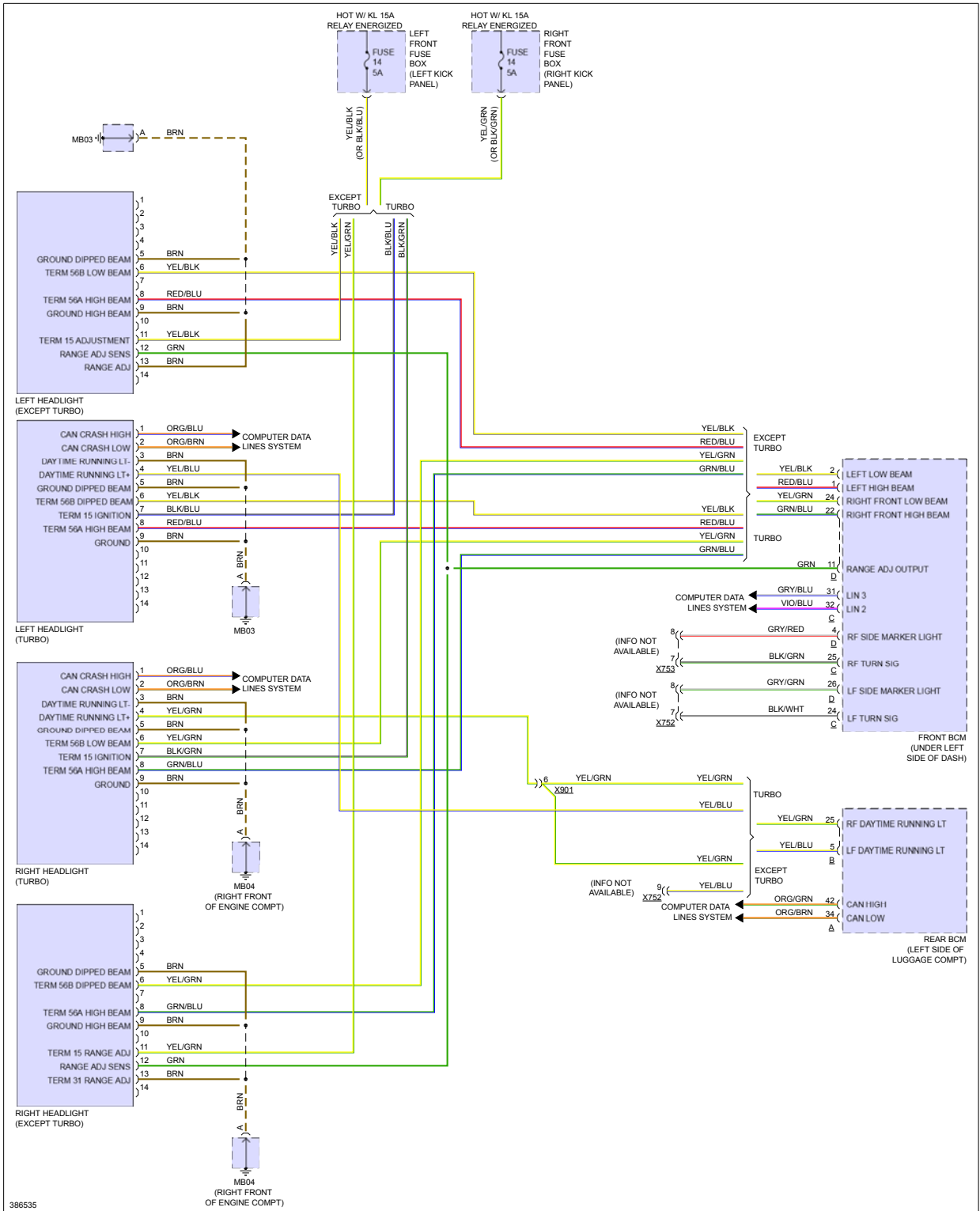
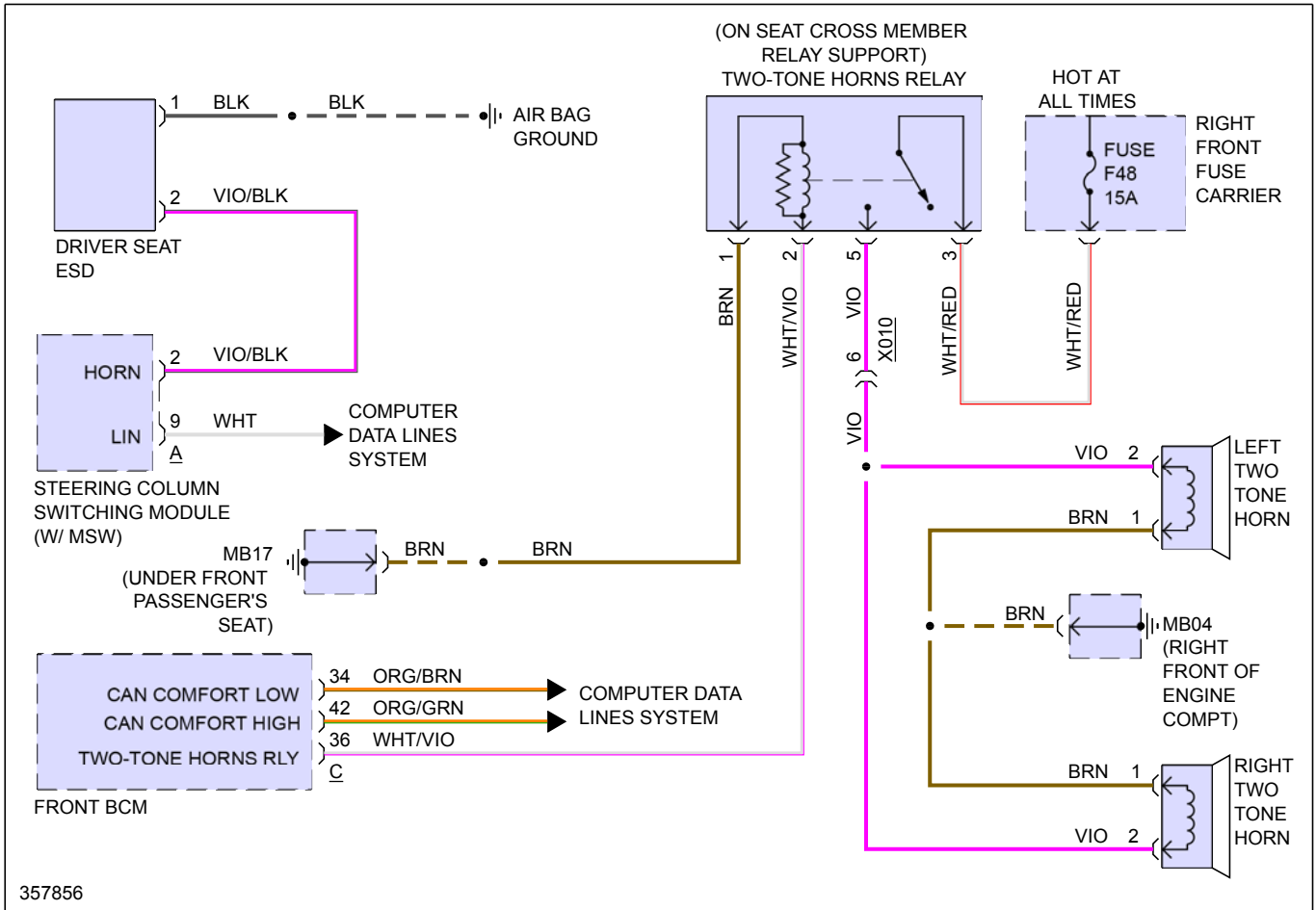

Fig 2: Headlights Circuit, W/O Cornering Headlights



# HORN

Fig 1: Horn Circuit



# INSTRUMENT CLUSTER

Fig 1: Instrument Cluster Circuit

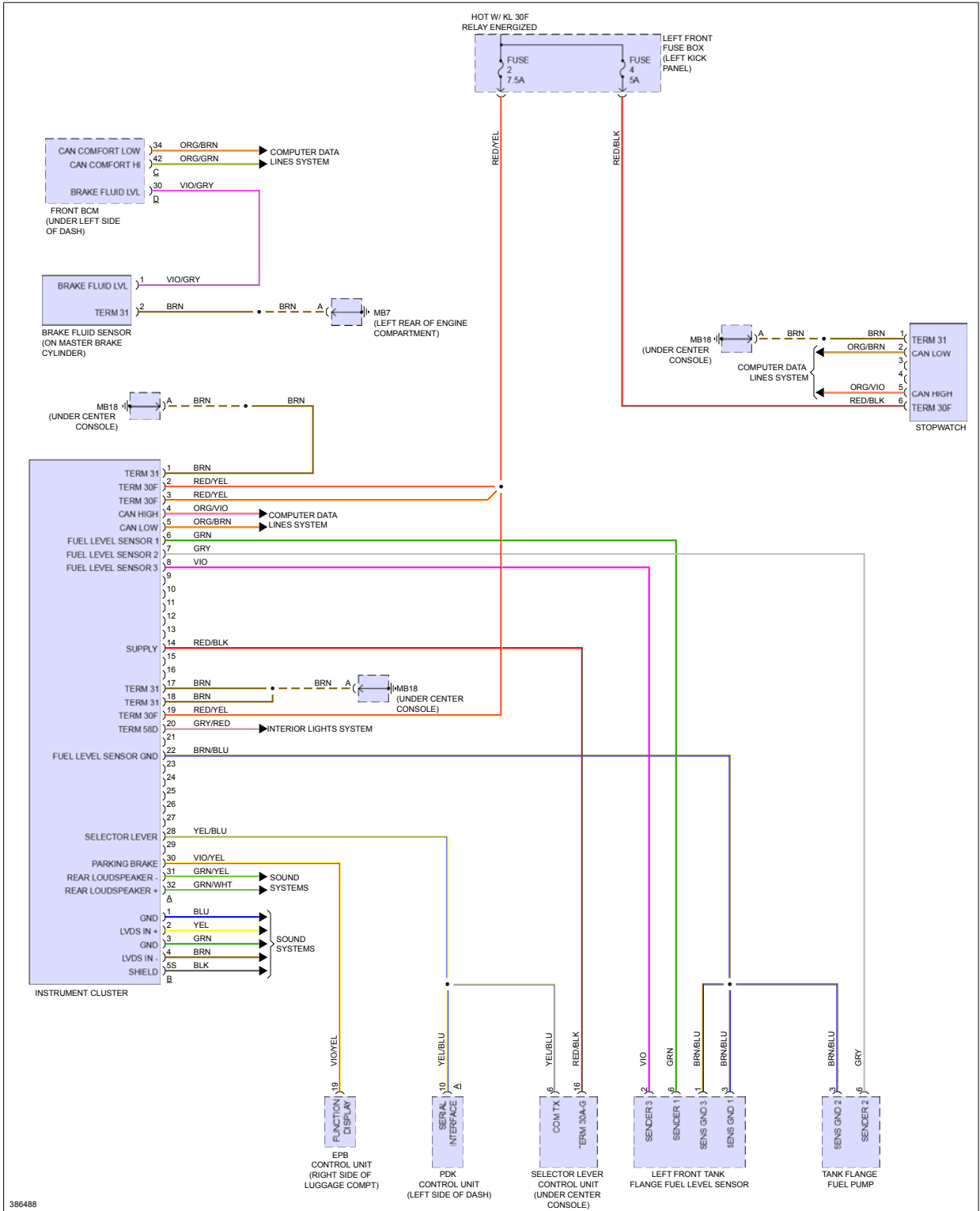
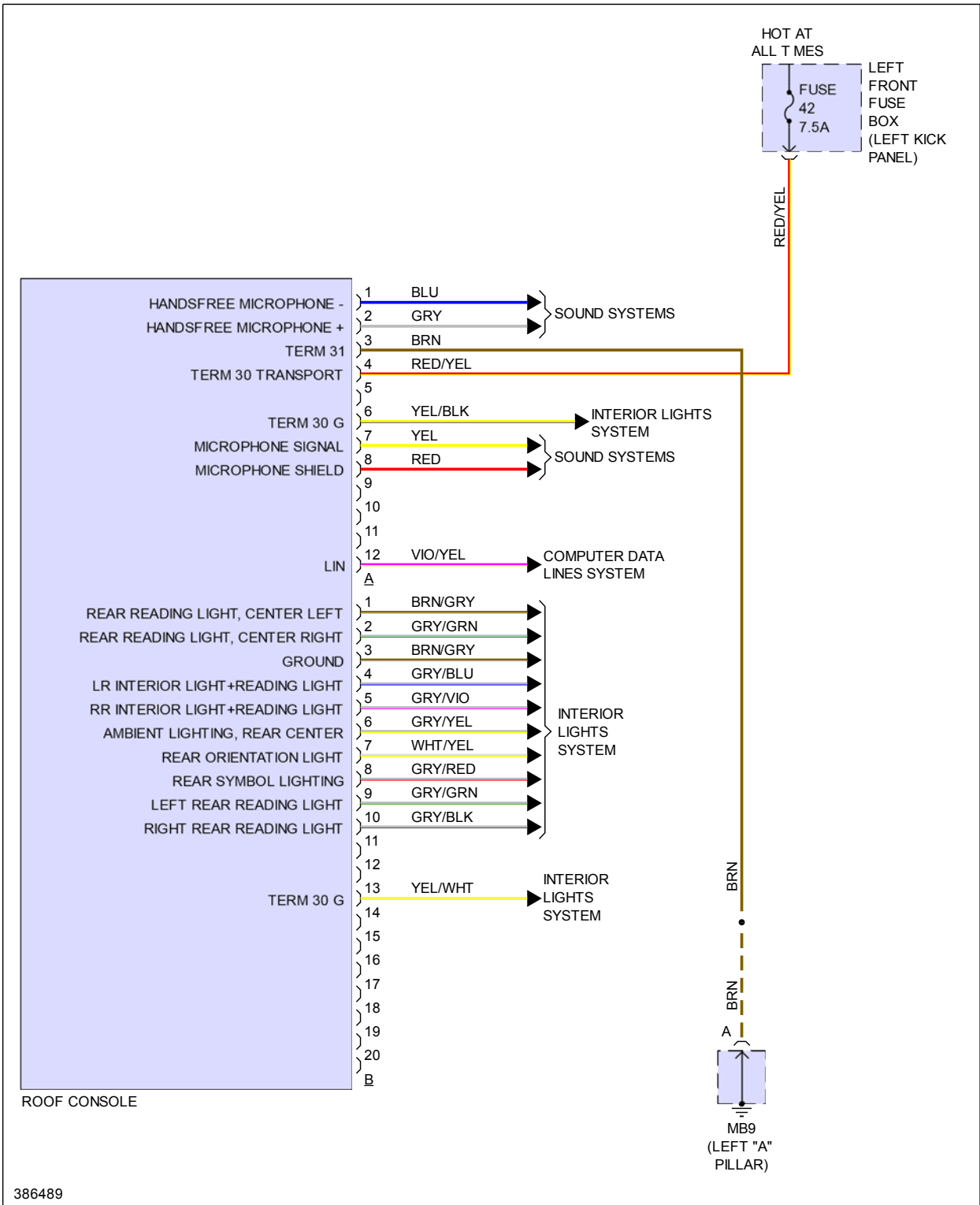



Fig 2: Overhead Console Circuit



# INTERIOR LIGHTS

Fig 1: Interior Lights Circuit (1 of 5)

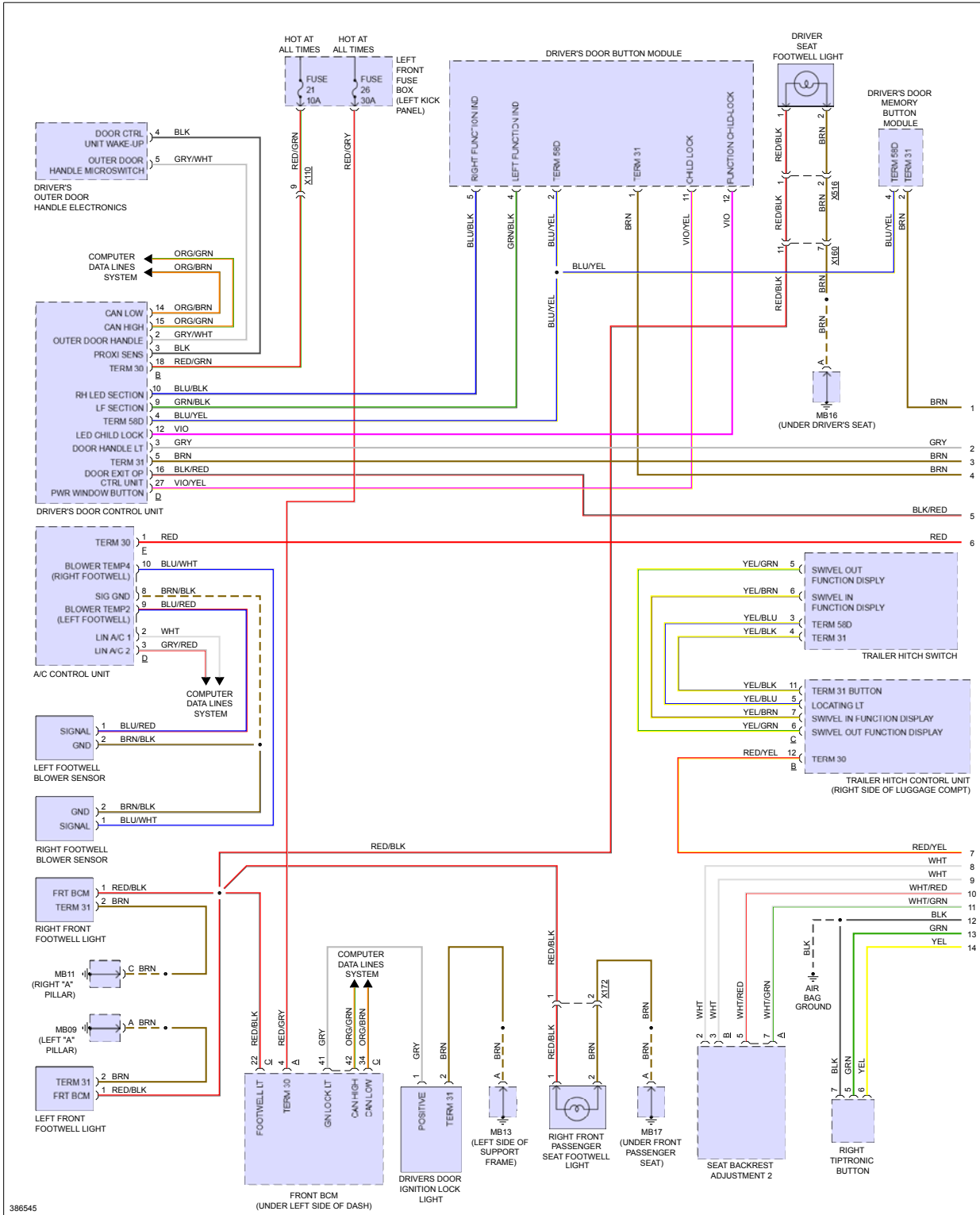

Fig 2: Interior Lights Circuit (2 of 5)

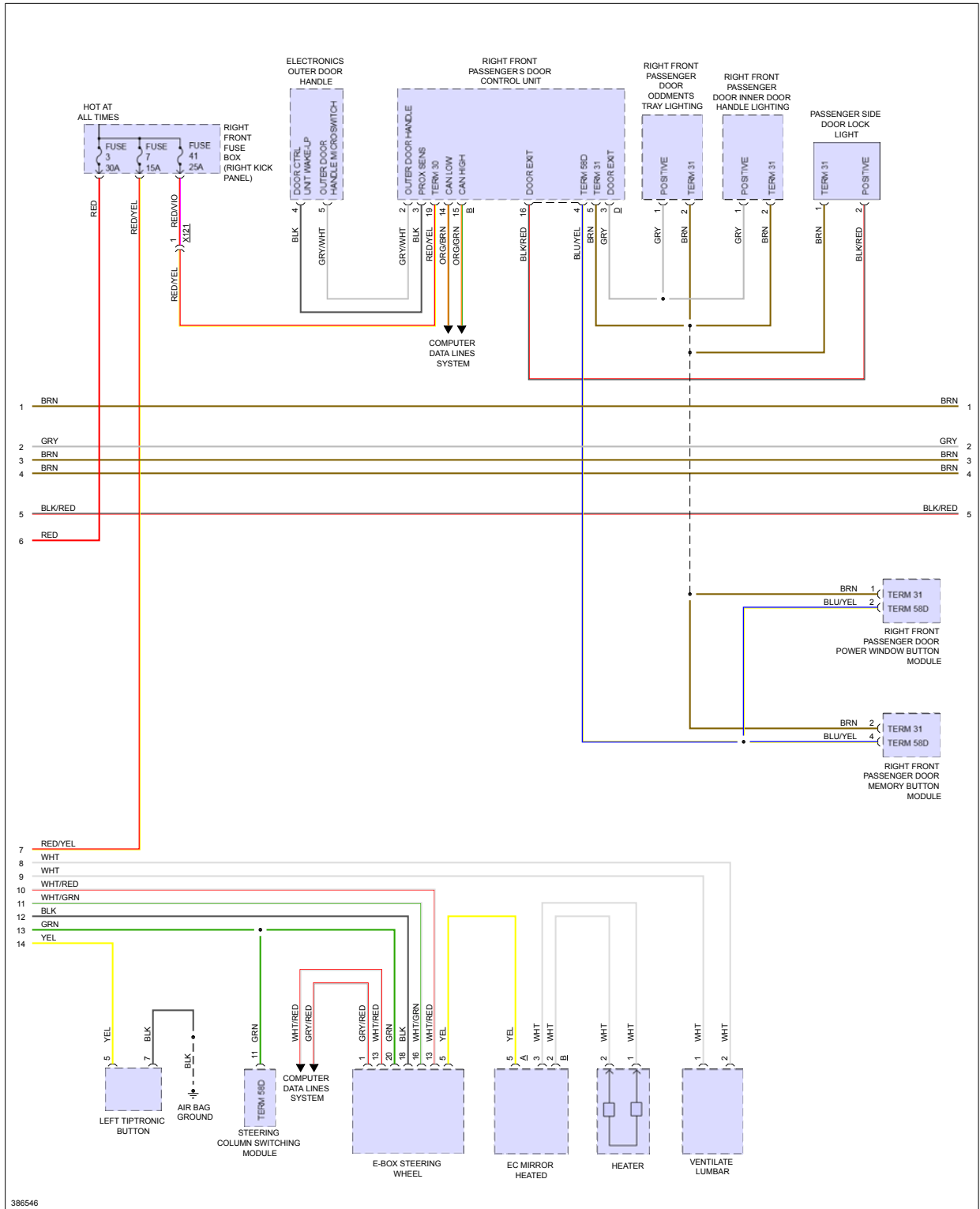

Fig 3: Interior Lights Circuit (3 of 5)

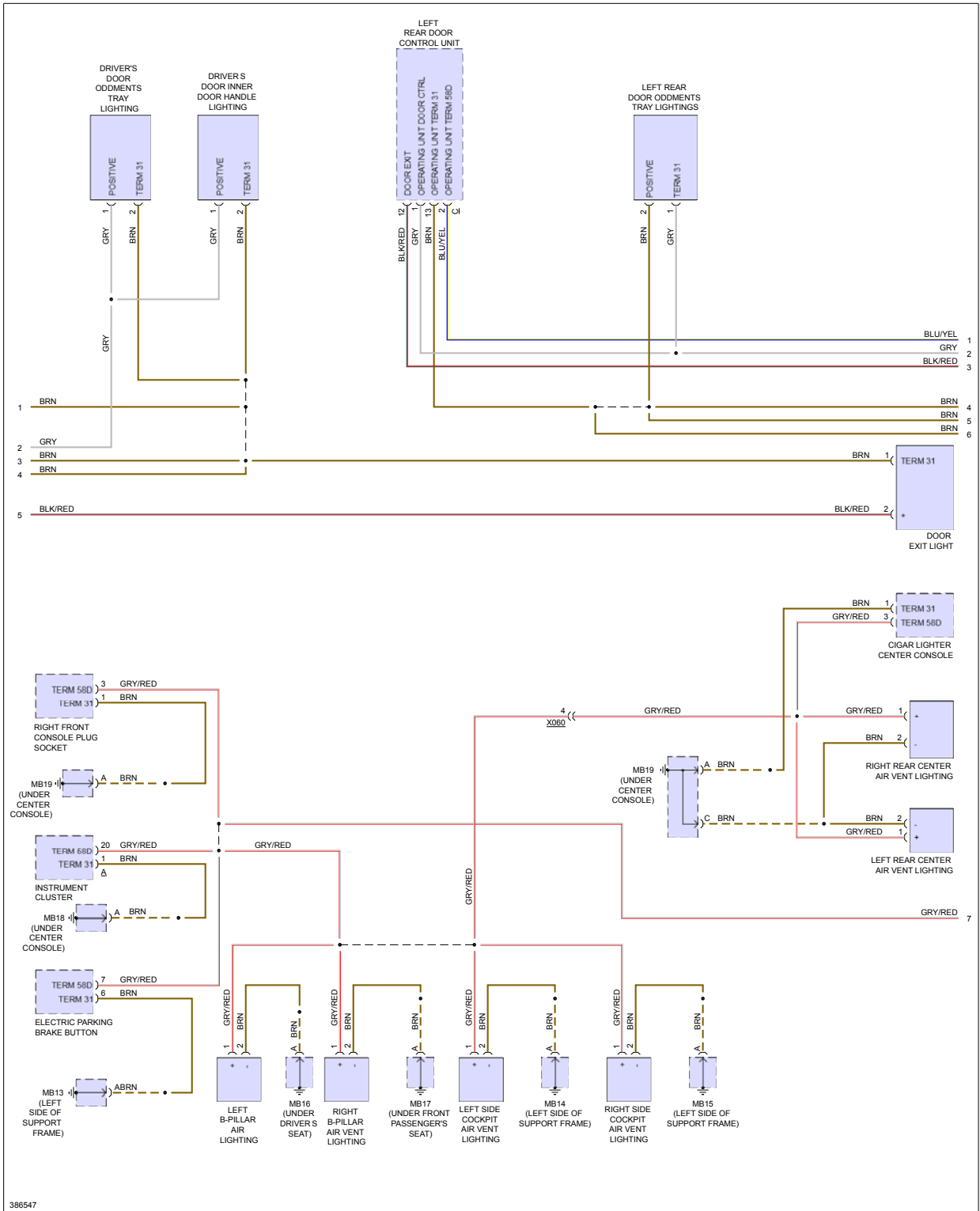

Fig 4: Interior Lights Circuit (4 of 5)

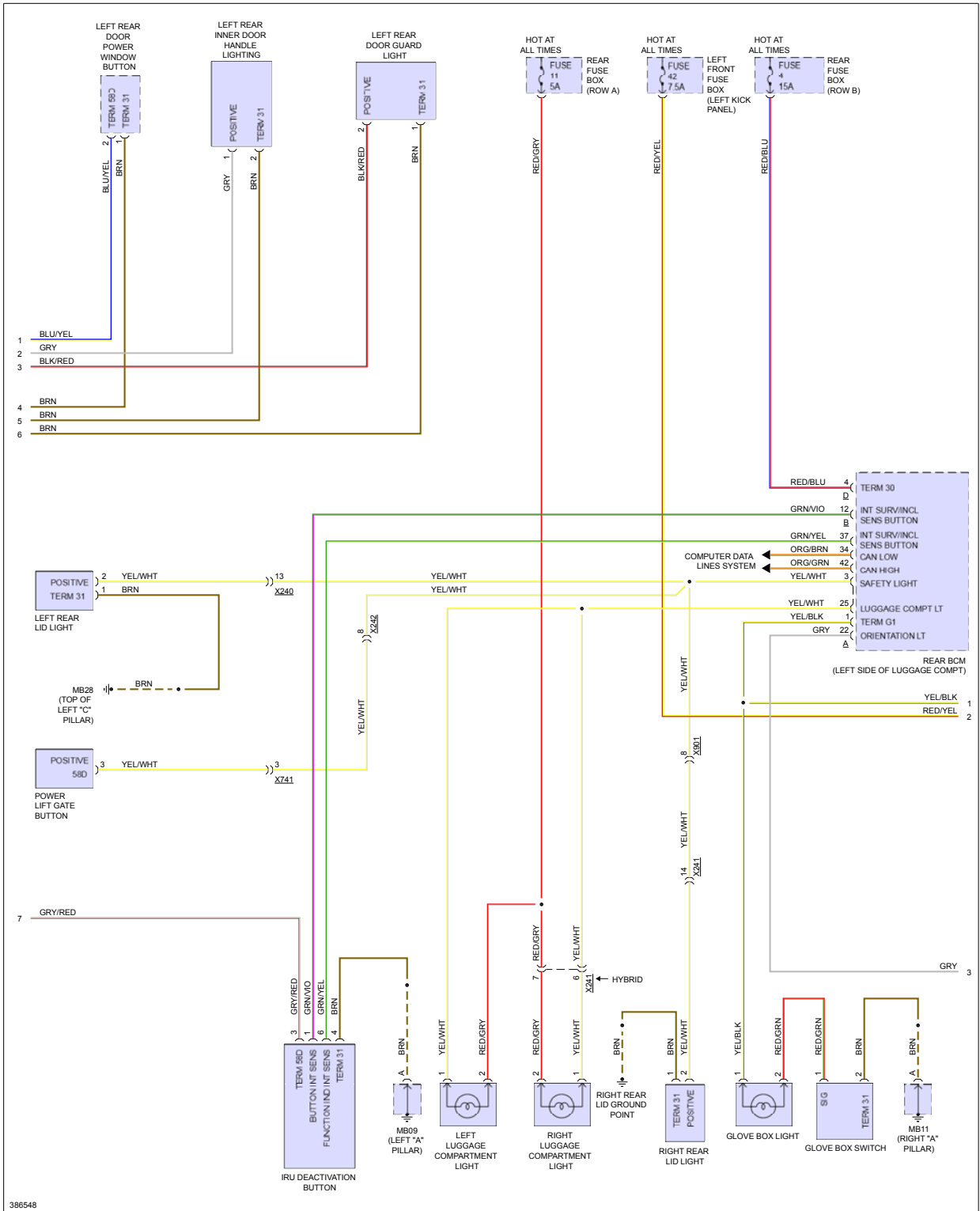
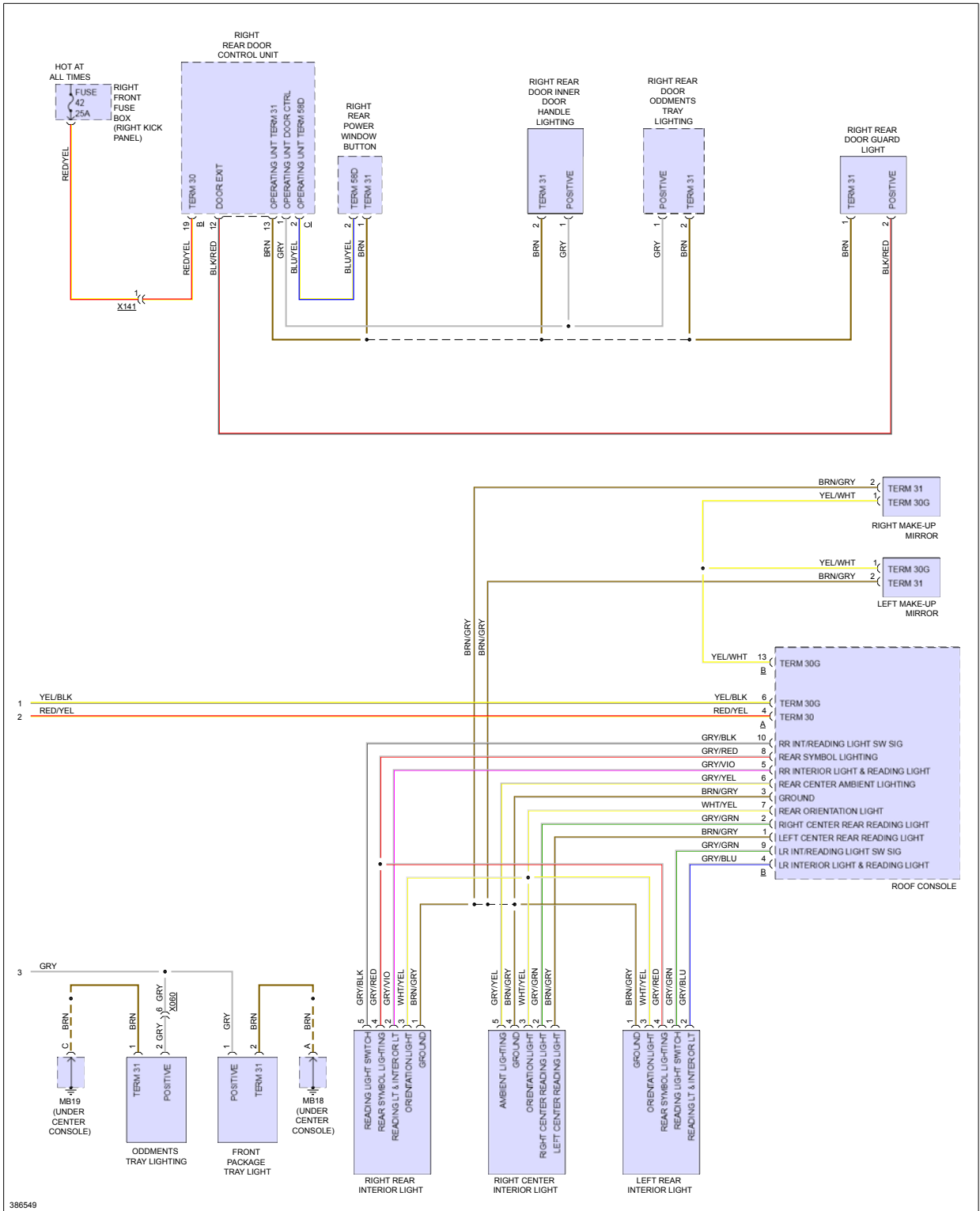

Fig 5: Interior Lights Circuit (5 of 5)



# MEMORY SYSTEMS

Fig 1: Driver's Memory Seat Circuit, Except Sport Comfort

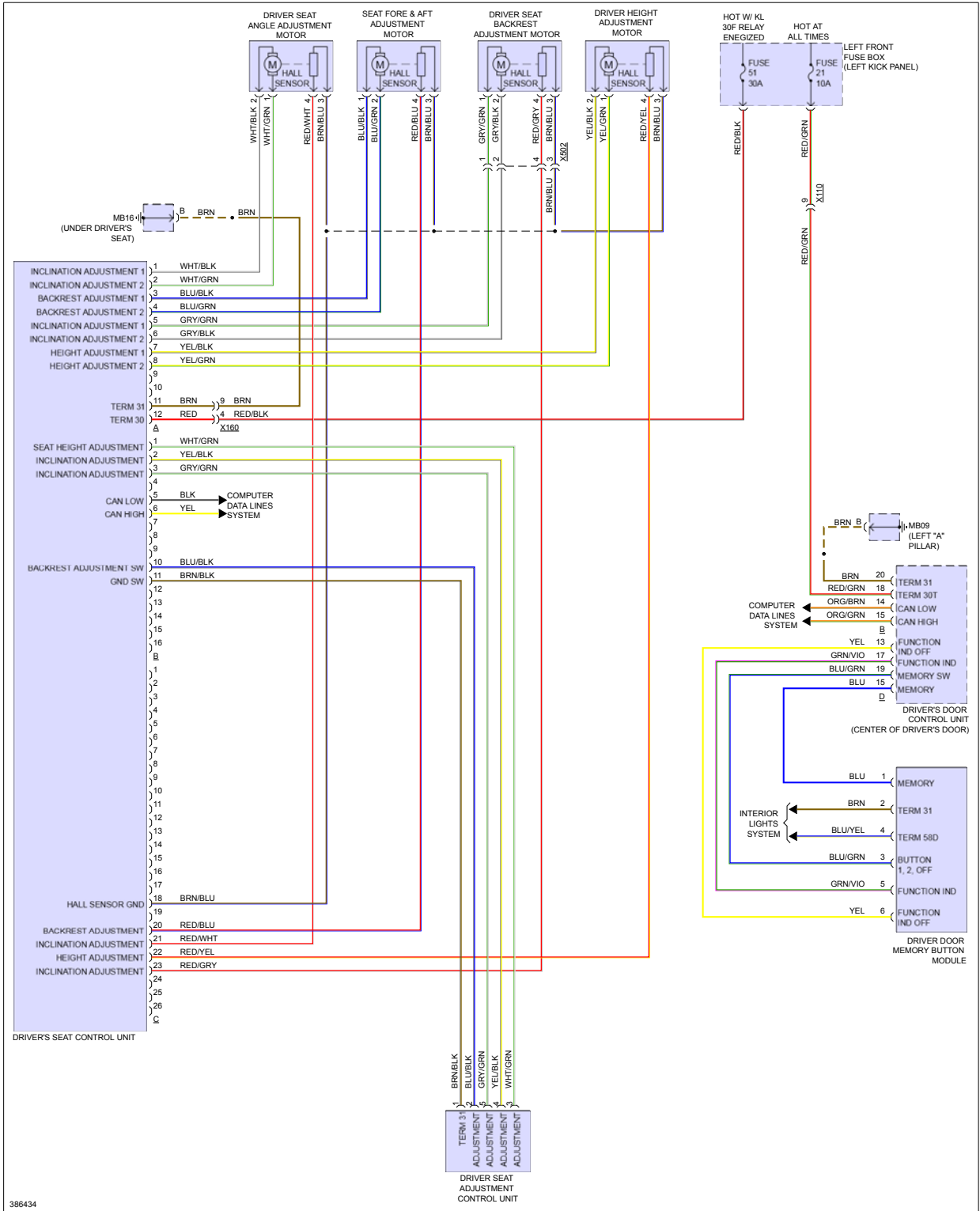

Fig 2: Driver's Memory Seat Circuit, Sport Comfort

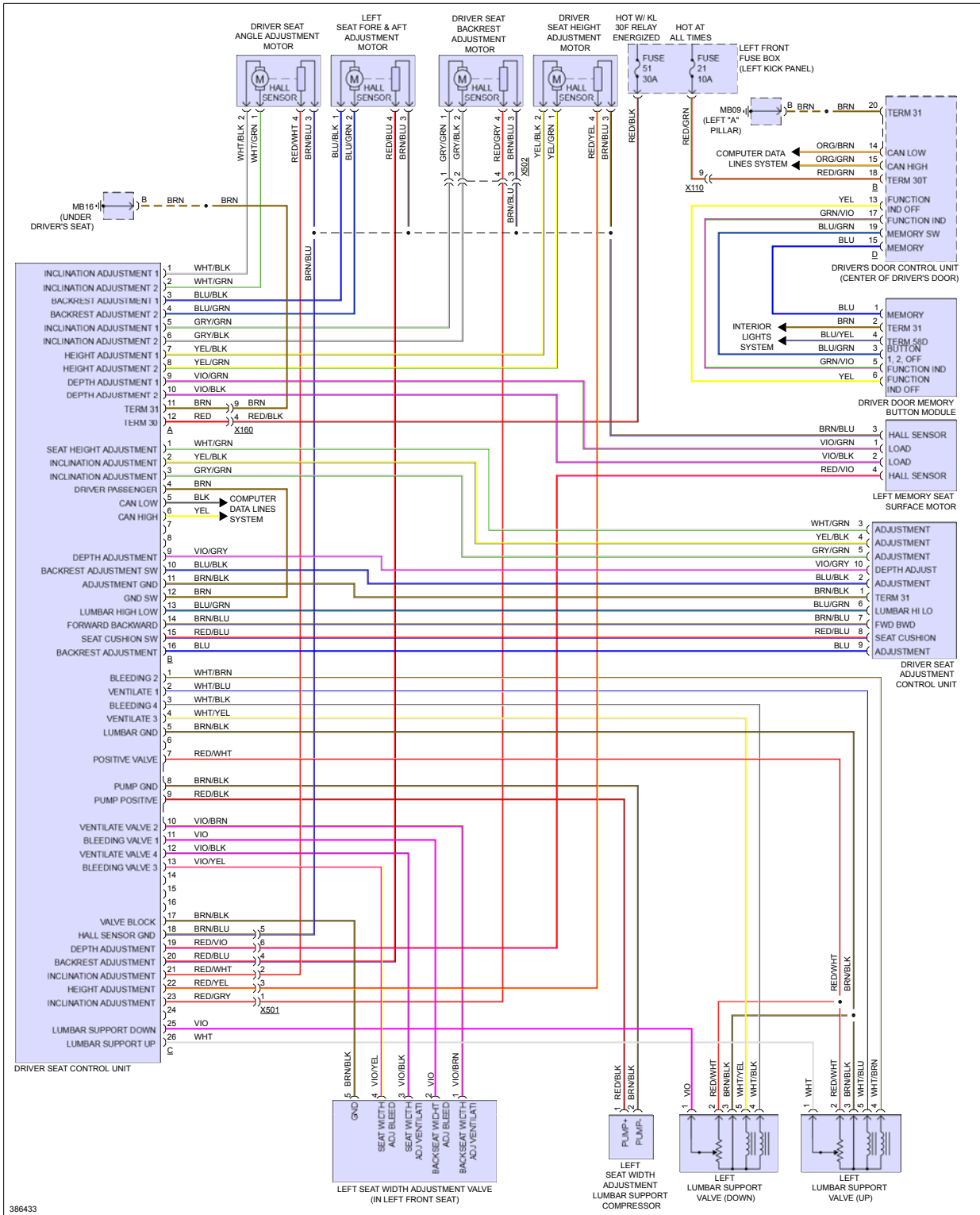



Fig 3: Memory Mirrors Circuit

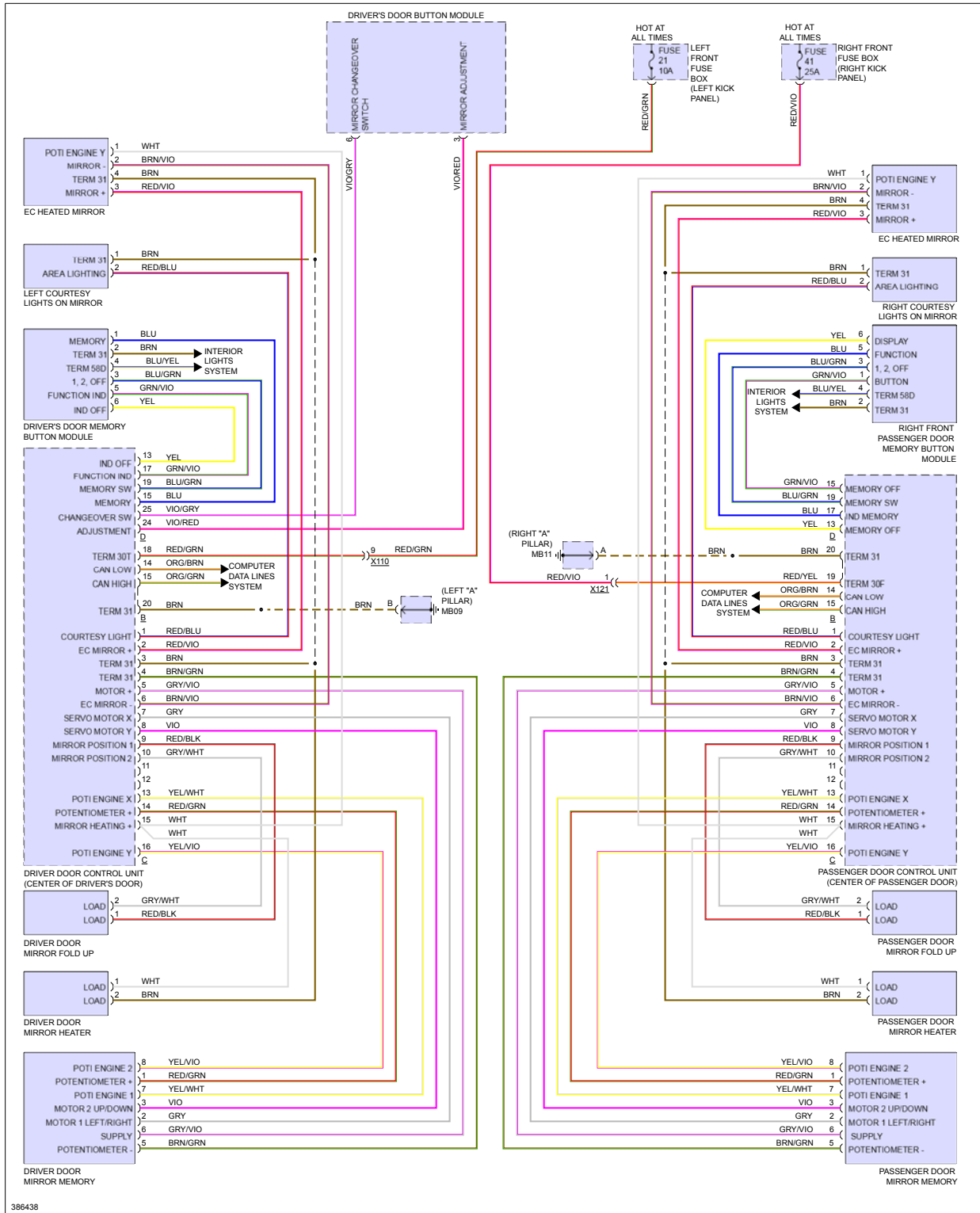

Fig 4: Passenger's Memory Seat Circuit, Except Sport Comfort

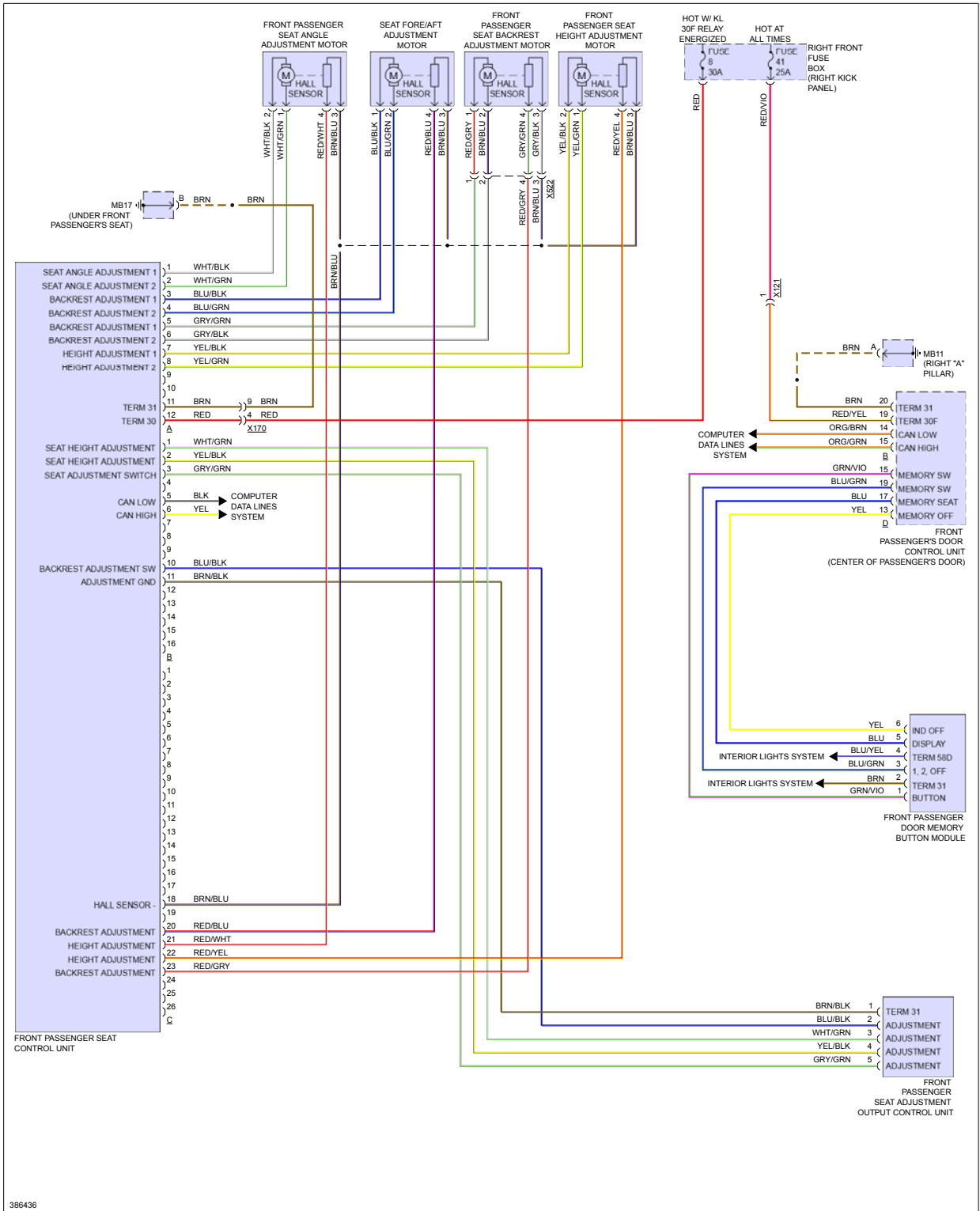

Fig 5: Passenger's Memory Seat Circuit, Sport Comfort

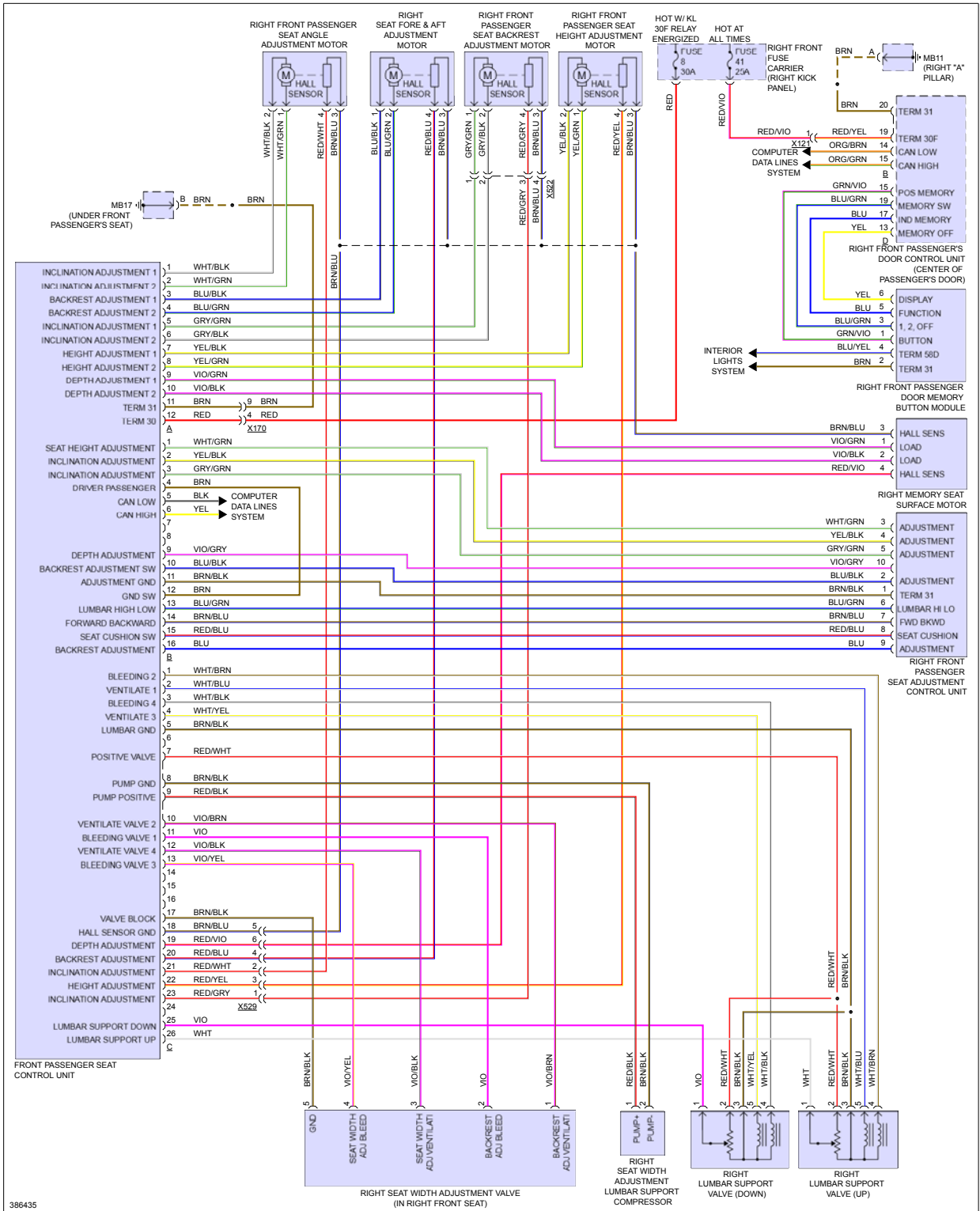
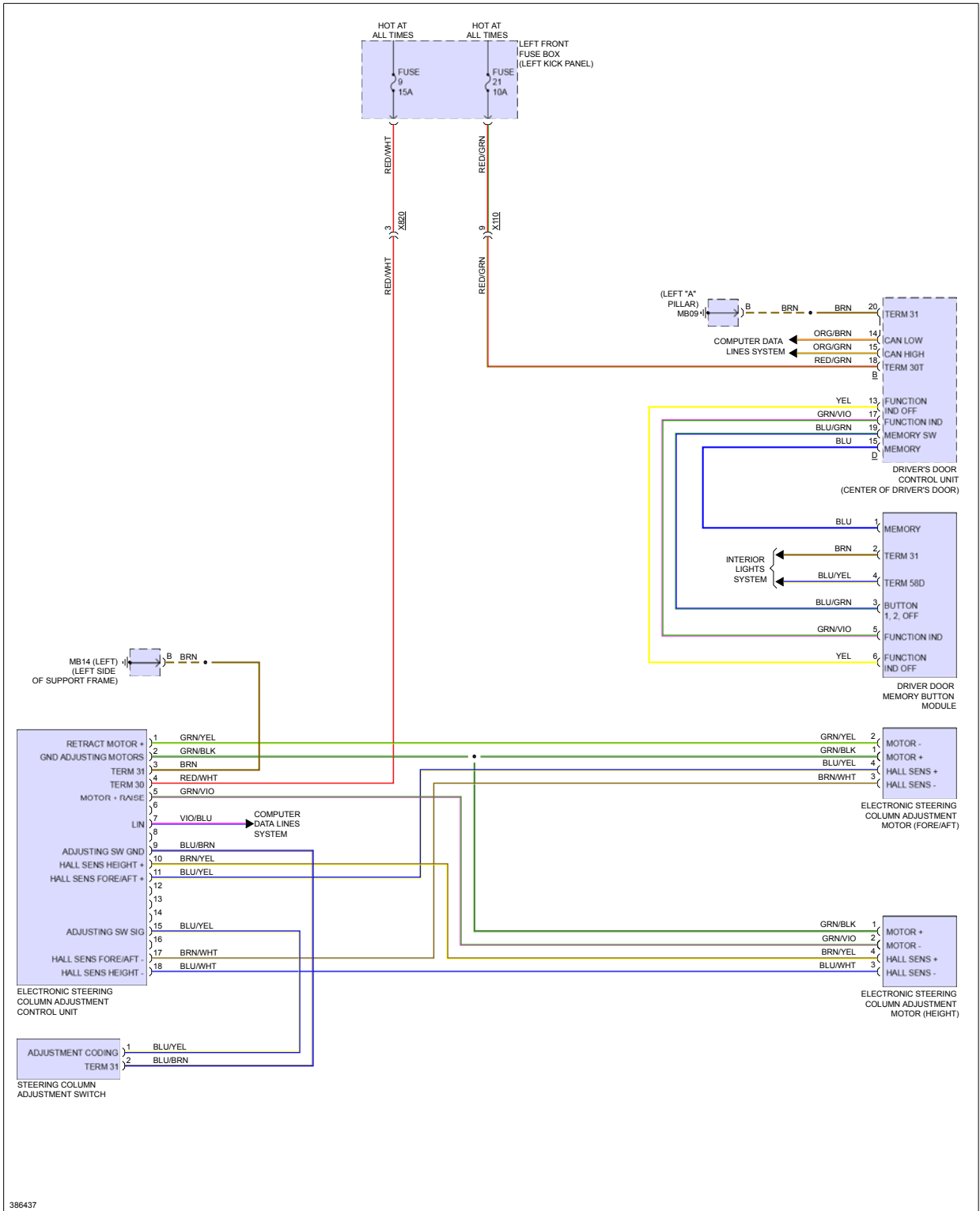

Fig 6: Steering Column Memory Circuit



# NAVIGATION

Fig 1: Lane Change Assistance Circuit

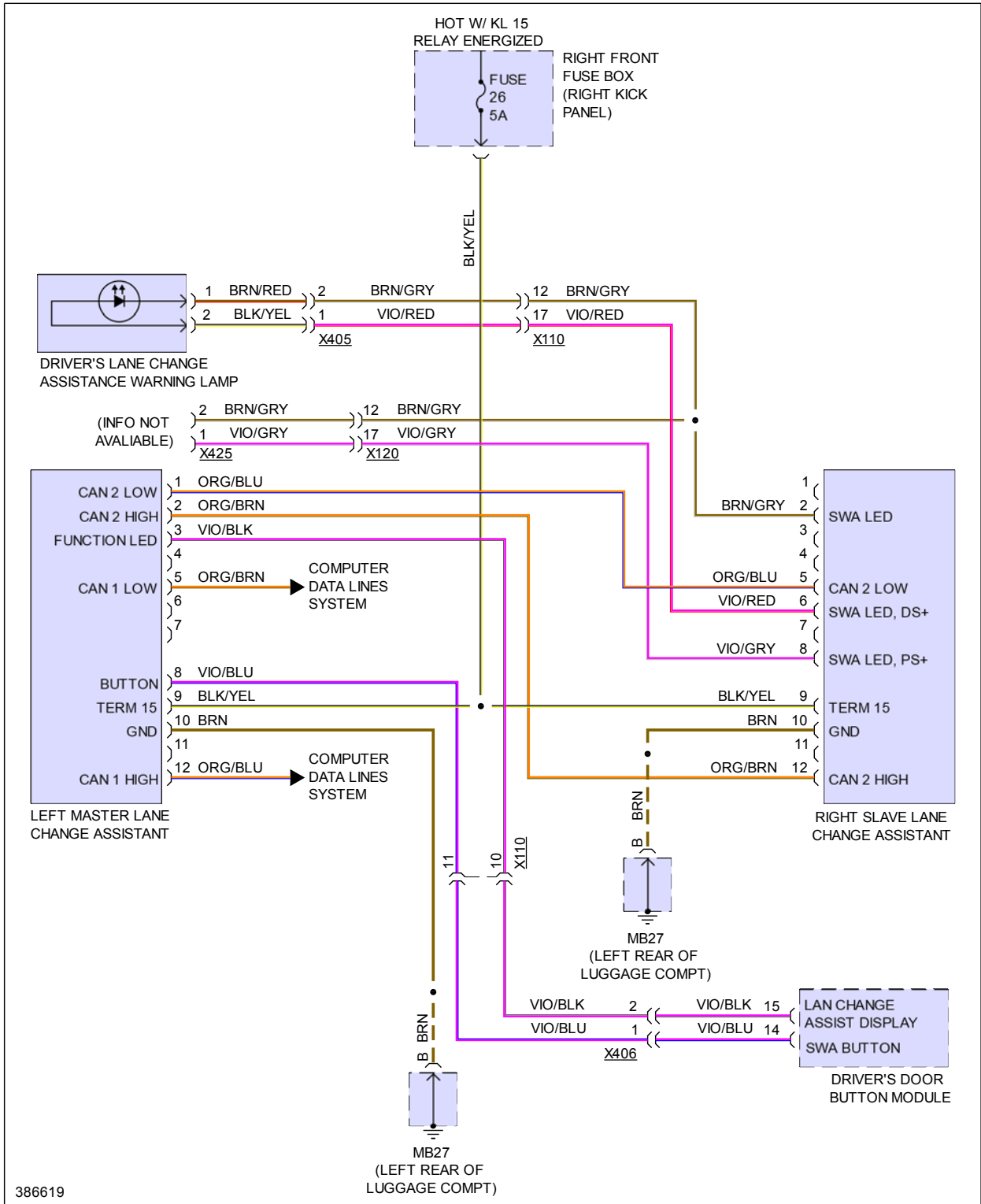

Fig 2: Navigation Circuit, W/ ASK (1 of 2)

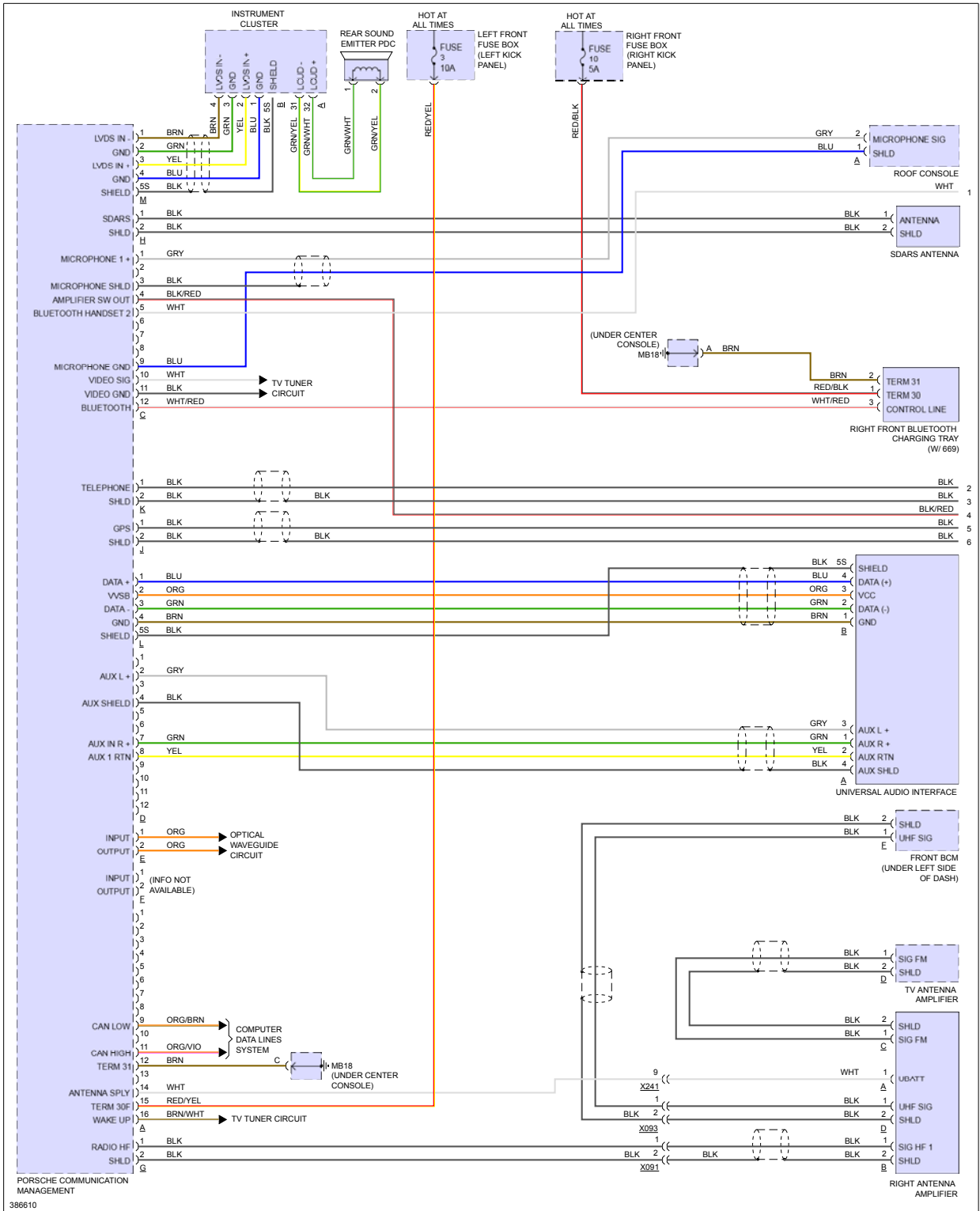

Fig 3: Navigation Circuit, W/ ASK (2 of 2)

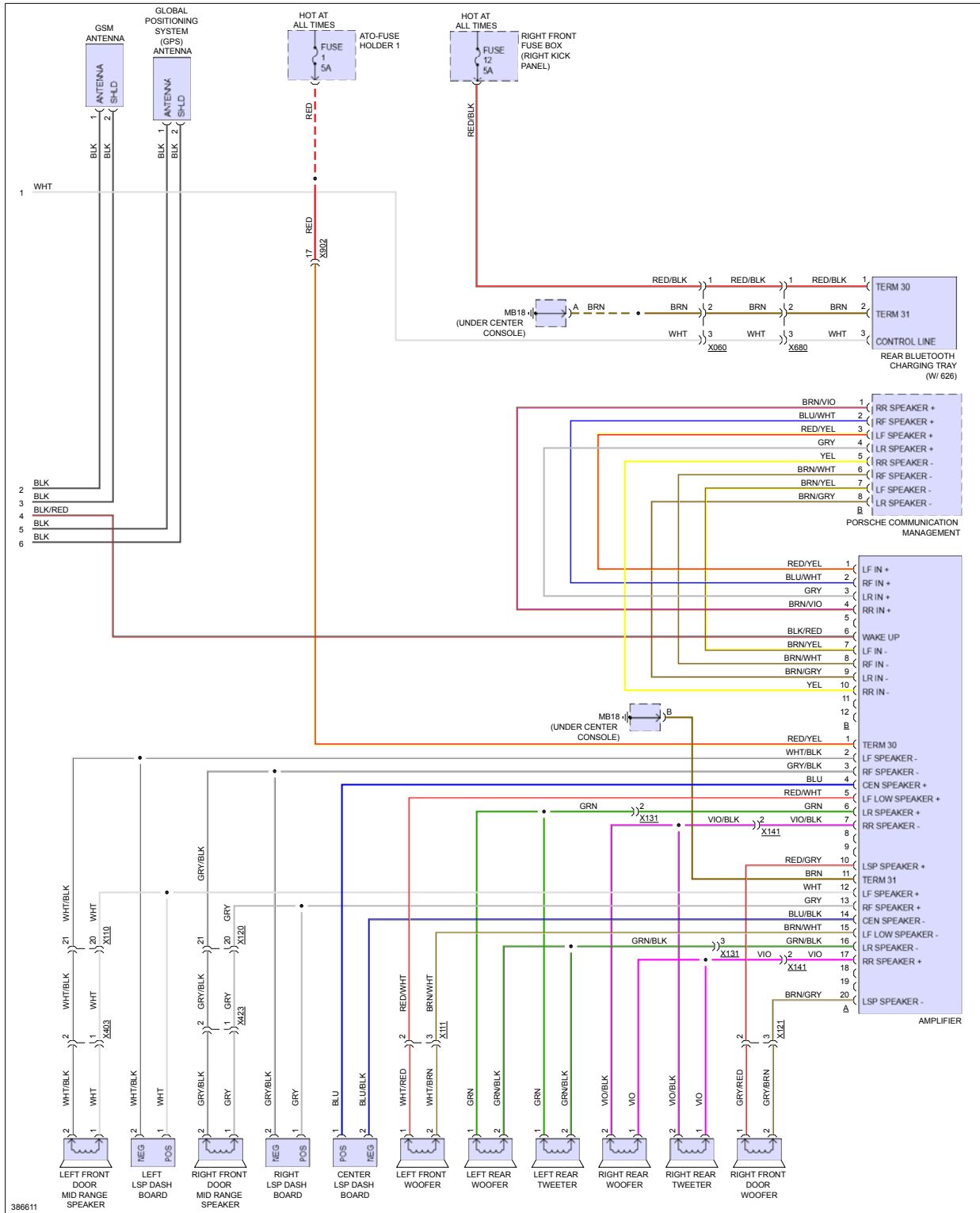

Fig 4: Navigation Circuit, W/ Bose (1 of 2)

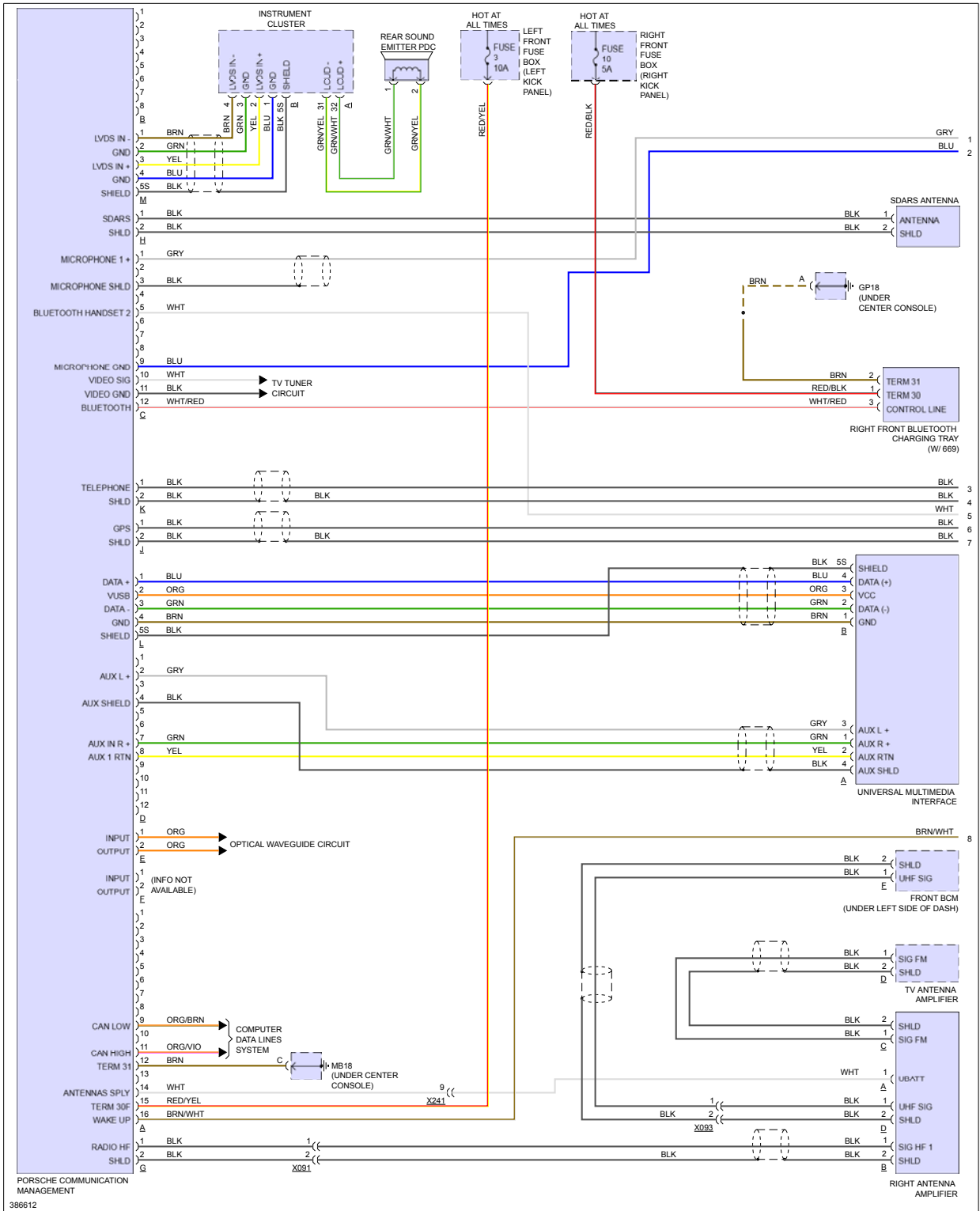



Fig 5: Navigation Circuit, W/ Bose (2 of 2)

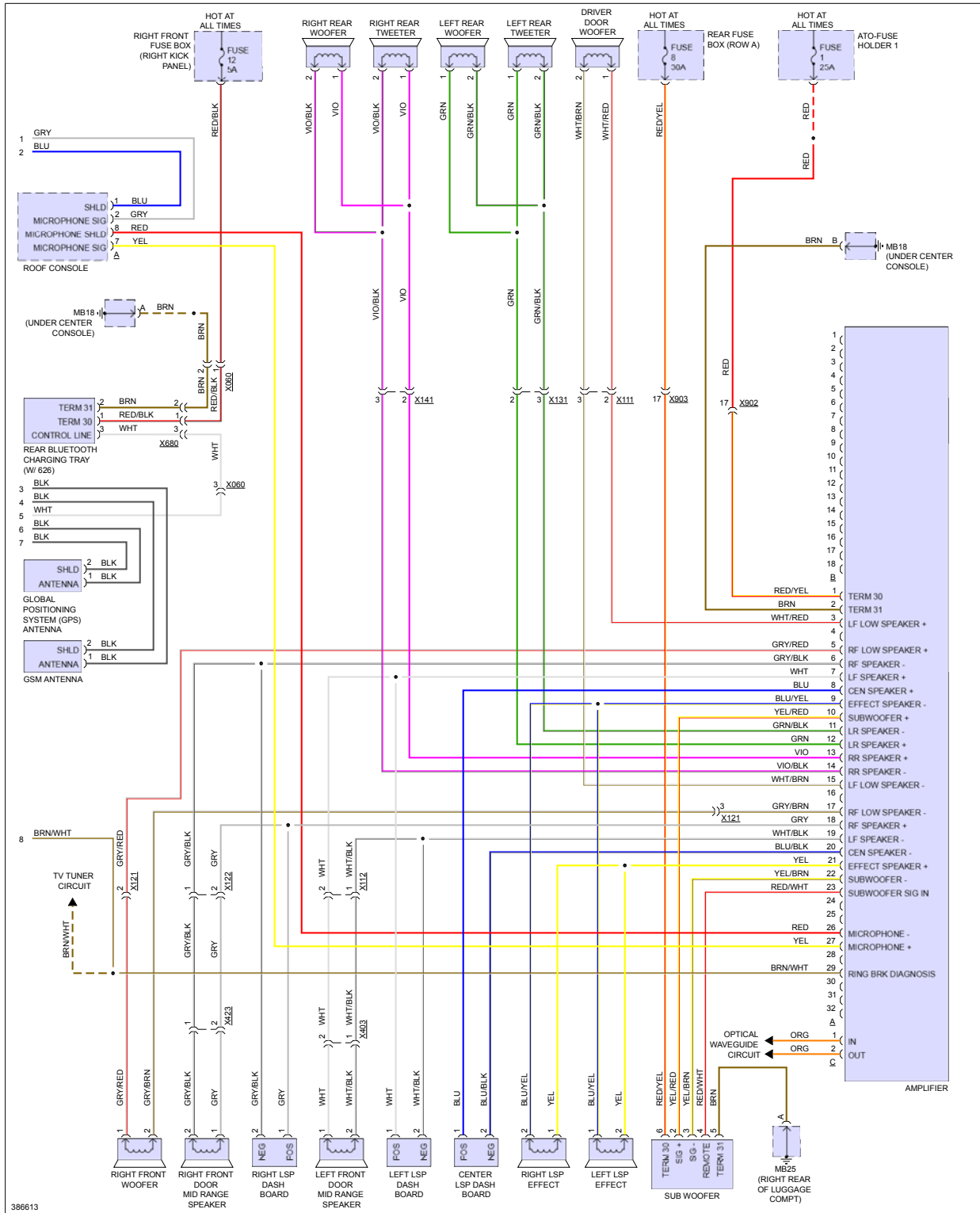

Fig 6: Navigation Circuit, W/ Burmester (1 of 3)

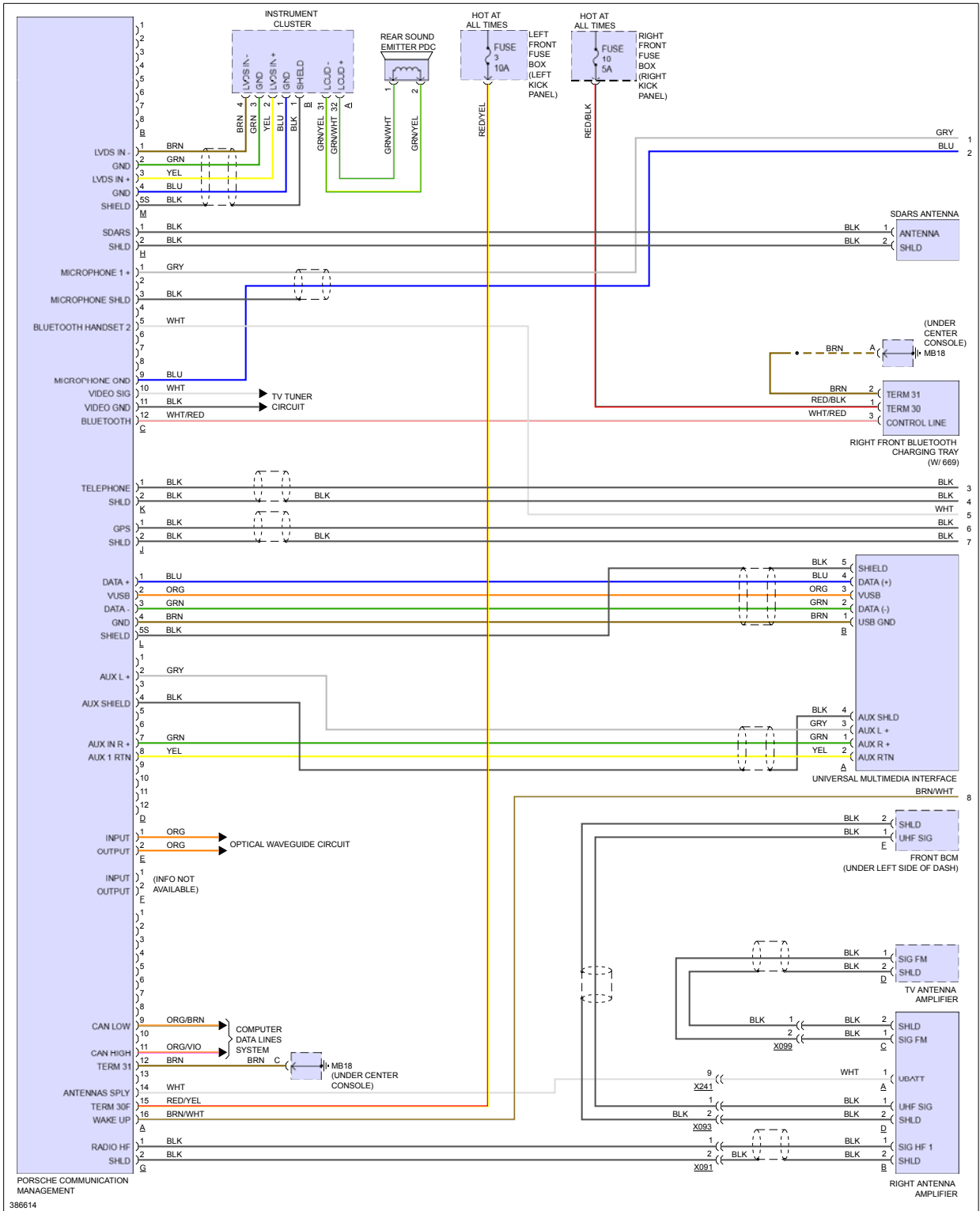

Fig 7: Navigation Circuit, W/ Burmester (2 of 3)

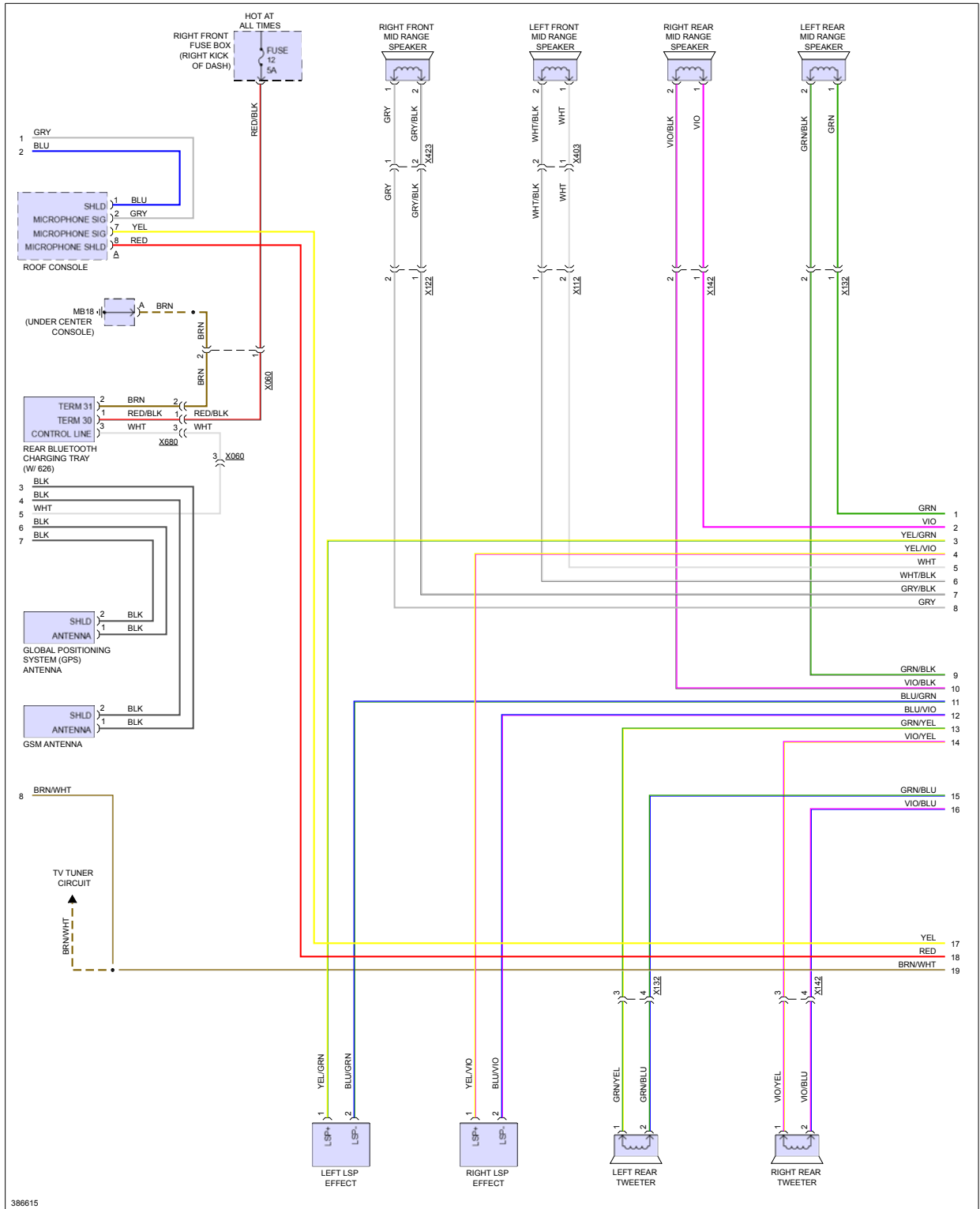



Fig 9: Parking Assistant Circuit

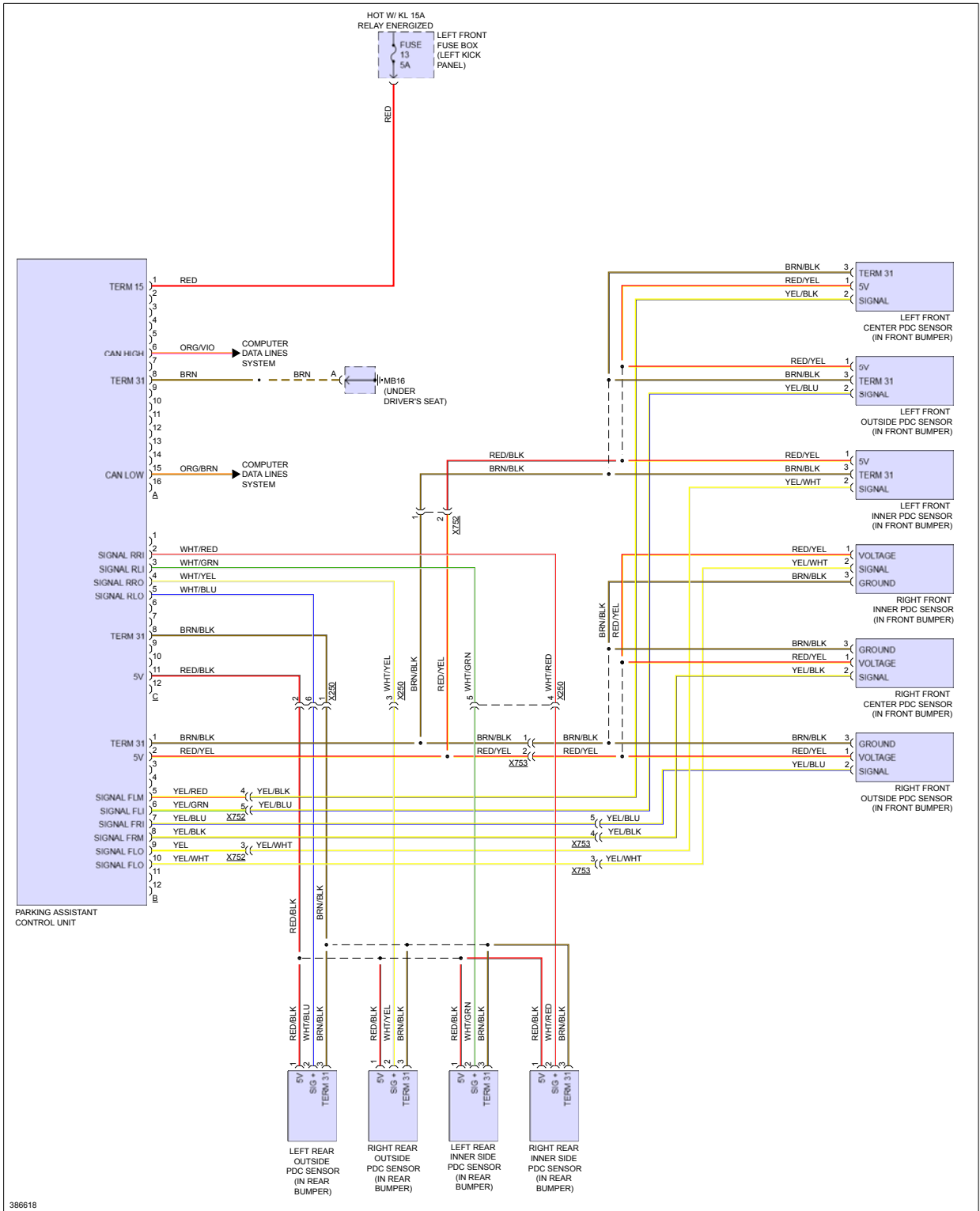





Fig 2: Power Distribution Circuit (2 of 7)

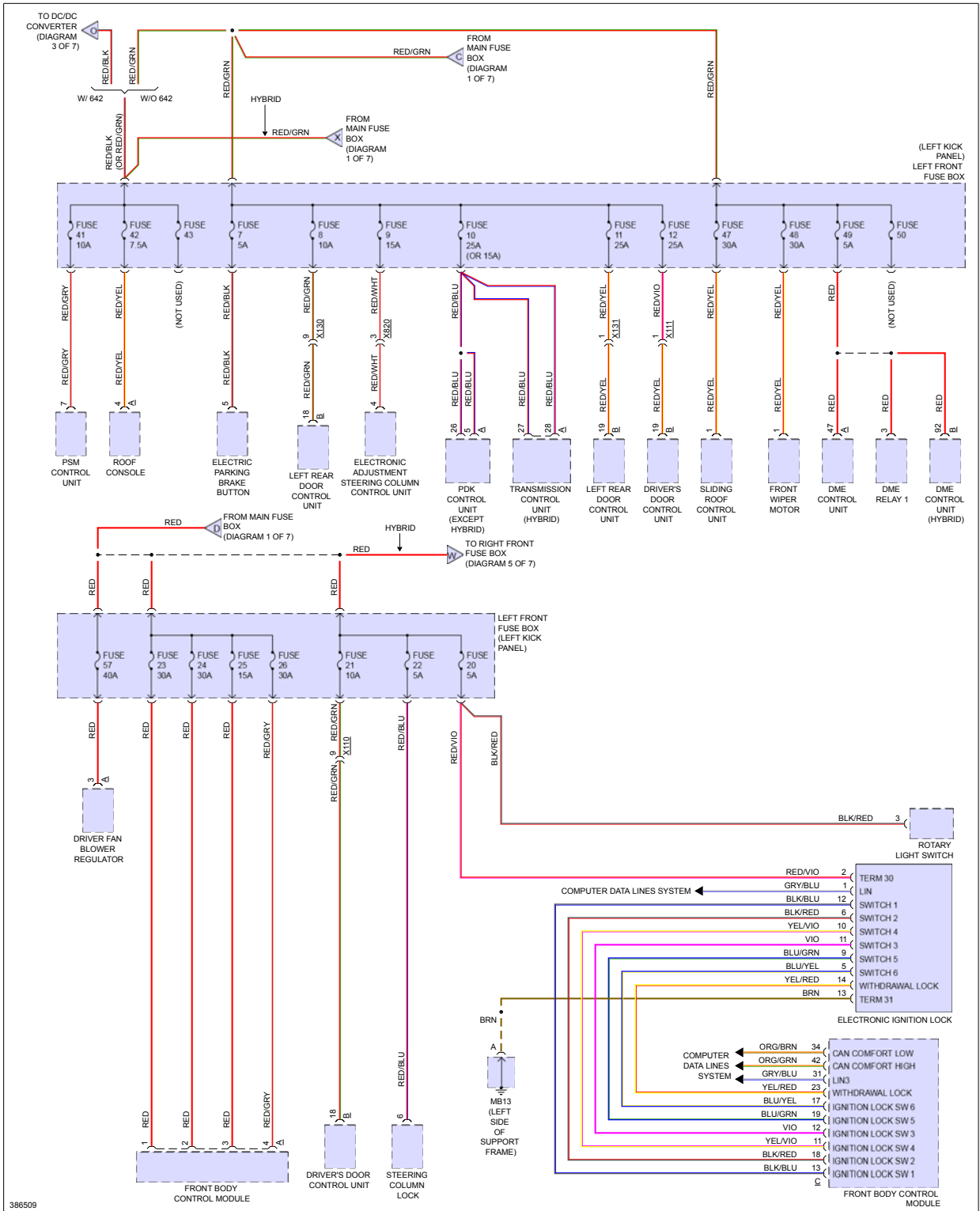



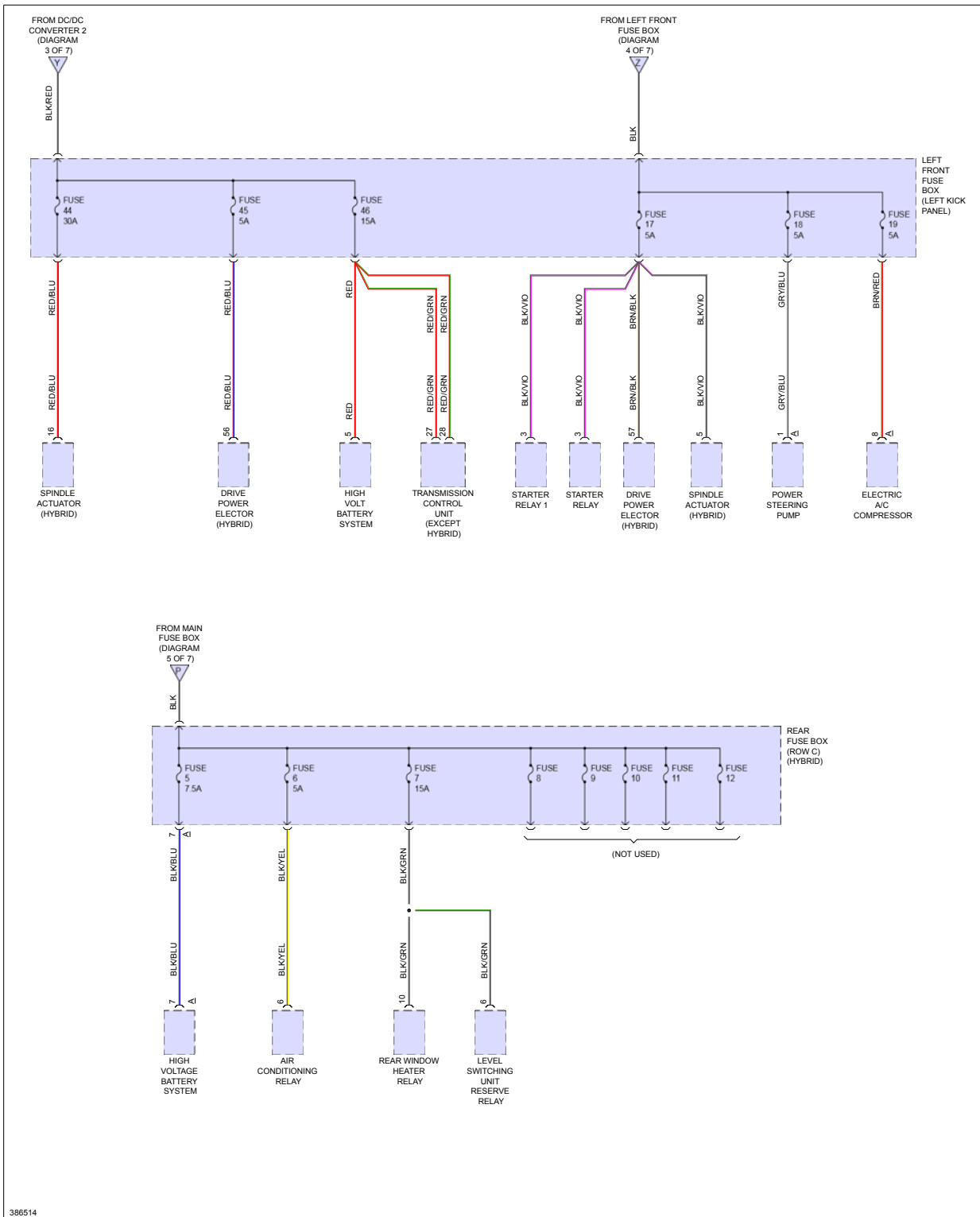





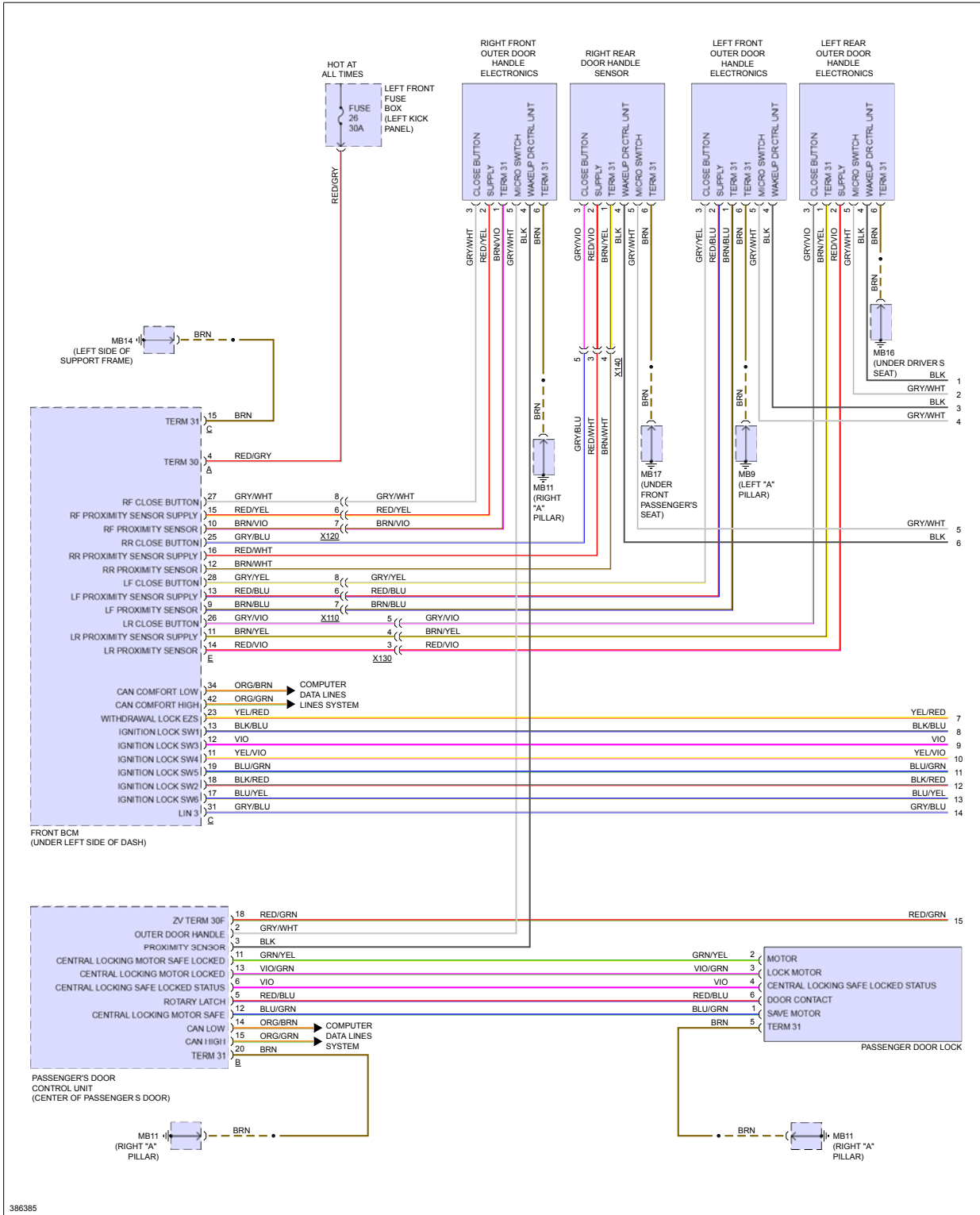

Fig 7: Power Distribution Circuit (7 of 7)



# POWER DOOR LOCKS

Fig 1: Power Door Locks Circuit (1 of 3)









# POWER MIRRORS

Fig 1: Power Mirrors Circuit

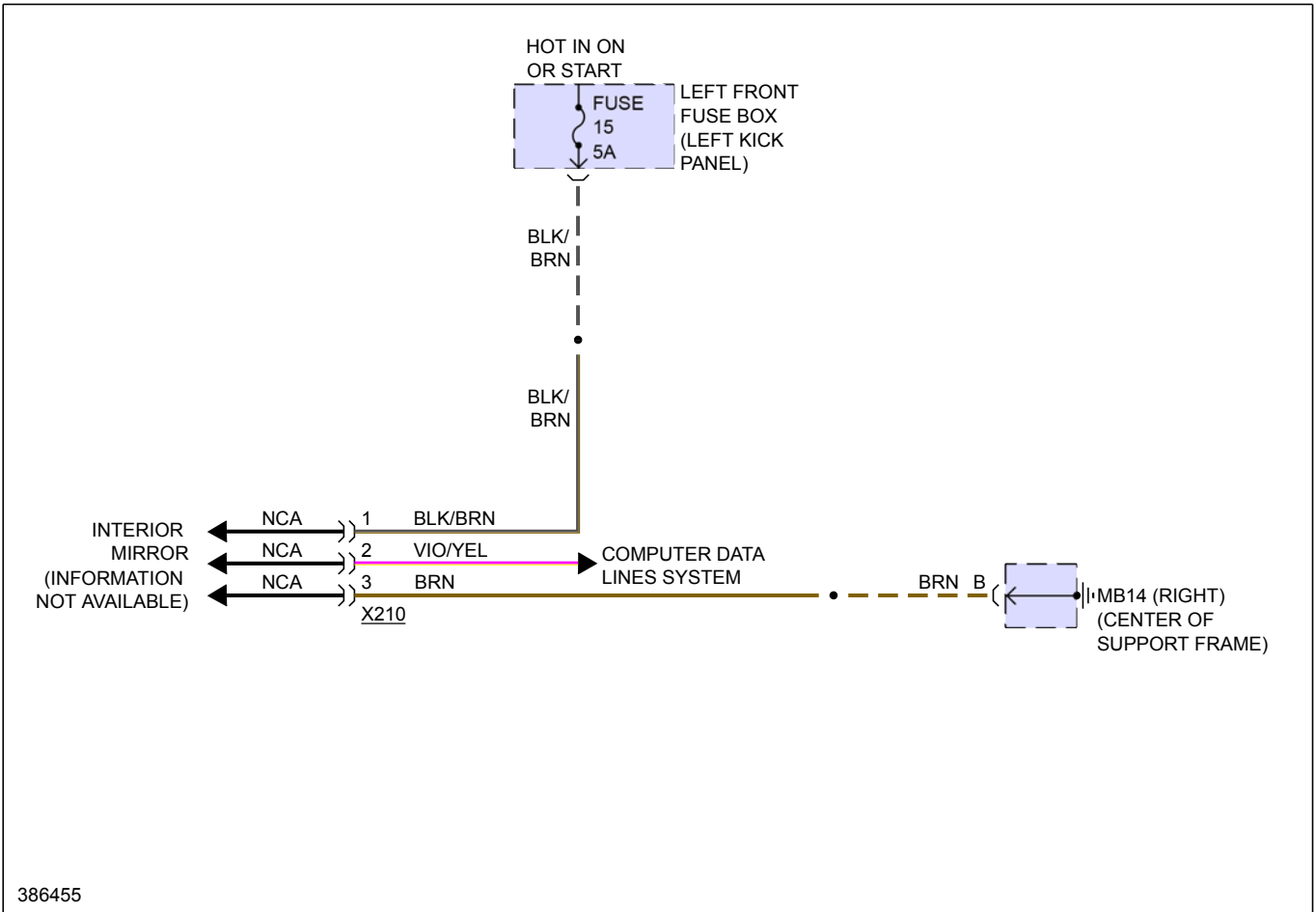

# POWER SEATS

Fig 1: Front Heated Seats Circuit, W/ Passenger Power Seats

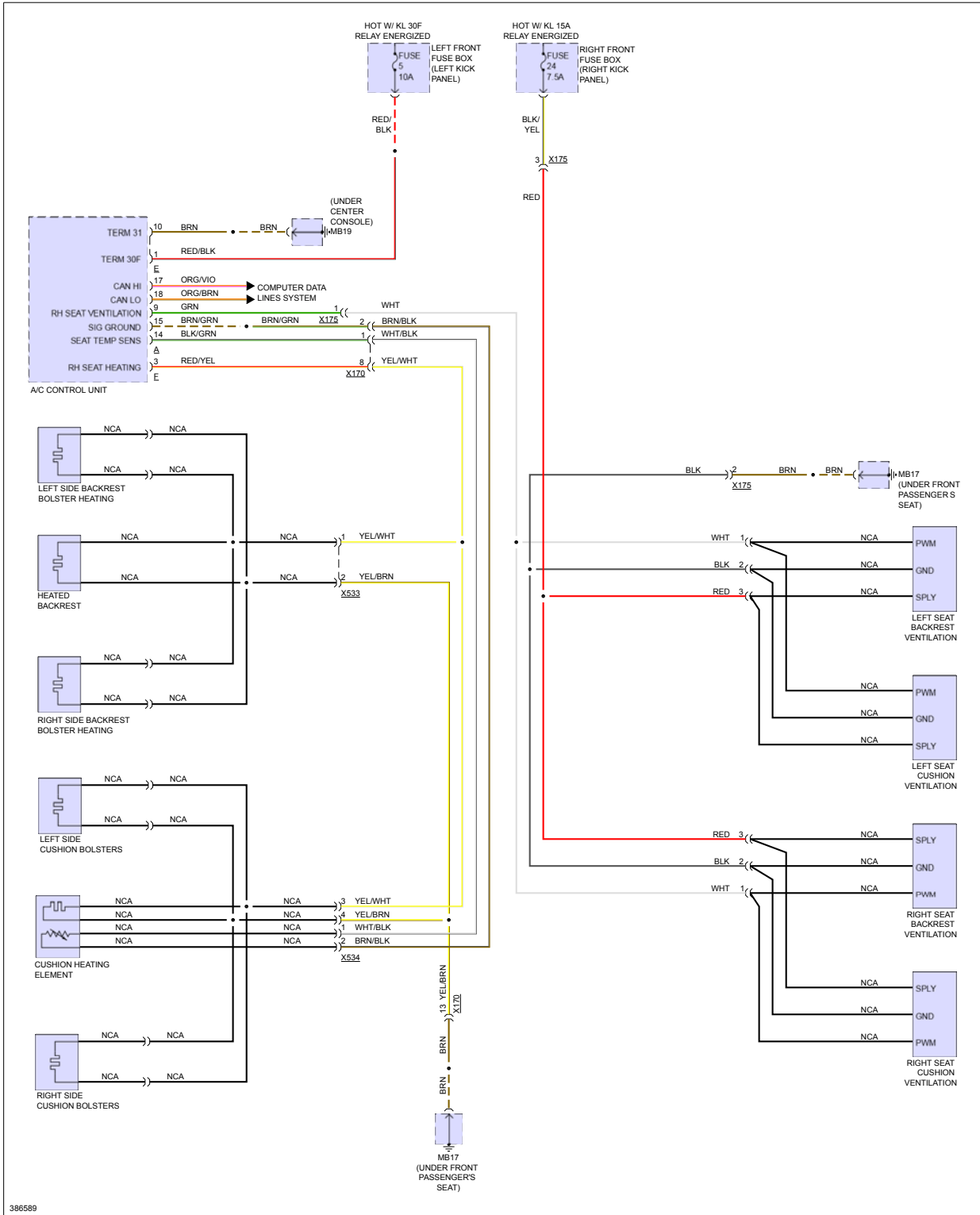

Fig 2: Front Heated Seats Circuit, W/O Passenger Power Seats

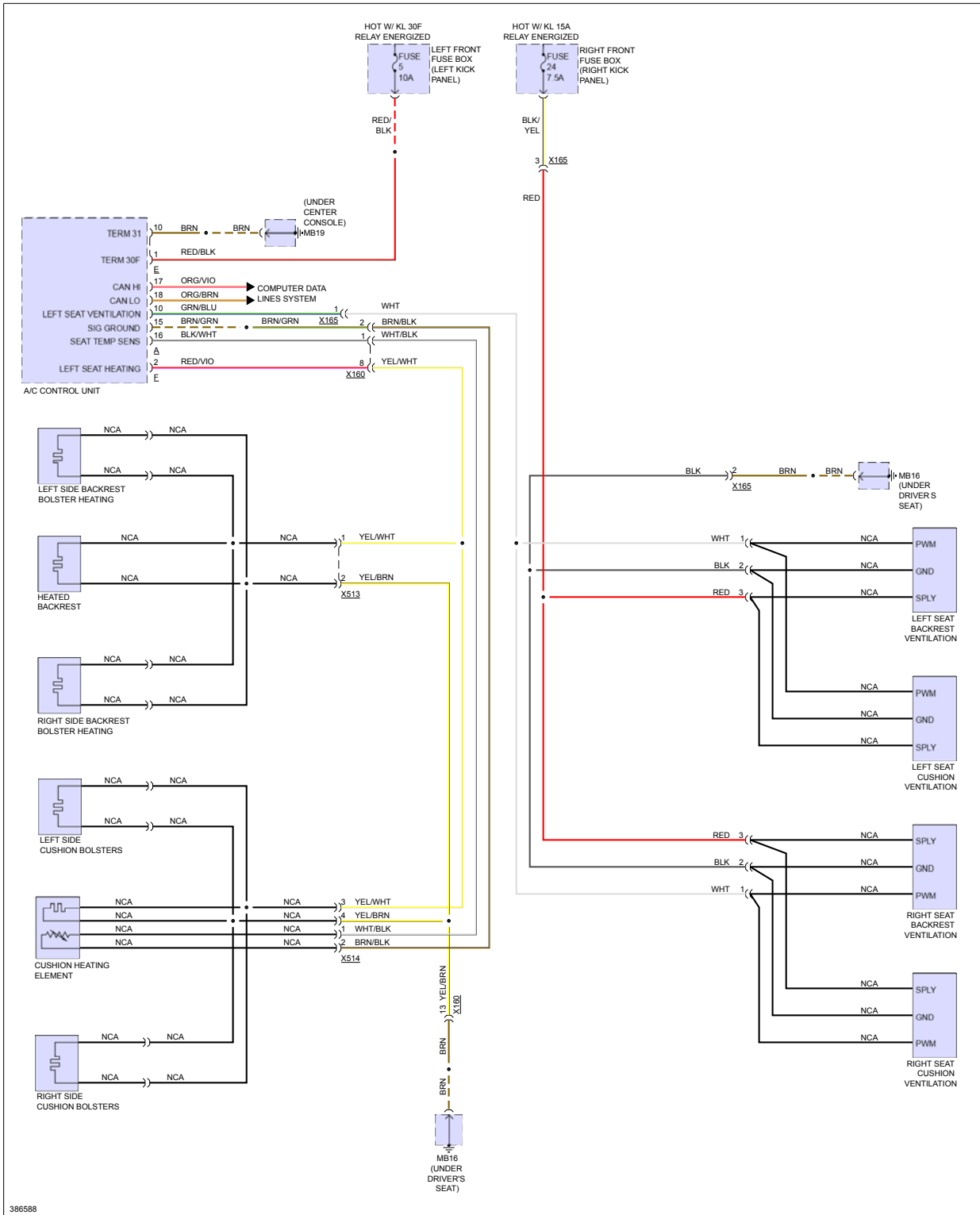

Fig 3: Passenger Power Seat Circuit

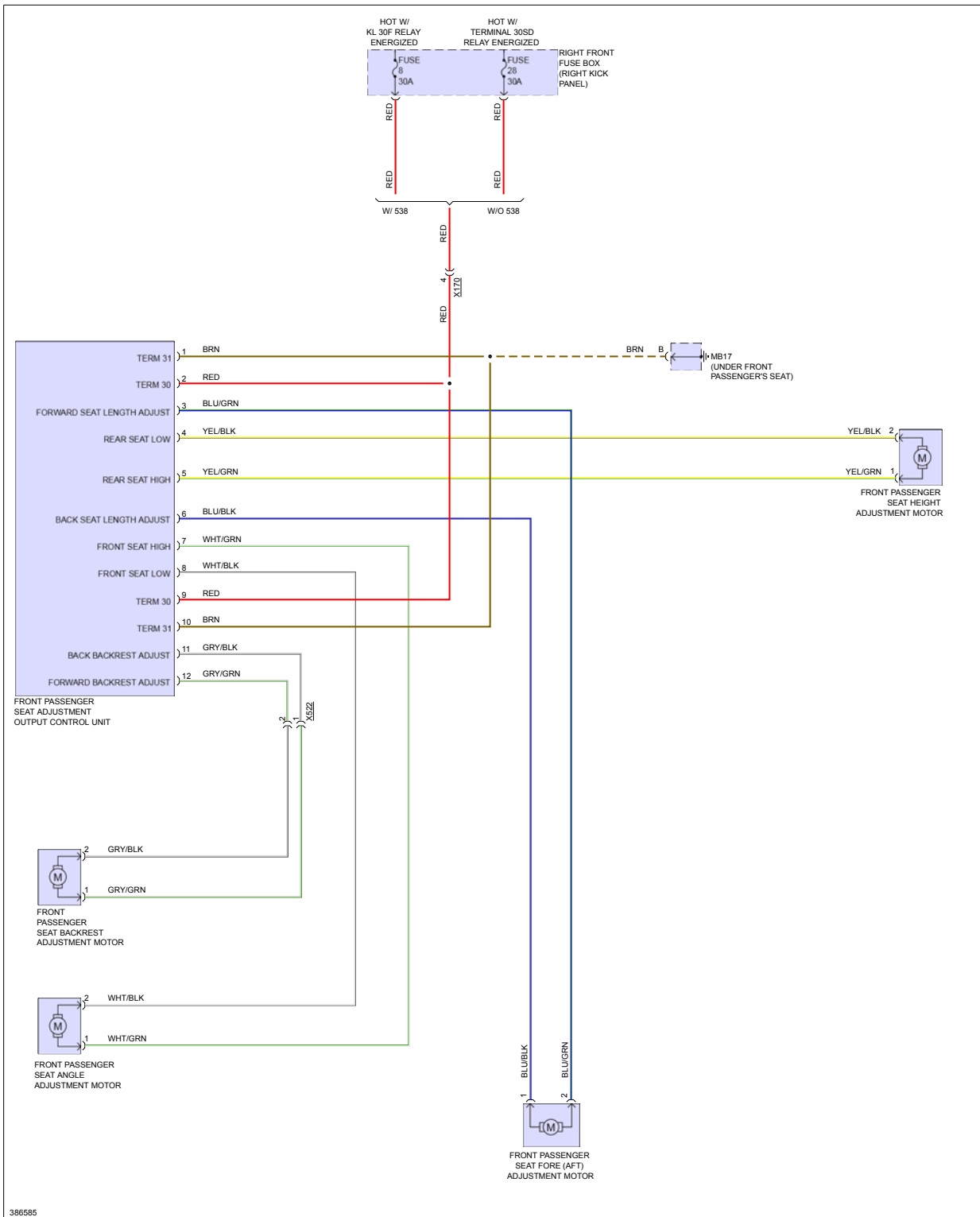

Fig 4: Rear Heated Seats Circuit

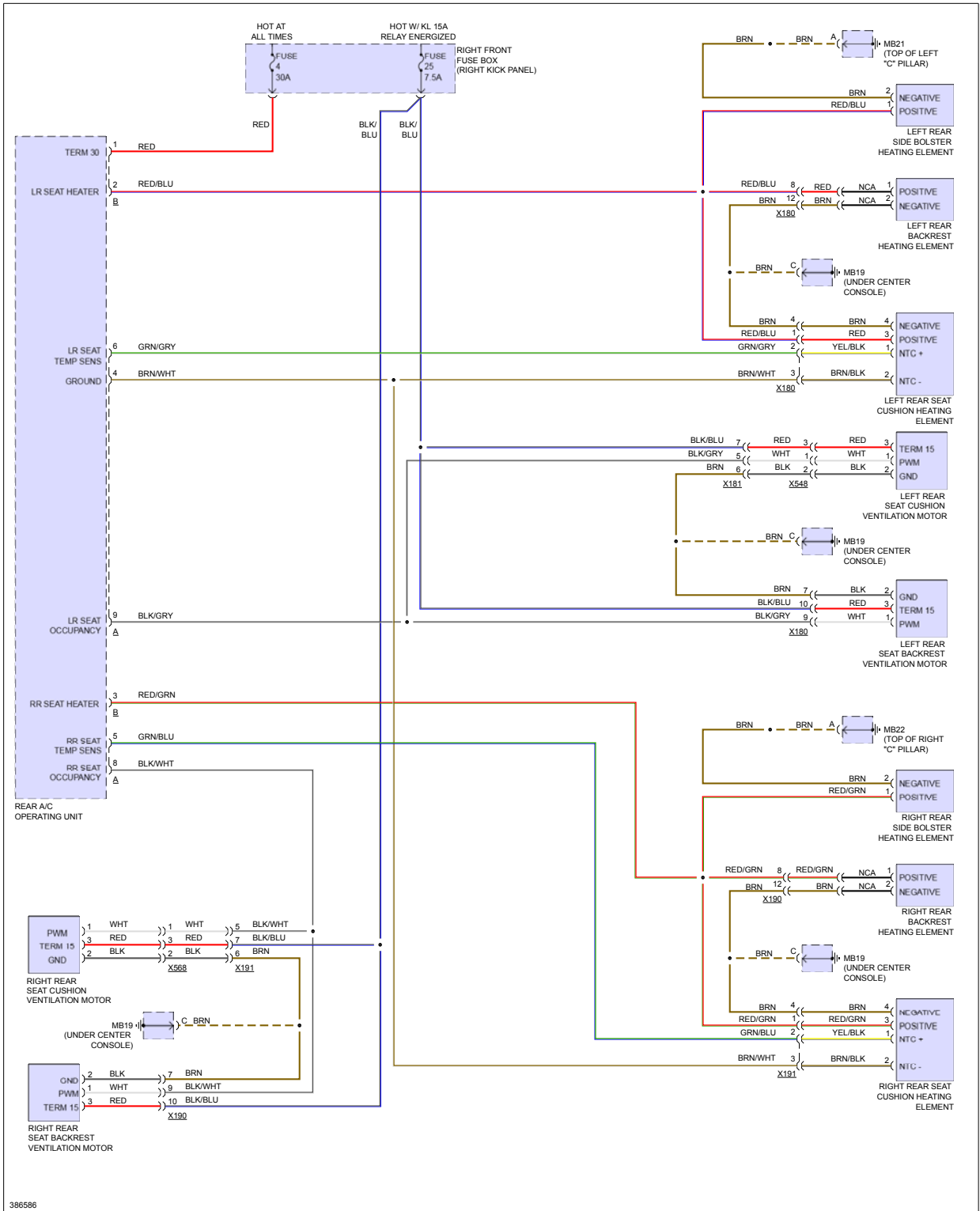
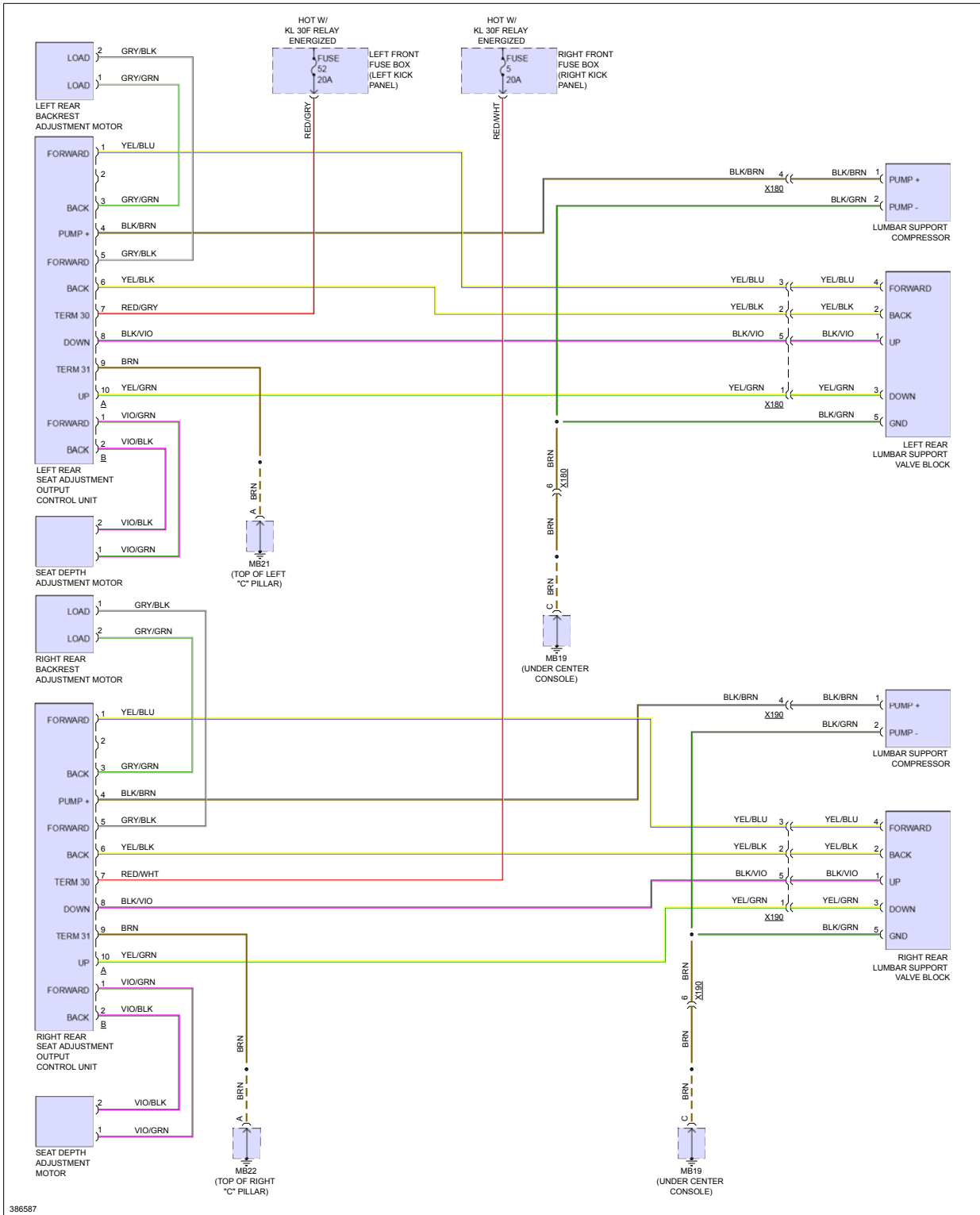

Fig 5: Rear Power Seat Circuit



# POWER TOP/SUNROOF

Fig 1: Power Top/Sunroof Circuit

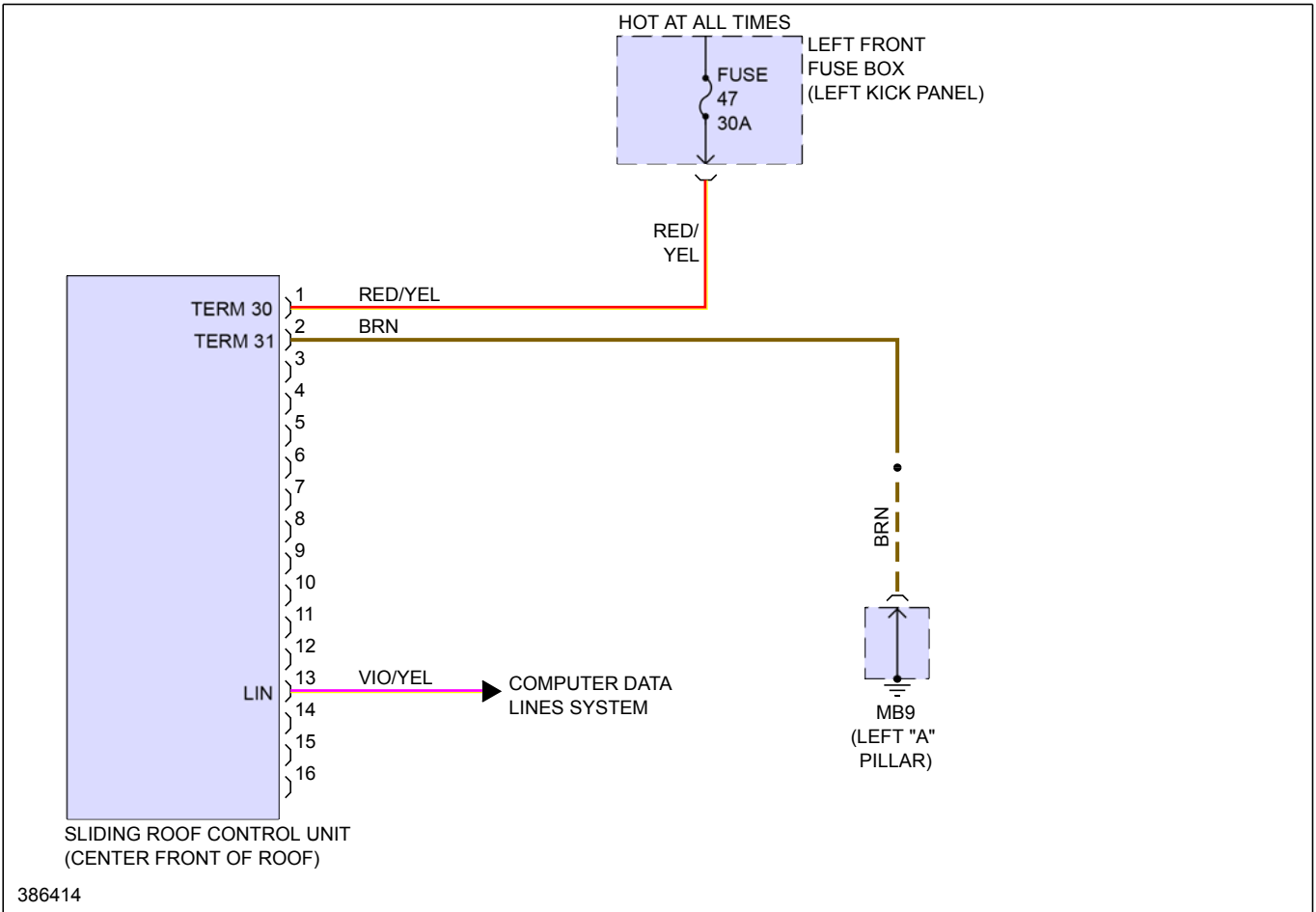
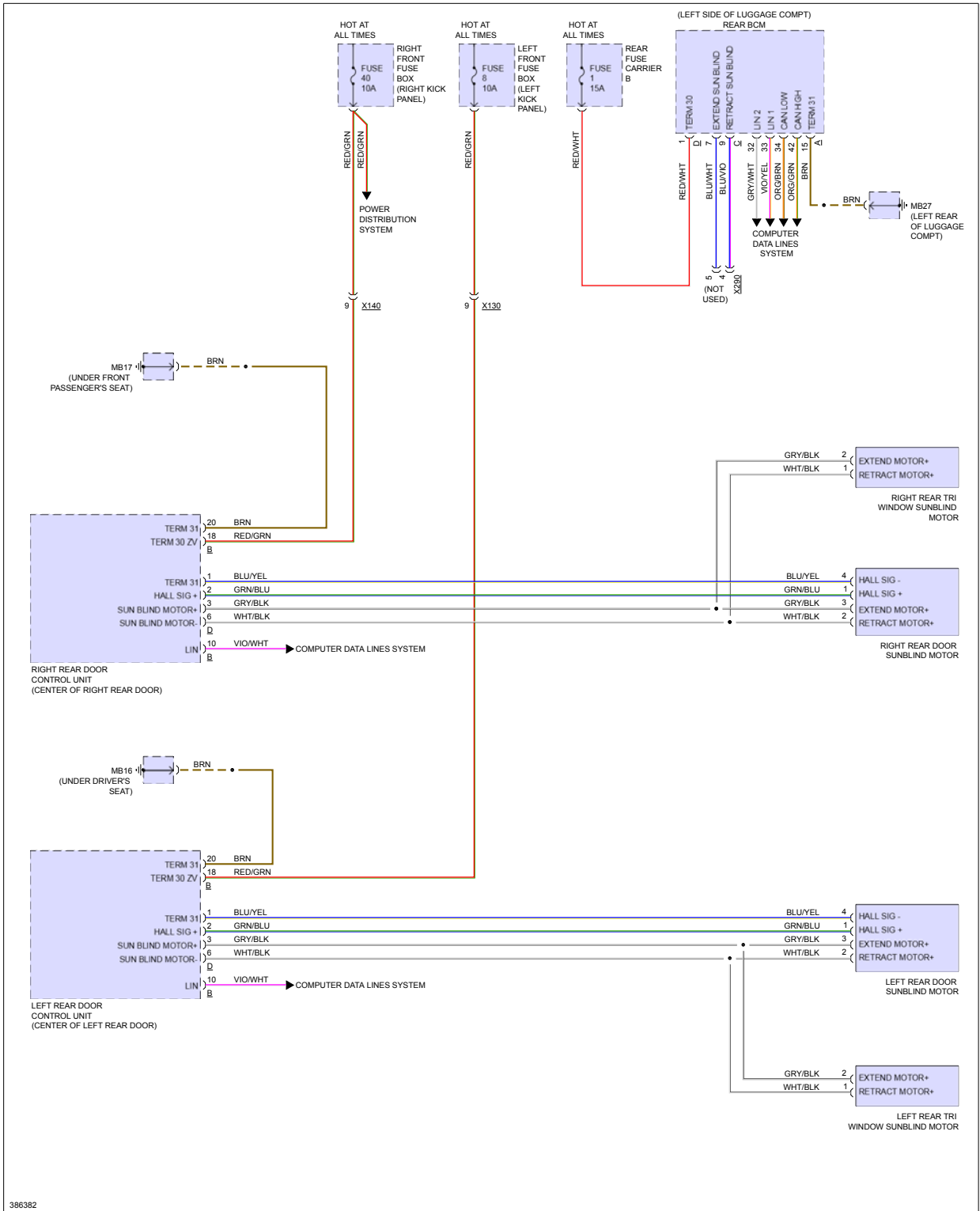





Fig 2: Rear Window Sun Shade Circuit



# RADIO

Fig 1: Base Radio Circuit, W/ Amplifier (1 of 2)

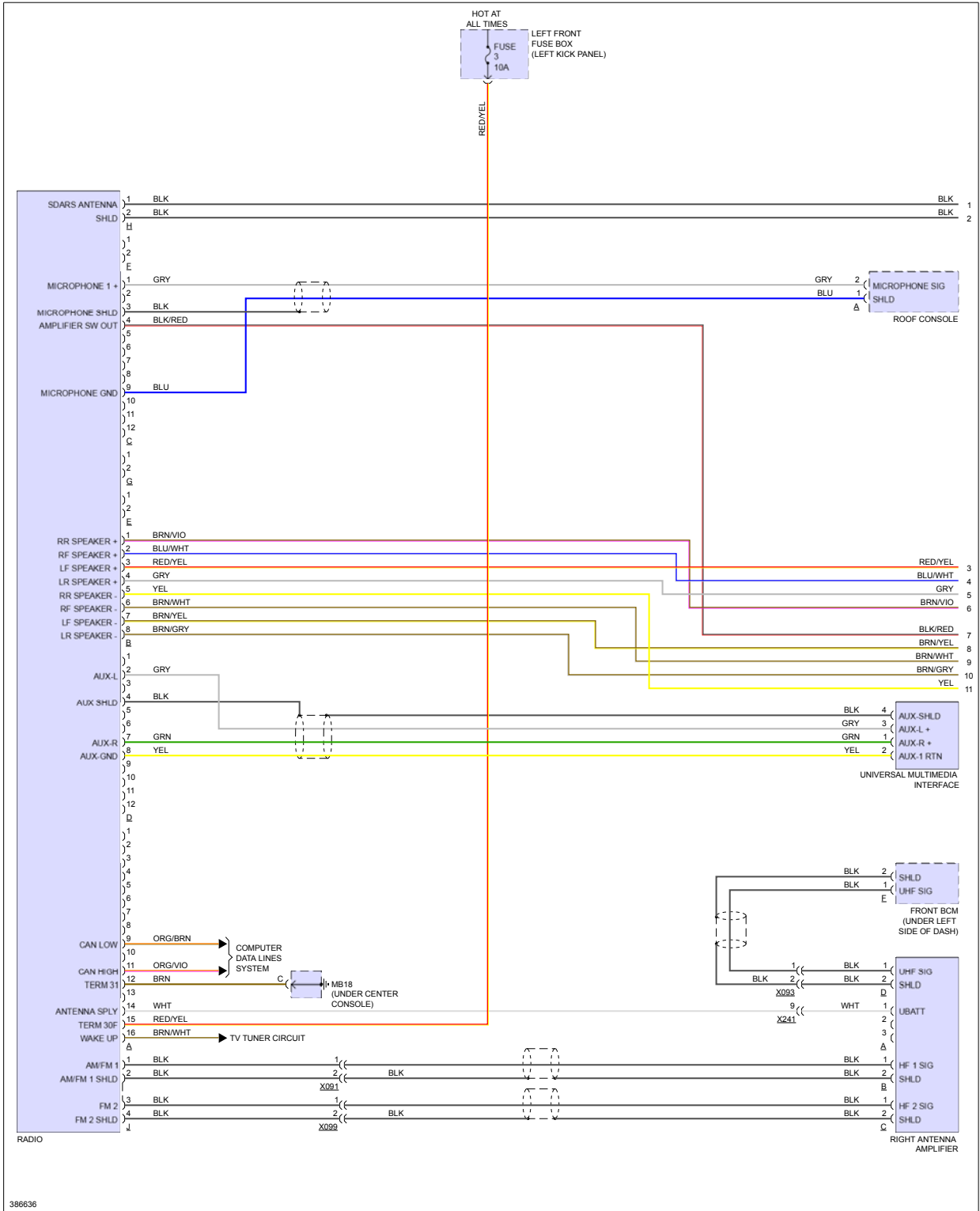

Fig 2: Base Radio Circuit, W/ Amplifier (2 of 2)

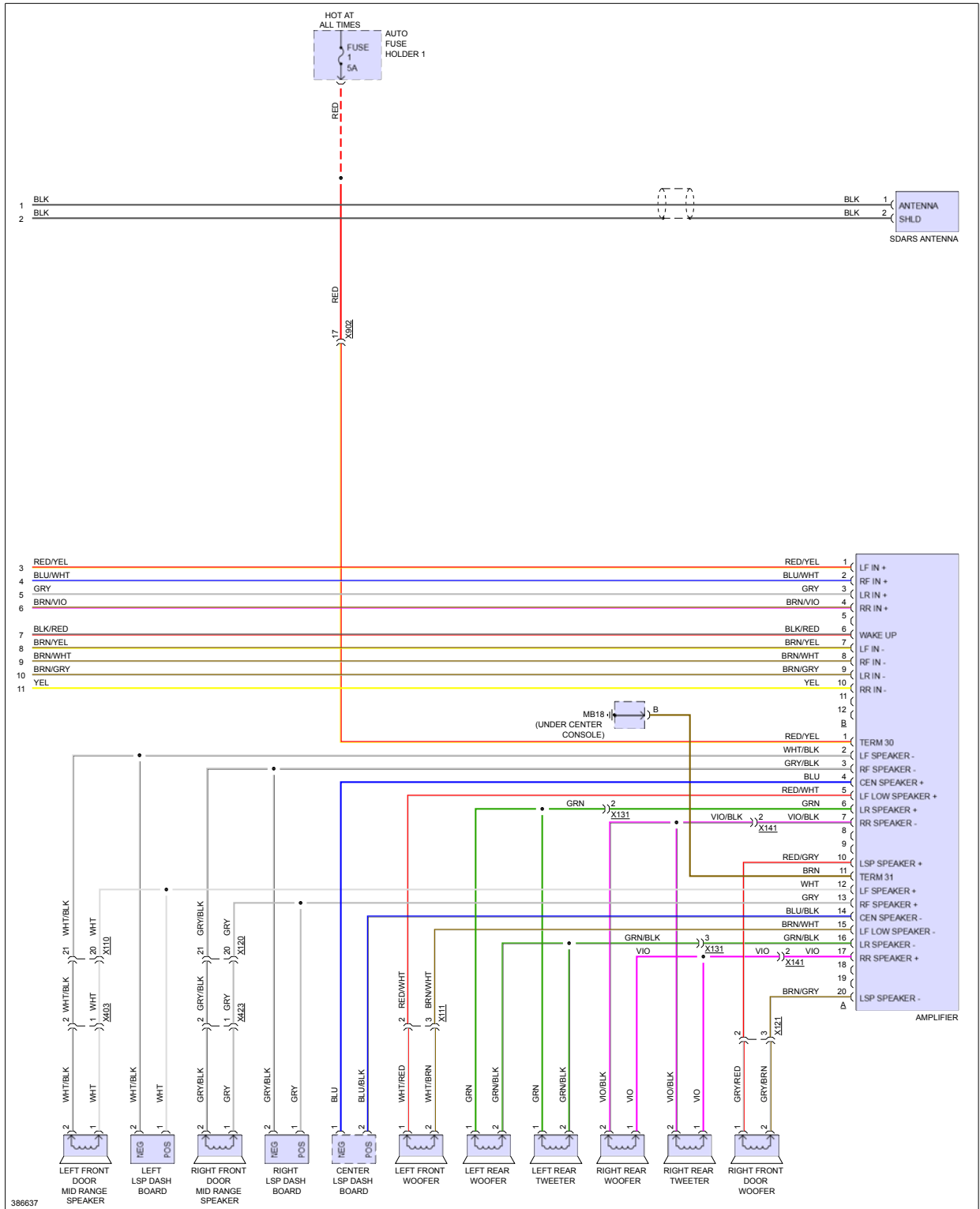

Fig 3: Base Radio Circuit, W/O Amplifier

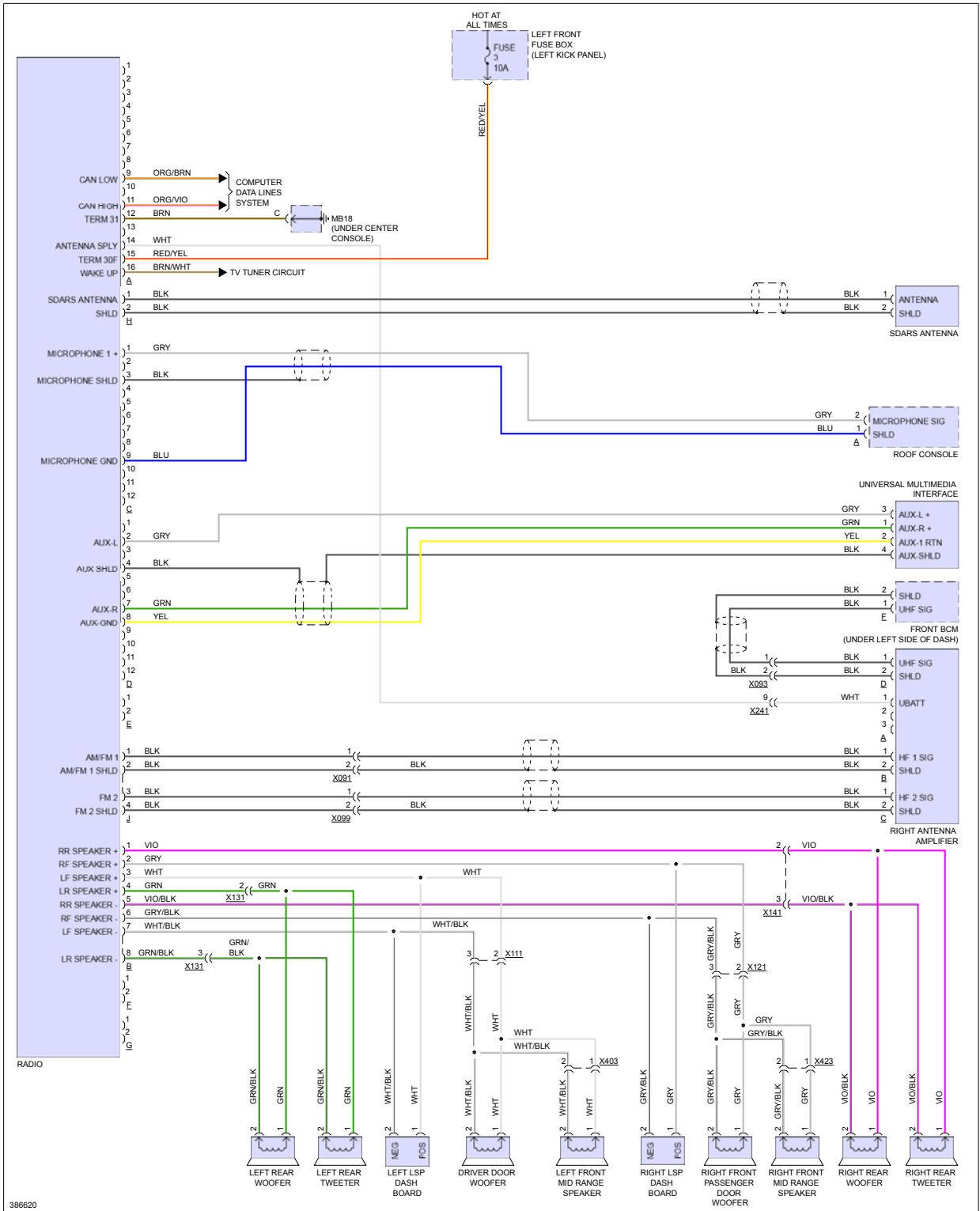

Fig 4: Optical WaveGuide Circuit

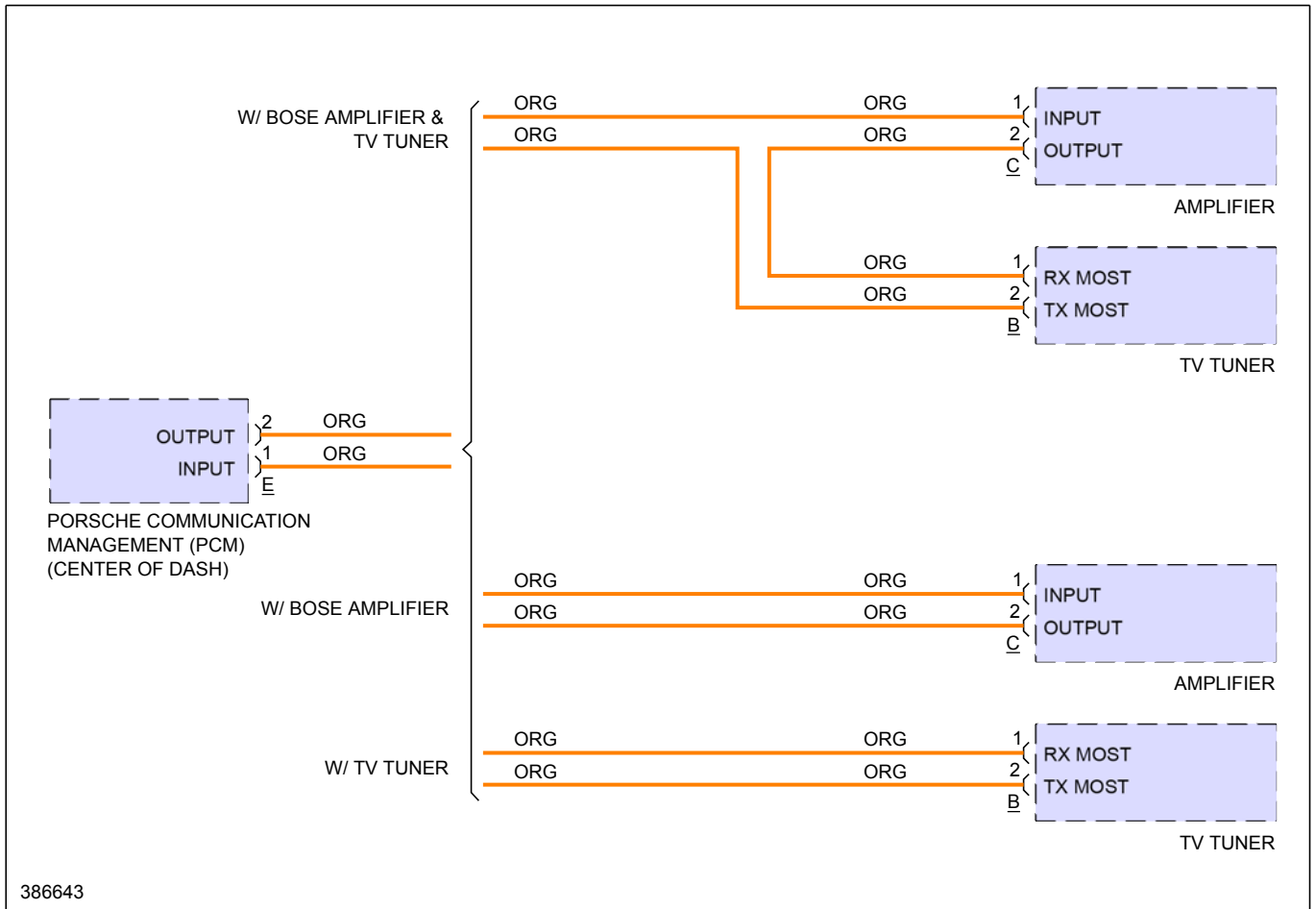

Fig 5: Premium Radio Circuit, W/ ASK (1 of 2)

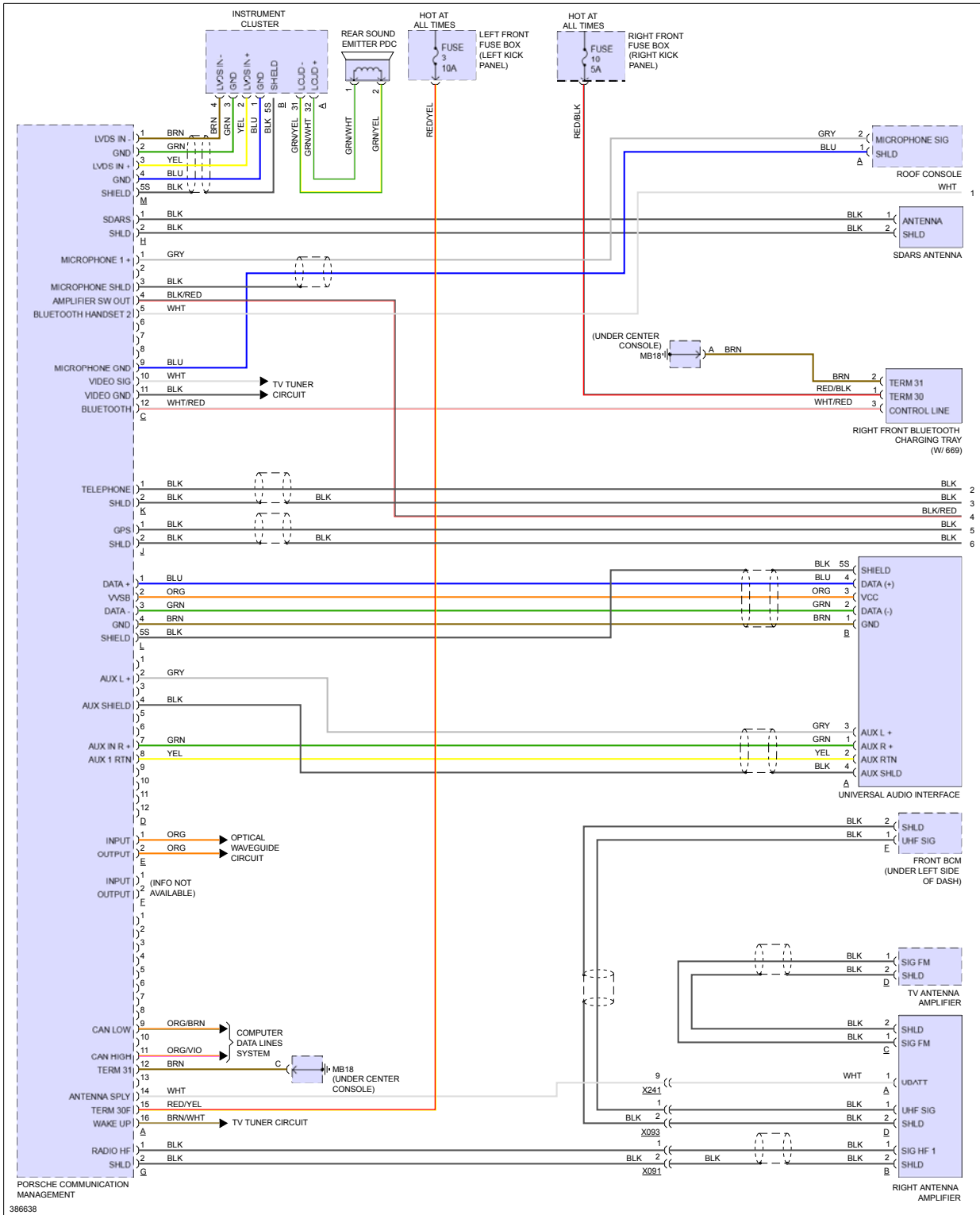

Fig 6: Premium Radio Circuit, W/ ASK (2 of 2)

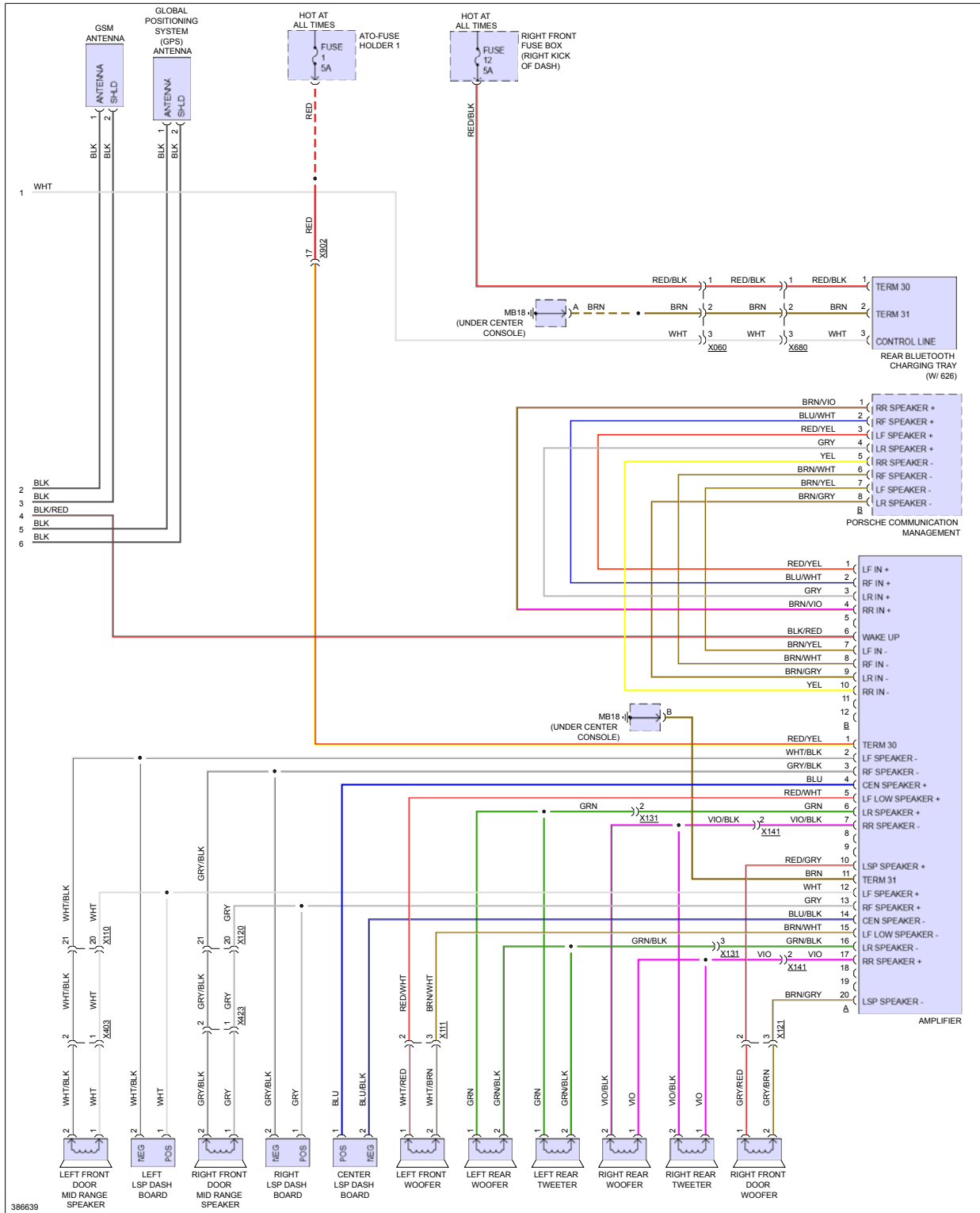

Fig 7: Premium Radio Circuit, W/ Bose (1 of 2)

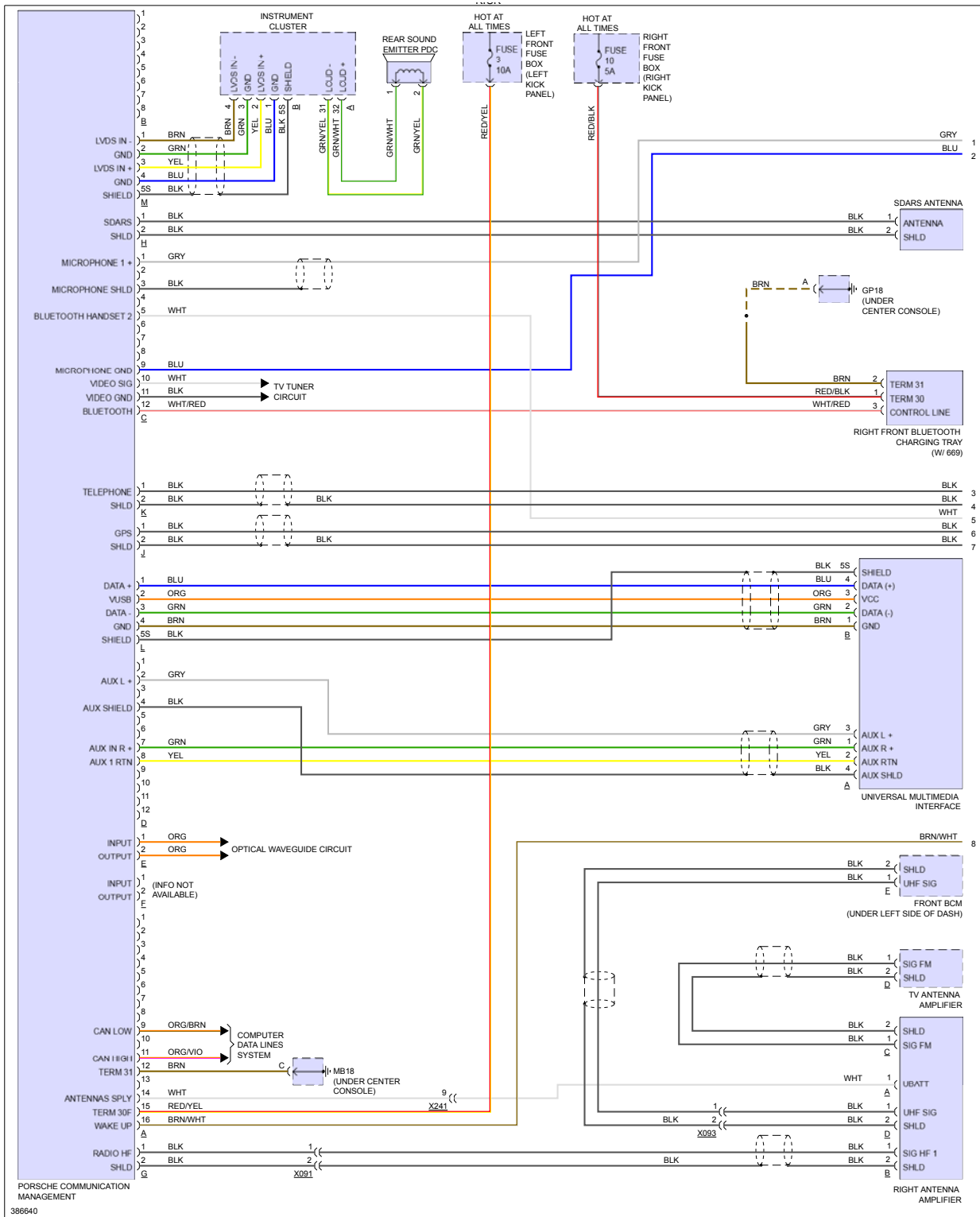



Fig 8: Premium Radio Circuit, W/ Bose (2 of 2)

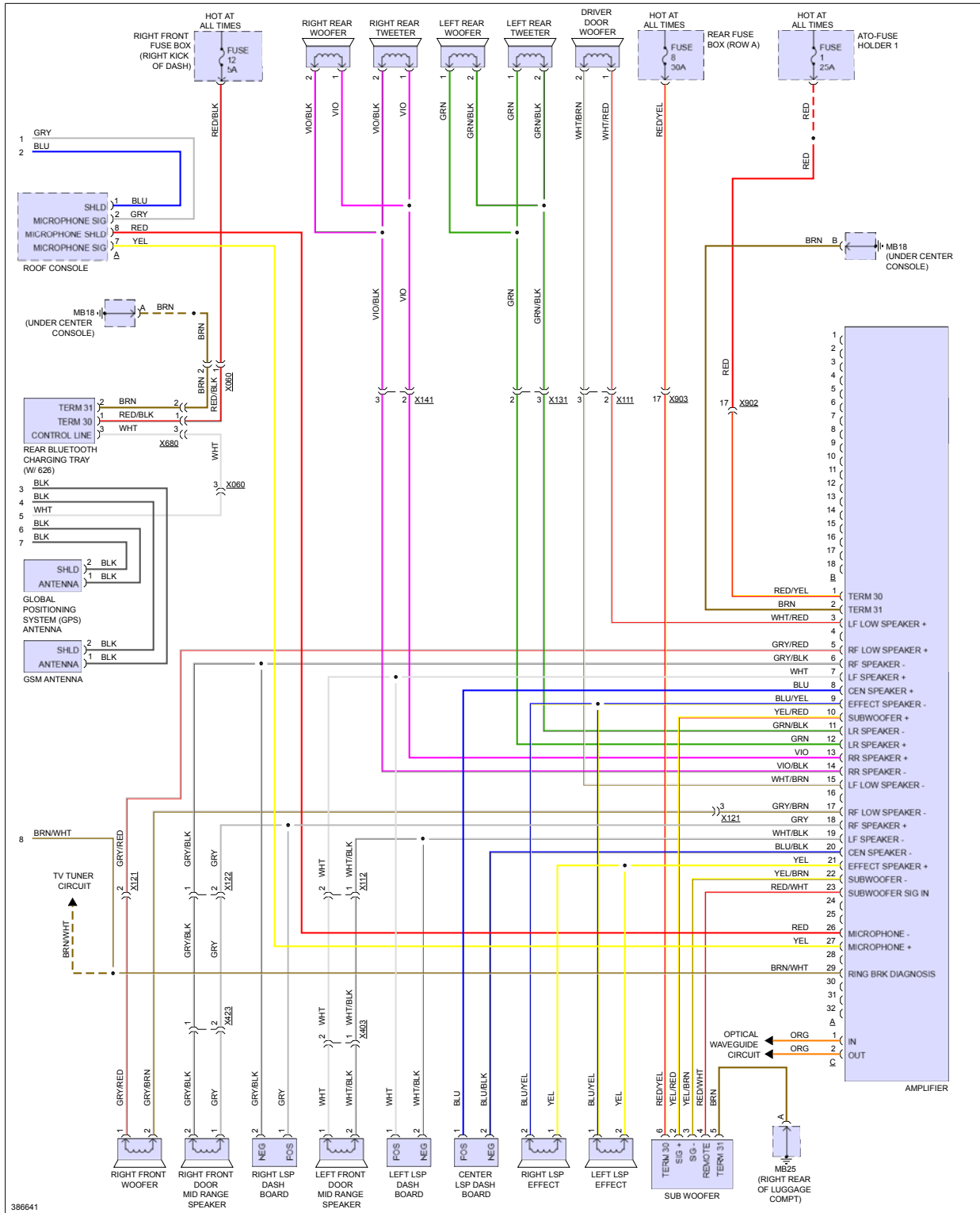

Fig 9: Premium Radio Circuit, W/ Burmester (1 of 3)

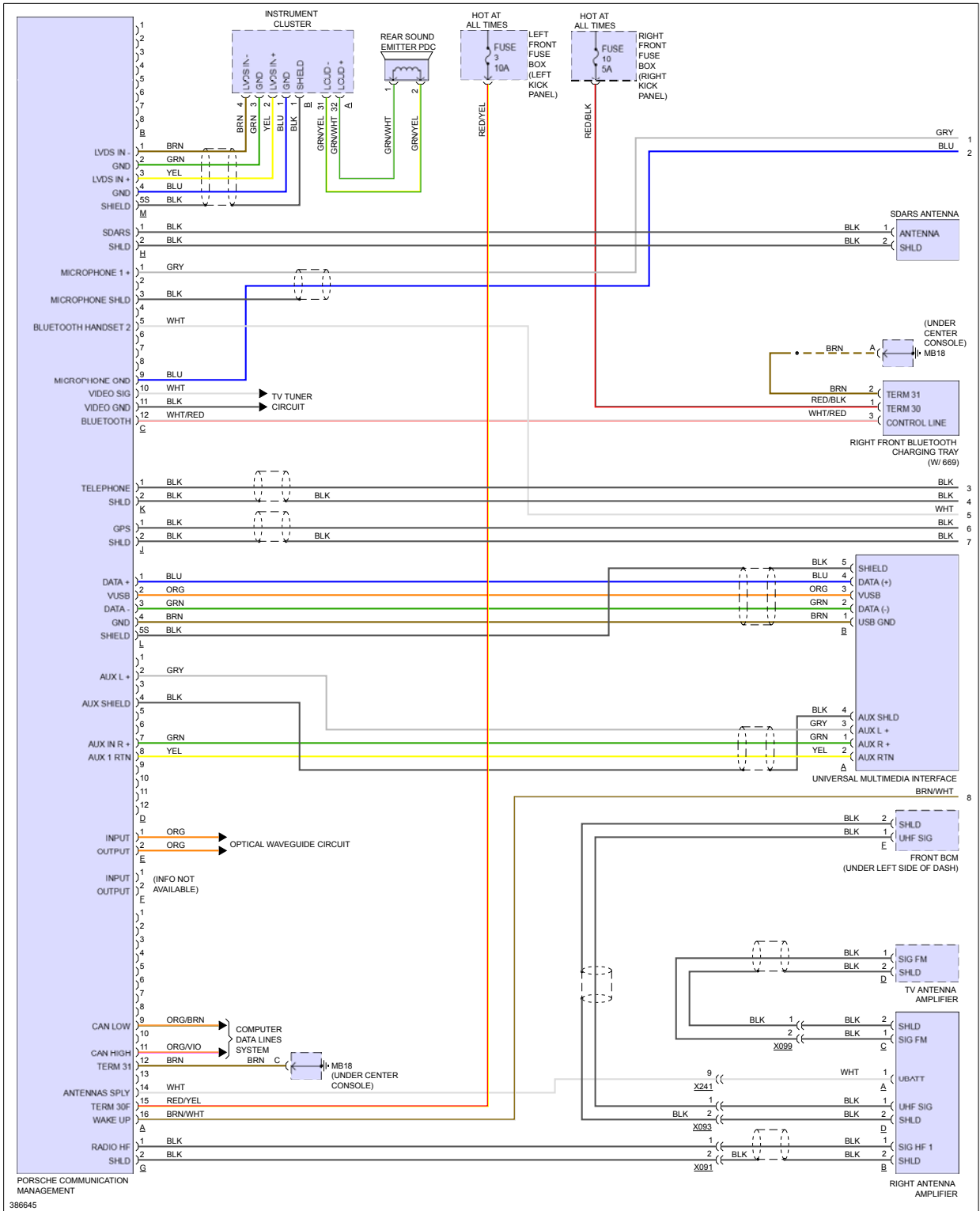

Fig 10: Premium Radio Circuit, W/ Burmester (2 of 3)

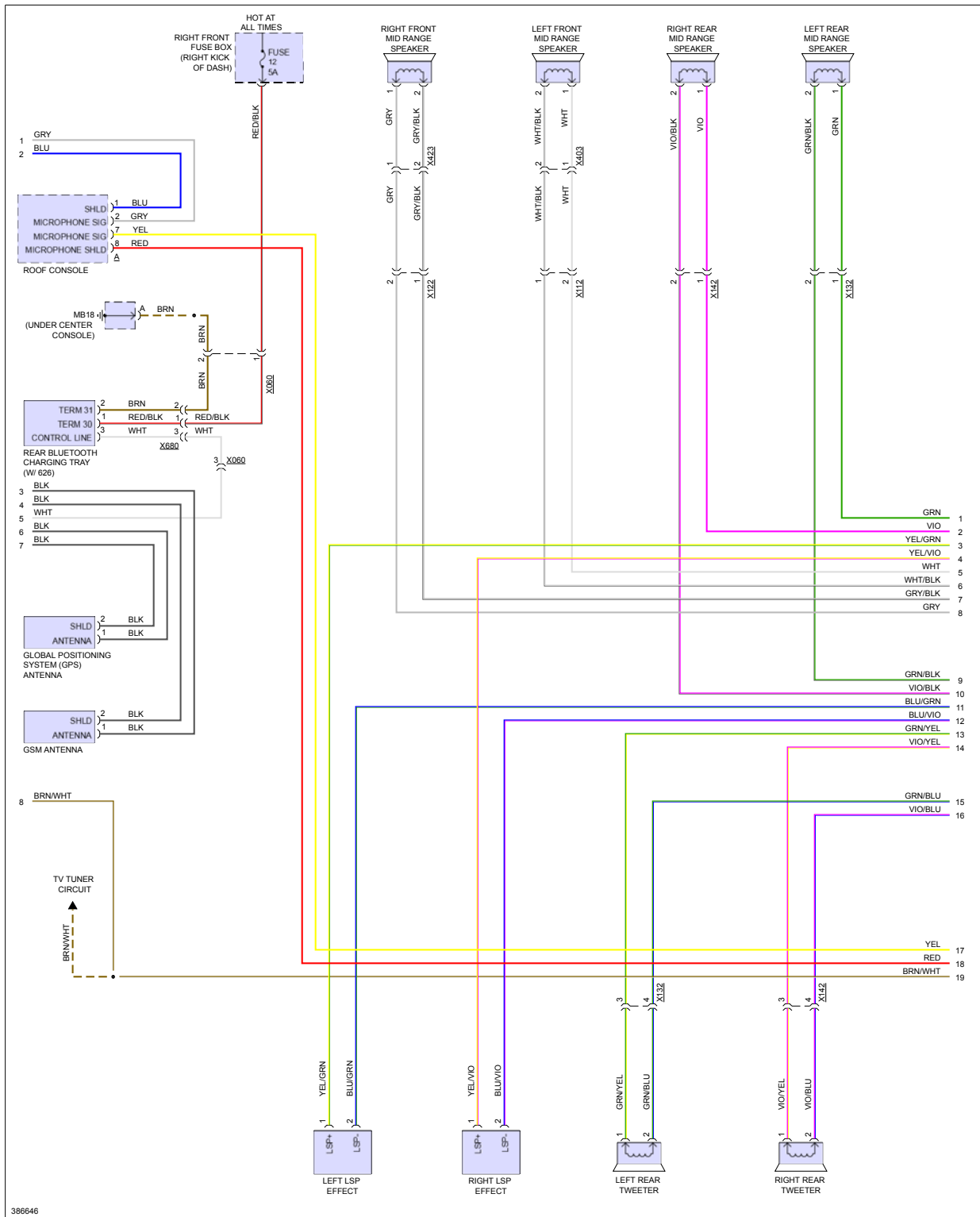

Fig 11: Premium Radio Circuit, W/ Burmester (3 of 3)

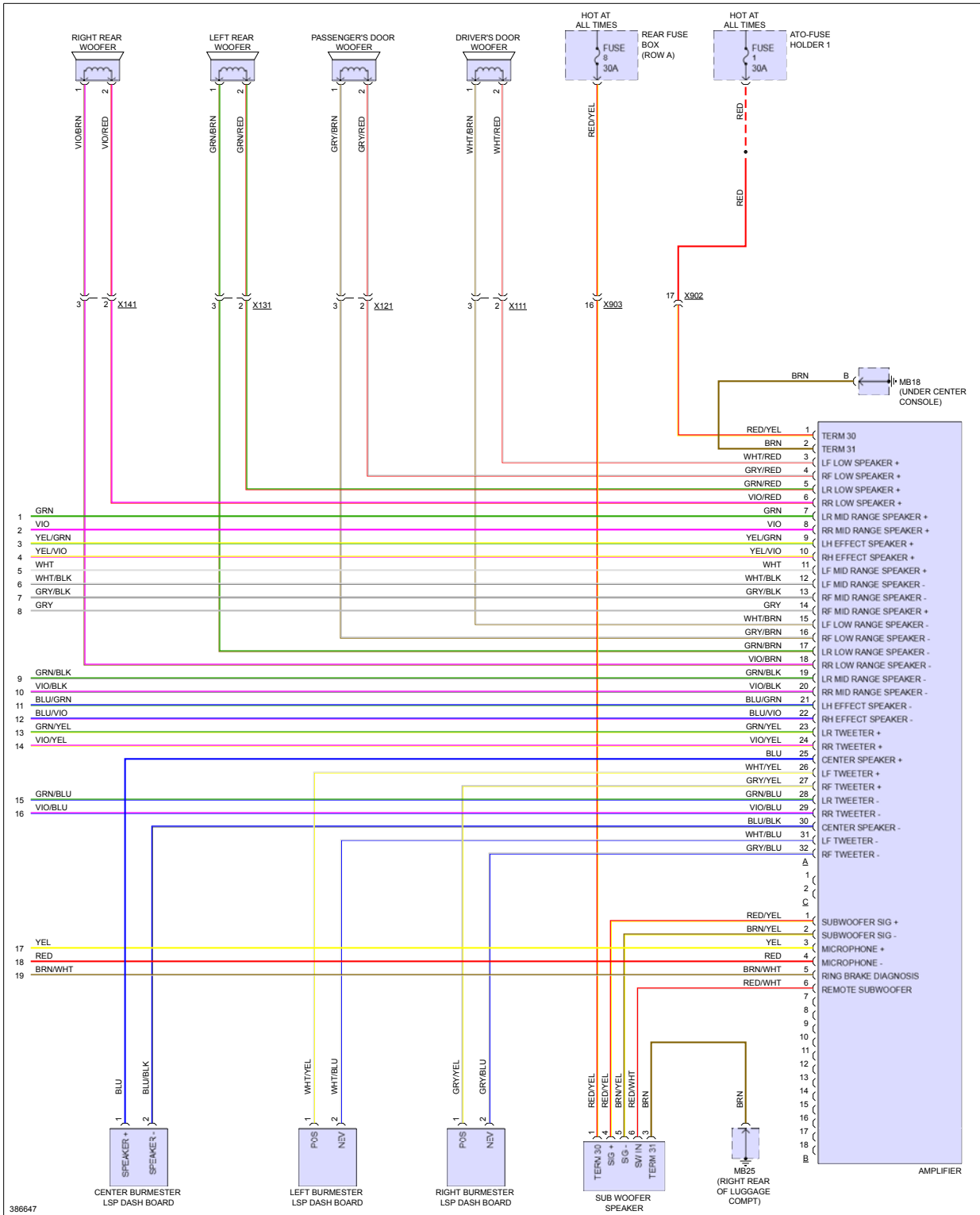

Fig 12: Rear Seat Entertainment Circuit

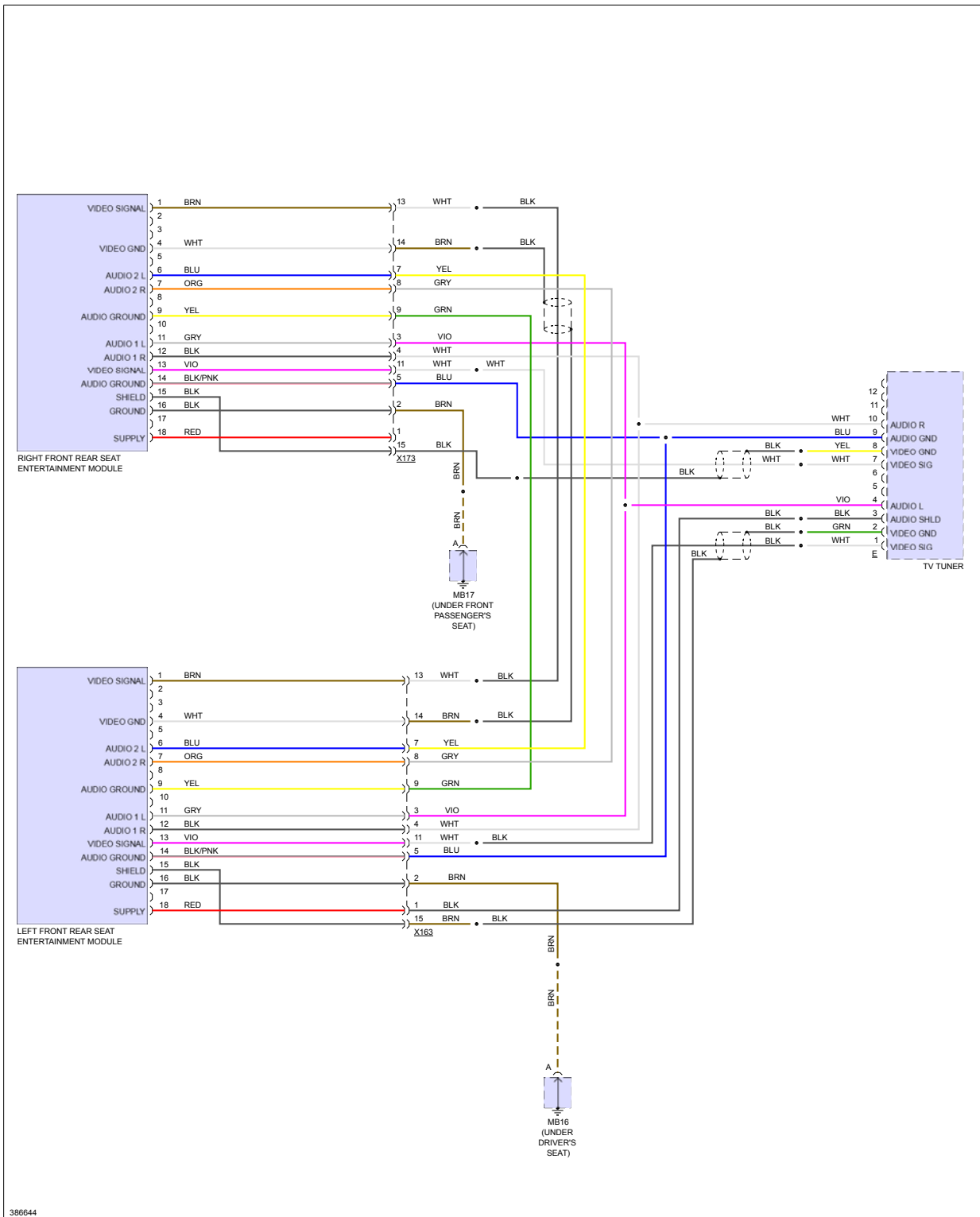
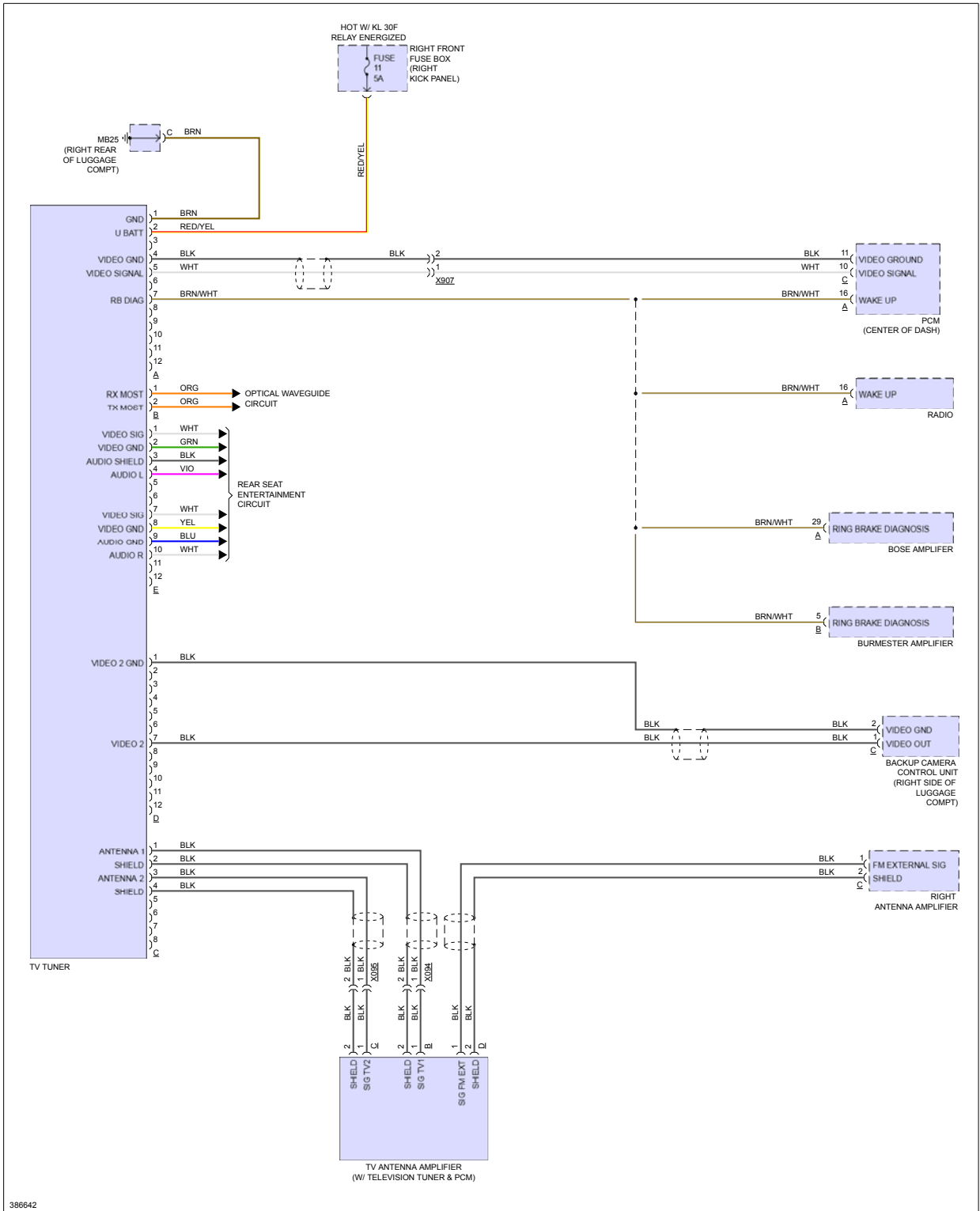

Fig 13: TV Tuner Circuit



# SHIFT INTERLOCK

Fig 1: Electronic Parking Brake Circuit

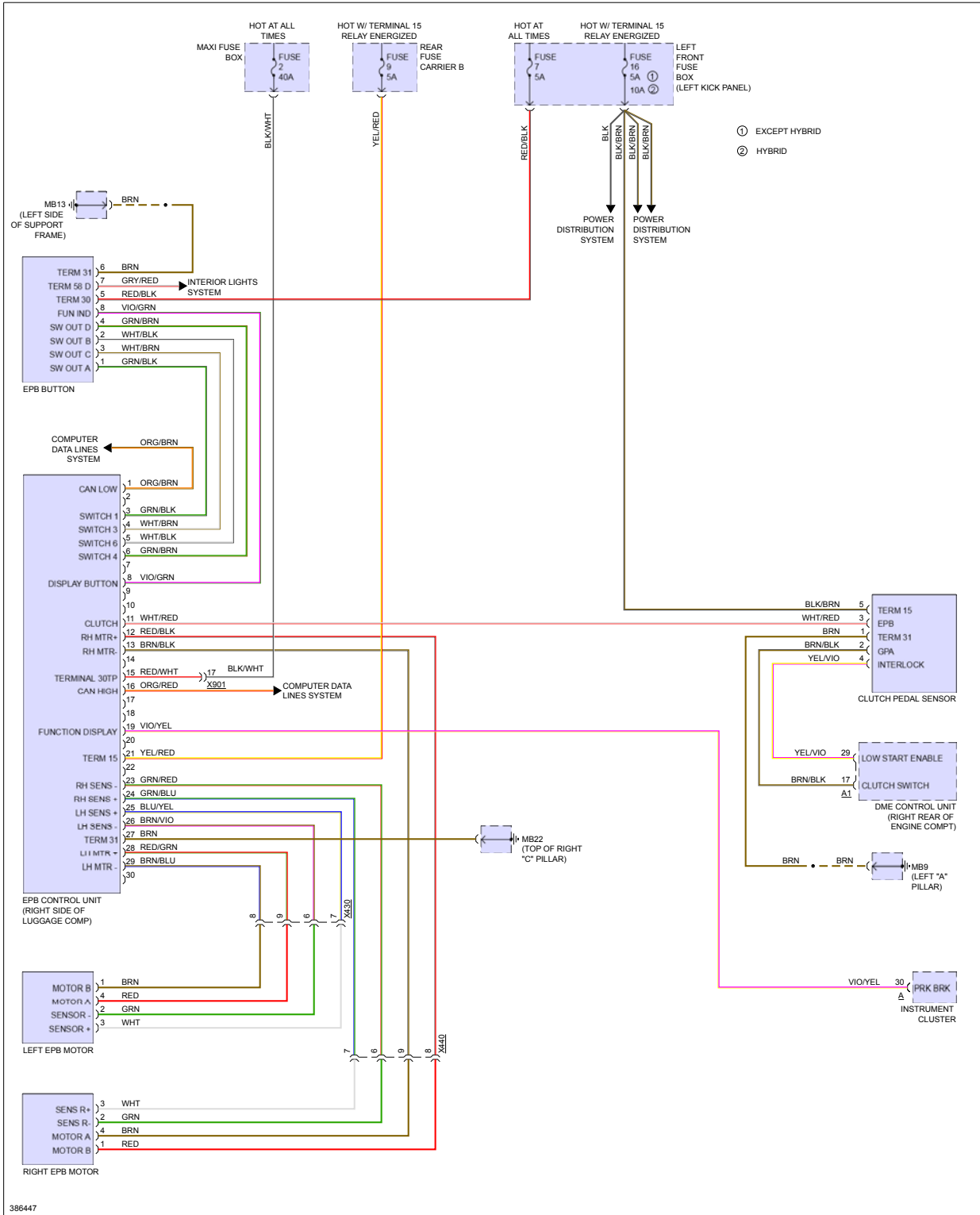
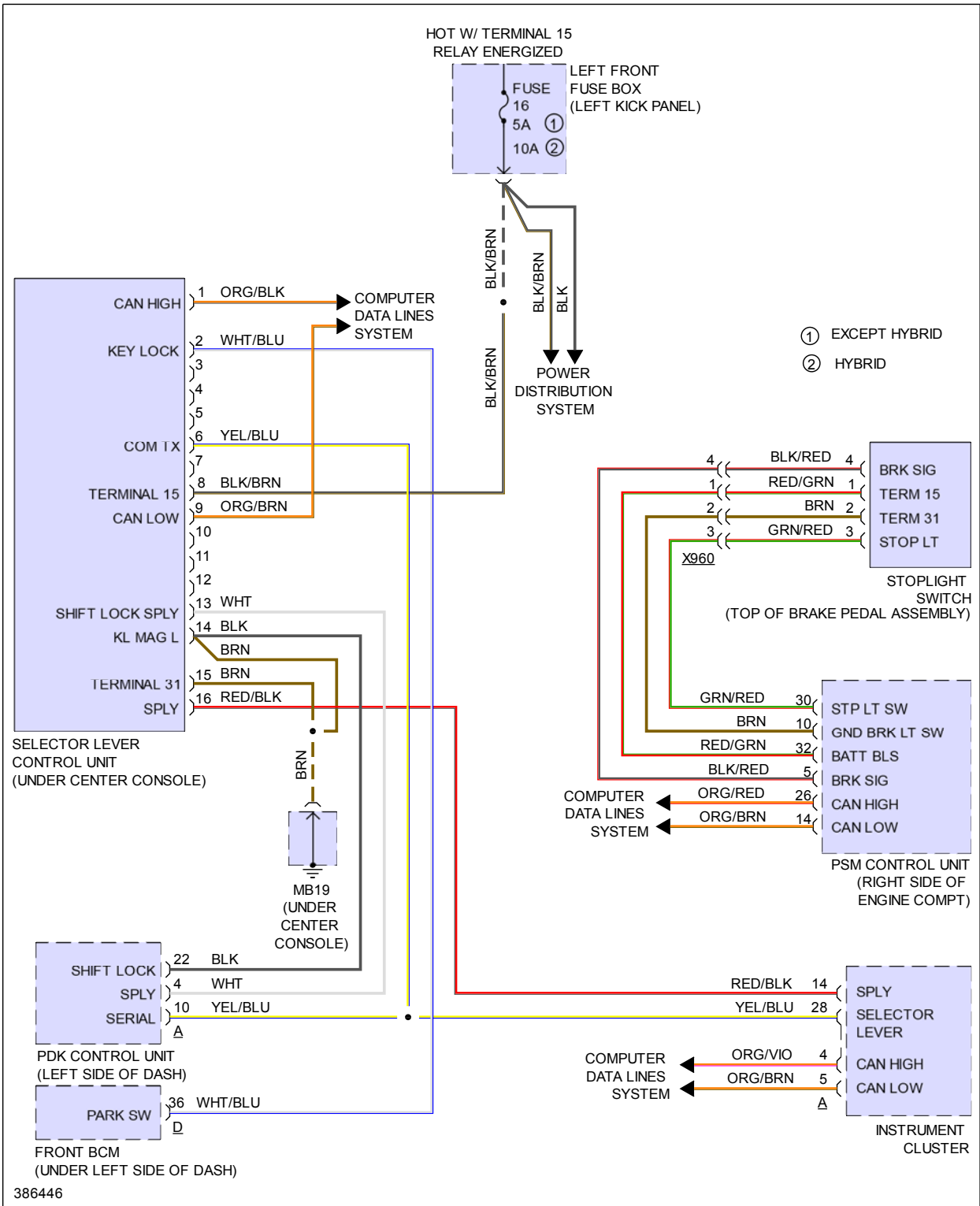

Fig 2: Shift Interlock Circuit





# STARTING/CHARGING

Fig 1: Charging Circuit

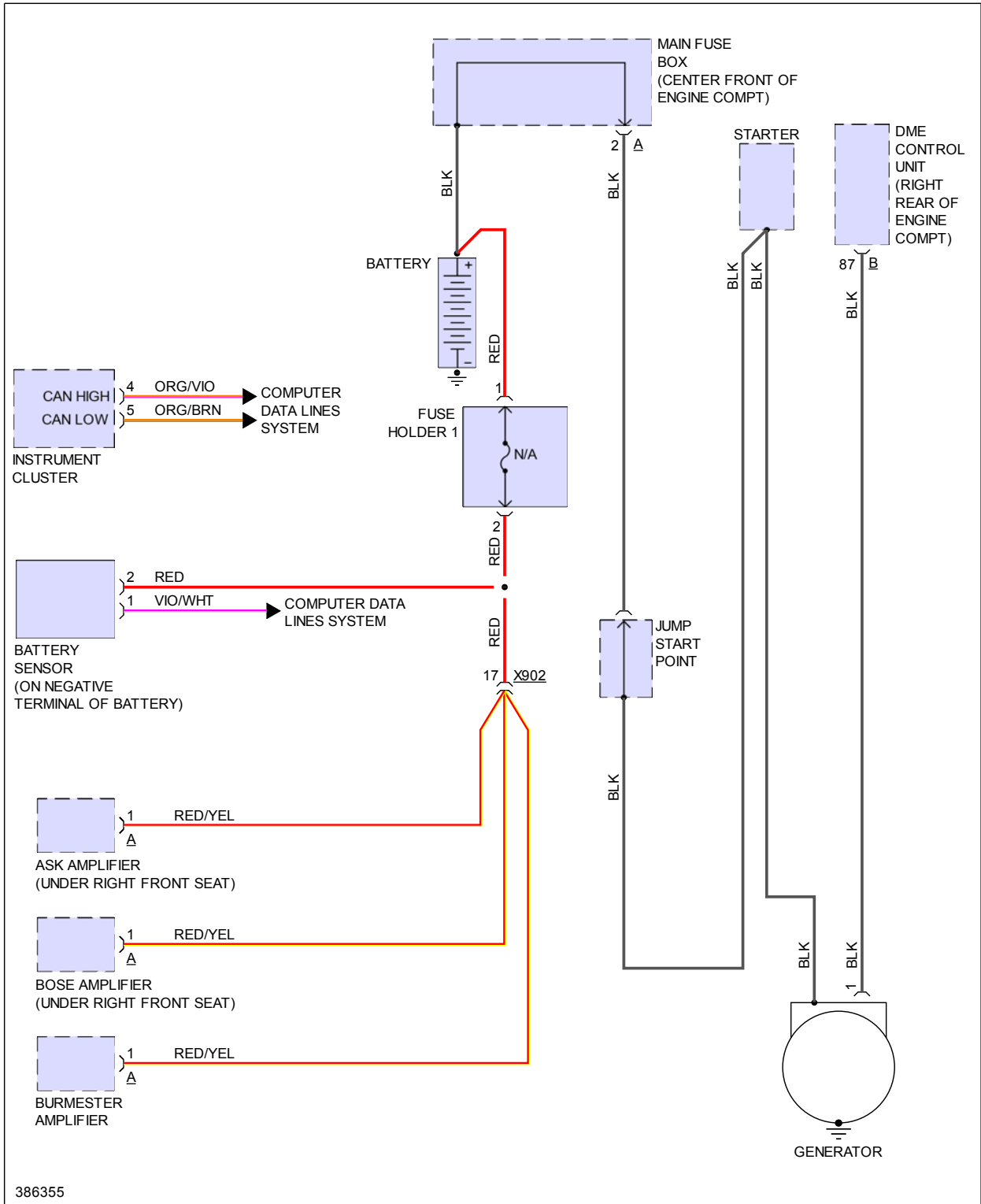
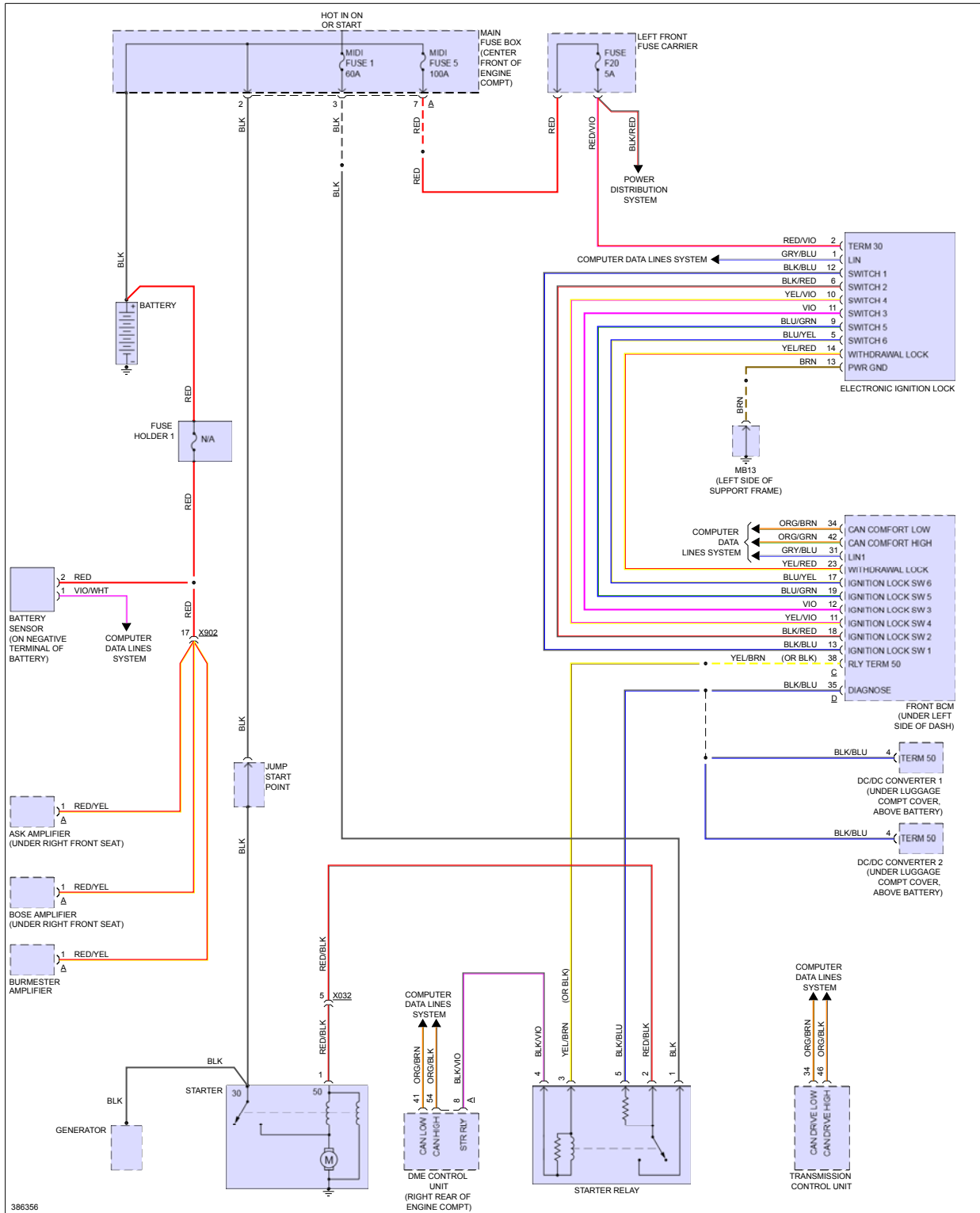

Fig 2: Starting Circuit



# SUPPLEMENTAL RESTRAINTS

Fig 1: Supplemental Restraints Circuit (1 of 3)

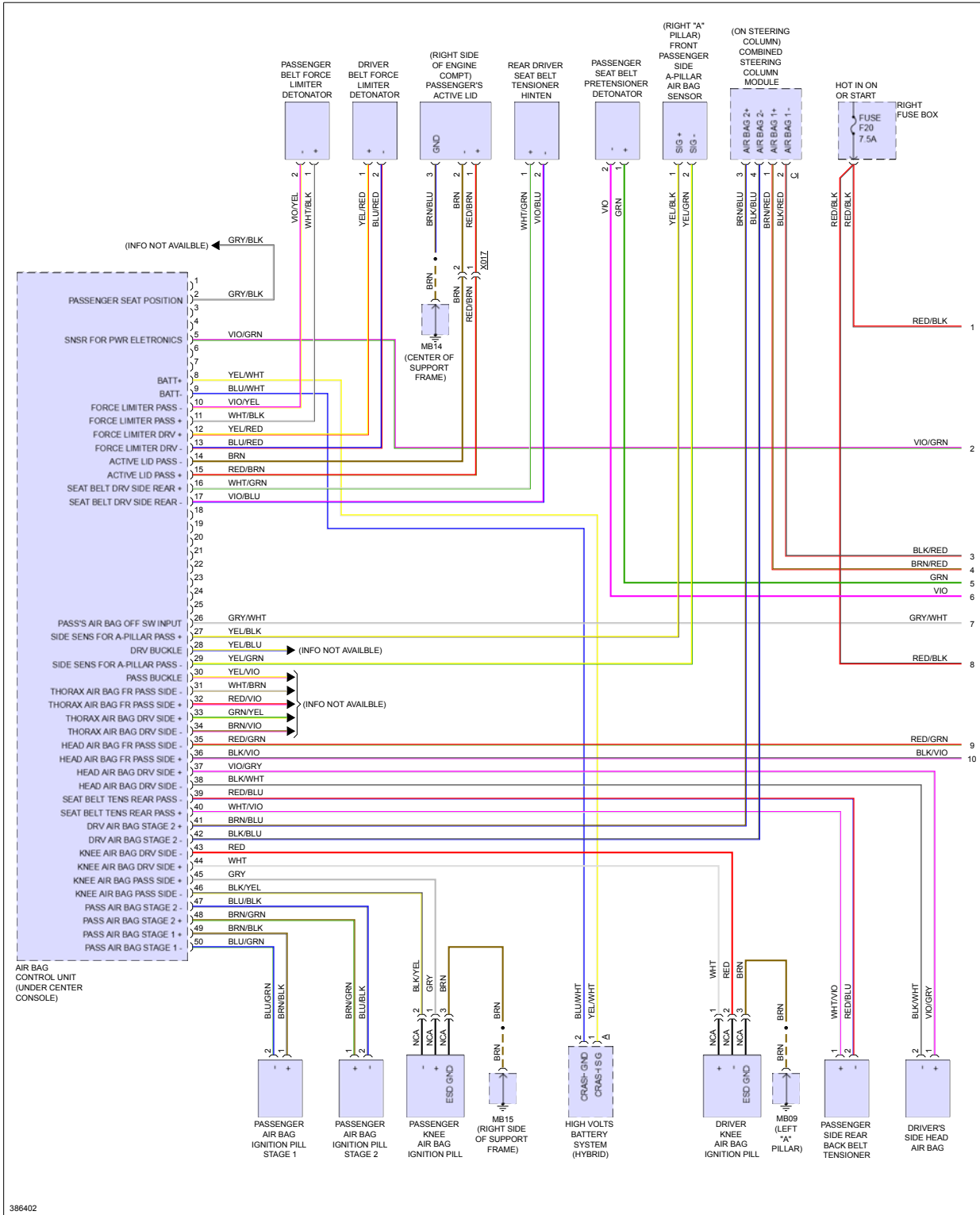

Fig 2: Supplemental Restraints Circuit (2 of 3)

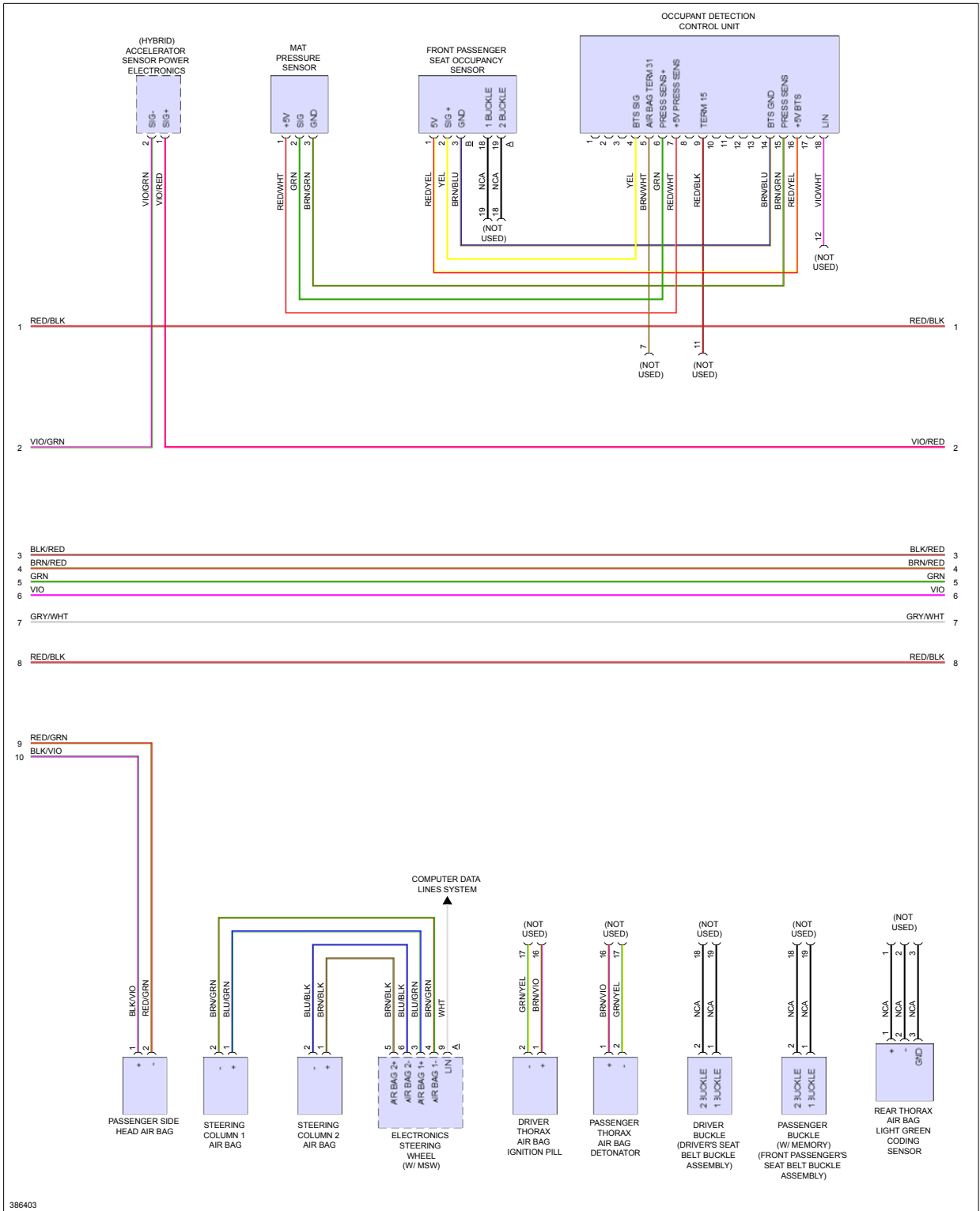
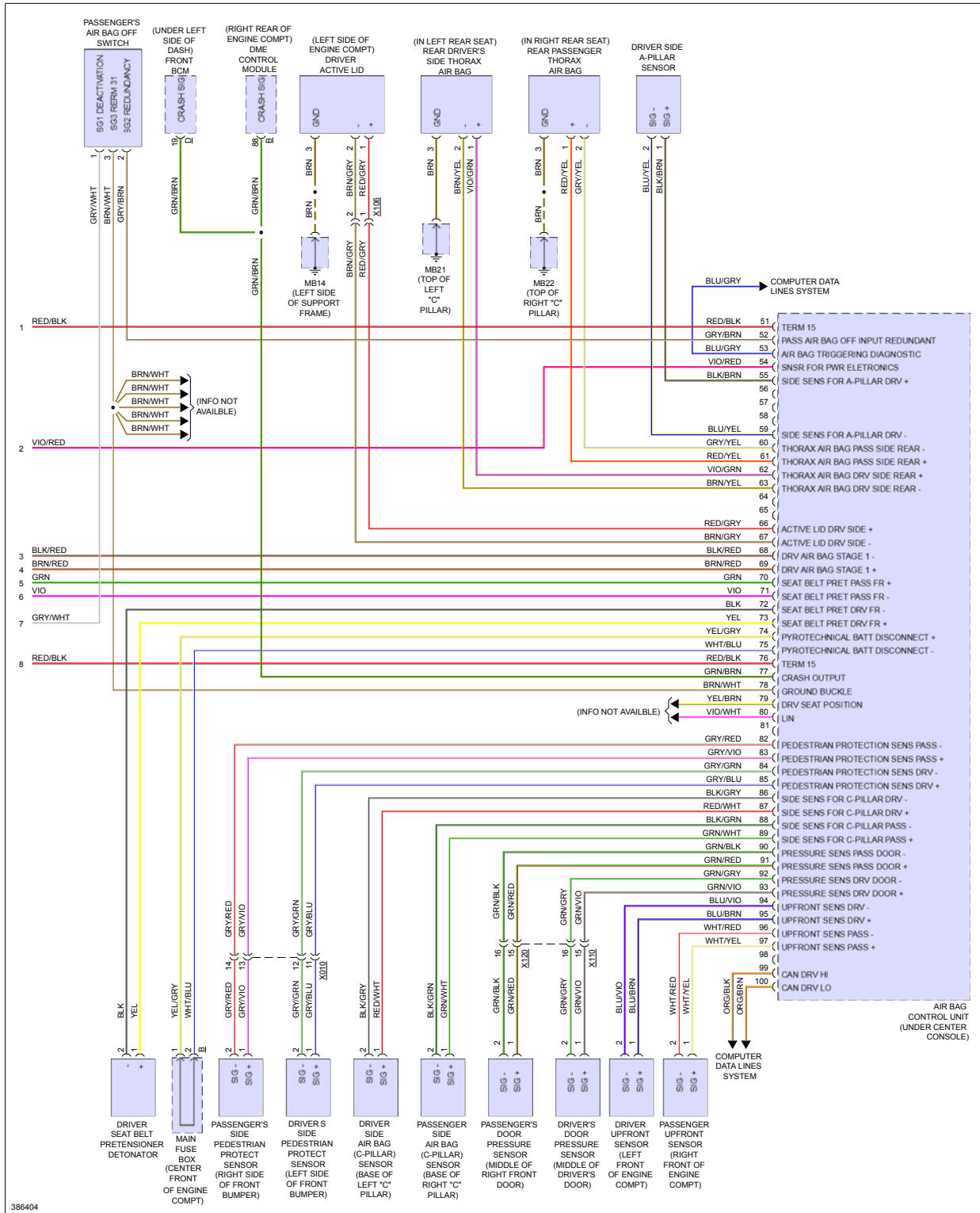

Fig 3: Supplemental Restraints Circuit (3 of 3)



# TRANSMISSION

Fig 1: A/T Circuit, Except Hybrid

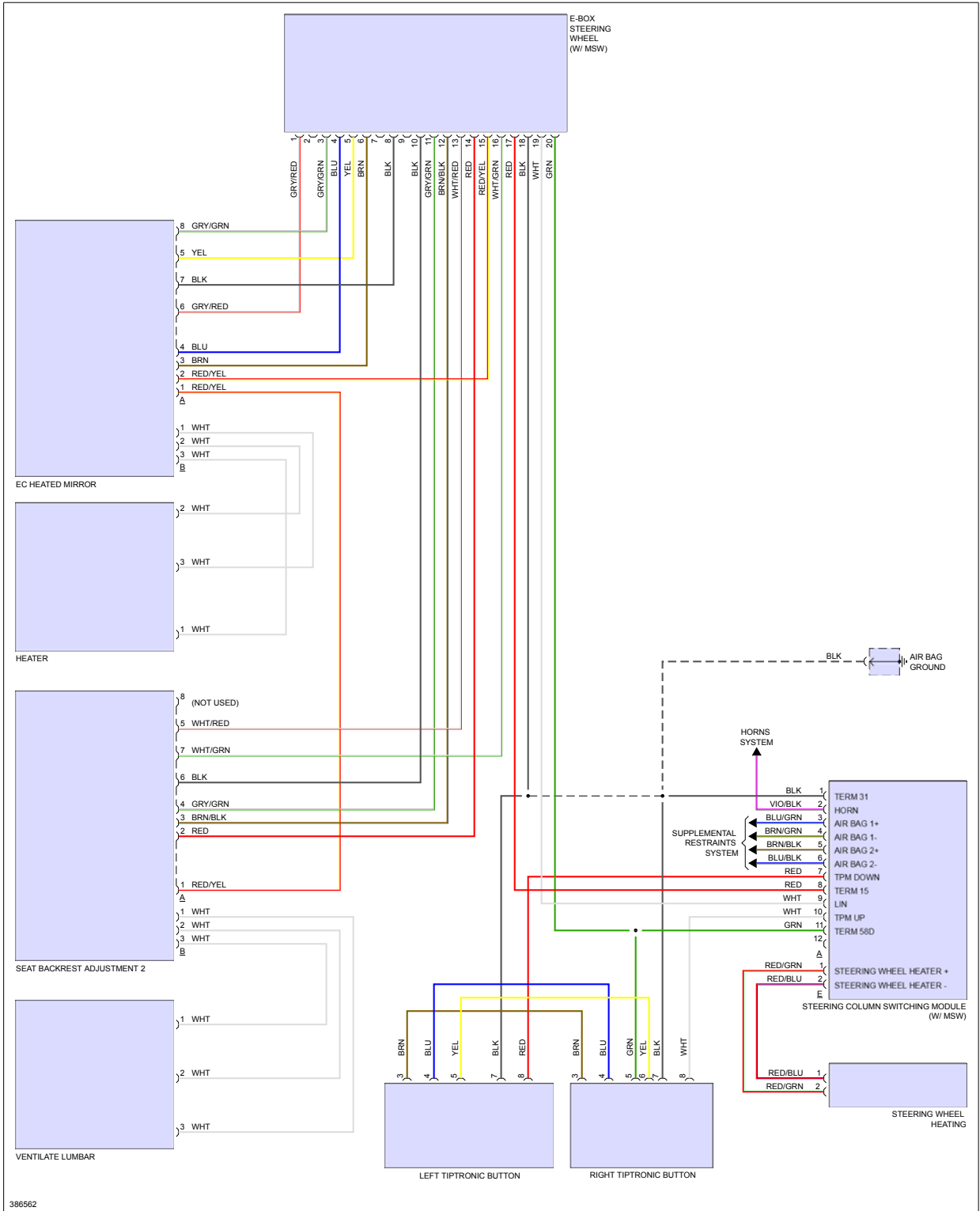

Fig 2: A/T Circuit, Hybrid

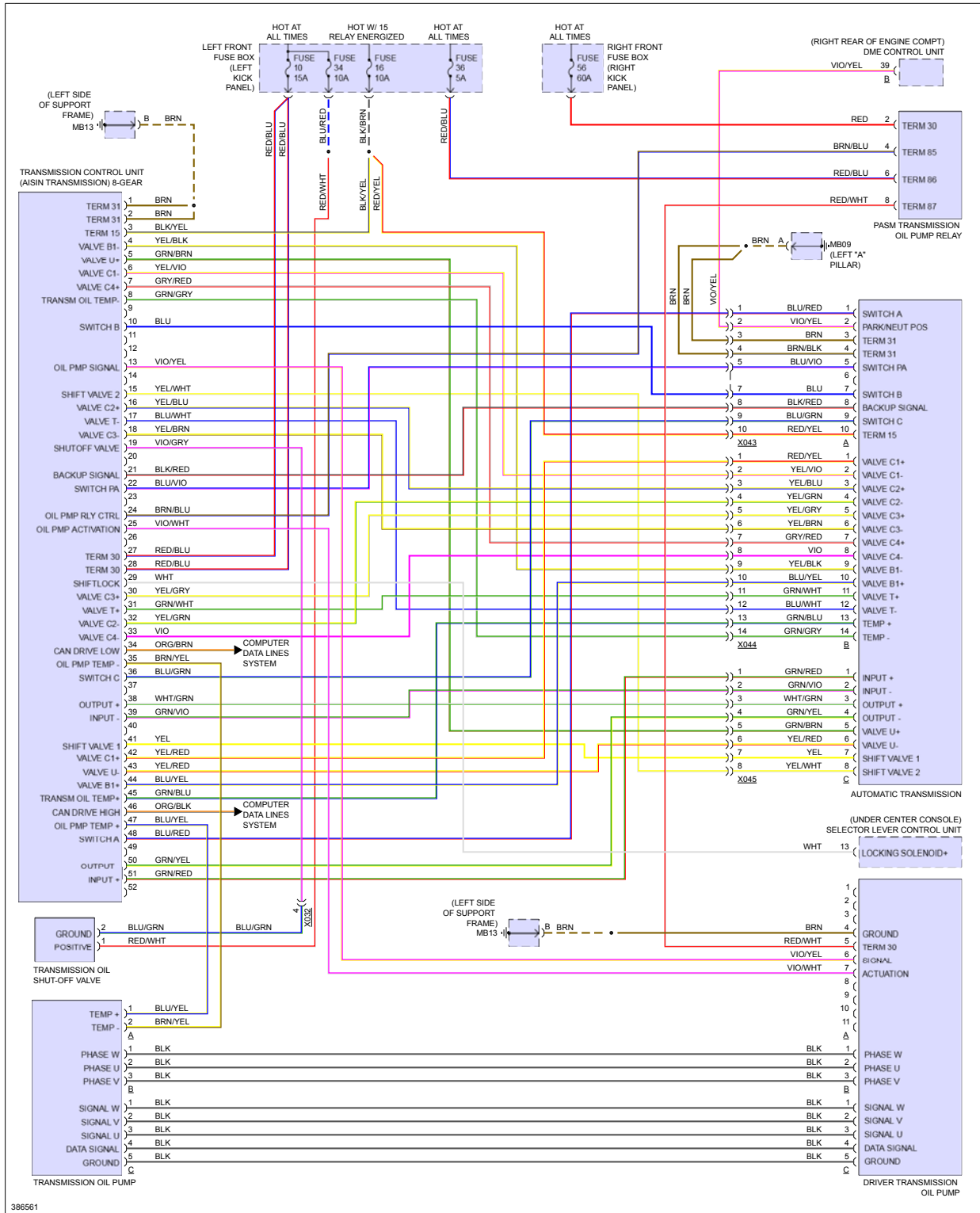

Fig 3: PDK Circuit

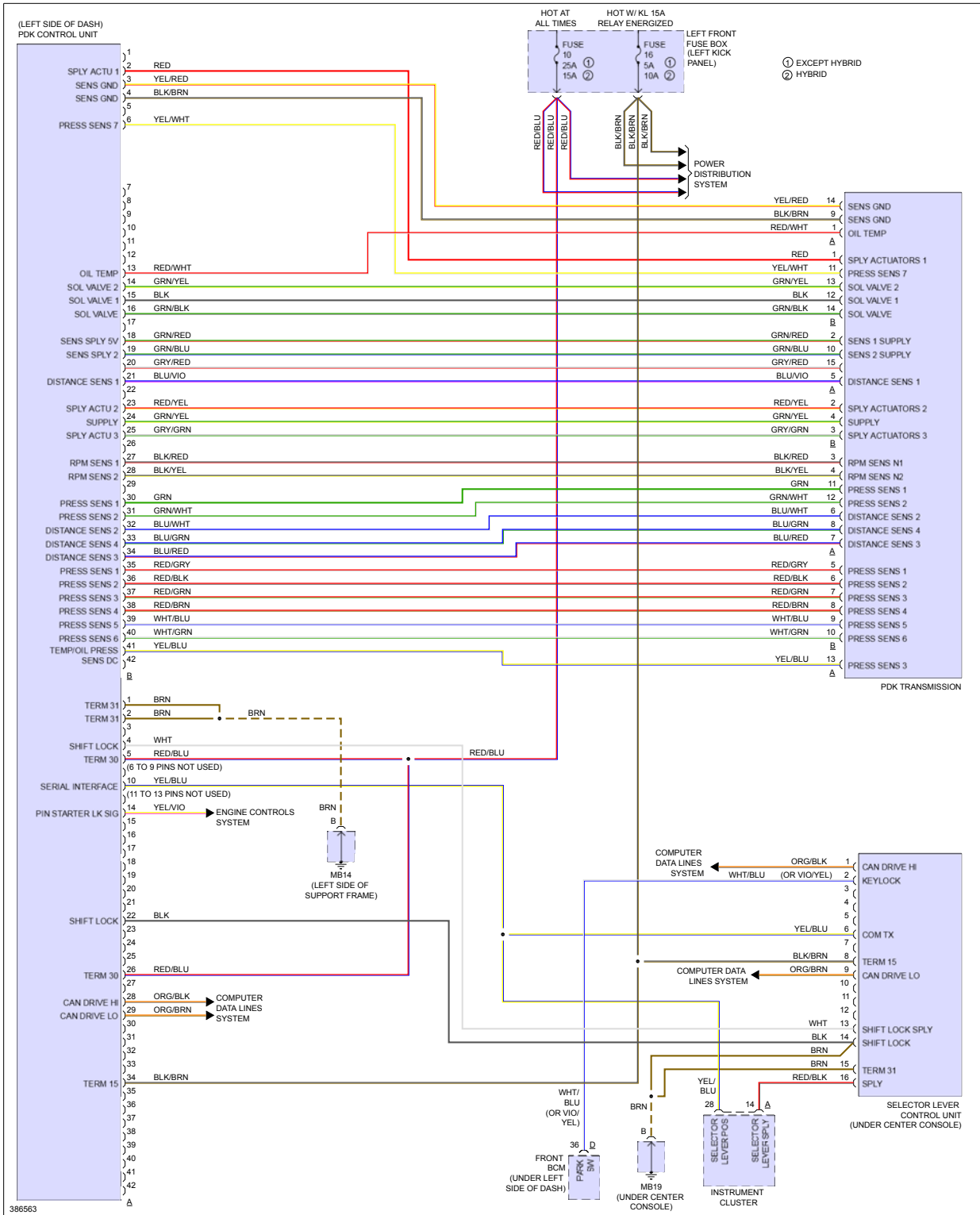
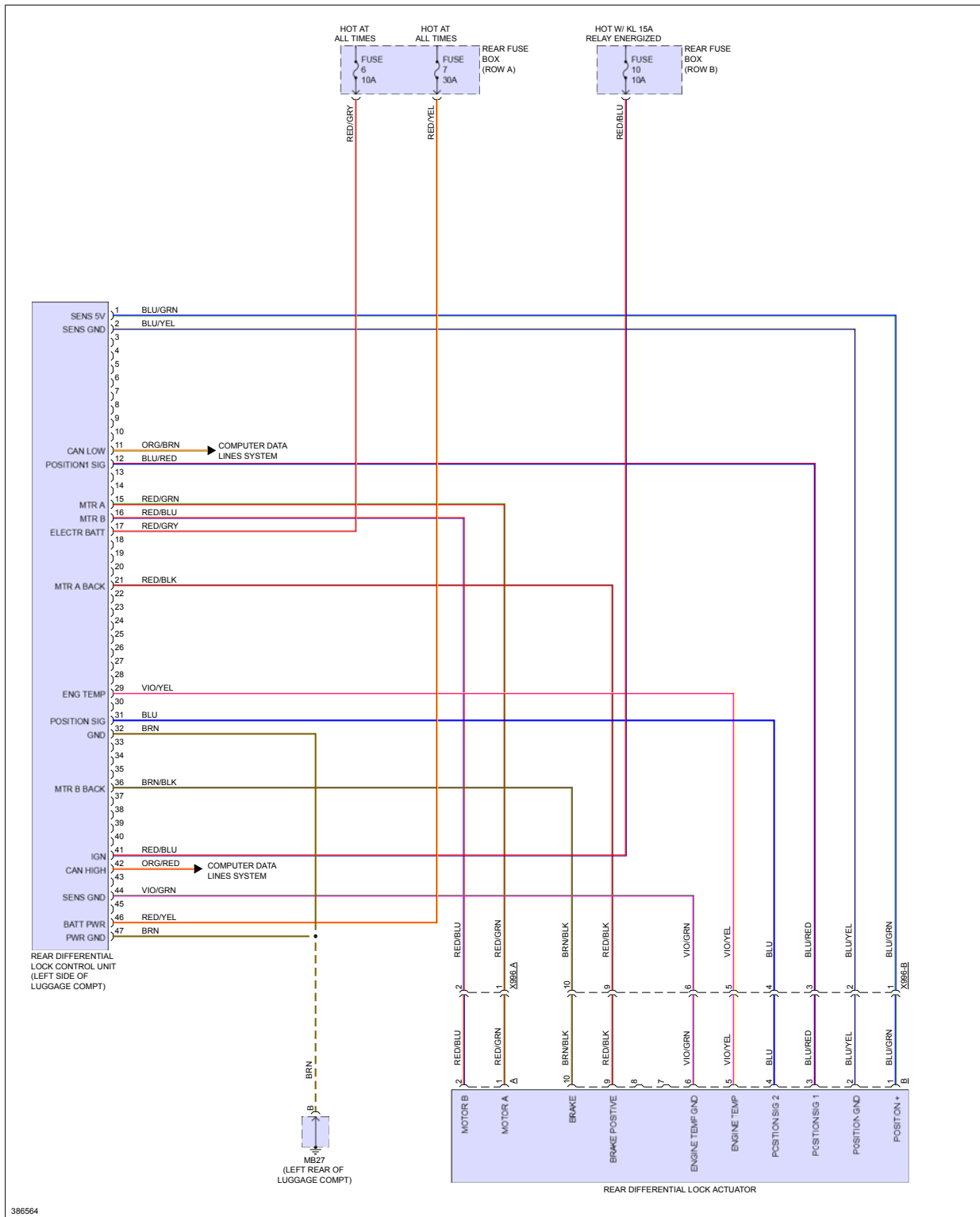

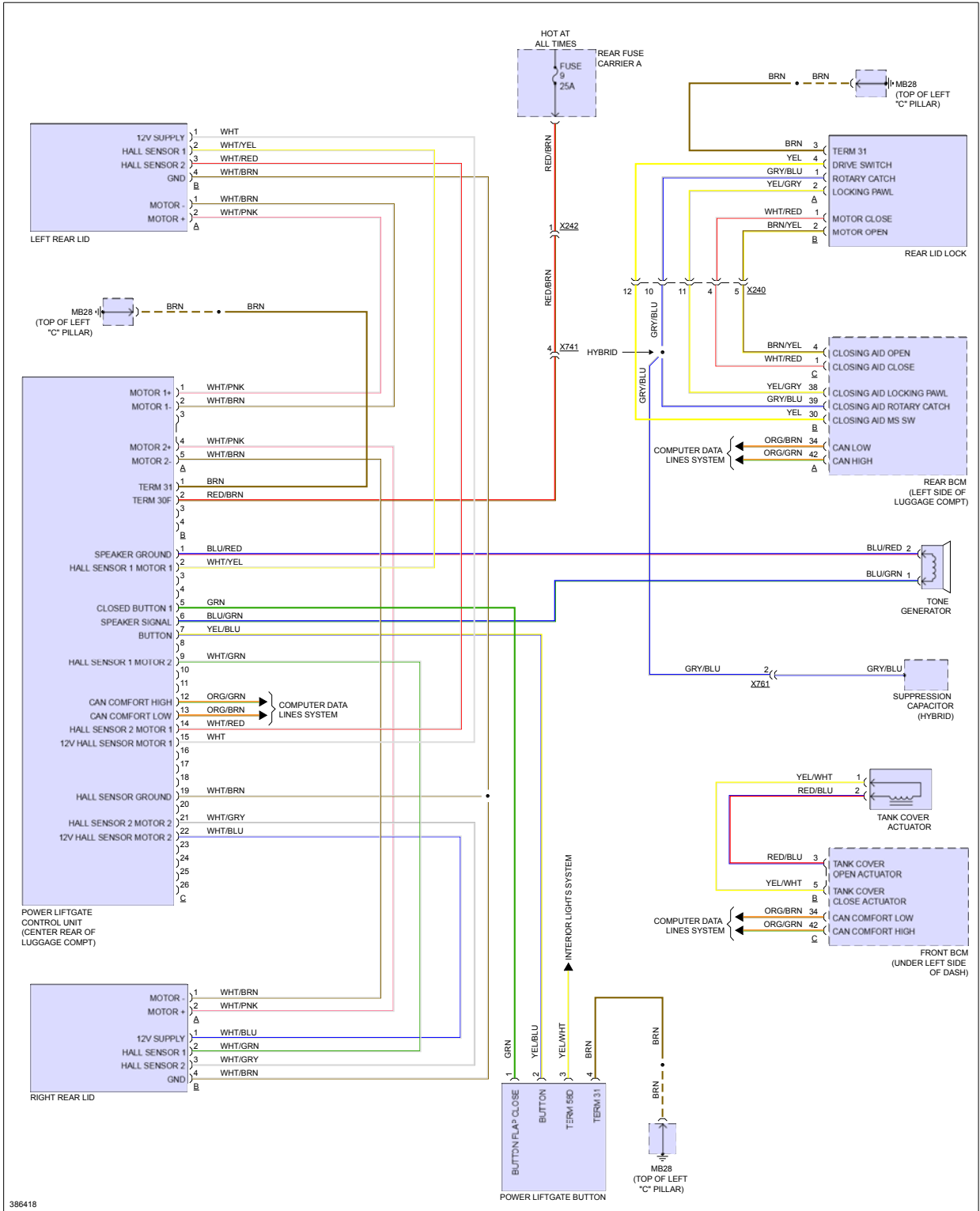

Fig 4: Rear Differential Lock Circuit



# TRUNK, TAILGATE, FUEL DOOR

Fig 1: Tailgate & Fuel Door Release Circuit



# WARNING SYSTEMS

Fig 1: Warning Systems Circuit

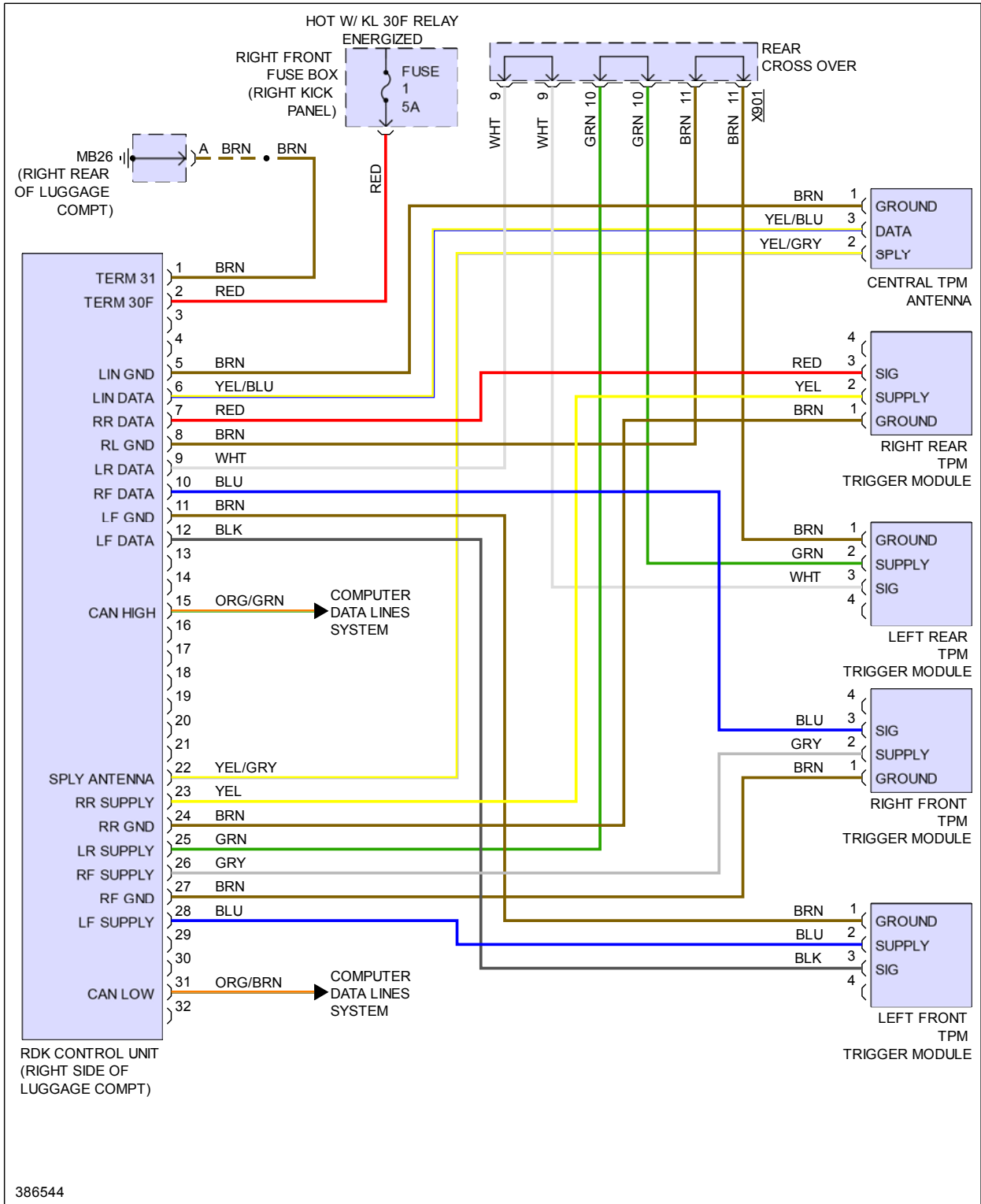

# WIPER/WASHER

Fig 1: Front Wiper/Washer Circuit

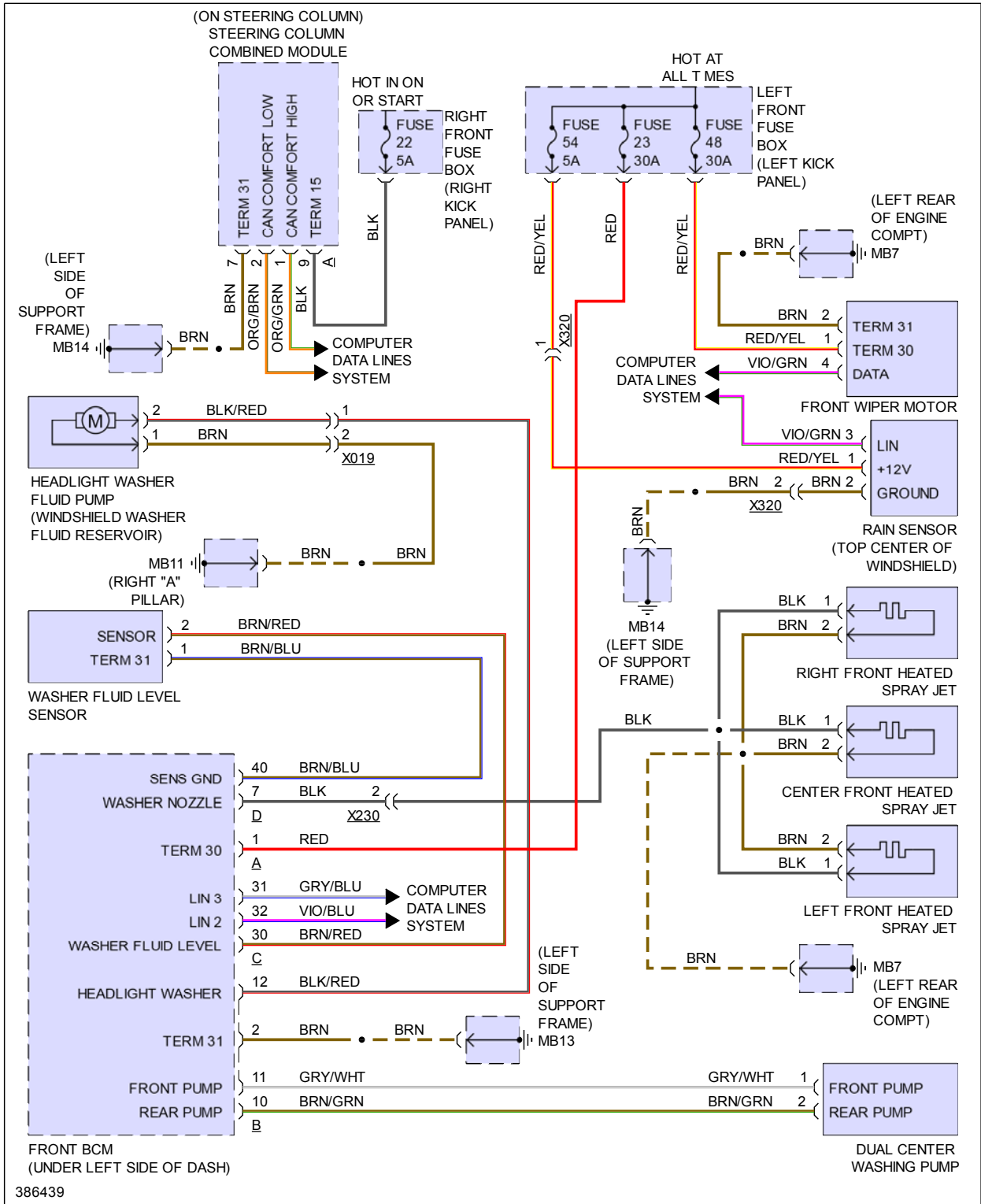
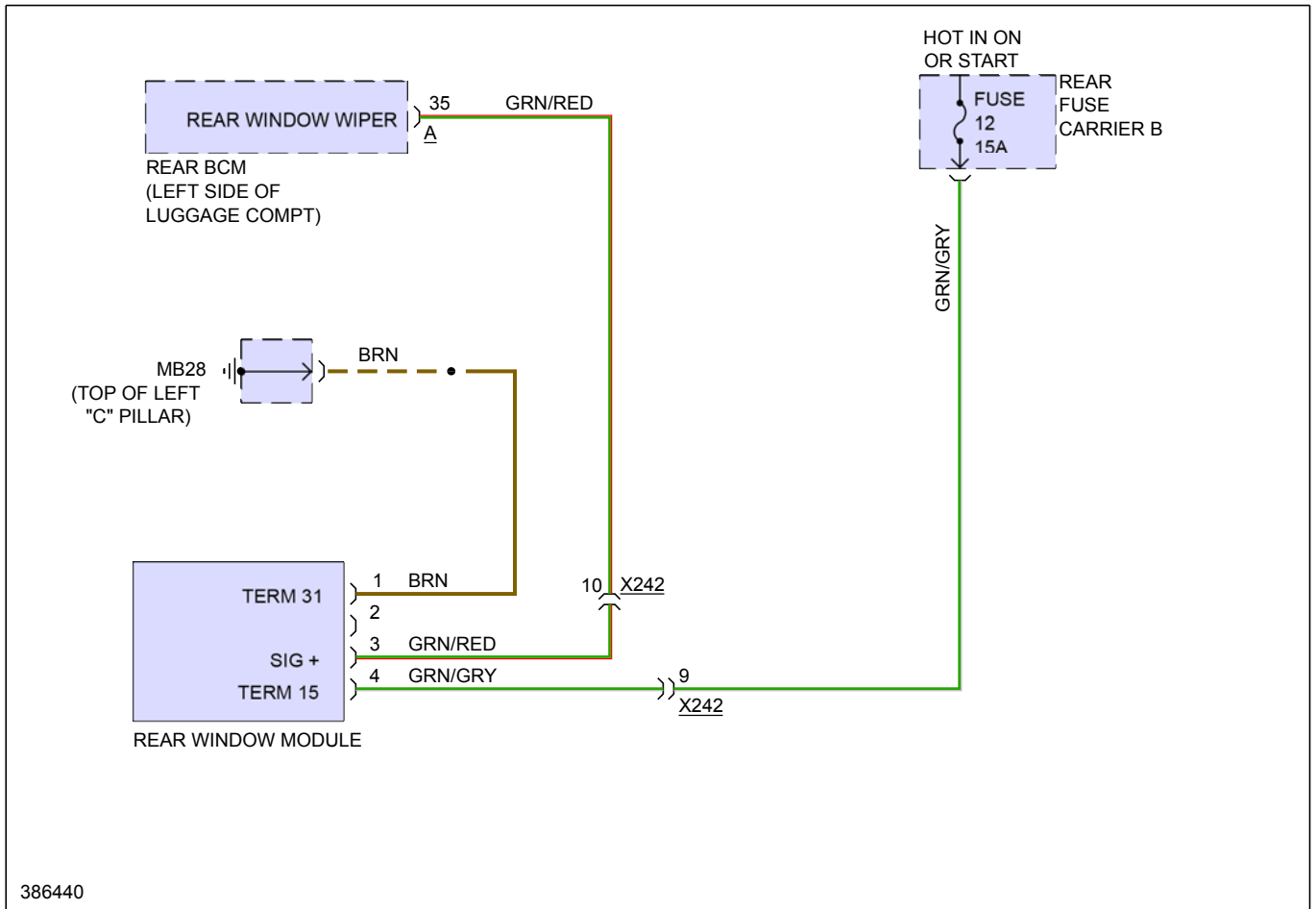

Fig 2: Rear Wiper Circuit



386440

