

Sensors

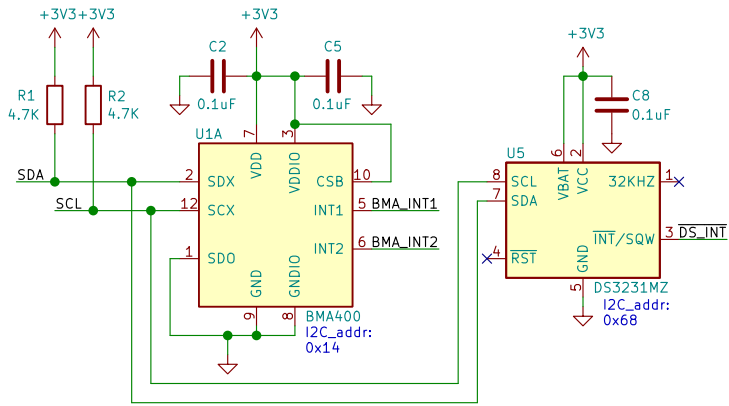

LIPO Charger

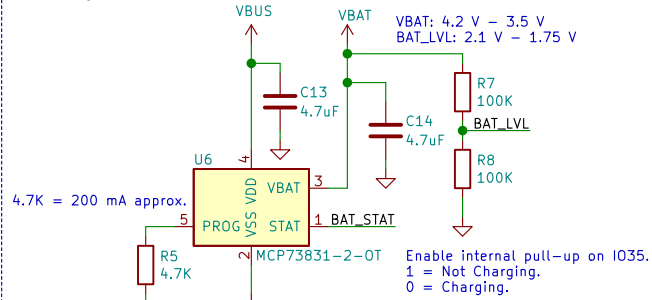

Vibration Motor

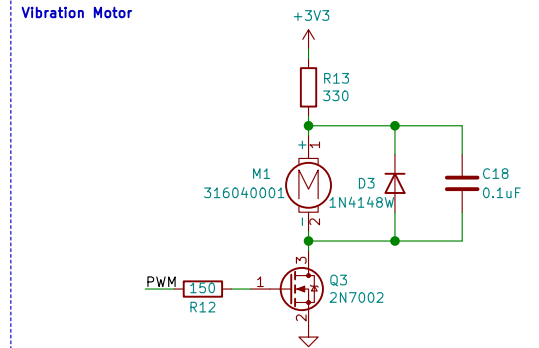

USB-Serial

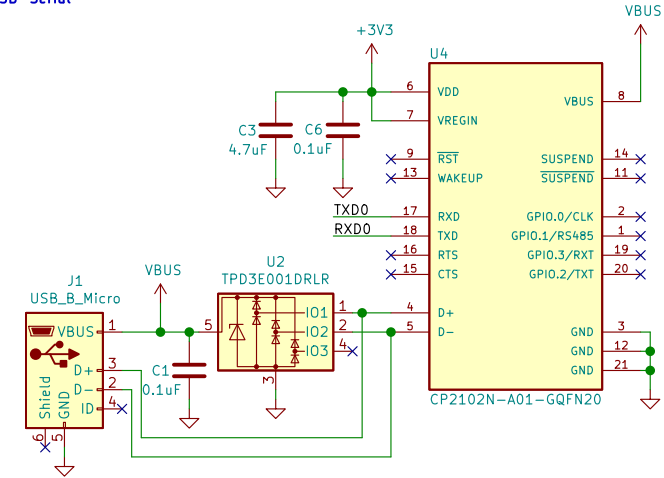

ESP32-PICO-D4

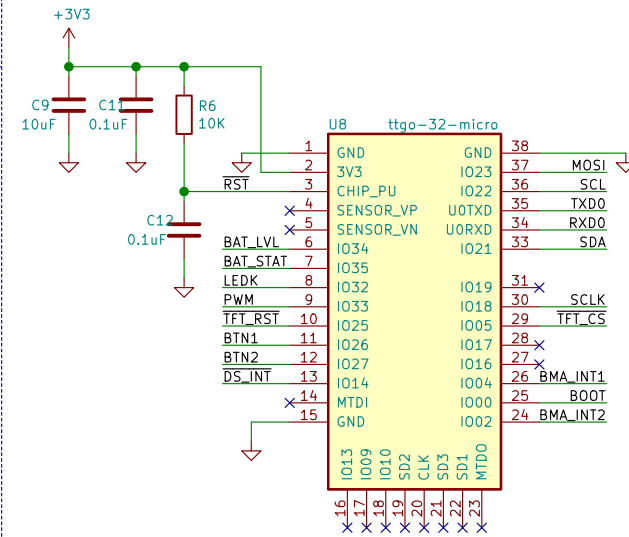

Buttons

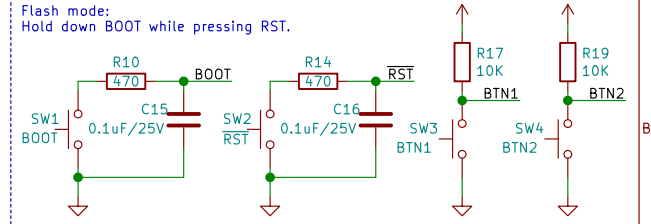

Display

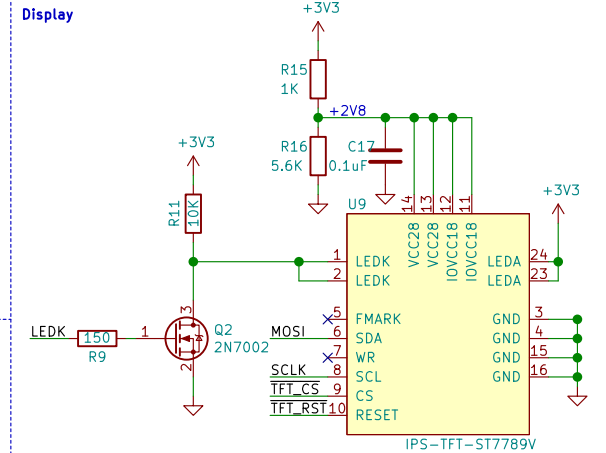

Voltage Regulation

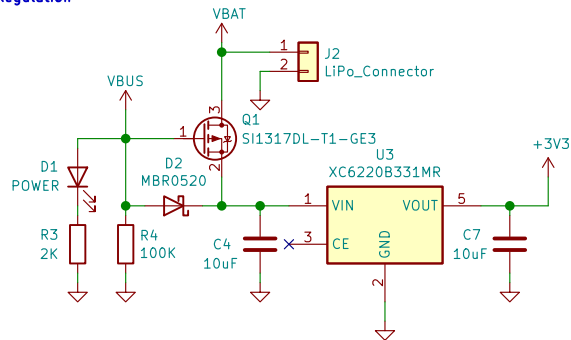

Voltage Supervisor

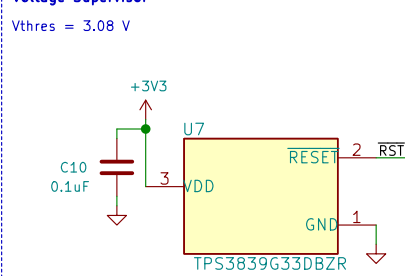

Sheet: /
File: esp32-smartwatch.sch
Title: Personal ESP32 Smartwatch

Size: A4 Date: 2021-06-18
KiCad E.D.A. kicad (5.1.10)-1

Rev: 1.0
Id: 1/1