

## Robot Welding Torch System ABIROB® W



### ABIROB® W – Robot welding torch system ...

**The universal MIG/MAG-torch system for robot welding:** A new interface and cable assembly technology for liquid cooled applications in the robot welding process. Optimally adapted to the latest market demands, ABIROB® W provides everything needed for universal, heavy-duty use in automated and robot-supported MIG/MAG welding. Cost-effective, durable and reproducible.

#### Features:

- MIG/MAG robot torch system up to 500 A
- Neck change within seconds right onto the cable assembly using the high grip counter nut
- Large variety of mounting arms in connection with the torch mount CAT2-HL available
- Large choice of standard torch necks for the most common applications



# Welding Torch System ABIROB® W

## System overview

**Fig. 1:**  
Torch interface

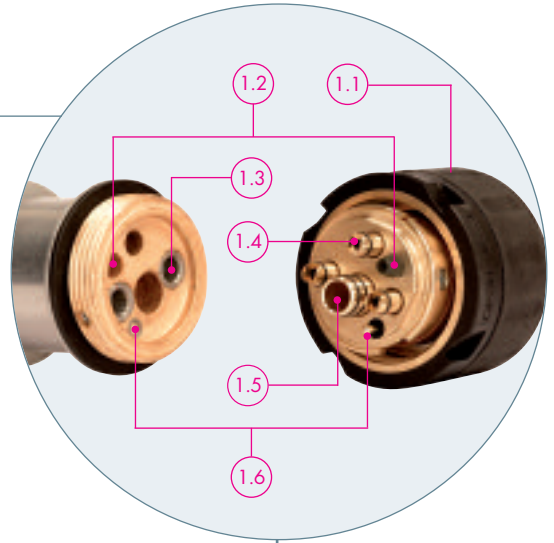

**Fig. 2:**  
Cable assembly interface

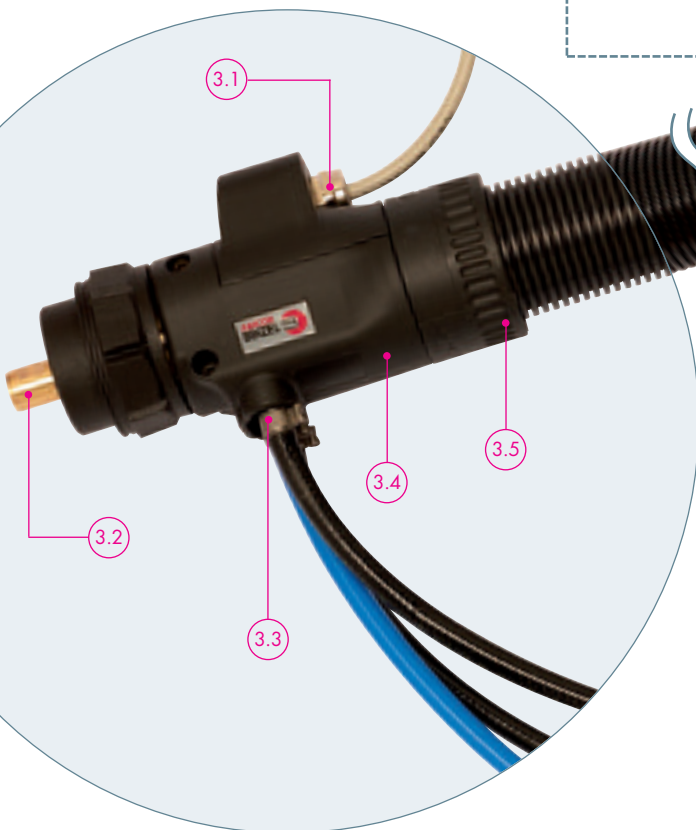
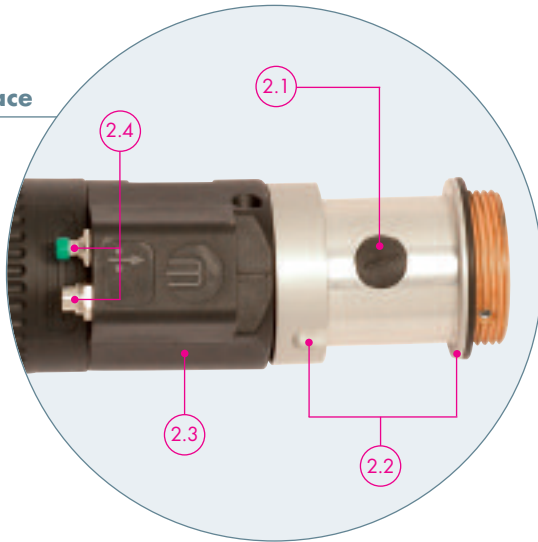

**Fig. 3:**  
Machine connection

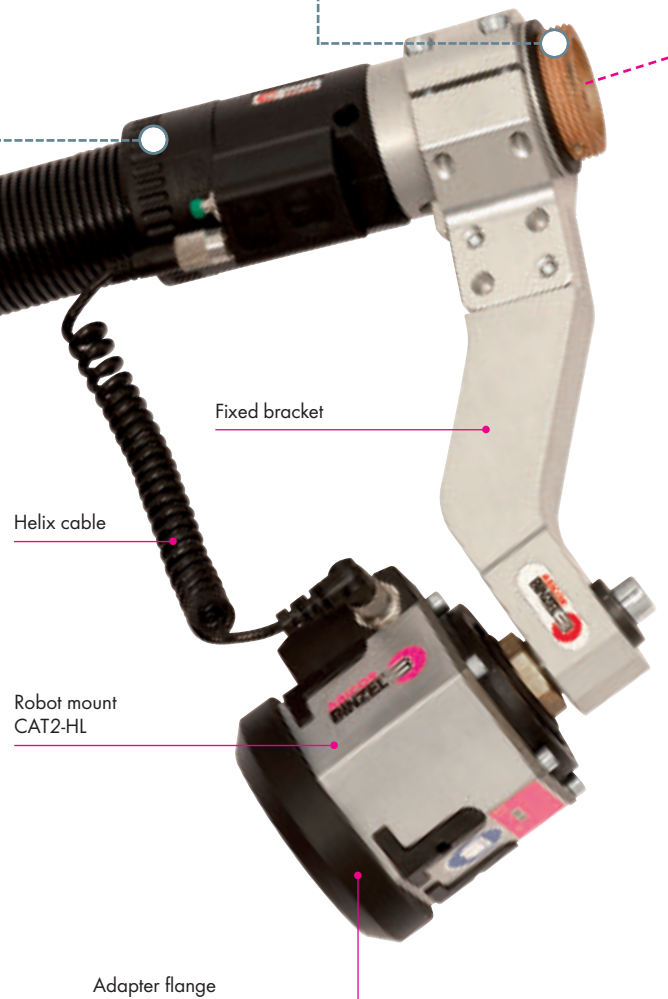

# Technical data

## Technical data (EN 60 974-7):

### Torch neck ABIROB® W 500

Type of cooling:	liquid cooled
Rating:	500 A Mixed gases M21 (DIN EN 439)
Duty cycle:	100 %
Wire size:	0.8 - 1.6 mm
Torch geometry:	0°/22°/35°/45°

### Torch neck ABIROB® W 300

Type of cooling:	liquid cooled
Rating:	300 A Mixed gases M21 (DIN EN 439)
Duty cycle:	100 %
Wire size:	0.8 - 1.2 mm
Torch geometry:	22°/45°

### Cable assembly ABIROB® W5H

Rating:	500 A
Cable type:	hybrid (see page 6)
Water flow rate:	1.9 l/min.
Gas flow rate:	25 l/min.

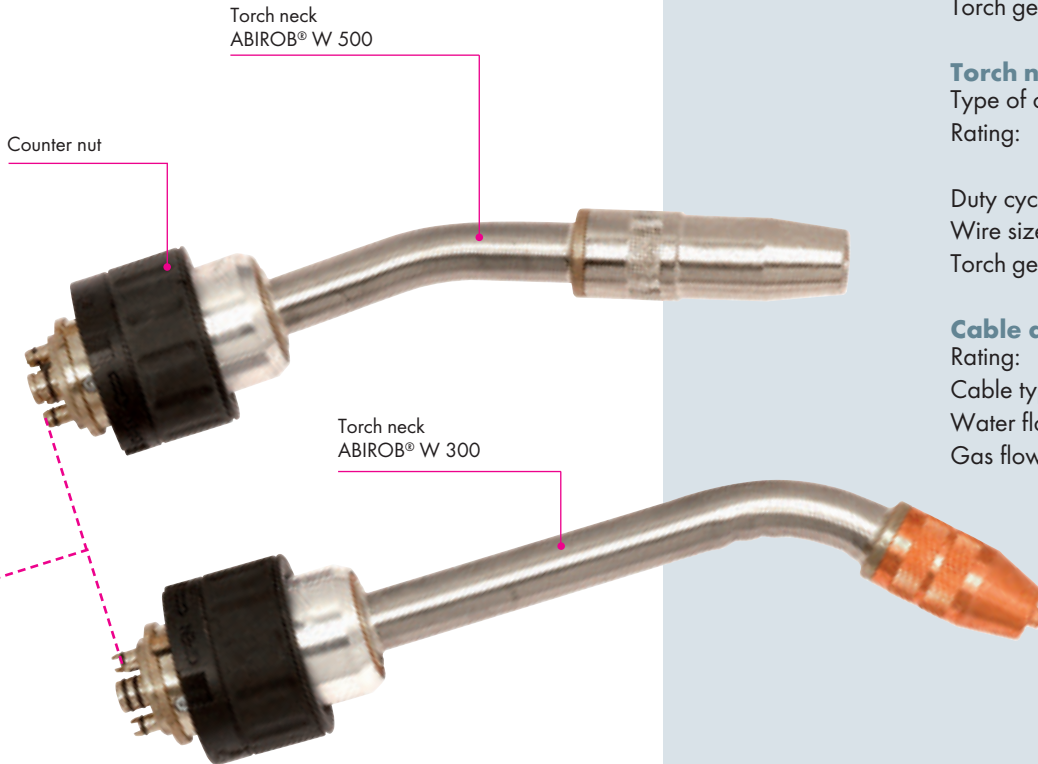

**Fig. 1:**  
Torch interface

- 1.1 High-grip connection nut – for a fast and tight connection
- 1.2 Diamond head pin connection – for a reproducible torch neck change
- 1.3 Flow check valves – no leaking of the cooling liquid during torch neck change process
- 1.4 Gas and airblast – best gas shielding
- 1.5 One piece liner / neck liner on request
- 1.6 Gas nozzle sensor<sup>1)</sup>

**Fig. 2:**  
Cable assembly interface

- 2.1 Option: Connection for wire clamp <sup>2)</sup>; on request
- 2.2 INTERLOCK connection – reproducible cable assembly position in three dimensions
- 2.3 Short housing for best accessibility
- 2.4 Connection CAT2-HL; wire inching trigger

**Fig. 3:**  
Machine connection

- 3.1 Control cable with strain relief
- 3.2 Machine connection available for all common wire feeders
- 3.3 Straight discharge for cooling liquid and airblast hose – no bending or twisting
- 3.4 Short connection housing – high flexibility of the cable assembly
- 3.5 Rotatable outer hose connection – minimized torsion stress

#### Note concerning technical data:

Ratings determined under standard conditions at medium level of heat reflection, free air circulation and 28 °C ambient temperature. In applications with more demanding conditions the rating must be reduced by 10-20 %.

For pulsed arc welding the rating must be reduced by up to 35%.

<sup>1)</sup> Torch necks to be supplied with and without gas nozzle sensor; gas nozzle sensor connection is used for tactile seam location via gas nozzle. Please ask your robot manufacturer.

<sup>2)</sup> Wire clamp is used for tactile seam location via welding wire. Please ask your robot manufacturer.

# Welding Torch System ABIROB® W

## Torch necks, accessories & wear parts

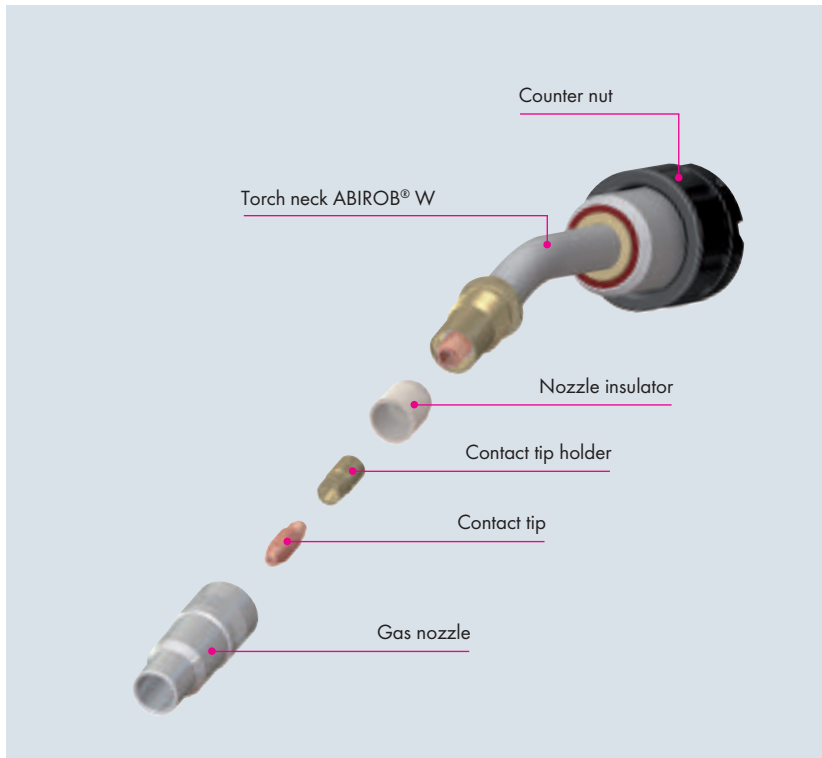

ABICOR BINZEL robot torch necks ABIROB® W distinguish themselves through their high stability and long life. Besides the standard geometries there is also a variety of special torches, which we manufacture to order for our customers.

### Torch neck ABIROB® W 500

- Versatile adaptable, robust allrounder
- Power ratings up to 500 A
- Screw-on gas nozzle
- Replacable contact tip holder
- Eight standard torch geometries available

### Torch neck ABIROB® W 300

- Especially suitable for applications with accessibility problems
- Power ratings up to 300 A
- Slender torch head
- Screw-on gas nozzle
- Replacable contact tip holder
- Two standard torch geometries available

Torch neck Type	Equipment	Part-No.			
		0°	22°	35°	45°
ABIROB® W 500	Gas nozzle sensor	782.0079	782.0003	782.0004	782.0005
ABIROB® W 500		782.0080	782.0076	782.0077	782.0078
ABIROB® W 500 (+100 mm)	Gas nozzle sensor	782.0088.1	782.0089.1	782.0090.1	782.0091.1
ABIROB® W 500 (+100 mm)		782.0106.1	782.0107.1	782.0108.1	782.0109.1
ABIROB® W 300	Gas nozzle sensor	-	782.0014	-	782.0015
ABIROB® W 300		-	782.0110.1	-	782.0111.1

Wear and spare parts are not included in the delivery! Please order separately and according to the application!



### Accessories

Typ	Part-No.
1 Thread cutter M10x1 (for inner tube)	191.0085
2 Alignment tool (to align inner tube with outer tube)	191.0090
3 Pin wrench (to unscrew counter nut)	191.0115



### Alignment jig

Torch type	Torch geometry	Part-No.
ABIROB® W 500	0° / 22° / 35° / 45°	837.0589.1
ABIROB® W 500 (+100 mm)	0° / 22° / 35° / 45°	837.0735.1
ABIROB® W 300	22° / 45°	837.0484.1

# Welding Torch System ABIROB® W

## Wear parts

### ABIROB® W 300

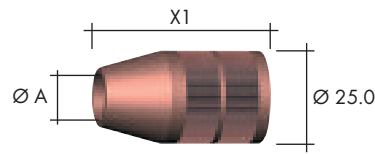

### ABIROB® W 500

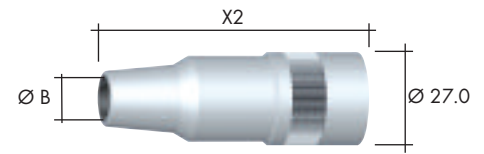

#### Gas nozzle bottle form (10 pcs.)

	Ø A	X1		Ø B	X2	
"RECESS" (- 2.6 mm) <sup>2)</sup>	Ø 13.0	-	-	Ø 13.0	77.0 mm	145.0556
"RECESS" (- 1.1 mm) <sup>2)</sup>	Ø 13.0	-	-	Ø 13.0	75.5 mm	145.0479
"RECESS" (- 2.6 mm) <sup>2)</sup>	Ø 15.5	-	-	Ø 15.5	77.0 mm	145.0480
"RECESS" (- 1.1 mm) <sup>2)</sup>	Ø 15.5	-	-	Ø 15.5	75.5 mm	145.0544
"STICK OUT" (+ 2.4 mm) <sup>3)</sup>	Ø 15.5	-	-	Ø 15.5	72.0 mm	145.0466

#### Gas nozzle conical (10 pcs.)

	Ø A	X1		Ø B	X2	
"RECESS" (- 1.0 mm) <sup>2)</sup>	Ø 13.0	48.5 mm	145.0564	Ø 13.0	-	-
"STICK OUT" (+ 3.0 mm) <sup>3)</sup>	Ø 13.0	44.5 mm	145.0495	Ø 13.0	-	-
"STICK OUT" (+ 3.0 mm) <sup>3)</sup>	Ø 15.5	44.5 mm	145.0494	Ø 15.5	-	-
"RECESS" (- 1.1 mm) <sup>2)</sup>	Ø 15.5	-	-	Ø 15.5	75.5 mm	145.0553
"STICK OUT" (+ 1.9 mm) <sup>3)</sup>	Ø 15.5	-	-	Ø 15.5	72.5 mm	145.0568

1) FLUSH =  
Contact tip  
flushed



2) RECESS =  
Contact tip  
standing back



3) STICK OUT =  
Contact tip  
protruding

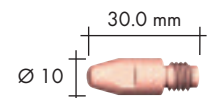
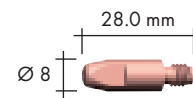
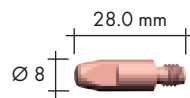

#### Contact tip (10 pcs.)

	Ø	M6	M6	M8
CuCrZr	Ø 0.8	140.0054	140.0054	140.0117
	Ø 0.9	140.0172	140.0172	140.0217
	Ø 1.0	140.0245	140.0245	140.0316
	Ø 1.2	140.0382	140.0382	140.0445
	Ø 1.4	-	-	140.0536
	Ø 1.6	-	-	140.0590

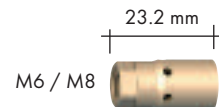
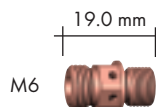

#### Contact tip holder (10 pcs.)

	M6	M6 / M8
M6 brass	-	-
M8 brass	-	142.0117
M6 Cu*	785.5052	142.0133
M8 Cu*	-	142.0151

\*Recommended for high amp ratings.

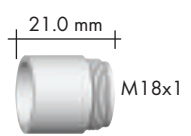
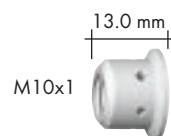

#### Gas diffuser (10 pcs.)

#### Nozzle insulator (10 pcs.)

	Gas diffuser	Gas diffuser	Nozzle insulator
Standard	962.0657	943.0284	146.0054
Standard short (L=11,4 mm)	-	-	146.0064**
High-temperature-resistant	962.1341 (Ceramic)	-	146.0059

\*\*Recommended for applications with galvanized materials. Use with gas nozzle 145.0553 and 145.0568.

Neck-liner on request.



# Welding Torch System ABIROB® W

## Cable assemblies & Liner

All illustrated cable assemblies are hybrid style. The current carrying cable is a so-called BIKOX (coaxial) cable. Compared to conventional cable packages with power/water cable the hybrid version offers many advantages resulting in a long lifetime.

### Advantages:

- Higher stiffness – better wire guidance
- No electrolytic corrosion – less sedimentation
- No cable defect in the case of cooling pump failure
- Improved water flow by separate hoses
- Easy maintenance and repair

### Cable assemblies ABIROB® W5H with Euro central connector

Length	L=1.10 m	L=1.20 m	L=1.25 m	L=1.30 m	L=1.35 m	L=1.45 m
Part-No.	782.1014.1	782.1015.1	782.1016.1	782.1017.1	782.1018.1	782.1019.1

Length	L=1.50 m	L=1.60 m	L=1.65 m	L=2.65 m	L=3.15 m
Part-No.	782.1020.1	782.1021.1	782.1022.1	782.1023.1	782.1024.1

### Cable assemblies ABIROB® W5H with Panasonic® style connector

Length	L=1.10 m	L=1.20 m	L=1.25 m	L=1.30 m	L=1.35 m	L=1.45 m
Part-No.	782.1029.1	782.1030.1	782.1031.1	782.1032.1	782.1033.1	782.1034.1

Length	L=1.50 m	L=1.60 m	L=1.65 m	L=2.65 m	L=3.15 m
Part-No.	782.1035.1	782.1036.1	782.1037.1	782.1038.1	782.1039.1

Length of more than 3.15 m on request. Will be delivered with power/water cable.

The control cable is not pre-wired on the machine end. Power source specific types on request. Included in delivery is liner red 0.8-1.2 mm. Other liner please order separately.

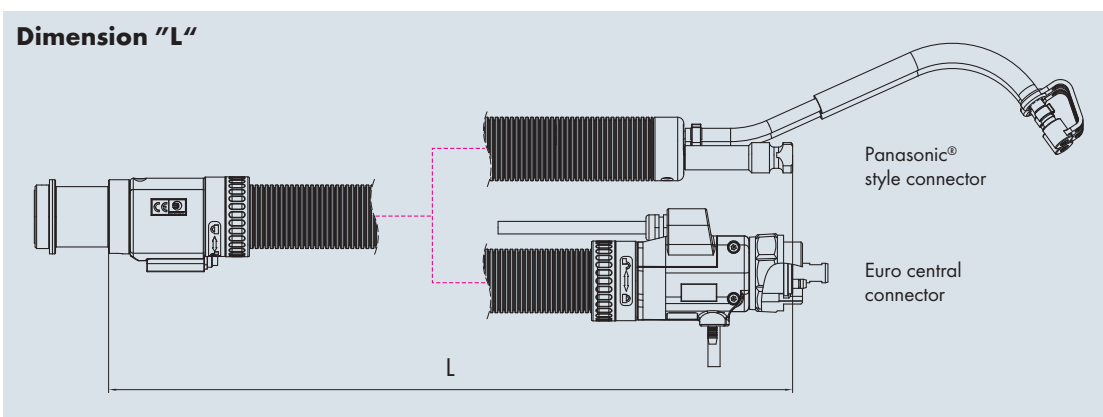

### Liner for Euro central connector

Type	Wire size	up to L=1.5 m <sup>3)</sup>	up to L=3.15 m <sup>3)</sup>	Bulk, 10.0 m	Collet/Retaining nipple
Liner steel red <sup>1)</sup>	Ø 0,8-1,2	124.0145	124.0146	124.0159 <sup>4)</sup>	131.0012
Liner steel white <sup>1)</sup>	Ø 1,4-1,6	124.0147	124.0148	124.0160 <sup>4)</sup>	131.0011
Combi-liner <sup>2)</sup>	Ø 0,8-1,2	128.M008	128.M009	-	131.0019
	Ø 1,4-1,6	128.M012	128.M013	-	131.0020

### Liner for Panasonic® style connector

Liner steel red <sup>1)</sup>	Ø 0,8-1,2	124.0189.1	124.0190.1	-	-
Liner steel white <sup>1)</sup>	Ø 1,4-1,6	124.0185	124.0191.1	-	-
Combi-liner <sup>2)</sup>	Ø 0,8-1,2	128.M006	128.M007	-	131.0024
	Ø 1,4-1,6	128.M010	128.M011	-	131.0016

<sup>1)</sup> Red and white steel liner (insulated) for the use of non-alloyed and low-alloyed steels. The totally insulated wire feed prevents damage caused by "micro-arcing" on the wire. This allows optimal current transfer inside the contact tip improving the welding process. The insulated steel liner must be used for power sources with optional welding wire sensors.

<sup>2)</sup> Combi-liners for aluminum or bronze wires. A combination of PA liner with a front-end piece of brass liner, to avoid thermal overloading of the PA material.

<sup>3)</sup> Including one collet/nipple

<sup>4)</sup> For individual configuration including two collets/nipples

# Welding Torch System ABIROB® W

## Mounting arms and TCP geometries

### RTM holder for ABIROB® W

for robots with integrated collision software

Torch type	Torch geometry	X (mm)	Y (mm)	h (mm)	$\alpha$	Part-No.
ABIROB®	22°	400	0	153	45°	780.0449.1
W 500	35°	400	0	125	45°	780.0451.1
	45°	400	0	105	50°	780.0453.1
ABIROB®	22°	500	0	192	45°	780.0455.1
W 500	35°	500	0	142	45°	780.0457.1
(+100 mm)	45°	500	0	105	45°	780.0453.1
ABIROB®	22°	400	0	149	45°	780.0459.1
W 300	45°	400	0	90	50°	780.0461.1

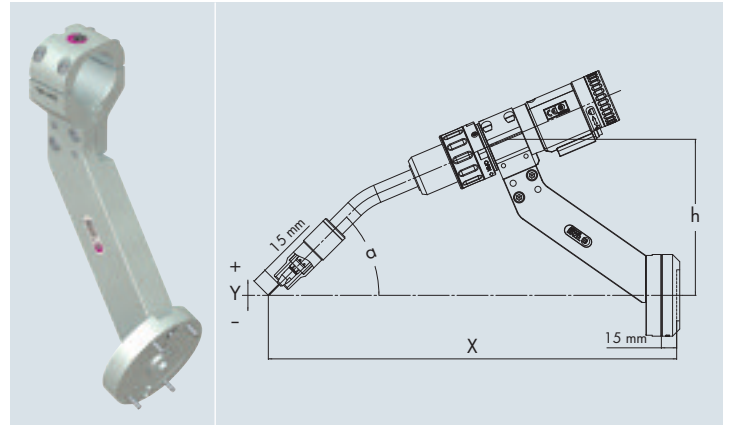

### Fixed bracket for ABIROB® W

in connection with CAT2-HL

Torch type	Torch geometry	X (mm)	Y (mm)	h (mm)	$\alpha$	Part-No.
ABIROB®	22°	400	0	153	45°	780.0414.1
W 500	35°	400	0	125	45°	780.0420.1
	45°	400	0	126	50°	780.0422.1
ABIROB®	22°	500	0	192	45°	780.0438.1
W 500	35°	500	0	142	45°	780.0440.1
(+100 mm)	45°	500	0	134	50°	780.0442.1
ABIROB®	22°	400	0	149	45°	780.0444.1
W 300	45°	400	0	90	50°	780.0446.1

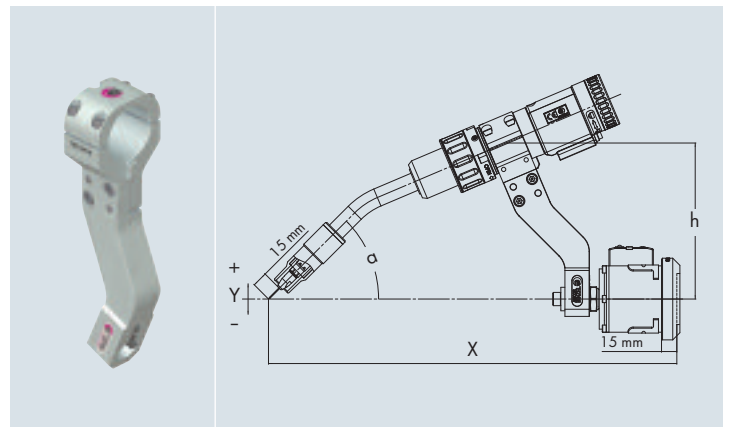

### Segment holder for ABIROB® W (Raster 7.5°)

in connection with CAT2-HL

Torch type	Torch geometry	X (mm)	Y (mm)	h (mm)	$\alpha$	Part-No.
ABIROB®	22°	400	0	115	36°	780.0433.1
W 500	35°	383	0	117	43°	780.0433.1
	45°	368	0	118	48°	780.0433.1
ABIROB®	22°	497	-24	115	36°	780.0433.1
W 500	35°	475	-51	115	49°	780.0433.1
(+100 mm)	45°	453	-70	115	59°	780.0433.1
ABIROB®	22°	440	+10	115	36°	780.0433.1
W 300	45°	413	-19	115	59°	780.0433.1

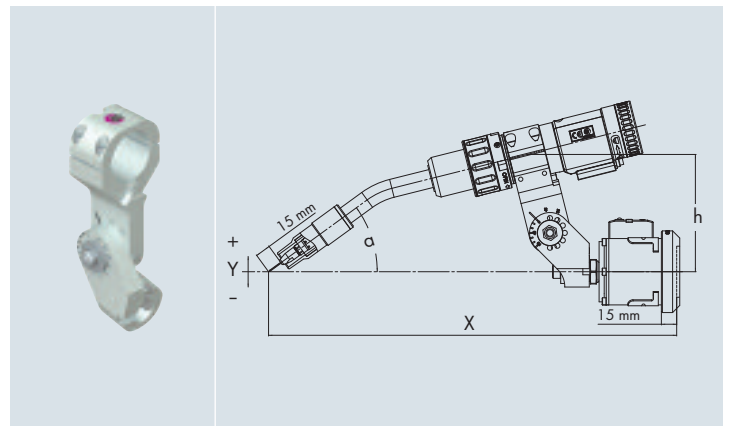

### Holder CAT2-HL for ABIROB® W

in connection with CAT2-HL

Torch type	Torch geometry	X (mm)	Y (mm)	h (mm)	$\alpha$	Part-No.
ABIROB®	22°	399	0	103	33°	780.0430.1
W 500	35°	383	0	104	40°	780.0430.1
	45°	370	0	105	45°	780.0430.1
ABIROB®	22°	499	0	104	30°	780.0430.1
W 500	35°	484	0	105	39°	780.0430.1
(+100 mm)	45°	470	0	105	45°	780.0430.1
ABIROB®	22°	437	0	102	36°	780.0430.1
W 300	45°	416	0	104	53°	780.0430.1

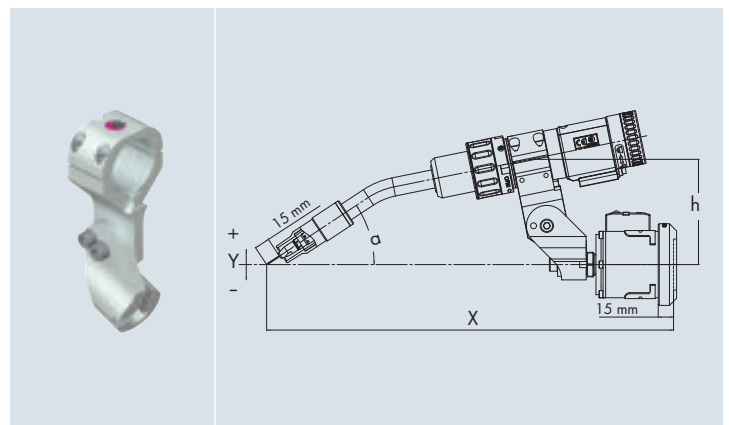

Other mountings on request.

**Please note:** All trademarks mentioned are property of the respective companies.

# Welding Torch System ABIROB® W

## Robot mount CAT2-HL

CAT2-HL is based on the well-proven robot mount CAT2 with improved fixing section for torch mounts. Together with the product introduction of the welding torch system ABIROB® W, CAT2-HL is used as a standard robot mount for the first time. All mounts of the ABIROB® W-series are equipped with the solid and highly precise conical connection for CAT2-HL.

### Features:

- Outer dimensions compatible with CAT2
- Adapter flanges
- Firm structural construction for best reproducibility
- Easy and fast assembly and disassembly

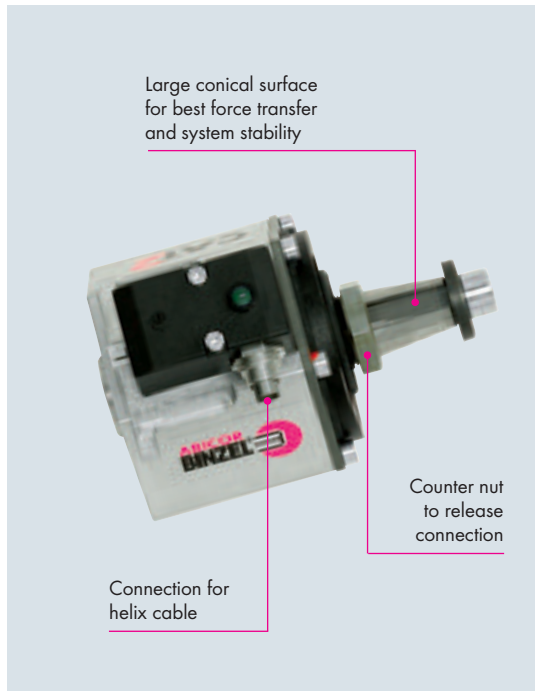

### Robot mount CAT2-HL

Description	Part-No.
Robot mount CAT2-HL (M)	780.2041
Robot mount CAT2-HL (L)	780.2042
Robot mount CAT2-HL (XL)	780.2040
Helix cable cpl. (Connection CAT2-HL to cable assembly)	780.0201

### Adapter flange

(Plastic, insulated)

Description	Part-No.
ISO 9409-1-A31,5	780.0632
ISO 9409-1-A40	780.0691
ISO 9409-1-A50	780.0694.1
ISO 9409-1-A63	780.0614
ISO 9409-1-A80	780.0607
ISO 9409-1-A100	780.0649
ISO 9409-1-A125	780.0630

Adapter flanges can be delivered for all common welding robots. Please indicate type and model of robot.

## TIPS & TRICKS

CAT2-HL (L) with spring tension L is recommended for applications with wire feeders mounted on the robot arm. For long cable assemblies (high dynamic load) or in case of extreme robot movements and positions, CAT2-HL (XL) with spring tension XL should be used.



Alexander Binzel Schweisstechnik GmbH & Co. KG  
P.O. Box 10 01 53 · D-35331 Gießen  
Phone: +49 (0) 64 08 / 59-0  
Fax: +49 (0) 64 08 / 59-191  
Email: info@binzel-abicor.com

[www.binzel-abicor.com](http://www.binzel-abicor.com)