

Model ECH30

- 6" - 14 gauge spun aluminum ball gold anodized
- Single sheave truck, cast aluminum revolving, non-fouling type
- 2 Swivel snaps with covers per halyard
- 1 Set of halyard: #10 poly

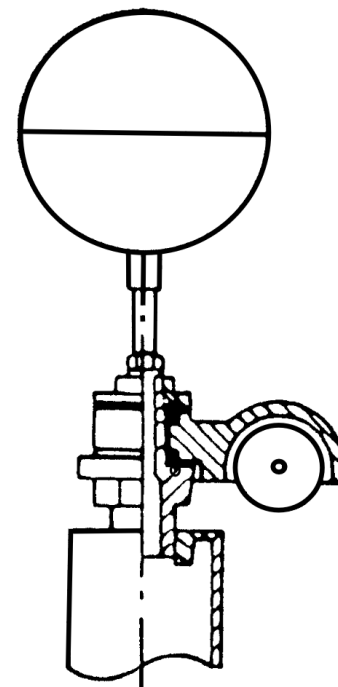

Truck Detail

- Aluminum body
- Stainless steel ball bearings
- Aluminum sheave
- Cast aluminum spindle

1 - 9" Cast aluminum cleat

Aluminum flash collar

3000 PSI concrete

Hardwood wedges (supplied by others)

Dry sand tightly tamped after aligning pole

Foundation sleeve - 16 ga hot dip galvanized steel

Steel centering wedges

1/4" Steel base plate

1/4" Steel support plate welded to grounding spike

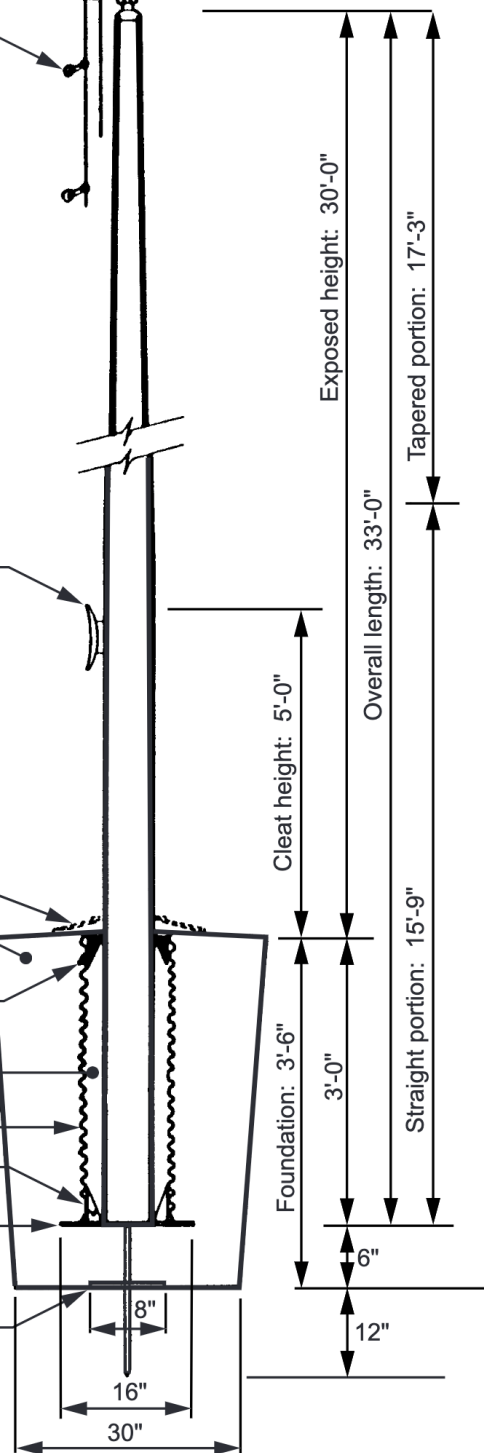

All shafts with overall length of more than 38'-6" are shipped in two sections.

Each section matched marked for field assembly. Exposed portion of jam sleeve must be **well lubricated** prior to assembly.

1-1/2" maximum shop gap allowed for field fitting (ram for tight joint)



Project:	Ground set tapered aluminum flagpole: ALLOY: 6063T6	FLAGS.COM	Date:
Location:	Exposed height: 30'-0"	Overall height: 33'-0"	Revision:
Architect:	Ship in 1 section	Butt diameter: 6"	
Contractor:	Top diameter: 3-1/2"	Wall thickness: .250"	
Customer:	Finish: 100 grit polish		