

\$8.00



XL23



OPERATIONS GUIDE



CONGRATULATIONS!

Congratulations on being the owner of a new XL 23 ceramic kiln with CRESS FIREMATE[®], the safest and newest automatic kiln on the market today. Your kiln gives you the fastest most energy efficient firing possible with the least amount of heat shock because it gradually increases power throughout the process, unlike the heat shocking step increases achieved by other automatic kilns. Your appliance senses and adjusts for room temperature and small voltage changes incoming to your home giving you more repeatable and more consistent firing results than any other hobby kiln on the market. Unlike most other kilns, the elements from top to bottom are each factory heat balanced electrically to give the most uniform firing possible. The FIREMATE[®] has been patented in 16 countries for its excellent and unique control system.

The use of firebrick will give you the slowness in firing that museum quality art requires while the FIREMATE[®] has the unique ability to add more speed to the the age-old process without hurting the quality of the ware. The TURBO FIRE[™] feature gives you enhanced firing speed taking full advantage of the low heat shock FIREMATE[®] firing characteristics.

Cress has been at the forefront of firing processes for over 42 years. Cress was first in our field with UL listing of ceramic kilns, first with ultra reliable element connections, first with infinitely variable power controls, first with inexpensive automated firing, and now first with multi-speed enhanced firing. Cress manufactured the high temperature furnaces to test reentry nose cones for the first space vehicles and also produced ceramic kilns used to make the Space Shuttle tiles.

We sincerely wish you many years of creative and rewarding use of your CRESS FIREMATE[®] kiln.

CRESS MANUFACTURING COMPANY, INC.
1718 Floradale Avenue, South El Monte, CA 91733

Copyright February 1988 by Cress Manufacturing Company, Inc. All rights are reserved.



TABLE OF CONTENTS

CONGRATULATIONS!	i
NOTICE	1-1
UNPACKING INSTRUCTIONS	1-2
KILN INSTALLATION / Placement	1-3
ELECTRICAL SPECIFICATIONS	2-1
KILN ACCESSORIES / Kiln Wash	3-1
Kiln Furniture	3-1
Stilts	3-1
Pyrometric Cones and Cone Holders	3-2
Pyrometers	3-2
KILN OPERATION	4-1
Shut-Off Devices	4-2
Kiln Sitter®	4-2
Adjustments	4-3
Kiln Sitter® Operation	4-5
Limit Timer	4-5
Limit Timer Operation	4-6
Lid Brace	4-6
Lid Prop	4-6
FIREMATE® POWER CONTROL / Thumbwheel Power Control Switch	5-1
Firemate® Speed Control	5-1
Pilot Lights	5-1
PREPARATION FOR FIRING	6-1
LOADING	7-1
FIRING / Methods Of Temperature Indication	8-1
Pyrometric Cones	8-1
The Pyrometer	8-4
Firing Ceramics	8-3
Firing Glass	8-8
FIRING FOR BEST RESULTS / Recognizing Firing Faults	9-1
KILN MAINTENANCE	10-1
Lid Brace	10-2
Lid Band	10-2
Stainless Steel Case	10-2
Pilot Lights	10-2
Cord	10-2
TROUBLE SHOOTING	11-1
REPAIRS / Changing Thumbwheel Switch Or Motor	12-1
Motor Removal And Installation	12-2
Speed Control Switch Replacement	12-2
Lid Replacement	12-3
Brick Bottom Replacement	12-3
Wall Brick Replacement	12-4
Element Replacement	12-5
Thermocouple Replacement	12-6
XL23 HEAT TREATING CHART	13-1
XL23 WIRING DIAGRAM	14-1
LIMITED WARRANTY DEFINITIONS	15-1
Warranty	15-1
Remedies	15-1
Warranty Claim Requirements	15-2
Disclaimer	15-3
GLOSSARY	16-1



IMPORTANT SAFEGUARDS

Notice: Please read and observe the following safety warnings before operating your kiln.

1. Install kiln 18" or more from any wall or combustibles.
2. Fire only on stand or legs furnished.
3. Never fire hotter than the cone or temperature specified on the rating plate. (Never hotter than cone 10 or 2400°F.)
4. Do not fire hotter than the manufacturer's recommendation for your clay, glazes, or decals or permanent damage may result to your kiln or ware.
5. Do not open lid until kiln has cooled.
6. Before opening lid, turn off all switches, then carefully open lid and lock lid brace securely. Gently test that lid is securely locked in place before allowing lid to stand freely.
7. Do not leave kiln unattended while firing.
8. Never use an extension cord.
9. Operate kiln only in a well ventilated room.
10. Unplug kiln before servicing or cleaning.
11. Dangerous Voltage - Do not touch heating elements with anything.
12. Do not touch hot sides of kiln or hot lid - Burns may result.
13. Keep children away at all times.
14. Never store anything under kiln; never lean objects against kiln.
15. Do not store or use flammable liquids or sprays in the same room with your kiln.
16. Do not store or use your kiln outside - keep rain and moisture away from kiln.
17. Do not use kiln if cord is damaged or touching kiln case.
18. Wall receptacle must not be corroded or fit the plug loosely.
19. Use kiln only with adequate electrical supply - with the correct voltage, amperage and correct fuse size (not too large or small). Be sure the wire size is large enough (avoid aluminum wiring). Do not use a 208 volt kiln on 220 volts. Ground kiln.
20. Breathing smoke and fumes is dangerous to your health.
21. Wear goggles when looking through peephole.
22. Use only Orton small or Orton bar cones in the kiln sitter®.
23. When firing objects to be used with food and drink, use only supplies tested and labeled "safe" for such purposes.
24. Never use Bell bar cones or Orton large cones in the kiln sitter® ! Remove firing gauge and adjust kiln sitter® before operating.

Please Read All Instructions Before Operating Kiln.



NOTICE

The information contained in this guide is subject to change without notice.

Cress Manufacturing Company, Inc. shall not be liable for technical or editorial omissions made herein; nor for incidental or consequential damages resulting from the furnishing, performance, or use of this material.

This guide contains information protected by copyright. No part of this guide may be photographed or reproduced in any form without prior written consent from Cress Manufacturing Company, Inc.

Copyright 1987 by Cress Manufacturing Company, Inc. Firemate® is a Registered Trademark of Cress Manufacturing Company, Inc. TurboFire™ is a trademark of Cress Manufacturing Company, Inc. Kiln Sitter® is a registered trademark of W.P. Dawson Co.

UNPACK SHIPMENT IMMEDIATELY

When this shipment was given to the carrier, neither the crating nor contents were damaged. In case of damage or loss (either obvious or concealed) save all packing material. Concealed damage or loss discovered by the consignee, which was not noted at time of delivery, must be reported to the delivering carrier immediately upon discovery. At that time, an inspection of the merchandise by the carrier's representative should be requested. Failure to report such a damage or loss within 15 days places the burden of proof upon the claimant to show this damage or loss was caused while in the carrier's possession.



UNPACKING INSTRUCTIONS

IMPORTANT . . . READ CAREFULLY

Our limited warranty covers manufacturing defects only. Call us if a freight problem occurs so we may help. 1-818-443-3081.

1. OPEN BOX



2. CHECK FOR DAMAGE.

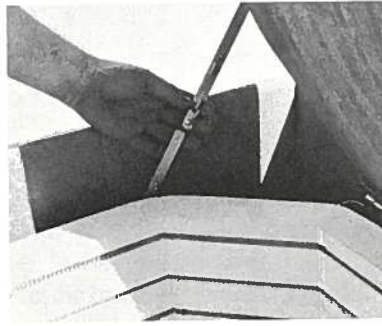

3. REMOVE STAPLES.



4. LIFT OFF BOX.



5. SET UP STAND.

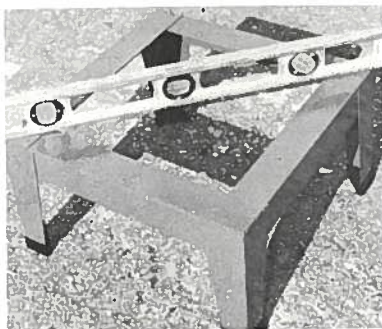

6. LIFT KILN ONTO STAND WITH HANDLES ONLY. Kiln has sharp bottom edges; do not lift there.





KILN INSTALLATION

PLACEMENT

All kilns should be located in an area free from flammable materials such as drapes, boxes, paper, spray cans, paint, gasoline, etc. All kilns must be located a minimum of 18 inches from every vertical surface. Do not place any kiln under any overhead obstruction such as cabinets, shelf, drapes, hanging plastic, etc., and never lean anything against your kiln. Do not store anything under your kiln; keep this area clear at all times. Do not store anything between the kiln and a wall. Keep material off the top of your kiln; do not use the lid as a shelf.

INSTALLATION

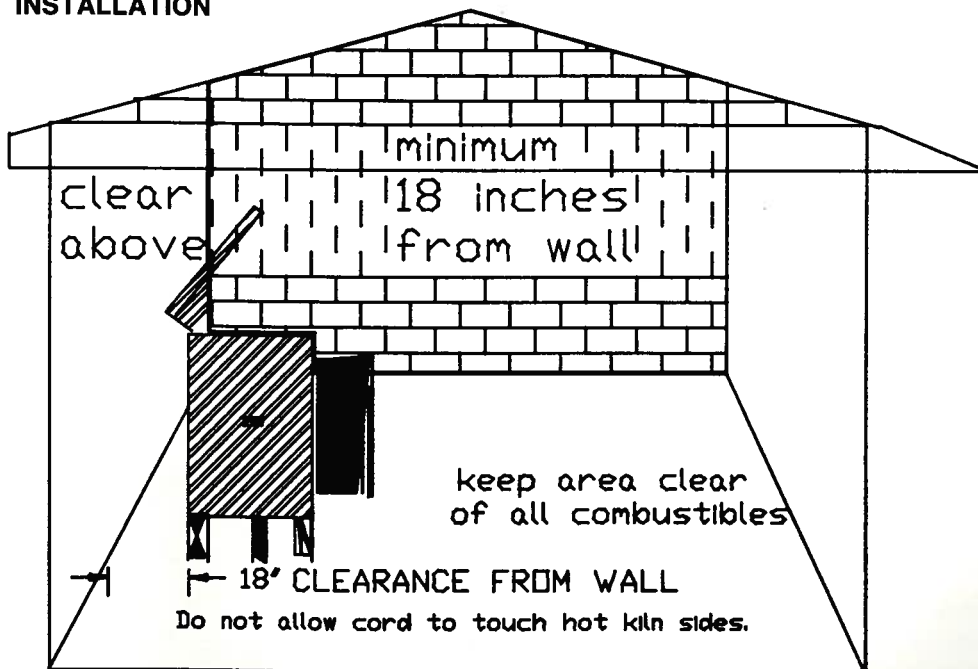

Good housekeeping must be observed at all times in the kiln area for safety.

Choose a location on a cement floor if possible. If it is necessary to put your kiln on a synthetic or wooden floor, use a sheet of fire-proof material underneath your kiln and extending 18" beyond the kiln in all directions. A layer of hard fire-brick is also acceptable for this purpose. Floor coloration may be sensitive to heat.

CEMENT FLOOR



Your kiln must be fired on the metal stand provided; it has been designed specifically for the height and weight of your kiln. Do not use any other stand. Be sure to center the kiln on the stand so that it is stable, and position it so that the cord does not touch the sides of the kiln, which will be hot during firing. It is also important that the stand and kiln be level (use a bubble level for this purpose), otherwise there is a possibility of pieces falling during firing or the Kiln Sitter® malfunctioning.

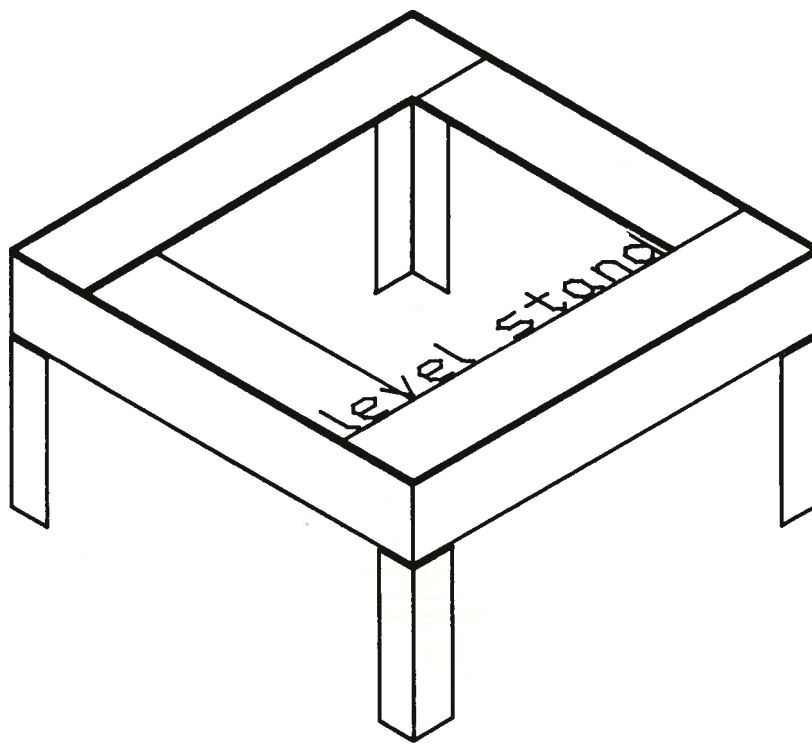
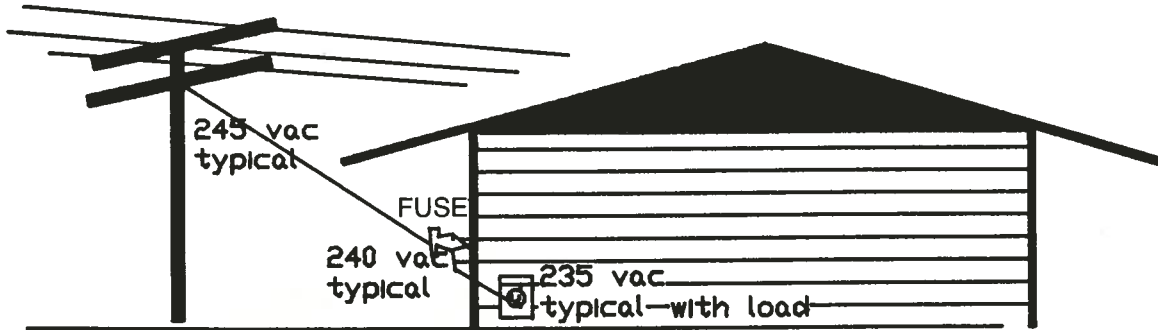

FIGURE 1-3 LEVELING STAND

Use your kiln only in a well ventilated room. Vapors containing poisonous gases are possible when firing certain materials. Do not breath fumes from kiln when firing.



ELECTRICAL SPECIFICATIONS



Proper electrical wiring is necessary to safely and efficiently operate a kiln. Even though the voltage is a full 240 volts at the meter, the voltage on which the kiln operates will be somewhat lower at the kiln location. Make sure your electrical outlet has the correct electrical capacity and voltage to handle your kiln. See electrical specification table for the requirements on your kiln. It is necessary to measure the voltage at the location of the kiln with the kiln turned on. Voltage drops occur on all wiring. Proper electrical wiring will provide an adequate operation voltage and current at the kiln without significant voltage drop. Voltage may be temporarily low during brownouts especially on a hot day in the summer when all your neighbors have their air conditioning turned on and during peak electrical usage periods in your area. If the wire coming from your power source to the kiln is too small or too long the kiln will not operate properly, even if the wire meets national electrical safety codes. If the voltage is low, the kiln may not reach the maximum desired temperature or will fire too slowly. This may reduce element life. 230 volt and 240 volt kilns may be used with 220 volt to 245 volt power.

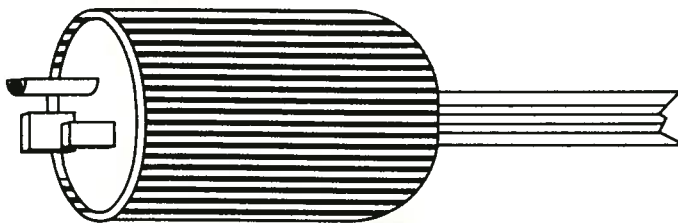

FIGURE 2-2 XL23 50 AMP CORD

Do not attempt to change the receptacle on an existing line without using the services of a licensed electrician. He will know whether the wire size is correct. It is advisable to use a larger wire size than absolutely necessary to prevent voltage drop, especially if the run to the meter is long. The increase in cost is usually very small compared to the long term savings in firing times and line loss. Never cut the plug off and replace it. If the plug becomes damaged, change the entire cord with a CRESS factory supplied cord which will meet temperature as well as electrical requirements. The outlet must be in good condition or heating of the cord and plug cap will occur. Do not use an extension cord at any time.



For your convenience, we have listed the voltage, amperage, and fuse or breaker required for your kiln.

ELECTRICAL SPECIFICATIONS

KILN MODEL	VOLTS	AMPS	KILO WATTS	SHORT RUN COPPER WIRE SIZE	RECOMMENDED FUSE SIZE	RECEPTACLE* NEMA 6-50R
XL23	240	41	9.8	6	50	50 AMP Grounded
XL23-2	208	41	8.5	6	50	50 AMP Grounded

* Wall receptacle should be located 12 - 24 inches off floor.

USE WR50 RECEPTACLE

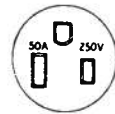



IMPORTANT

There are several items which are either necessary or are commonly used in conjunction with your kiln. These are shown on the following pages.

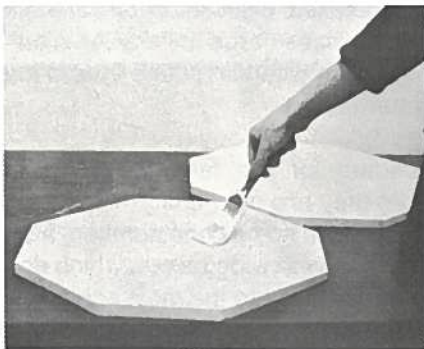

FIGURE 3-1 KILN WASH

Kiln Wash

Kiln wash is a refractory material which is used as a coating on parts of the kiln and kiln shelves to prevent ware or glazes from adhering to them. It is usually purchased as a dry powder, and then is mixed with water to the consistency of heavy cream and applied with a paint brush.

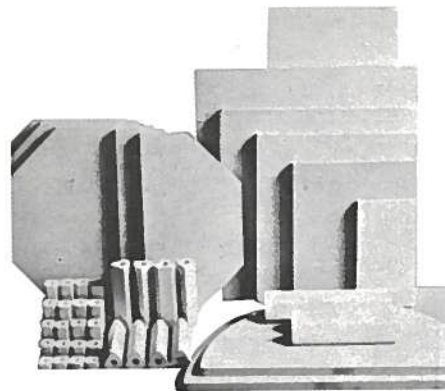

FIGURE 3-2
KILN FURNITURE

Kiln Furniture

Kiln furniture consists of shelves and posts (available in a variety of shapes and heights). They are used so that ware may be fired in several layers to take full advantage of the space in the firing chamber of the kiln. Kits containing the most commonly needed assortment of furniture for each kiln model are available.

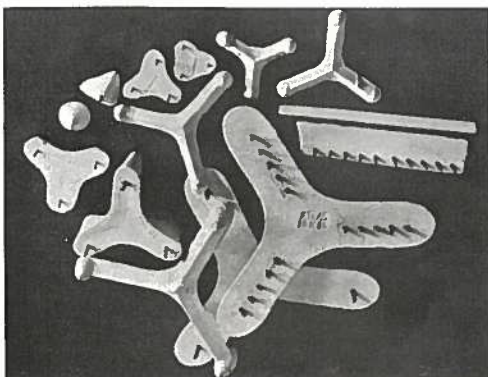
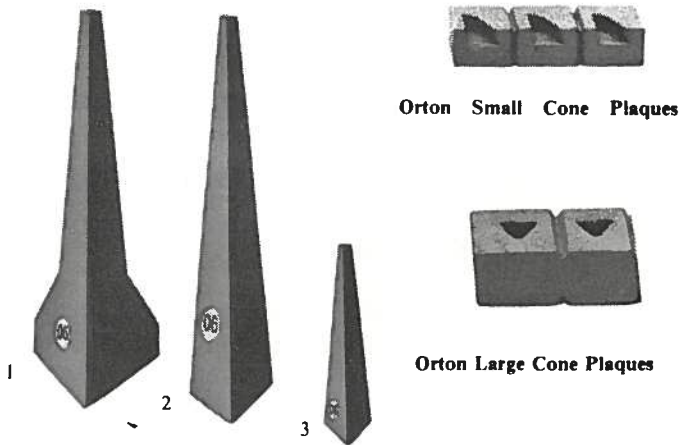

FIGURE 3-3 STILTS

Stilts

Stilts are small high temperature metal or ceramic prong supports used to raise glazed or overglazed ware off the kiln shelf to avoid sticking problems. They are available in a wide variety of shapes and sizes.



1. Orton's Self-Supporting Cones (2½"). Made in Nos. 022 through 016, 010 through 01, 1 through 3, 9 through 12 and 16 through 23.
2. Orton's Large Standard Cones (2½"). Covers the entire cone series from cone Nos. 022 through 01, and cone Nos. 1 through 42.
3. Orton's Small Regular Cones (1⅞"). Made in cone Nos. 022 through 01 and Nos. 1 through 20.

FIGURE 3-4 CONES AND HOLDERS

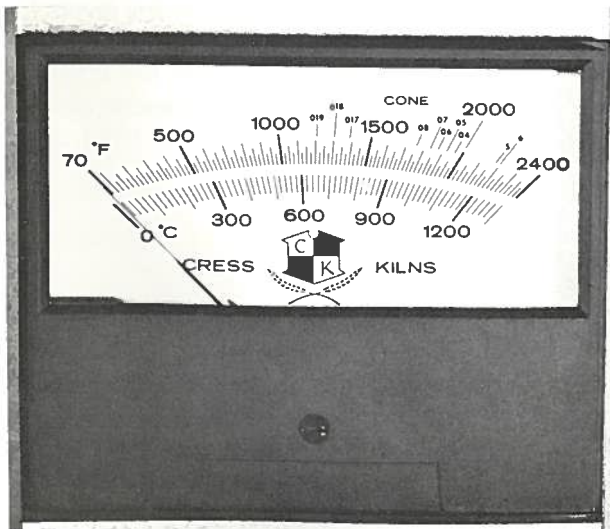

FIGURE 3-5 PYROMETER

Pyrometric Cones and Cone Holders

Pyrometric cones are the most widely used method of indicating temperature in the kiln. They are small elongated-pyramid or bar shaped indicators made of ceramic material especially formulated to melt at various specific heats (see methods of temperature indication for a more detailed discussion of cones). They are available in two sizes (large for any location in the kiln and small for use with kiln sitters®) and in a wide range of temperatures.

Various types of holders for the large cones are available to insure that they are held uniformly at the correct angle. Also available in some cone numbers are self supporting large cones with wide bases, which do not require cone holders. Cones are the most accurate heat treatment measurement method available for firing ceramics.

Pyrometers

A pyrometer consists of a temperature sensing device (thermocouple) in the kiln connected to a meter on which the temperature in the kiln is displayed. It is useful in showing how rapidly the kiln is heating and in warning when the desired temperature is neared. It is especially valuable when firing glass, which is sensitive to differences in temperature of only a few degrees. Do not use a pyrometer as a substitute for cones. A pyrometer measures only air temperature - and not the time/temperature relationship essential for firing ceramics.



KILN OPERATION

The kiln is used to apply a certain amount of heat over a period of time to a ceramic piece to produce a chemical change, resulting in a finished piece. Firing too fast causes stress to occur that can physically break the piece or stress the ceramic piece so that it breaks on its own sometime after the firing. The patented FIREMATE® control system applies the heat smoothly, (not in stepped increases) permitting faster firing without damaging the ceramic ware. The firebrick retains just enough heat so that when the cooling process starts, the bubbles from chemical gases from the vitrification process can escape the glazed surface. Rapid cooling fiber kilns can produce imperfections from trapped air in the glaze. Your ceramic pieces will achieve their best possible finish because you have the best firing equipment available. The maximum degree of heat and the length of time necessary vary widely according to many factors, such as the type of ware (porcelain, earthenware, stoneware, etc.) or glaze, paint or decal, the thickness of the piece, the size of the load being fired, and the voltage available.

FIGURE 4-1 KILN SITTER®

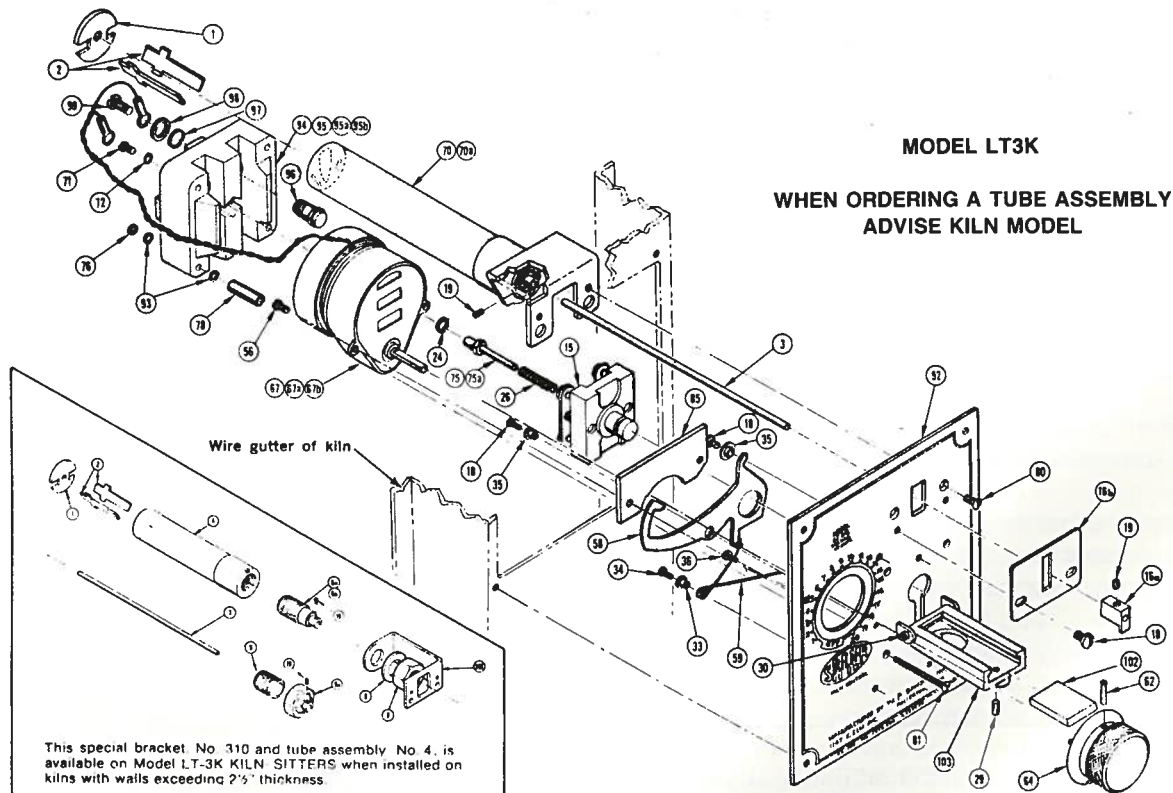



Shut-off Devices / Kiln Sitter®

CAUTION

The Kiln Sitter® control is a valuable aid when firing your kiln and is engineered to give you years of trouble-free operation when it is properly adjusted and maintained as outlined in the Kiln Sitter® operating manual. It is, however, recommended that the Kiln Sitter® not be left unattended beyond the estimated firing time. An uncontrollable accident, such as greenware falling against the end of the Kiln-Sitter® tube, may cause an overfiring which could damage your kiln. Should this occur, the operator should be in attendance to shut off the kiln manually, using the witness cones behind the peepholes as a guide.

The Kiln Sitter® should be used mainly to achieve consistent firing from one firing to the next and not as a failsafe shut off device. Note: because the small cone is placed on its side in the Kiln Sitter® with the weight of the rod pressing down on it, the small cone may bend one to two cone numbers before the witness cone. With experience, you may use one or two cone numbers higher in the Kiln Sitter® than the actual cone you wish to achieve.

IMPORTANT

Never use lubricant of any kind on the Kiln Sitter® !

The Kiln Sitter® does not take the place of watching the large cones through peepholes, but can help achieve repeatable and uniform firings. It must be kept in good working order and adjustments checked before each firing.

Before leaving the factory, every Kiln Sitter® is adjusted and its operation carefully checked. However, it is possible that the adjustments have changed in shipment or uncrating. Therefore, the following adjustments must be checked and readjusted if necessary before each firing.

WARNING

You are responsible for the adjustment and maintenance of the Kiln Sitter®. The warranty does not cover overfiring regardless of cause. The kiln will not overfire if witness cones are watched and the kiln shut off manually. Because the FIREMATE® kiln is very repeatable as compared to a manually operated kiln or most other automatic kilns, the timer should be used. The FIREMATE® kiln helps compensate for voltage fluctuations and room temperature changes, but cannot correct for load variations. Heavy loads will take longer than very light loads.

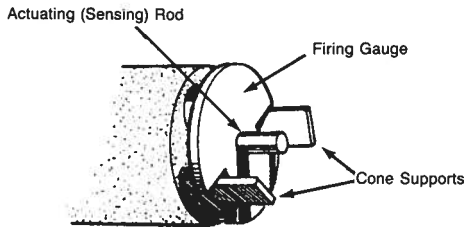

**FIGURE 4-2 INSTALL FIRING GAUGE
(For Adjustments Only)**

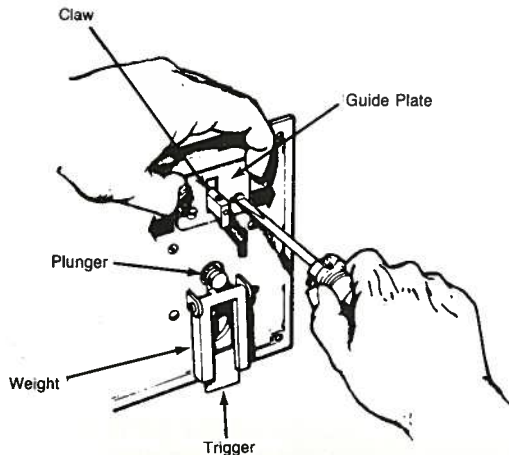

FIGURE 4-3 CENTERING GUIDE PLATE

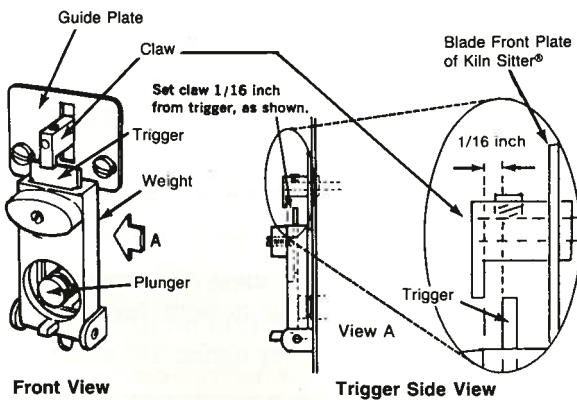

FIGURE 4-4 K/S WEIGHT CLEARANCE

Adjustments

The firing gauge is used for adjustment only, and must never be left in place on the refractory tube during firing. Remove the rubber band to release the firing gauge. Store the firing gauge for future use after you complete the Kiln Sitter® adjustments.

Check the centering of the actuating rod with the firing gauge in place.

The actuating rod must travel freely in the center of the oblong slot without touching the sides at any point, or the rod will stick and the Kiln Sitter® will fail to operate. If additional adjustment is needed, loosen two screws that hold the guide plate and move the plate to the right or left as required. Re-tighten screws and recheck its position until the actuating rod is centered. Press down on the release claw and check full travel of the actuating rod. See that it does not touch the sides of the refractory tube.

Lift the Kiln Sitter® weight to its vertical position. The release claw should just barely clear the trigger. If not, loosen the set screw in the center of the weight and slide the trigger up or down and retighten set screw securely so that it does.

Make sure all switches are off, including the timer, Kiln Sitter , and thumbwheel switch. Remove the firing gauge and store in a safe place for future adjustment checks. Raise the weight to its vertical position with one hand, with your other hand raise the actuating rod on the inside of the kiln until the claw engages the trigger. Let go of the weight and push the plunger all the way in until it locks. (limit timers must be set above the off position for this test) Slowly let the actuating rod down until the weight is released. The weight should not stick in the vertical position. It should fall freely and cause the plunger (button) to pop out into its original "off" position. Repeat several times to make sure all moving parts are free and functioning properly. Now raise the weight only 1/2 of the way up. Push in plunger and allow weight to drop. Plunger should pop out to its original position. This checks that the weight's pivot is not too tight.

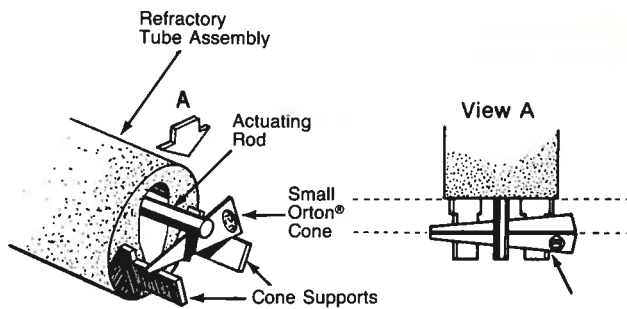

FIGURE 4-6 INSERTING SMALL CONE

Kiln Sitter® Operation

1. Check Kiln Sitter® adjustments.
2. Turn all switches to “off” position.
3. Remove firing gauge and store. Serious damage to the kiln and the Kiln Sitter® will result if the kiln is fired with its gauge in place on the refractory tube.
4. Apply a thin coat of high fire kiln wash to the top edges of the metal cone supports and the lower side of the actuating rod being careful not to apply any in the slot of the refractory tube. **Warning:** remove kiln wash from the actuating rod and cone supports and recoat with high fire kiln wash before each firing. Failure to do this will cause the cone to stick to the metal parts (when the cone softens at high heat) and will cause overfiring.
5. Lift the weight up and press down on the release claw to hold it up in position.
6. While holding the release claw down with one hand, place a small cone (1 1/8” long) under the actuating rod using your other hand. Be careful not to knock any kiln wash off the metal parts while inserting the cone. The cone should be resting with a flat side down on the cone supports.

WARNING

Keep the cone away from the refractory tube. If the cone touches the tube during firing, it will stick to it and cause overfiring.

7. When loading, keep shelves and objects at least 1/2” from the tube, cone supports, cone and actuating rod (interior of kiln), also keep the area around the kiln and Kiln Sitter® (exterior) clear of all objects. Nothing must interfere with the weight when it falls or the kiln will overfire.

8. Push plunger in so that it remains locked in. The indicator pointer on the limit timer must be above the “off” position to allow the button lock to engage.



9. FIRE WARE CHECKING LARGE PYROMETRIC CONES BEHIND PEEPHOLES. (SEE METHODS OF TEMPERATURE INDICATION) DO NOT USE KILN SITTER® AS AN AUTOMATIC SHUT OFF BUT ONLY AS AN AID TO REPEATABLE FIRING.

10. TURN TIMER “OFF” MAKING SURE THE PILOT LIGHT GOES OUT. MAKE SURE THE KILN SITTER® BUTTON POPS OUT AND TURN THE THUMBWHEEL TO “▲” AND THE SPEED CONTROL TO “MANUAL”. UNPLUG THE KILN IF THE KILN WILL NOT BE USED FOR LONG PERIODS OF TIME.



Model LT-3K

FIGURE 4-7 LIMIT TIMER

Limit Timer

The limit timer is a clock motor driven device that causes the Kiln Sitter® to shut power off to the kiln after a preset number of hours. It is not a substitute for firing with cones, but a backup to the Kiln Sitter® to help prevent severe damage to the kiln caused by Kiln Sitter® failure. The timer may be set for any period up to 20 hours and may be readjusted during firing. Of course, to be of use as a backup device, the unit must be set properly for a time great enough to fire your ware, but for a time less than required to overfire. It should be set 30 minutes longer than the estimated firing schedule. The FIREMATE® is so repeatable that the timer will have significant value as a backup device.

WARNING

We cannot extend our warranty to cover damage caused by overfiring for any reason, since we have no control on proper use of the limit timer. Do not leave any kiln unattended while firing. Watch pyrometric cones placed behind peepholes to prevent overfiring.



Limit Timer Operation

1. Use the Kiln Sitter® instructions and the following steps.
2. Set the indicator knob for the estimated time of firing plus 30 minutes. This is required before the plunger will stay locked-in.
3. The time does not start until the plunger is pushed in. It runs even when the kiln switches are turned off, if the plunger is pushed in.
4. If the timer shuts the Kiln Sitter® off before your ware is fired, the firing may be completed by lifting up the Kiln Sitter® weight, pushing in the plunger, and letting the weight down gently. You then fire manually turning all switches off when the witness cone (behind the peephole) bends.
5. Turn the timer switch to "off", and the thumbwheel switch to "▲" after every firing even if the Kiln Sitter® appears to have operated properly.

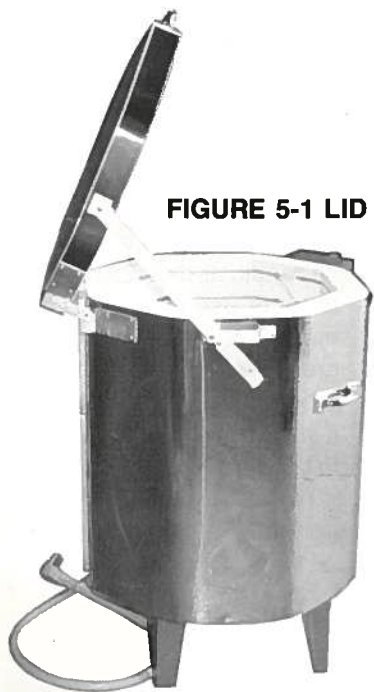

FIGURE 5-1 LID BRACE

Lid Prop

A self releasing two position lid prop is provided. The highest lid prop position is used for normal venting at the beginning of the firing cycle, providing approximately a 2" vent. The lowest lid prop position is used for the later portion of the firing cycle for china, lusters, and gold firing to obtain the best possible results. It operates simply by rotating the prop to engage the catch mounted on the lid. To release, raise the lid by the handle, causing the lid prop to swing out of the way.

Lid Brace

The lid brace locks the lid in the open position for loading and unloading. Pull lid up until the lid brace engages the slot on its arm. Then lower until lid is locked. Test by gently raising and lowering lid to make sure the lid is locked before letting it go. To unlock, gently pull the lid brace arm up while raising the lid a few inches, then lower the lid past the locking slot and gently lower the lid. Do not drop the lid, as the the firebrick is fragile.

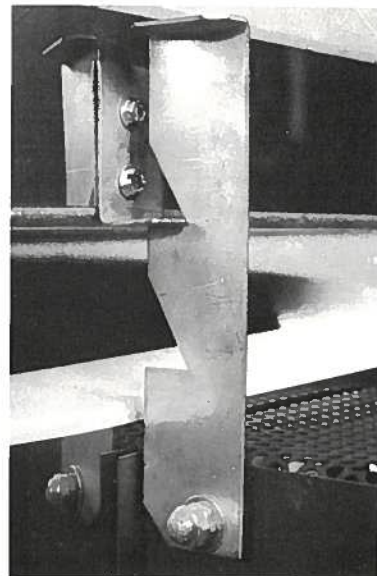

FIGURE 5-2 LID PROP



Thumbwheel Power Control Switch

Power is switched on and the amount of power flowing to your kiln is controlled by the infinitely variable thumbwheel switch. This is accomplished by cycling off and on (which causes an intermittent snapping or popping noise). When the "7" TO "10" setting is reached the switch is 100% on and no longer cycles. Viewing inside the dark panel through the top of the panel a blue light may be seen flashing as the contacts make and break. This is the same thing that happens every time you switch a light on or off in your home.

Turning the thumbwheel to higher numbers on the dial increases the power that is applied to your kiln. This percentage power control is turned automatically by the thumbwheel and motor assembly.

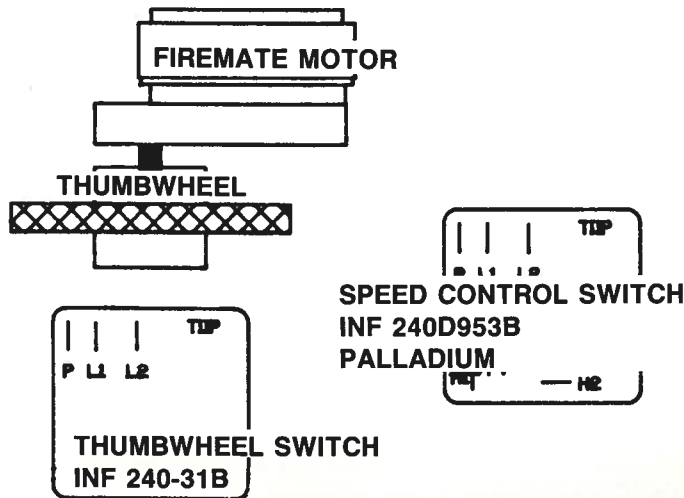

FIGURE 5-3 XL THUMBWHEEL POWER SWITCH

FIREMATE® Speed Control

This control makes the motor turn the thumbwheel at different speeds (faster or slower). It allows you to increase the rate of temperature climb and fire at precisely the speed that you want. It stops the motor when set to the "manual" setting. This allows you to manually turn the thumbwheel power control as desired.

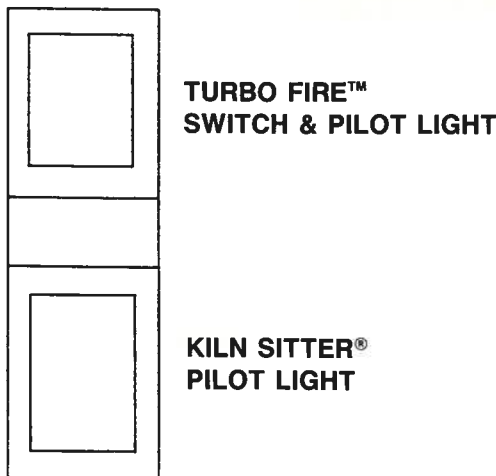

FIGURE 5-4 PILOT LIGHTS

Pilot lights

The upper pilot lighted switch indicates when the TURBO FIRE™ firing mode is turned on. Its light will cycle on and off with the normal cycling of the elements.

The lower pilot light indicates when the Kiln Sitter® is switched on providing power to the kiln.



PREPARATION FOR FIRING

- Before loading the kiln, there are several things you should do to prepare for a firing:

1.

A. Make sure timer is set to “off”.

B. Check to make sure that Kiln Sitter® button is out and therefore off.

C. Thumbwheel should be set to “ ▲ ”.

D. Do not open lid if either pilot light is on.

2. Remove all dust and chips that may have resulted from shipping (or previous firing). A small vacuum cleaner is very useful in keeping your kiln clean. Dust in the kiln could cause imperfections in glazed pieces.

3. Prepare a small amount of kiln wash. Kiln wash is a refractory material that prevents glazed pieces from sticking to shelves. It is usually purchased as a dry powder and is then mixed with water to the consistency of heavy cream. Use only high fire kiln wash. Clean all your new shelves, then kiln wash only the top side of each shelf and the floor of the kiln, applying with a paint brush. This will seal the dust and prevent glazes from adhering to these surfaces. Apply a paper thin coat, or it may chip off. When the kiln wash wears off, bare spots only should be recoated keeping the kiln wash thin but the shelves covered. If glaze has dripped onto shelves, chip it off, smooth and re-apply kiln wash to these areas. Sandpaper may be used to smooth these small areas before reapplying kiln wash. CAUTION: Do not coat the kiln sidewalls, lid or bottom of shelves. Keep kiln wash off of the elements to avoid burning out elements. Also kiln wash the top edges of the metal cone supports and the underside of the rod of the kiln sitter, being careful not to get any in the sitter tube or on any cones. Apply only a thin coat (a thick coat could cause the sitter to overfire) and apply it only to the metal parts that come in contact with the cone before and during firing.

4.

Plug in kiln, checking that cord does not touch kiln case.



LOADING

CAUTION

Make sure timer is set to "off", thumbwheel is set to " ▲ " and both pilot lights are off to prevent any possibility of electrical shock and burns from the heating elements.

The insulating firebrick used in ceramic kilns is soft and fragile. Care should be taken to avoid damaging the liner when loading (or unloading) the kiln.

Make sure that any ware you put into your kiln is bone dry (not cold to the touch). If pieces are hand molded make sure that no air pockets remain in the clay. This causes small "explosions" when fired, since the air expands and the moisture turns to steam. Hollow out the solid pieces whenever possible. Thick solid pieces can be fired safely only at very slow heating and cooling rates. Solid pieces tend to crack and break more easily during firing than hollowed pieces.

Your kiln is designed to provide as uniform a heat as possible throughout the firing chamber. The kiln should be loaded in a balanced manner; mix heavy pieces and light pieces. When firing in the same load, light and heavy ware should be alternated on the same shelf and distributed throughout the kiln to help the kiln heat evenly. This will assure that all pieces receive the same heat treatment.

Your ware will fire more evenly if you allow for sufficient air circulation around pieces. If it is necessary to place pieces on the floor of the kiln, it is recommended that you stilt them to allow for air circulation underneath. It is best to fire with a shelf at least 1/2" off the floor of the kiln.

- Never place ware closer than 1/2" from the elements in the kiln. One inch is preferable. Place large, flat pieces that take up the full width of the kiln so that their edges are between element grooves. This will prevent the edges from heating up before the center of the piece, causing possible damage by cracking from uneven expansion. To prevent unstable objects from falling during firing use stilts to make sure they do not wobble. Take care that stilts will not strain rims and other delicate areas.

It is important to always place shelves so that there is at least one element groove between shelves or between a shelf and the lid. This will allow each compartment to heat evenly up to the proper temperature. KEEP SHELVES AND WARE AT LEAST 1/2" AWAY FROM ANY PART OF THE KILN SITTER. WHEN PLACING POSTS, LINE THEM UP SO THAT EACH POST IS DIRECTLY ABOVE THE POST BELOW (SEE ILLUSTRATION) TO PREVENT STRESSING AND POSSIBLE WARPING OF SHELVES. POSTS MUST RUN IN COLUMNS THROUGHOUT THE KILN.



Remember when loading to place a large (witness) cone behind each of the peepholes for each firing so that you can monitor the progress of that firing. For an accurate reading, cones should be placed 2" to 3" behind peepholes to avoid a cooling draft. Also check the operation of the Kiln Sitter® and remember to put a small cone in the Kiln Sitter® (see Kiln Sitter® operation). For more information on cones and their use, see the section on temperature indication.

There are variations in loading techniques depending upon the type of ware being fired. The following are recommendations for loading different kinds of ware.

Loading Bisque

Low fire ceramic greenware pieces will not adhere to each other when fired, therefore they may touch one another. They may be stacked and set directly on shelves without sticking. In some cases they may be nested or placed on top of one another, if the weight is evenly distributed on the piece below. Do not, however, place a heavy piece upon a small piece or the weight may cause the lower piece to warp or crack. Tile and large flat pieces should be fired flat on a shelf so they do not warp. Slow firing is required in such cases because the shelf mass effects the temperature uniformity across the flat piece. Strain on any delicate portion of a piece could result in distortion. Fire bisque items with their lids in place to assure a good fit. Remember that although low fire greenware pieces may be touching there must still be enough room for sufficient air circulation around pieces for even firing results.

Loading for glaze firing

Glaze is finely ground glass suspended in a liquid. Two glazed pieces, if allowed to touch each other will adhere to one another when the glazes melt and re-solidify. Glaze will also adhere to the kiln or kiln shelf. Therefore stilts are used when firing most glazed pieces. Stilts are small ceramic or pointed metal supports; a wide variety is available (see the kiln accessories section). In some cases a piece may be dry footed (the base left unglazed). Be sure that the glaze is not applied too heavily, or it may "run" and stick to the shelf or the bottom of the kiln.



FIGURE 7-4 LOADING GLAZE



Remember to prepare the kiln with kiln wash, as described earlier, especially when firing a glaze to prevent any glaze from permanently adhering to the kiln bottom or shelves.

Glazed pieces should not be placed closer than ½” to one another since glaze bubbles before it smooths to its final surface. Bubbles and fumes from this process will contaminate adjacent pieces if spacing is not at least ½”. We do not recommend that glazed pieces and bisque be fired in the same load, since they are normally fired at different temperatures and since this could cause discoloration. Bisque is normally fired one cone hotter than the same piece when glazed fired.

Do not stack or nest glazed pieces. Do not fire glazed pieces requiring lids with the lids in place as they will stick together permanently.

Loading Overglaze, China Paint, Lusters, and Gold

Loading for overglaze pieces is the same as for your glazed ware, except that lusters should be spaced at least 1” apart to avoid cross contamination.

Loading stoneware and porcelain

It is necessary to fire stoneware and porcelain at a much higher temperature than that used for low fire ware or glaze. At this heat the ware becomes much softer than ceramic bisque. For this reason it may stick to other pieces and so should not be stacked or nested. It will also tend to distort in shape unless the maximum temperature is accurately controlled and the piece is properly supported. Hollow greenware pillars made of the same material as the ware are often used for support so that the expansion and shrinkage of the support is the same as that of the ware. Do not support high-fire ware on ordinary stilts. Often simpler shapes are supported by a reusable “setter” shaped for a particular piece. Do not place ware closer than ¾” from the elements to avoid uneven heating and distortion of the piece.

Use high fire kiln wash. Some prefer to load stoneware onto surfaces sprinkled with silicaflour, sometimes called “flint”. Keep “flint “ away from the elements.

Loading glass

Do not fire small thin pieces of glass and large thick pieces in the same load. Glass sagging is very sensitive to variation in temperature. Load only one or two shelves; keep the bottom shelf 3” or more off the kiln floor and keep glass pieces at least 3” or more from the kiln top. Do not crowd pieces at any time. Terra cotta molds, dusted with whiting (calcium carbonate) to prevent the glass from adhering to the mold, are used in sagging sheet glass to shape. Do not use ceramic bisque molds for sagging glass.



Pyrometric Cones

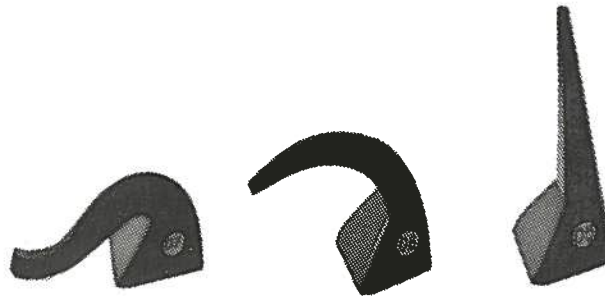
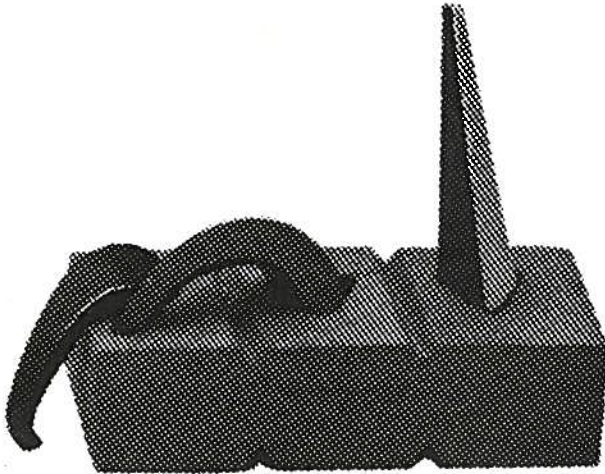

FIGURE 8-1 SELF SUPPORTING CONES

There are two basic devices for monitoring the temperature inside the kiln. The first, most essential and most widely used method is the pyrometric cone. A cone is a small elongated pyramid shaped indicator made of ceramic material which is formulated to melt when subjected to a sufficient amount of heat. It does not indicate temperature per se but the effects of temperature over a period of time. Cones react very similarly to the ceramic ware, since they are similar in composition. They deform as a result of the influence of heat, time, and kiln atmosphere, revealing what is happening in the kiln and when the proper firing temperature has been reached. There is a whole series of cones available (see cone number - temperatures chart), made to melt at different temperatures. Cones are available in two sizes. The large (witness) cones may be used at any location in the kiln to check temperature uniformity and firing progress, and the small cones or Orton bar cones are designed for use in the Kiln Sitter® (shutoff).

Always use a large cone of the number corresponding to the maximum desired temperature behind each peephole during every firing in order to monitor firing progress and check the operation of the kiln sitter®. Place the cone 2'' to 3'' behind the peephole to avoid cooling drafts and obtain an accurate indication. Do not place it too close to the elements. Be sure to position it so that you will be able to see the tip when it bends. It is important always to stand pyrometric cones at the pre-cut angle provided by the base of each cone; this should be approximately 8 degrees away from vertical in the direction the cone is expected to bend. Setting the cones consistently at this angle assures that each cone (of the same number) will bend at uniformly the same temperature. Cone plaques or wire cone holders are commercially available. Holders may also be made from brick or clay. Holders made from fire brick are generally reusable and trouble free.



An excellent way to check the temperature on any shelf in any location in the kiln is to use a cone plaque containing three large cones. One is for the desired maximum firing temperature. The other two should be numbered above and below the firing cone. These are often referred to as the guide cone, firing cone, and guard cone. The lower temperature (guide) cone bends as a warning that the desired temperature will soon be reached, the firing cone should bend until the tip is level with the base of the cone, and the guard cone, if bent too far, signals overfiring, See illustration fig. 8-3 for the proper degree of deformation.

FIGURE 8-3 GUIDE/FIRING/GUARD CONE

Small size cones are intended specifically for use with the Kiln Sitter® (automatic shutoff) mechanism (see section on Kiln Sitter® operation). It may be that there will be a slight difference in the reaction of the cone in the sitter relative to the large cone of the same number in a holder, due to the fact that the large cone is heavier, more upright, and bends under its own weight, while the small cone in the sitter is encouraged to bend slightly sooner by gravity and the weight of the Kiln Sitter® rod on top of it. If you find this to be true, it may be necessary to use a small cone one number hotter in the Kiln Sitter® than the correct large cone number to achieve the desired results. Normally if firing to cone 04 or colder you will need one cone hotter in the Kiln Sitter®. If firing to cone 5 or hotter you will normally use the same cone number. When you get to know your kiln and the typical cone reactions you will be able to achieve consistent firing results.



FIGURE 8-5 ORTON CONE PACKS

Be sure to keep pyrometric cones bone dry so that they will not crack in the kiln. Once dropped, roughly handled or exposed to moisture, cones develop small cracks which tend to make them bend prematurely and give an inaccurate temperature indication.



The cones generally used in firing clays and glazes in pottery work are numbered ranging from 07 to 04. A very common one which works satisfactorily in most cases is 06. Cones used to fire china paint, gold, lusters and decals range from 015 to 019. Cone 4, 5 & 6 are used for most porcelain. Some stoneware may be fired to cone 8. All clay and glaze manufacturers recommend the correct heat treatment for their products. Clays and glazes do vary, so check labels or ask your local ceramic supply dealer for advice on the proper cones to use, since he knows the characteristics of the clays and glazes he handles.

The Pyrometer

The second commonly used device for reading the temperature in the kiln is the pyrometer. This consists of a temperature sensing device (thermocouple) connected to a meter which indicates the temperature inside the kiln. Its principal value to the hobbyist is as monitoring device which gives warning when the maximum firing temperature is neared. It is also very valuable in working with glass, which is extremely sensitive to differences in heat of only a few degrees. In firing ceramic materials, the ideal situation is to fire with both pyrometric cones and a pyrometer, since cones reveal what is happening to the ceramic in the the kiln only at the final firing stage and the pyrometer shows the actual air temperature continually through the firing. The pyrometer does not take into account the effects of time on the firing process as does the cone.

When using a pyrometer, be sure that the meter is hung on a wall or shelf near the kiln (not on the kiln itself) away from the radiated heat of the kiln and away from drafts to obtain a more accurate reading.

Another way of gauging the approximate temperature is by the color produced by different heats. The temperature of the lowest visible red heat (observing the entire kiln atmosphere not just the elements) is 1060 °F. See a temperature-color chart for the temperatures corresponding to other colors.

Kiln Break-in:

The purpose of the first (break-in) firing is to get rid of any moisture in the kiln, to burn off the oil coating on the elements, and to test the FIREMATE® and Kiln Sitter® operation. Read all safeguards (page 2) and study directions on firing before breaking in your kiln. Fire the kiln empty to cone 019 (using the cones supplied).

On the second firing , we recommend that you fire up to cone 05 to get a good oxide coating on the elements which will help protect them. This firing should take about 5 hours; Set the timer for 5 ½ hours.

We do not recommend firing glaze in the second kiln firing. (the fumes could be hard on the unprotected elements). We also recommend that you fire with the kiln furniture in place. This will test the shelves, a very small percentage of which may crack on the first firing. (Test firing shelves is a wise precaution for any new shelves.)

Firing Ceramics

A kiln is designed to produce the extremely high temperatures necessary to chemically alter ceramic materials. It is therefore imperative that you observe all safety precautions.



Safety Cautions:

Do not leave the kiln unattended, such as firing overnight. Even though your kiln has a Kiln Sitter®, and limit timer, it is advisable to use a large cone visible through the peephole to check firing progress. Check witness cones at (1) hour intervals through firing, at the expected shutoff time and every half hour thereafter until the cone is properly bent or the Kiln Sitter® has turned off. Always check to see that the shutoff devices have operated correctly and manually turn the timer to “off” and the thumbwheel to “▲” and check that both pilot lights are out. Always monitor the progress of each firing.

Never open the lid while the kiln is firing. This could cause serious burns as well as damage to the ware. After firing always allow the kiln to cool with the lid closed until it is cool enough for you to unload it with your bare hands.

Firing Speed:

The main consideration for firing speed is that you should not fire faster than the ware will absorb heat, and you should not cool faster than the ware will release heat. Firing and cooling rapidly should be done only with test firing and thin wall ware made in ceramic molds. Hand made pieces are fired more safely in the slower firing mode. Very thick pieces, such as hand molded sculptures, require very slow heating and cooling.

Normally set the Firemate® Speed Control on normal speed “A”. Use TURBO FIRE™ for pieces made in molds, while a setting of “E” and TURBO FIRE™ mode off can be used for most handmade pieces. For very thick handmade pieces or for slow temperature soaking of these pieces or porcelain, use the manual setting for soaking, then turn the Firemate® Speed Control to normal speed “A” when you want to proceed.

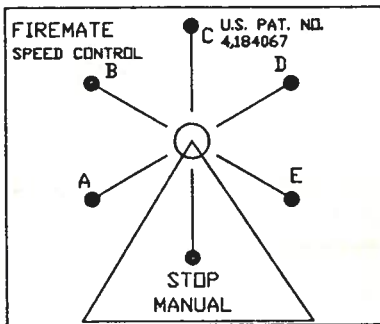

**FIGURE 8-6
SPEED CONTROL DIAL**

Remember that during firing you will not endanger your ware by turning the kiln off before maturity. If you ever hear pieces cracking or falling, or if your kiln has been jarred, turn the kiln off. Wait until it is cool, then open and check for problems that may have developed. Replace all cones with new ones before firing again.

Before Firing:

- A. Turn thumbwheel to “▲” position.
- B. Turn timer to “off” position.
- C. Raise lid and lock in place. Gently test that lid is locked in open position.
- D. When necessary, kiln wash cone supports and allow to dry.
- E. Place desired small cone in Kiln Sitter®.
- F. Load kiln. Place a large cone behind each peephole. Lower lid to closed position.
- G. Insert all peepholes except the top one.





Firing:

- STEP 1** Set timer on Kiln Sitter®.
- STEP 2** Push in plunger on Kiln Sitter®.
- STEP 3** Rotate thumbwheel to "1".
- STEP 4** Set Firemate® Speed Control as desired (usually "A" for items made in a mold or for china paint. Use "E" for handmade pieces which corresponds to the slowest automatic speed).
- STEP 5** Periodically check the large witness cone. When the large cone bends or the Kiln Sitter® turns off, manually turn thumbwheel to "▲" position and the timer to "off". Turn speed control to "stop". Allow to cool before opening.

NOTE: Use the TURBO FIRE™ mode switch to increase firing speed any time during the firing process. The switch may be turned off or on any time during the firing to speed or slow the firing process. TURBO FIRE™ is normally used from the start of all firing of ware made in ceramic molds.

The Firemate® will click on and off during its operation. This audible noise is caused by a relay lowering average power as required by the programmer. The blue-white flash which can be seen in the panel vents is caused by the relay contacts interrupting power as necessary for its proper operation. This reliable and energy efficient power reducing system has been tested at Cress for over 25 years and has proven to be extremely reliable.

Manual FX Operation:

- 1. Set speed control to "stop" or "manual."
- 2. Rotate thumbwheel to desired position.
 - "1" is low
 - "5" is medium
 - "7" to "10" is high
- 3. Use TURBO FIRE™ MODE to speed up the firing process when desired for thin walled ceramic ware or test firing. TURBO FIRE™ MODE is on when the TURBO FIRE™ switch is depressed and lighted.

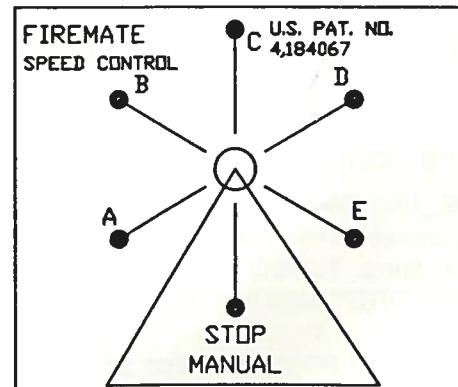

Benefits of the Firemate® With TURBO FIRE™ MODE Include:

- XL elements are all tuned for excellent temperature uniformity when used in connection with the Firemate® control.
- XL kilns are designed for cone 8 operation.
- XL kilns have built-in preprogrammed soaking: thumbwheel slows down automatically as temperature increases employing a patented feedback technique.
- XL kilns have an automatic voltage compensation circuit to help even out results when your house voltage varies during operation.
- XL kilns have a room temperature compensation circuit. For instance, cold room temperatures cause the thumbwheel to turn up slightly faster to cause the kiln heating to be constant from firing to firing.
- XL kilns have an energy and time saving firing mode made possible by the smooth firing curve achieved by the patented FIREMATE® control and the TURBO FIRE™ circuitry.



Firing Glass

Glass is very sensitive to variations in temperature of only a few degrees. We strongly recommend that you use a pyrometer to measure temperature when working with glass. Glass must be allowed to pass through the lower temperatures slowly to prevent shattering, then it may be fired rapidly up to temperature (firing rapidly at this point helps preserve colors). Glass softens quickly once the critical temperature is reached and sagging begins (usually approximately 1500°F for glass slumping); it is wise to check it often at this point (at 10 minute intervals) and when it has slumped properly, turn off all switches, crack the lid at the lower lid prop position for up to ten minutes to prevent oversoftening of the glass, then close the lid and allow to cool completely.

Glass is slumped onto terra cotta molds dusted with whiting (calcium carbonate) to prevent sticking. Be sure to read the glass loading section.

For firing glass (slumping or stretching):

- STEP 1** Set lid at lower lid prop position.
- STEP 2** Set thumbwheel to "1" and speed control to manual. Fire to 700 °F (approximately one hour.)
- STEP 3** Close lid. Turn thumbwheel to 9.
- STEP 4** Fire to approximately 1500 °F, checking at intervals for proper slumping.
- STEP 5** When proper slumping is reached, turn thumbwheel switch to "▲" and timer to "off", crack lid at the lowest lid prop position for up to ten minutes.
- STEP 6** Close lid. Allow to cool completely.

NOTE: Use TURBO FIRE™ MODE to speed up the firing process when desired for thin walled glass ware or test firing. TURBO FIRE™ mode is on when the TURBO FIRE™ switch is depressed and lighted.

The standard firing schedules given above may be varied when necessary depending upon individual circumstances. If your voltage is high and your kiln is firing too rapidly, or if you are firing an extremely thick, heavy piece and you wish to fire very slowly, you may use slower firing by leaving thumbwheel on "1" and just turning the speed control to "normal". This will allow the power to gradually increase to higher settings for a slower less heat shocking firing schedule.

Firing Charts:

It is a valuable practice to keep a written record of each firing, noting the settings (even the degree of deformation of witness cones and their locations.) This firing chart allows you to repeat good results and successful firings and avoid repeating less than satisfactory firing results.



After Firing:

After every firing, check the limit timer, there should be approximately 10 to 15 minutes left at time of kiln sitter® shut off. You should correct the timer on the next firing if there is more than 30 minutes left on the timer so that the timer works as an effective backup on the firing. Should the Kiln Sitter® fail and you forget, this could be a very important safety factor in saving the kiln and your work from destruction.

Also check the Kiln Sitter®. Observe the pilot lights (they should be off) and the position of the Kiln Sitter® weight: make sure it has fallen and has actually turned the kiln off. Correct any misadjustment problems early before damage is done to the kiln and ware. Always turn the thumbweel to "▲" and the limit timer to "off" after each firing even if the kiln sitter® appears to have functioned correctly. The Kiln Sitter® is used for added safety and for controlled firing; it is not fail proof and can not be guaranteed to turn off every time.

Always allow plenty of time for the kiln to cool (at least twice as long as it took to fire) before opening the lid. Do not unload it until you can do so with bare hands.

TURBO FIRE™ Lighted Switch:

This switch may be used at any time during the firing to turn on or off the faster energy and time saving firing mode. The light is lit when the switch is depressed indicating that the energy and time saving firing mode is on. You may push the lighted switch at any time during the firing to switch back and forth from the slow firing mode.

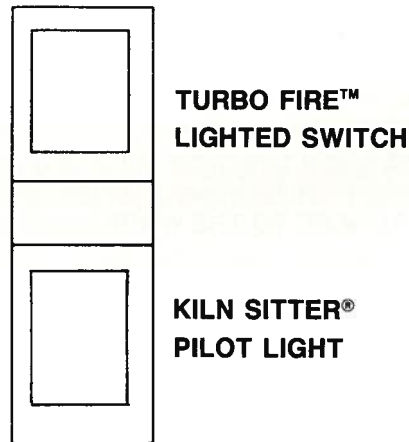



The following suggestions are general good practices to be observed for the most satisfactory results.

- Slow heating and cooling rates add quality and minimize crazing, cracking and breakage problems. Let the kiln cool at least over night then crack the lid and let pieces cool until they may be handled with bare hands. If this suggestion is not observed, you will put permanent stress in your pieces making them weaker and more subject to breaking and crazing. Use the TURBO FIRE™ switch for thin walled ware and test firing.
- Watch firings closely to protect from overfiring. Firing too hot will damage fine detail and fade colors.
- Keep the inside of your kiln free from dust and chips, which cause imperfections in pieces. A vacuum cleaner is useful in this regard.
- Always fire only bone dry ware.
- A cone plaque containing three cones (guide cone, firing cone, and guard cone- see temperature indication) is often useful as a monitoring and warning device. Always place witness cones uniformly at an 8 degree angle from vertical.

Recognizing Firing Faults

BLOTCHY BISQUE is likely to be caused by stacking too compactly, not allowing for sufficient air circulation during firing which results in uneven firing. Try loading more loosely and refiring.

WARPED BISQUE may be due to one the the following causes:

- Overfiring.
- Placing ware too close to the elements.
- Stressing delicate area by improper support.
- Removing ware incorrectly from the mold.

FAILURE OF GLAZE OR UNDERGLAZE TO ADHERE TO THE WARE (crawling glaze) can be attributed to one of the following causes:

- Dirty bisque surface. Dust and skin oil are the most common offenders. Try to clean, recover and refire the ware.
- Damp bisque. Allow to dry completely, then reapply and refire.
- Underfired or overfired bisque. If underfired, refire to proper cone, then reapply glaze and refire. Overfired bisque becomes too hard to absorb the glaze media.
- Too thick a coating of underglaze.
- Incompatibility of glaze and/or underglaze and ware. Your ceramic supply dealer can best advise you on clays and glazes that are compatible (expand and shrink at the same rate and do not chemically ruin each other.)

PUDDLING AND RIPPLING of glazes is caused by applying an excessively thick coating of glaze. If this effect is not desired, merely coat pieces more lightly on future ware.

DROPPING GLAZES on vertical surfaces is caused by overfiring glaze and by excessive glaze thickness.

SHINY SURFACE ON A MAT OR TEXTURED GLAZE can be attributed to overfiring. Also textured glazes are often applied too thinly. If this is the case. reapply and refire to the proper cone.



CLOUDY APPEARANCE can be caused by dirty brushes, or by too heavy an application of glaze.

DISCOLORED GLAZES are often caused by one of the following reasons:

- Contamination of glaze by chemicals in the ware.
- Dirty brushes.
- Loading pieces too closely, causing cross contamination of glazes by fumes or bubbles.
- Placing pieces very close to the kiln elements, creating hot bands across the piece due to direct radiation from the elements. This can leave a band of slightly faded glaze across the piece.
- Overfiring. Too high a heat will frequently cause colors to fade.
- Glazes applied directly to the greenware.
- Incompatibility of colors.

PINHOLES, BUBBLED GLAZE AND CRATERS may be attributed to one of several causes:

- Immature bisque. If your bisque is not fired hot enough to complete the vitrification and remove all vapors from chemical reactions that come from the ware, they may erupt into the glaze.
- Dust on the ware or in the kiln.
- Firing too rapidly.
- Cooling too rapidly. Craters are sometimes formed by cooling the ware too rapidly, which freezes the crater formed when the glaze bubbles. You can try merely refiring to minimize the effect of these defects, or you may apply a thin coat of glaze and refire to the proper cone which may correct the problem.

FADED DECALS are usually due to under or over firing. Check the manufacturers' recommendations and refire underfired ware to the proper cone.

TROUBLE WITH REDS is common as they are quite sensitive and often appear faded or contain washed out areas or dark spots. Probable causes and corrective measures (where possible) are listed below.

- Too thin a coating of the red glaze. Try reapplying a thicker coat and refiring.
- Overfiring. Reds are generally fired to a temperature ranging from cone 07 to cone 06. They do not do well at greater heats.
- Incompatibility with other colors. Some colors (such as green and yellow) due to chemical composition tend to make achievement of bright reds difficult. If you suspect this problem, ask your ceramic supply dealer which glazes may be used with his reds.
- Insufficient air circulation during firing. This usually results in black spots. Reds need sufficient oxygen to mature. Try leaving peephole plugs out until true red (no pun intended) heat has been reached.
- Soaking too long at maximum temperature.

CRACKING AND CRAZING (crazing is characterized by many very fine cracks running throughout the glaze surface) may be caused by one or more of the following reasons:

- Entrapped moisture. Make sure greenware or bisque is bone dry before firing.
- Internal stress due to rough handling.
- Too rapid or uneven heating or cooling (especially in heavy, thick pieces.) If this occurs, then all of the piece does not expand or contract at the same rate, resulting in stress which is released by crazing or cracking. You can usually tell if a glaze cracked during heating or during cooling by carefully examining the crack. Smooth rounded, and/or sealed cracks indicate crazing during the heating phase & sharp angular edged or separated cracks indicate too rapid cooling (possibly a draft from opening the lid or peephole too fast). If you suspect you are firing at too fast a rate for your ware to properly absorb the heat, the following is a



useful check. Place a cone on a shelf in the middle of the load. Put a bisque bowl over it, and fire as usual. Afterward compare this cone with the witness cone you used for the firing. If it is not deformed to the same degree, you are firing too rapidly for the weight of the load.

- Incompatible clays and glazes. Check with your dealer for compatible materials. crazing may often be minimized by refiring slowly to a slightly higher temperature than that to which the ware was previously fired.

DELAYED CRAZING (crazing which does not develop immediately but may appear months after firing) is the result of internal stress, usually caused by too rapid cooling (which may seem very slow to the hobbyist). Permanent internal stress combined with a small jolt, or vibration, can crack the piece months after firing. If delayed crazing is a problem, try refiring to the proper temperature and cooling very slowly. Do not open the lid or peepholes during the cooling period.



You can protect your kiln and add many extra years to its life by using this maintenance guide.

Before each loading:

- Visually check kiln and its furniture.
- Remove glaze spots on shelves, posts, kiln bottom or kiln sidewalls.
- Clean kiln by removing chips and dust. A vacuum cleaner works well for this purpose.
- Check kiln shelves for cracks. Sand any rough spots on shelves and recoat with kiln wash. Also recoat areas where the kiln wash has worn off. Avoid thick kiln wash layers. There is no need to kiln wash shelves every time you fire.
- Kiln wash floor where it has worn thin. This may not be required every firing. Sand rough spots, recoat. Keep a smooth layer not over 1/16" thick. Kiln wash built up to a thick layer may damage kiln floor by pitting due to differential thermal expansion.

WARNING

Whenever possible, use a clean kiln-washed shelf on the kiln floor to protect it.

- Check Kiln Sitter® :
- Test condition of the sensing rod. It must be centered in the porcelain tube and move freely in order to operate properly. During firing the pivot point may become corroded or residue from firing your ware may build up which can cause overfiring. Replace rod or remove and clean rod when necessary. Replace the rod if it becomes warped, or bent even slightly.
- Check cone supports and tube assembly. A thin layer of kiln wash must be maintained. Remove any accumulation of foreign material and recoat with kiln wash. If the cone supports are damaged either by bending or contamination by a non-removable material, replace them. Keep kiln wash off the tube assembly. If the end of the tube assembly breaks at the point which holds the cone supports, the tube assembly must be replaced to avoid erratic over and underfiring.
- Check Kiln Sitter® adjustments whenever your firing was peculiar or every 10 firings as shown in the Kiln Sitter® instruction manual. Heat, corrosion and mechanical wear cause changes in the adjustment over a period of time. Be careful!
- Keep the outside of the kiln clean. It is easier to clean before burning contaminants onto the stainless jacket. Use glass cleaner when kiln is cool.



RARELY NEEDED MAINTENANCE

Lid Brace

- Be aware of lid brace operation every time the kiln is fired. Replace lid brace if it becomes bent, or does not function perfectly. **WARNING** - Do not use kiln if lid brace is not in perfect operating condition.

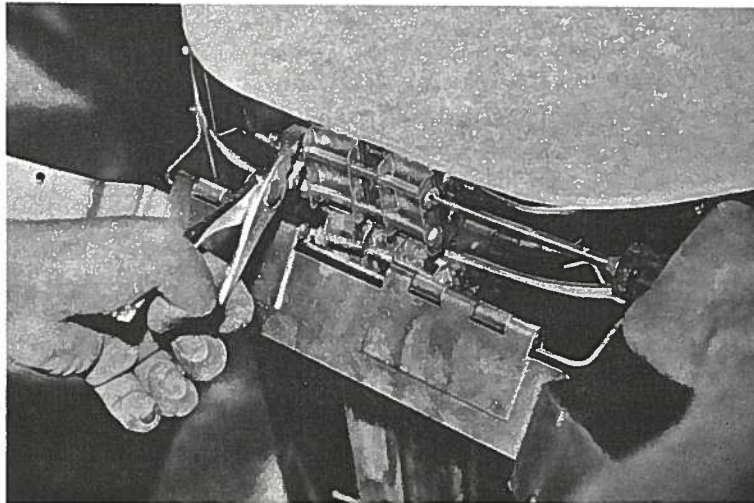

FIGURE 10-1 TIGHTENING LID BAND

Lid Band

- Tighten lid band when necessary. The normal differential expansion and contraction of the brick and lid band cause a gradual loosening of the lid band.

Stainless Steel Case

- Normally the case never needs tightening from normal use, but tighten if needed.

Pilot Lights

- Replace pilot lights if the lens becomes damaged or they fail to operate.

Cord

- Check cord every three months for heating. If cord becomes hot during firing, replace cord and wall receptacle. Check cord for heat near wall plug after the kiln has been firing for over three hours. Have a licensed electrician replace the cord with a CRESS cord and receptacle to make sure the heat specification as well as the amperage and voltage specifications are met.



TROUBLE SHOOTING

PROBLEM	PROBABLE CAUSE	SOLUTION
Thumbwheel does not turn.	Speed control switch has dirty contacts.	Flip (turn) speed control switch from fast to slow setting counterclockwise and then back to the fast setting — repeat 3 times to loosen dirt.
	Speed control switch is defective.	Replace speed control switch INF 240 D953B.
	Panel wiring is hitting against PRD11AGO relay causing relay to be stuck closed.	Push wiring away from relay.
Thumbwheel stops on 3 or 4.	Thumbwheel power switch INF240 31B is out of calibration.	Replace power switch INF 240 31B under thumbwheel if you cannot hear the switch cycling. (100% power when the thumbwheel stops at a setting of 3 or 4.) This only means the calibration of the power control is incorrect. Your kiln will still operate at a little faster speed.
		If motor is turning (check through screen and plastic window in motor) but thumbwheel is not turning up — replace motor. This is a very rare occurrence. It can be caused by breaking teeth on motor by forcing thumbwheel backwards.
Thumbwheel goes to 10 in one hour and does not stop.	Wire or element is interfering with the PRD11AGO relay operation.	Check for wire or element interfering with PRD11AGO relay. Move wires so there is no interference.
	Defective PRD11AGO relay.	Replace PRD11AGO relay.
Pilot lights do not light and kiln does not heat.	No power to kiln. Defective pilot light. Defective switch under thumbwheel. Loose connection.	Plug kiln in. Push plunger of Kiln Sitter® in. Reset circuit breaker or replace fuse. Check voltage at wall receptacle. Check kiln wiring. Disconnect all other appliances, lights, etc. on the same circuit to isolate problem. Check wall receptacle.



PROBLEM	PROBABLE CAUSE	SOLUTION
Circuit breaker or fuse blows instantly after kiln is turned on.	Short circuit.	Check with volt-ohm meter to see that you have at least 5 ohms between all prongs on kiln plug with thumbwheel set to 9. If reading is less than 5 ohms, check kiln wiring for short.
Circuit breaker or fuse blows after a while.	Defective house circuit breaker.	Check electrical specifications to see if your fuse or breaker is large enough. If not, call a qualified electrician. Do not merely install a larger fuse or breaker. Replace circuit breaker or fuse(s). Clean wire and tighten connections to circuit breaker or fuses. Do not use aluminum wiring. Use only copper wiring. Ventilate kiln room to prevent excessive heat in area with fuse box. Remove other appliances, lights, etc. from the kiln circuit. Have electrician check wall receptacle.
Kiln warms but does not reach red heat.	Incorrectly wired wall receptacle.	Green wire in kiln cord is connected to case ground. Black and white wires in kiln cord are "hot" and connected to controls. White in-house wiring is the neutral and is eventually grounded in the main house electrical panel. A qualified electrician is required for this work. Do not attempt this work yourself.
Excessive time is required to reach maximum kiln temperature.	Burned out element or worn out elements.	Check by closing lid and turning all switches to high. In three minutes, turn switch off and pull plug from electrical wall receptacle. Cautiously feel brick by each element. If one element is relatively cool, either the element is burned out or there is no power to the element. Check with ohm meter. Replace element if necessary. Operating a 240 volt kiln on 208 voltage. Call Electric Company and check your voltage.
One pilot light does not light.	Loose connection.	Replace pilot light and retighten connection.



PROBLEM	PROBABLE CAUSE	SOLUTION
Plug cap gets hot.	Corroded or worn out receptacle. Corroded cord prong. Loose or corroded cord cap connections.	Replace wall receptacle as well as the cord.
Intermittent overfiring and underfiring.	Kiln Sitter® tube assembly is defective. Cone supports are bent or dirty. End of tube assembly is broken. Tube assembly pivot points may be dirty.	Replace Kiln Sitter® cone supports or the entire tube assembly if damaged.
Kiln Sitter® plunger will not remain in.	Timer is set to "0". Strain on Kiln Sitter® face plate. Kiln Sitter® not adjusted properly, wrong cone used in kiln sitter®.	Set timer above "0". Adjust Kiln Sitter®. Set timer correctly for firing.
Kiln shuts off too soon.	Circuit breaker blows before firing is completed. Safety timer may have been set incorrectly for voltage and load conditions at time.	Replace circuit breaker if needed — check wall receptacle for voltage.
	Rarely, relay vibration may cause the plunger button to pop out prematurely.	Put shock mounts on replay studs if necessary.



Changing Thumbwheel Switch Or Motor

1. Read all instructions before starting!
2. TURN OFF POWER SUPPLY TO KILN AND UNPLUG FROM THE WALL OUTLET.

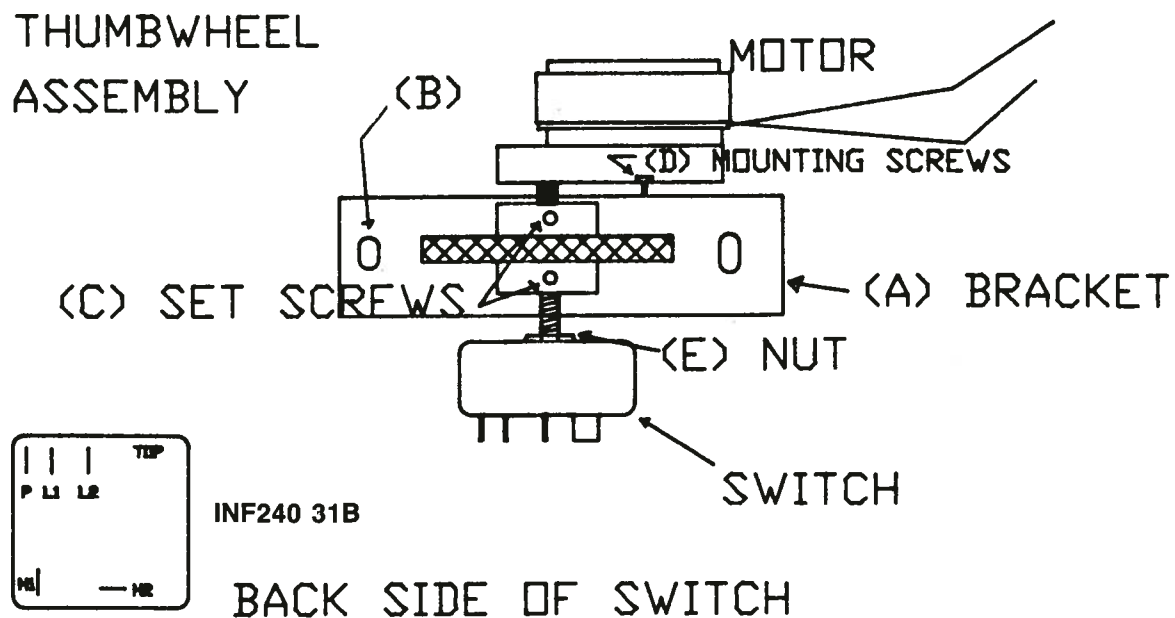

FIGURE 12-1 THUMBWHEEL ASSEMBLY

3. Remove control panel from body of the kiln by removing the 6 sheet metal screws along the edge of the panel. The panel is easier to work on if you place a small box (8" high) under it for support before unscrewing the panel. Remove firing gauge from kiln sitter® and store in a safe place. Pull the panel straight out from the kiln being careful not to damage the kiln lining with the tube assembly.

4. Notice the motor, thumbwheel, and switch that are mounted on a bracket (a) that may be removed as one unit. Remove two 6/32" nuts (b) and washers from the bracket and pull the entire thumbwheel assembly away from the panel.

NOTE: Rotate the thumbwheel so the set screws are visible (c). There are two holes in the thumbwheel, one above and one below. There are two set screws in each hole, one on top of the other (piggyback). The first set screw must be taken completely out and the second one loosened to change the defective part. You will need a 5/64" allen wrench to loosen the set screws.



Motor Removal And Installation

After completing the thumbwheel assembly removal above, remove the two mounting screws (D) from the bracket and lift the motor up and away. Install the new motor into thumbwheel making sure the flat part of the shaft is in line with the set screw hole. Tighten all screws.

220 volt kilns - Use part -620 220vac 60 cycle 3W 2/5 RPH 1136RK-1WR.

NOTE: This motor looks very similar to the Dawson Kiln Sitter®/Timer motor, but is not the same speed (RPH) and will not work satisfactorily. Make sure you have the correct motor before changing the motor. Look at the engraved information on the side of the motor to check against the specifications shown above. Reconnect blue wires from the new motor to the speed control, relay, etc.

Speed Control Switch Replacement

Loosen set screws under thumbwheel. Remove (E) 5/8" nut with a pair of needle nose pliers. Drop old switch out of the bracket leaving all wires connected. Install new switch in the reverse order making sure the flat part of the shaft of the switch is lined up with the set screw hole. Use the eraser end of a pencil to help with installation of the nut (E). With the new switch in place remove wires one by one from the old switch placing them on corresponding terminal positions on the the new switch. Rotate the thumbwheel making sure that it clicks at the 10 and "o" position. This will check that the switch is positioned on the shaft correctly. If not, start at the beginning to position the switch correctly.

5. Install the completed assembly on the control panel with the washers and nuts (B). Make sure that the thumbwheel is positioned so that it spins freely in the cut-out of the panel.

6. Replace the panel on the kiln making sure that all the wires are still connected securely and the wiring is not touching the relay and thumbwheel assembly.

Lid Replacement

1. Remove four sheet metal screws in lid brace plate.

2. Remove 8 sheet metal screws holding lid mounting bracket to lid. Remove lid.

3. Place two quarters (coins) side by side (not on top of each other) flat side down on top of kiln near lid hinge. This is the correct venting spacing required between the lid and the kiln adjacent to the lid mounting bracket. There is no space at the front of the kiln between the lid and the kiln. Place a new lid on the kiln with the handle facing opposite the hinge.

4. Screw the hinge mount to the lid. Holes are drilled using 1/8" drill. Snug down, but do not overtighten and strip the threads.

5. Reattach the lid brace plate to the lid.



6. Open and test to make sure lid brace locks properly in the full open position. Remove your quarters.

Brick bottom replacement

1. Place kiln upside down, being careful not to damage bricks in lid.
2. Loosen bolt ties at back of kiln to loosen stainless steel jacket. Do not remove bolt ties - only loosen them.
3. Remove screws that hold metal bottom cover to kiln and remove metal bottom cover.
4. Using screwdriver, pry up on the base and remove base.
5. Insert new base and metal plate.
6. Tighten bolt ties on the stainless jacket and replace all screws that secure the the metal bottom plate to the kiln.
7. Make sure all elements are reseated in element grooves. Test kiln with an ohmmeter to insure that there are no short circuits. Check Kiln Sitter® adjustments and operation before firing.

Wall Brick Replacement

NOTE ELEMENTS ARE VERY BRITTLE. If broken during repair, reorder by part number.

1. Order brick replacement by part number.
2. Remove lid and hinge mount together by removing sheet metal screws which hold the hinge mount to the top back of the kiln jacket.
3. Remove screws in bottom of the kiln jacket which screw into the metal base and brick.
4. If damaged brick is not a terminal brick (brick where element terminates into control box):
 - A) Remove bolt ties on rear of kiln jacket to release the stainless jacket.
 - B) Remove four straight element pins at the ends of the damaged brick in the element grooves by pulling straight out.
 - C) Very gently lift out brittle elements from element grooves with Kiln Sitter® screwdriver or needle nose pliers. Lift elements out just enough to release brick.
 - D) Remove damaged brick from the back side of the kiln and install a new brick. Install with element trough down. Remember that elements are brittle.



- E) Place elements into grooves and replace straight element pins.
 - F) If the brick is in the top ring, use a piece of sandpaper over a woodblock to sand the new brick down level to the adjoining bricks.
 - G) Tighten bolt ties, replace screws in hinge mount, metal base, lid brace, etc. removed for wall brick repair. See lid replacement for proper procedure for replacing lid.
 - Use quarter coin to space lid from top of kiln when replacing screws in hinge mount.
 - H) Test kiln with ohmmeter to insure no short circuits exist. Check Kiln Sitter® adjustments and operation.
6. If damaged brick is a terminal brick:
- A) Remove six screws holding control box cover to the stainless steel jacket. Pull panel carefully away careful not to put side pressure on the Kiln Sitter® tube assembly.
 - B) Unplug (element to switch) jumper wires from switch and relay(s) to release panel from wiring on kiln.
 - C) Unbolt the elements under the control box cover and straighten element wire ends so that they can be pulled through holes in brick.
 - D) Remove sheet metal screws from control panel chimney. This chimney protects the wiring the from excessive heat damage.
 - E) Remove four straight pins at the ends of the damaged brick from the element grooves.
 - F) Very gently lift out brittle elements from element grooves with long-nose pliers. Lift elements out just enough to release brick.
 - G) Remove damaged brick and install a new brick. Install with element trough down. Remember that elements are brittle.
 - H) Place elements back into grooves and replace straight pins.
 - I) If brick is in top of liner, use a piece of sandpaper over a woodblock to sand the new brick down level to the top of the adjoining bricks.
 - J) Replace bolt ties, screws, hinge mount, lid brace, etc. removed for wall brick repair.
 - K) Test the kiln with an ohmmeter to insure there are no short circuits. Check the Kiln Sitter® adjustments. Check to see that the lid brace is working properly. Replace the lid brace if not in perfect working order.



Element Replacement

1. Remove sheet metal screws in the control panel box to release the control panel box for access to element connections. Pull panel straight horizontally very gently being careful not to bump Kiln Sitter® tube on brick liner.
2. Tag and pull off “plug - on - terminal” wires which come from elements to the control box.
3. Unbolt damaged elements only from connection wires.
4. Straighten unbolted element ends.
5. Remove pins at each corner of each groove.
6. Gently lift out defective elements only and pull element ends into the interior of the kiln.
7. Install new formed elements in grooves and push element ends through holes to exterior of kiln.
8. Cut element ends so that they extend 1 ¼” out from kiln.
9. Form 3/8” loop on each element end. Loop must be snug against porcelain bushing.
10. Bolt elements back on leads as they were originally.
11. Reconnect “push-on-terminals” to control panel. See the wiring diagram in the appendix if your tagged wires did not stay tagged.
12. Replace control panel box being careful to push the control box straight in to avoid damage to the brick from the Kiln Sitter® tube. Replace screws. Do not overtighten as screws will easily strip.

THERMOCOUPLE REPLACEMENT

Your thermocouple has been marked with a minus sign (–) on the end of the large white ceramic bushing. The thermocouple lead wires must be connected with the red wire to the minus and the yellow wire to the plus side of the thermocouple.

Red to the “ – ” Yellow to the “ + ”

If you hook up the thermocouple incorrectly, your pyrometer will not operate properly. If your thermocouple is not marked, or if you believe it is incorrectly marked, you can check it with a magnet. The magnetic side is always the minus (–) and must be connected to the red wire.

After replacement of your thermocouple, we advise that you do a test fire without a load to be sure that the thermocouple is connected properly. Be careful not to hit the thermocouple when loading and unloading.

We advise that you periodically check the thermocouple visually for cracks and thinning of the tip.

Replace screws. Do not overtighten as screws will easily strip.



XL23 HEAT TREATING CHART



XL23 FIRING CHART KILN

FIRING NUMBER	DATE	CONE NUMBER	SMALL SETTER CONE ROD POSITION	LARGE WITNESS CONE			WEIGHT AND TYPE OF LOAD	SAFETY TIMER SETTING	SPEED CONTROL SETTING	TOTAL FIRING TIME		FIRING CONE APPEARANCE			EXPRESS SWITCH SETTING	REMARKS
				GUIDE	FIRING	GUARD				HRS	MIN	TOP	MID	BOT		
1			△													
2			△													
3			△													
4			△													
5			△													
6			△													
7			△													
8			△													
9			△													
10			△													
11			△													
12			△													
13			△													
14			△													
15			△													
16			△													
17			△													

FIGURE 13-1 XL23 FIRING CHART



XL23 WIRING DIAGRAM

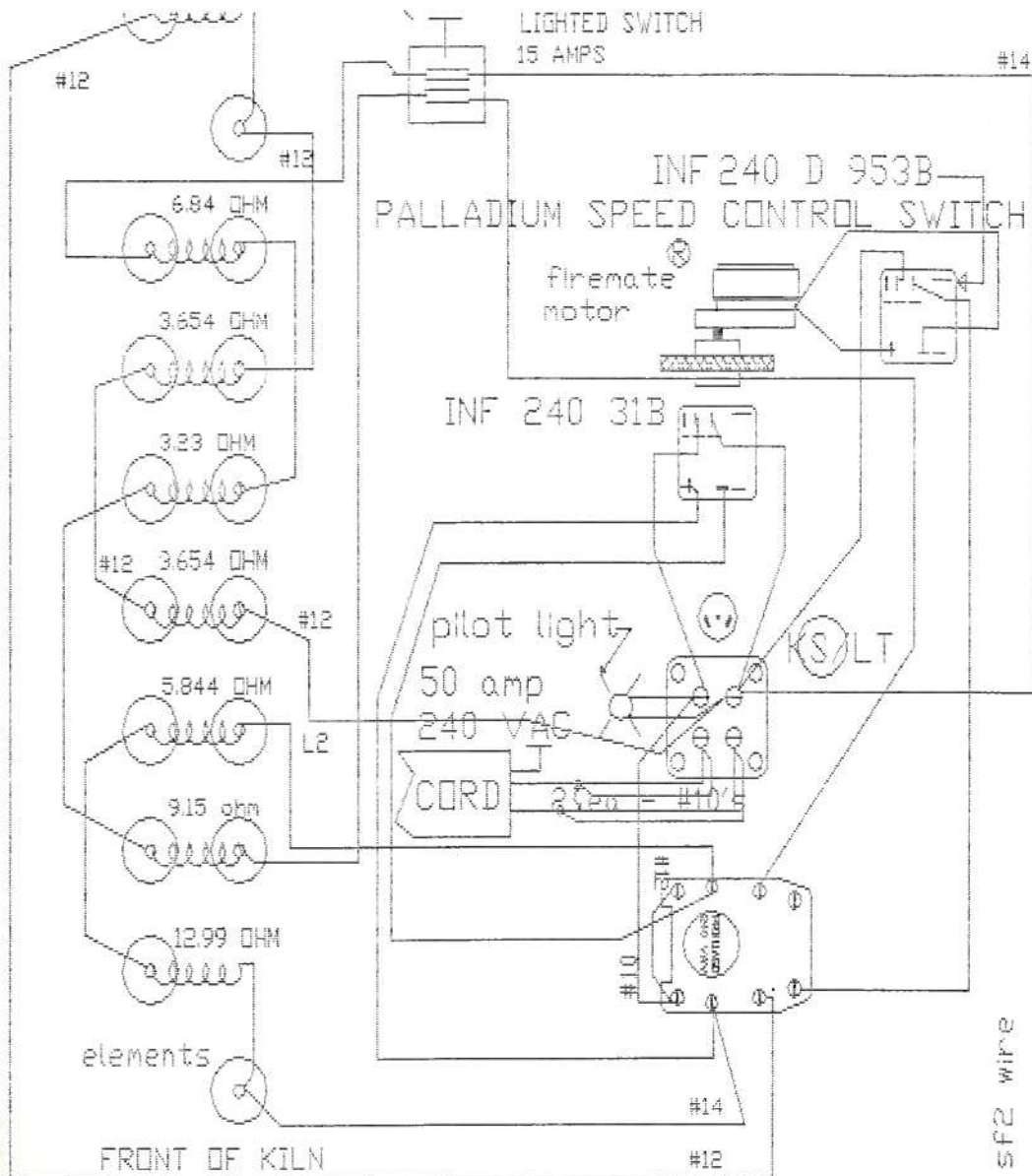

REV. 9-28-87



XL23 240 VAC 41 AMPS

FIGURE 14-1 XL23 WIRING DIAGRAM

use #14 SF2 wire



XL23 ONE YEAR WARRANTY

Limited Warranty Definitions

This one year limited warranty applies to the XL23 kiln during the one year period of this warranty.

You are the "purchaser", if you are the original purchaser of the CRESS product from either CRESS or an authorized CRESS kiln dealer. This warranty applies only to the original purchaser, and is not transferable to anyone who purchases the CRESS product from you.

The "date of purchase" is the date you originally purchased the CRESS Product, and is shown on the original authorized CRESS Kiln dealer or CRESS proof of purchase. Your sales receipt, showing the date of purchase, the CRESS Product(s) purchased, and the name of the authorized CRESS Kiln dealer that sold you the Cress product(s), serves as your proof of the date of purchase.

WARRANTY

Cress warrants to you, the purchaser, that the Cress XL23 Firemate® kiln you have purchased from an authorized Cress Kiln dealer or from Cress is free from defects in materials and workmanship for a period of one year from the date of purchase.

Remedies

During the term of this warranty, at no additional charge to the purchaser, Cress will repair or replace any defective parts of the Cress XL23 Kiln purchased under this limited warranty with new or, at the option of Cress, refurbished parts. To obtain this repair or replacement service, the purchaser must return the Cress product to an authorized Cress Kiln dealer or to Cress. The purchaser also may return the Cress product to a participating authorized Cress Kiln warranty service provider, at the service provider's option. The purchaser must prepay any shipping charges. In addition, the purchaser is responsible for insuring any product so returned and assumes the risk of loss during shipping. All parts and products replaced under this warranty become the property of CRESS.

Warranty Claim Requirements

To claim service pursuant to this warranty you, the purchaser, must:

1. Provide any authorized Cress kiln dealer, CRESS, or a participating authorized CRESS kiln warranty service provider with proof of the date of purchase from an authorized CRESS kiln dealer.
2. Return the Cress product to an authorized Cress kiln dealer, or at the service provider's option, a participating authorized CRESS kiln warranty service provider.



3. Warranty repairs are normally handled through the dealer from whom the kiln was purchased, but the purchaser may return the Cress Product to CRESS Manufacturing Company, Inc. to replace or repair defective parts. Otherwise, the purchaser may return the defective part to the Warranty Repair Department, Cress Manufacturing Company, Inc., 1718 Floradale Ave., So. El Monte, CA 91733 along with serial number, model number, voltage, proof of purchase date, and statement of what is thought to be wrong with the product. If a defect is confirmed, a new or repaired part will be shipped, postage paid by Cress Manufacturing Company. A Cress kiln may be returned for warranty work to CRESS Manufacturing Company, 1718 Floradale Ave., So. El Monte, Ca 91733. All transportation costs will be borne by the purchaser. Before shipment, the purchaser will notify CRESS Manufacturing Company either at (818) 443-3081 or 1-800-423-4584 outside California so that we may help advise in order to keep costs at a minimum, should it not be necessary to ship the entire kiln to us. Repair or replacement of defective kiln parts shall be considered as complete fulfillment of this warranty.

The purchaser must prepay any shipping charges. In addition, the purchaser is responsible for insuring any product shipped for return, because under this warranty the purchaser assumes the risk of loss during shipping.

4. The purchaser may request information on how to obtain warranty service by contacting any authorized CRESS Kiln dealer.

5. The purchaser may also request information on how to obtain warranty service by writing to the Customer Relations Department at CRESS Manufacturing Company, Inc., 1718 Floradale Ave., So. El Monte, Ca, 91733 or calling (818) 443-3081.

Disclaimer

This limited warranty does not extend to any products not manufactured by CRESS Manufacturing Company, Inc. or purchased from CRESS or an authorized CRESS kiln dealer. This limited warranty also does not extend to any products which have been damaged or rendered defective (a) as a result of accident, misuse, or abuse; (b) by the use of parts not manufactured or sold by Cress; (c) by modification, or (d) as a result of service by anyone other than CRESS, an authorized CRESS kiln dealer, or an authorized CRESS kiln warranty service provider. This warranty does not include: a kiln damaged by overfiring (exceeding the melting temperature of the material being fired) regardless of cause; a kiln damaged by transporting, abuse, improper use, reactive materials being fired (e.g. reduction, salt firing, or carbon contamination), moisture, contents other than ceramic materials, or glass being fired. Damage to ware, kiln furniture or contents of kiln are not covered. The kiln sitter[®] is manufactured and warranted by W.P. Dawson and not Cress Manufacturing Company, Inc. Cress Manufacturing Company is not responsible for consequential damage to contents being fired. Cress Manufacturing Company does not authorize any wholesaler, retailer, or employee to assume any other obligation or liabilities in regard to Cress kilns.

Except as expressly set forth above, CRESS makes no other warranty, express or implied, including, but not limited to, any implied warranty of merchantability and fitness for a particular purpose, and CRESS expressly DISCLAIMS all warranties not stated herein. In the event the product is not free from defects as warranted above, your sole remedy as the purchaser shall be repair or replacement as provided above,. Under no circumstances will CRESS be liable to the purchaser, or to any user, for any damages, including any incidental or consequential damages, expenses, lost profits, lost savings, or other damages arising out of the use or inability to use the CRESS product.

Any implied warranties are limited to the terms of this express limited warranty.



Some states do not allow the exclusion or limitation of incidental or consequential damages for consumer products, and some states do not allow limitations on how long an implied warranty lasts, so the above limitations or exclusions may not apply to you.

This warranty gives you specific legal rights, and you may also have other rights which vary from state to state.



GLOSSARY

BISQUE - Any fired undecorated clay object.

CERAMICS - A general term applying to any fired piece of clay material.

CHINA - A translucent high fire ceramic body.

CLAY - Earth that is relatively pure silica and alumina; usually a blend of different clays and minerals, combined to achieve various effects and different properties.

CONE - see pyrometric cone.

CRATERING - Imperfections in glaze caused by rapid cooling, which "freezes" bubbled glazes before they can smooth out, leaving pits.

CRAZING - A network of hairline cracks in a glazed surface which appears after firing.

DECAL, CERAMIC - A design or picture, usually overglaze, which is applied to and fired onto the ware.

DRY-FOOTING - Wiping glaze off of the base of objects before firing. This is an alternative to stiling glazed ware to keep the piece from sticking to the shelf when firing.

EARTHENWARE - Porous ware made of low fire clays.

ELEMENTS - Coils of wire having high electrical resistance and resistance to high temperatures which serve to convert electrical energy to heat in the kiln.

ENAMELING - Application of finely ground colored glass to metals (usually copper or silver) resulting in a glaze-like finish after firing.

FIREBRICK - refractory blocks used in making the insulating firing chamber of the kiln.

FIRING - Applying heat to ceramic materials to cause a change in their chemical composition (see maturity).

FIRING CHAMBER - The space in the interior of the kiln where the ware is heated.

FURNITURE, KILN - Any of a wide assortment of shelves and posts used in loading a kiln. They are used in supporting ware to take full advantage of the firing space.

GLAZE - Finely ground glass, suspended in liquid, applied to ceramic ware to give it a glossy (usually) glass-like surface when melted by firing.

GREENWARE - Any unfired clay object.

HIGH FIRE - Firing to very high temperatures; anything over cone 4. Commonly (cone 6) used with porcelain and stoneware.



KILN SITTER® - A mechanical device for shutting off the kiln at the desired temperature using pyrometric cones. It is intended for consistent controlled firing. This device does not always shut off due to operator induced mechanical variables and must be checked manually.

KILN WASH - A refractory material used as a coating to prevent sticking of ware and glazes to parts of the kiln and shelves. It is a powder which is mixed with water and applied with a brush.

LIMIT TIMER - Primarily a safety shutoff device (backup) which turns off the kiln should the kiln sitter fail. It operates strictly by time, rather than temperature and does not exclude the requirement to attend the kiln when firing. This safety device works best with the Firemate kiln because the firings are so repeatable that the set time can be set close to the expected firing time.

LOW FIRE - Ware fired only to medium temperature as for earthenware, pottery, or terra cotta.

LUSTER - An overglaze giving an iridescent finish.

MATURITY - The point at which bisque is completely fired and glazes reach the intended smooth, glassy state.

NESTING - Stacking one piece of greenware inside another, a technique used in loading for bisque firing.

OHMMETER - An electrical measuring device for measuring electrical resistance. This is used to check elements for aging or an open circuit.

OVERGLAZE - Decorative material applied on top of a glazed surface. Examples are decals, gold and other metallics, lusters, and china paints. They are always low fired (cone 018 to cone 014).

PEEPHOLE PLUG - A piece of refractory material used to close the peephole.

PINHOLES - Imperfections in a glazed surface characterized by tiny holes.

PINS - Short pieces of high temperature wire used to anchor elements in place.

PORCELAIN - A type of clay body which becomes vitreous and translucent when high fired.

POST - Columns of refractory material used to support shelves in the kiln. They are available with square, triangular or circular cross sections and in many different heights.

PYROMETER - A high temperature thermometer consisting of a heat sensing device (thermocouple) connected to a meter readout. Especially important in working with glass. This is an excellent device to measure the progress of a firing and temperature profile of a kiln.

PYROMETRIC CONE - A small elongated pyramid of ceramic material which is formulated to soften and deform at a specific temperature plus time condition, indicating that the ware is mature and the firing complete.

SHELVES - Slab of refractory material used in the kiln to support ware being fired (see furniture).



SILICA - (SILICAFLOUR, FLINT) A mineral powder used to prevent sticking of porcelain and other high fire clays during firing.

SLIP - Liquid clay used in casting shapes with molds.

SOAKING - Heat treating objects in a kiln by keeping them at a particular temperature for a period of time.

STILTS - Small ceramic or high temperature metal prongs used to raise a piece off the kiln shelf. Used chiefly in glaze firings to prevent sticking to the kiln or shelf. Many styles are available.

STONEWARE - A ceramic body which is vitreous but not translucent when high fired. It usually contains a high percentage of grog (fired clay particles) and is usually made of native clays.

TERRA COTTA - A natural, low fire red clay.

THERMAL SHOCK - The result of putting ware through sudden changes in temperature.

THERMOCOUPLE - Two wires of different metals which are inserted into the kiln and comprise the temperature sensing part of the pyrometer. It produces a very small voltage in proportion to the difference in temperature between the tip (hot junction) of the thermocouple inside the hot kiln and the cold junction on the outside of the kiln.

UNDERGLAZE - Decorative material applied to greenware or bisque.

VENTING - Allowing air into the kiln and vapors to escape by propping the lid slightly open and sometimes opening the peepholes. Usually done only in the early stages of firing.

VITRIFY - To fully fuse ceramic material to a glass-like state so that it is nonporous and watertight without glazing.

WARE - General term for any shaped ceramic object whether or not it is in a finished state.

WARPAGE - Deformation of ware during firing, usually due to overfiring or to improper placement in the kiln.



CONE/TEMP CHART

CONE/TEMP CHART

Temperature Equivalents for Orton Standard Pyrometric Cones

Cone Number	LARGE CONES	
	60°C.	108°F.
022	576°C.	1069°F.
021	602	1116
020	625	1157
019	668	1234
018	696	1285
017	727	1341
016	764	1407
015	790	1454
014	834	1533
013	869	1596
012	866	1591
011	886	1627
010	887	1629
09	915	1679
08	945	1733
07	973	1783
06	991	1816
05	1031	1888
04	1050	1922
03	1086	1987
02	1101	2014
01	1117	2043
1	1136	2077
2	1142	2088
3	1152	2106
4	1168	2134
5	1177	2151
6	1201	2194
7	1215	2219
8	1236	2257

NOTE:

For reproducible results, care should be taken to insure that the cones are set in a plaque with the bending face at the correct angle of 8° from the vertical, with the cone tips at the correct height above the top of the plaque. (Large Cone 2").



