

## 2. CVTF

### A: INSPECTION

Check for leakage of CVTF from transmission.

### B: ADJUSTMENT

#### CAUTION:

- CVTF level changes along with CVTF temperature. When inspecting CVTF level, observe the specified CVTF temperature.

- Always use specified CVTF. Using other fluid will cause malfunction.

1) Perform “Engine only Drive Mode” using the Subaru Select Monitor. <Ref. to HEV(diag)-71, HYBRID POWERTRAIN CONTROL SYSTEM, OPERATION, System Operation Check Mode.>

2) Idle the engine to raise CVTF temperature to 35 — 45°C (95 — 113°F) on Subaru Select Monitor.

3) Operate the select lever in P → R → N → D and D → N → R → P to circulate CVTF with the engine idling.

4) While the select lever is in “P” range and the engine is running, lift up the vehicle and remove the filler plug.

#### CAUTION:

Pay special attention to the following operations as the engine is at idle.

#### NOTE:

CVTF is at the specified level when it is up to the filler plug hole lower section.

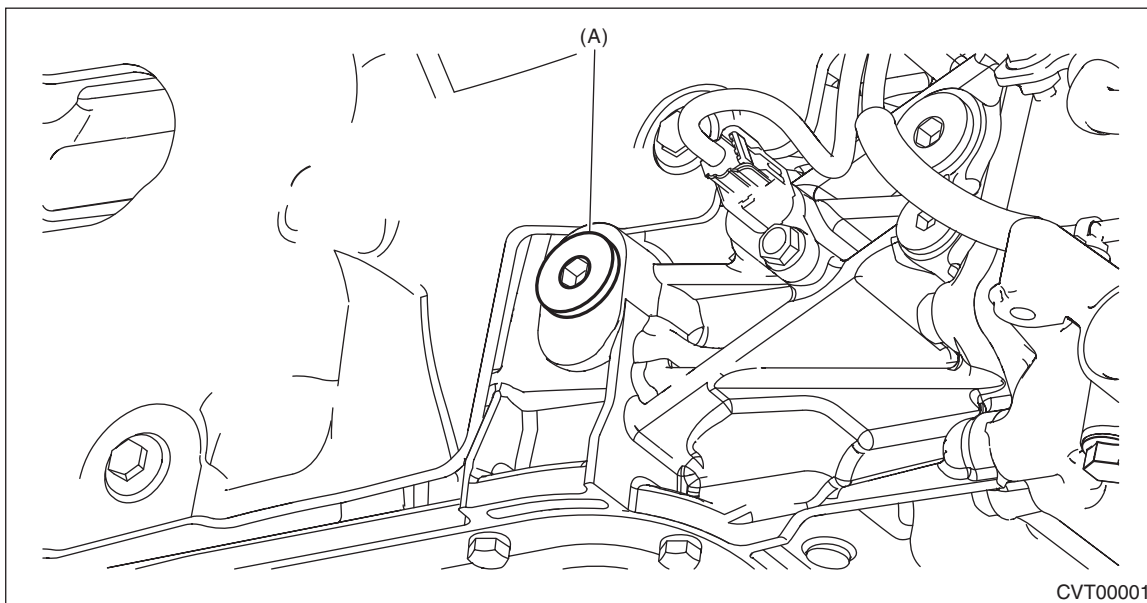

CVT00001

(A) Filler plug

# CVTF

## CONTINUOUSLY VARIABLE TRANSMISSION

5) When there is no CVTF leakage from the transmission, add the specified fluid up to the filler plug hole lower section.

**Specified fluid:**

<Ref. to CVT(TH58A)-4, HYDRAULIC CONTROL AND LUBRICATION, SPECIFICATION, General Description.>

**CAUTION:**

Note that when CVTF is added up to the lower section of filler plug while the transmission is in cold condition, overfilling of CVTF occurs, causing the oil to spill out.

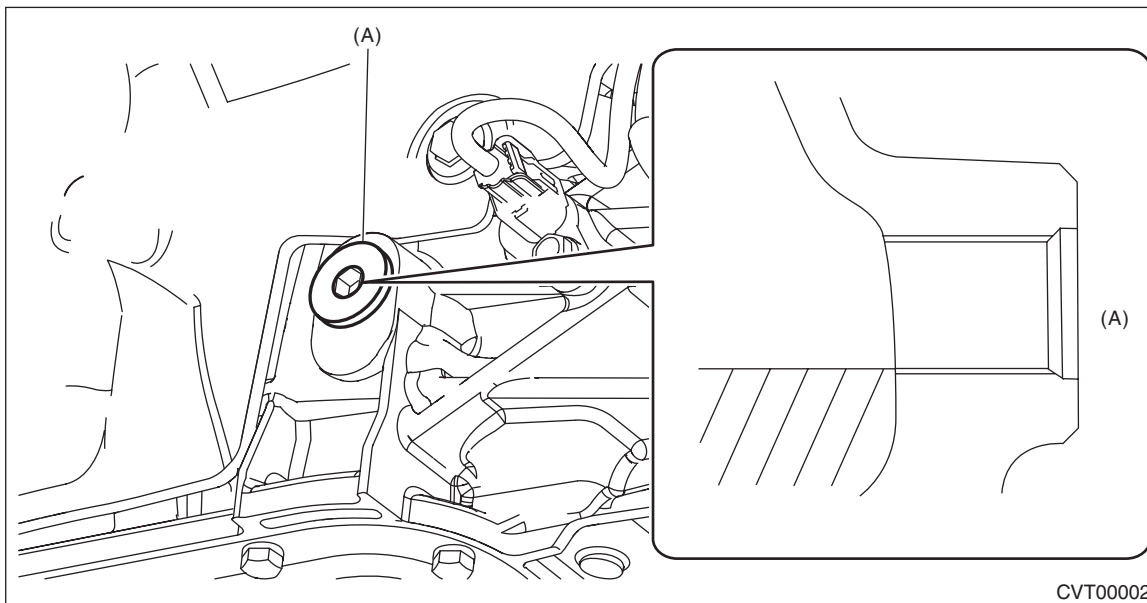

(A) Filler plug hole

6) Install the filler plug.

**NOTE:**

Use a new gasket.

**Tightening torque:**

**50 N·m (5.1 kgf-m, 36.9 ft-lb)**

## C: REPLACEMENT

### CAUTION:

- Directly after the vehicle has been running or the engine has been idling for a long time, the CVTF is hot. Be careful not to burn yourself.
- Be careful not to spill the CVTF on exhaust pipe to prevent it from emitting smoke or causing fires. If CVTF adheres, wipe it off completely.
- Always use specified CVTF. Using other fluid will cause malfunction.

- 1) Lift up the vehicle, and remove the CVTF drain plug.

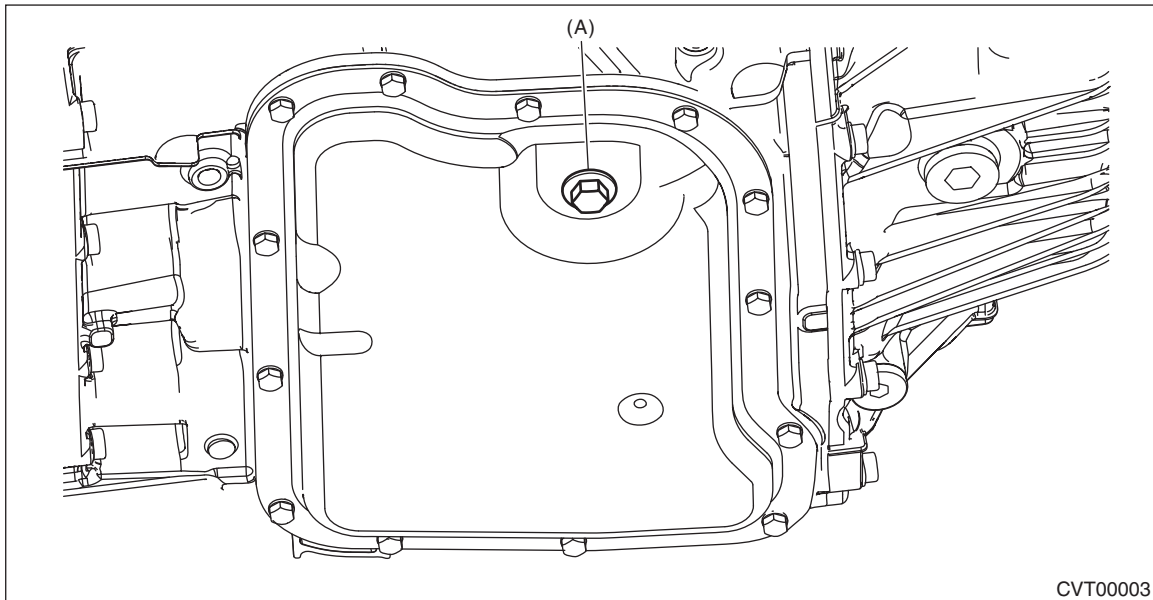

(A) CVTF drain plug

- 2) Check the CVTF condition. <Ref. to CVT(TH58A)-44, CONDITION CHECK, CVTF.>
- 3) Install the CVTF drain plug and gasket.

### NOTE:

Use a new gasket.

### **Tightening torque:**

**31 N·m (3.2 kgf·m, 22.9 ft·lb)**

# CVTF

## CONTINUOUSLY VARIABLE TRANSMISSION

4) Remove the filler plug.

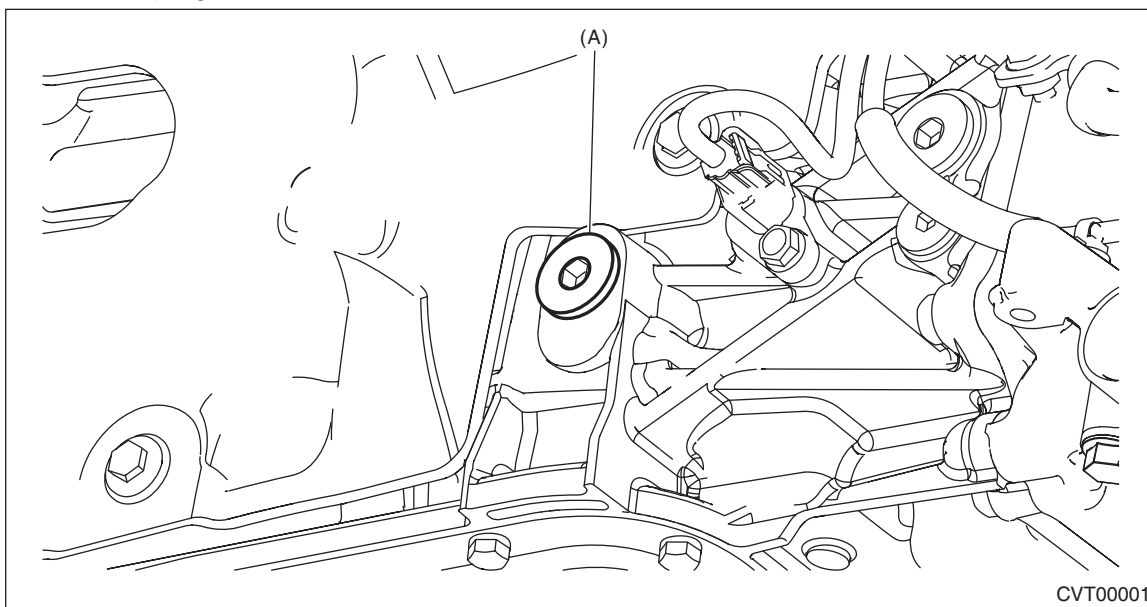

(A) Filler plug

5) Add the specified fluid up to the filler plug hole lower section.

**Specified fluid:**

**<Ref. to CVT(TH58A)-4, HYDRAULIC CONTROL AND LUBRICATION, SPECIFICATION, General Description.>**

6) Temporarily tighten the filler plug.

7) Idle the engine to raise CVTF temperature to 35 — 45°C (95 — 113°F) on Subaru Select Monitor.

8) Operate the select lever in P → R → N → D and D → N → R → P to circulate CVTF with the engine idling.

**CAUTION:**

**Pay special attention to the following operations as the engine is at idle.**

9) With the select lever shifted to “P” range and the engine started, lift up the vehicle. Adjust the CVTF level and check for leakage. <Ref. to CVT(TH58A)-41, ADJUSTMENT, CVTF.>

10) Install the filler plug.

**NOTE:**

Use a new gasket.

**Tightening torque:**

**50 N·m (5.1 kgf-m, 36.9 ft-lb)**

## D: CONDITION CHECK

**NOTE:**

When replacing CVTF, determine the condition inside the transmission body by inspecting the drained CVTF.

Fluid condition	Trouble and possible cause	Corrective action
Metal particles.	Excessive wear of the internal of the transmission body.	Replace CVTF and check if CVT operates correctly.
Thick and varnish-form fluid.	Burnt clutches	Replace CVTF and check the CVT body or vehicle for faulty.
Clouded CVTF or bubbles.	Water mixed in fluid.	Replace CVTF and check the water entering point.