

# VEHICLE DYNAMIC SUSPENSION (G426278)

DESCRIPTION AND OPERATION

Dynamic Suspension - Component Location

**NOTE:**

Right hand drive vehicle shown

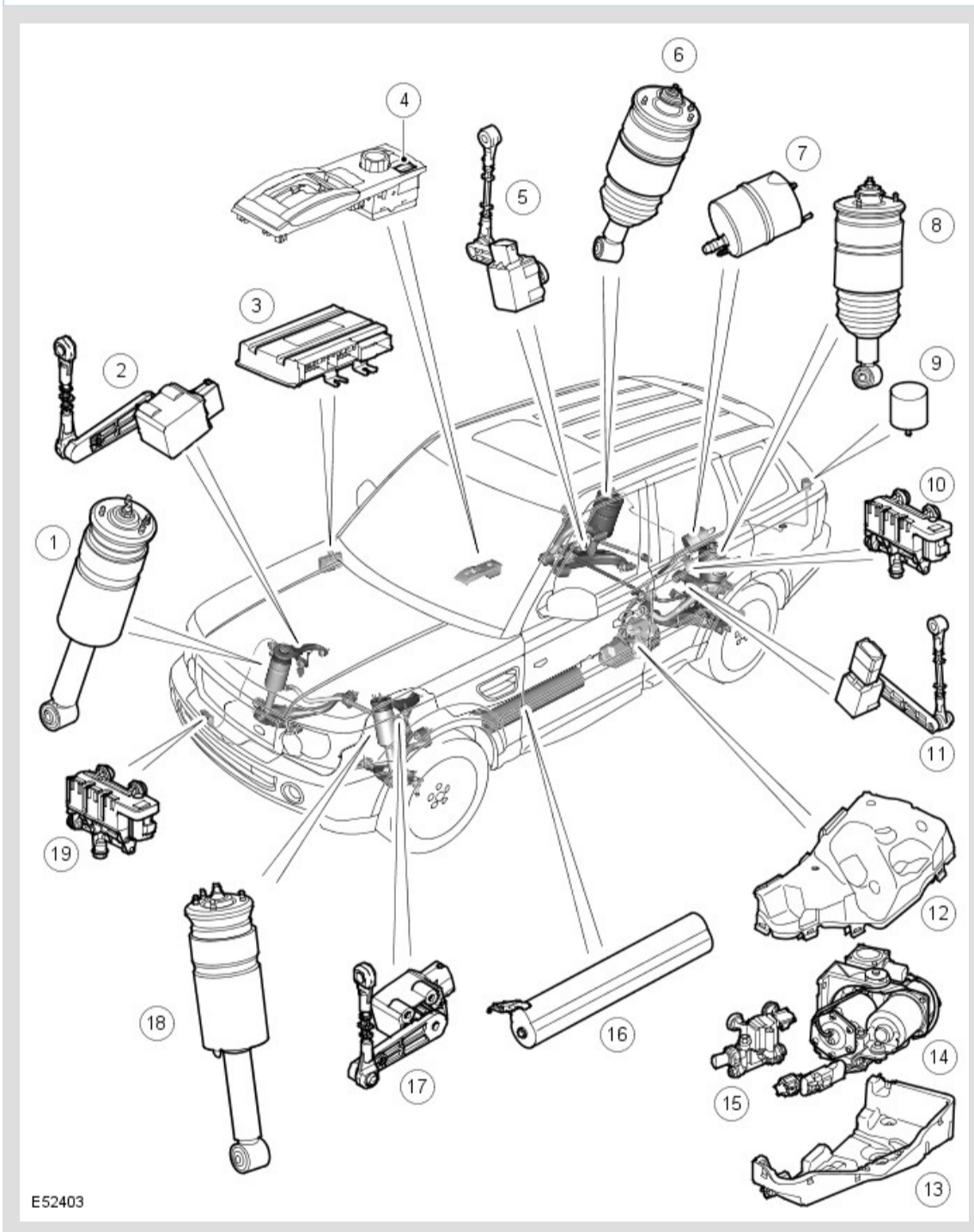

E52403

ITEM	DESCRIPTION
1	Front RH air spring damper module
2	Front RH height sensor
3	Air suspension control module
4	Air suspension control switch
5	Rear RH height sensor
6	Rear RH air spring damper module
7	Air supply unit silencer
8	Rear LH air spring damper module
9	Air filter

10	Rear valve block
11	Rear LH height sensor
12	Upper acoustic cover
13	Lower acoustic cover
14	Air supply unit
15	Reservoir valve block
16	Air reservoir
17	Front LH height sensor
18	Front LH air spring damper module
19	Front valve block

## GENERAL

### NOTE:

This section covers the air suspension control system.

Front suspension, rear suspension, Dynamic Response and Terrain Response™ are detailed in separate sections. For additional information, refer to:

Front Suspension (204-01 Front Suspension, Description and Operation),

Rear Suspension (204-02 Rear Suspension, Description and Operation),

Active Stabilization System (204-06 Ride and Handling Optimization, Description and Operation),

Ride and Handling Optimization (204-06 Ride and Handling Optimization, Description and Operation).

The dynamic suspension system is a four corner air suspension system which is fitted as standard to all models.

The dynamic suspension system is electronically controlled by an air suspension control module which controls the air supply unit, reacts to inputs from four height sensors and distributes air around the system via valve blocks.

The main air suspension system components are:

- Air suspension control module
- Air supply unit
- Four height sensors
- Three valve block assemblies
- Reservoir
- Air harness
- Four suspension air spring damper modules.

The four corner air suspension system maintains the vehicle height under all operating conditions by controlling the mass of air in the air springs. The air suspension control module uses signals from the four height sensors to maintain the correct suspension height. This is achieved by operating pneumatic control valves to increase or decrease the mass of air in the air spring damper modules.

The air suspension system has three driver selectable, pre-determined ride heights. A driver interface indicates the selected ride height and direction of movement. Additional information is also relayed to the driver via the instrument cluster message center and by audible warnings also transmitted by the instrument cluster.

Height changes can only be made when the engine is running and the driver's and passenger doors are closed.

Access height can be selected with the engine not running, within 40 seconds of moving the ignition switch to the off position provided the driver's door has not been opened in this time.

The air suspension can be controlled manually by the driver using a switch on the center console to select the required height change.

Schematic Pneumatic Circuit

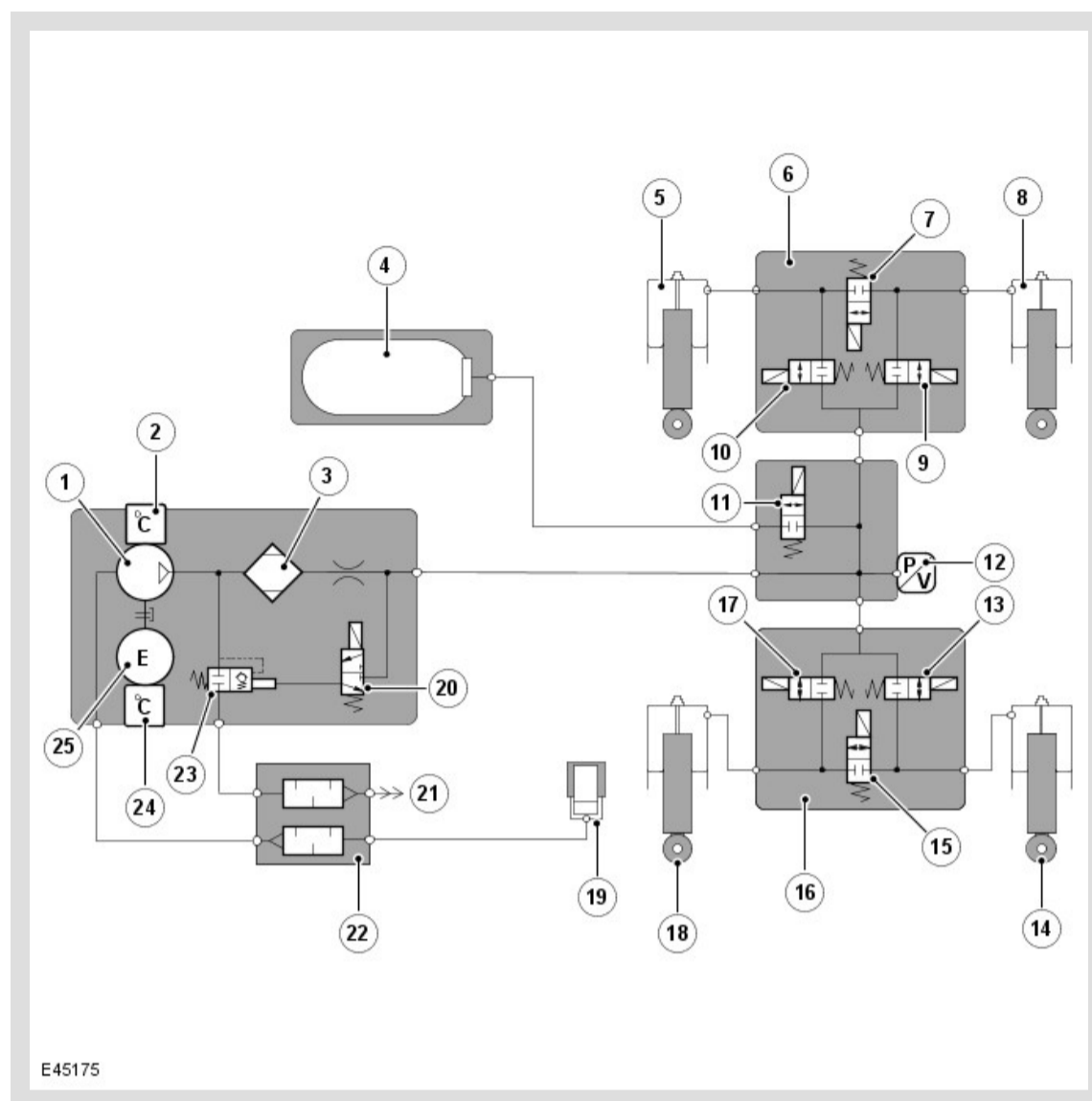

E45175

ITEM	DESCRIPTION
1	Compressor
2	Compressor temperature sensor
3	Air dryer
4	Reservoir
5	Front LH air spring damper module
6	Front valve block
7	Cross link valve
8	Front RH air spring damper module
9	Front RH corner valve
10	Front LH corner valve
11	Reservoir control valve
12	Pressure sensor
13	Rear RH corner valve
14	Rear RH air spring damper module
15	Cross link valve
16	Rear valve block
17	Rear LH corner valve
18	Rear LH air spring damper module
19	Inlet air filter
20	Pilot exhaust valve
21	Exhaust
22	Air silencer
23	Pressure relief and exhaust valve
24	Motor temperature sensor

## OPERATING MODES

The driver can manually select, using the air suspension switch, one of four ride states:

- ON-ROAD - this height is the normal operating height of the vehicle
- OFF-ROAD - this height is higher than the on-road height and provides improved ground clearance, approach, departure and breakover angles
- ACCESS - this height is lower than the on-road height and makes entering and exiting the vehicle easier for the occupants
- CRAWL (Locked at access) - this height allows the vehicle to be driven at the access height at low speeds to provide increased roof clearance in low car parks etc.

HIGH SPEED - A non-selectable, automatic high speed mode is provided which lowers the vehicle height to improve vehicle handling.

### NOTE:

Vehicle height changes are prevented if the air suspension control module receives a 'Door Open' signal from the Central Junction Box (CJB).

An additional 'TRANSPORTATION' mode is also available but is only selectable using T4.

An additional function allows the vehicle to be raised or lowered from outside of the vehicle when the vehicle is stationary. This assists with the attachment of a trailer and is achieved using the buttons on the remote handset and the ignition switch in the off position. The remote handset can be programmed to perform a number of additional functions. For additional information, refer to: Handles, Locks, Latches and Entry Systems (501-14 Handles, Locks, Latches and Entry Systems, Description and Operation).

If the air suspension control module senses that the vehicle has grounded and lost traction, the control module can temporarily increase and/or redistribute the volume of air supplied to the affected air spring(s) to maximise the available traction. This is known as extended mode and will be indicated to the driver by the lamps on the air suspension switch flashing.

If the air suspension control module senses that the vehicle is prevented from moving upwards or downwards during a height change or levelling correction, the control module will adopt a safe state and further height changes will be suspended.

If a fault is detected by the air suspension control module, the control module will reduce the system functionality dependent on the type and severity of the fault. The control module will also store a fault code which can be retrieved using T4. If a severe fault occurs, the control module will attempt to put the vehicle in a safe condition. A fault is relayed to the driver by the illumination of the air suspension warning indicator, the instrument cluster message center and an audible warning emitted from the instrument cluster.

If the detected fault is minor and does not affect vehicle safety, the air suspension warning indicator in the instrument cluster will illuminate in an amber colour and the fault should be rectified at the earliest opportunity. If a more severe fault is detected above 31 mph (50 km/h) vehicle speed, the warning indicator will illuminate in a red colour and the vehicle should be driven with care until the fault is rectified. An audible warning is emitted by the instrument cluster sounder when the warning indicator is illuminated. The indicator will change to an amber color and the audible warning will stop when the vehicle speed is reduced.

Air Suspension Switch Mode Lamps

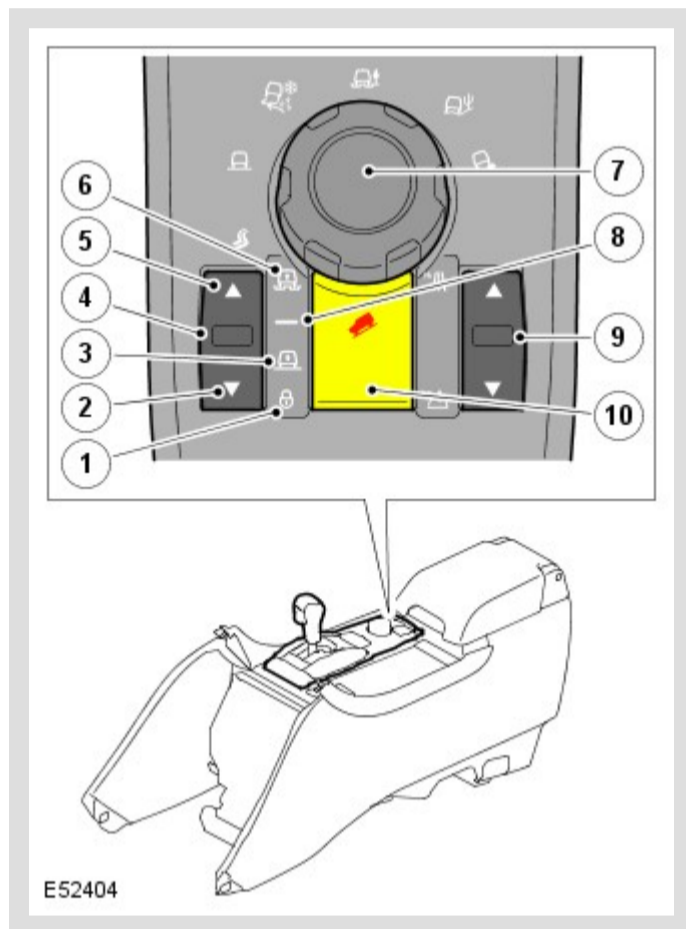

ITEM	DESCRIPTION
1	Crawl (locked at access) mode lamp
2	Lowering lamp
3	Access mode lamp
4	Air suspension switch
5	Raising lamp
6	Off-road mode lamp
7	Terrain Response™ rotary control
8	On-road (normal height) lamp
9	Transfer box range selection switch
10	Hill Descent Control (HDC) switch

#### ON-ROAD MODE

This is the normal ride height for the vehicle.

#### OFF-ROAD MODE

Off-road mode will only be activated if the vehicle speed is less than 25 mph (40 km/h). The vehicle will be raised 55 mm (2.2 in) higher than the on-road mode to provide additional body clearance and improved approach, departure and breakover angles. If the vehicle speed exceeds 31 mph (50 km/h), the air suspension control module will automatically lower the vehicle to the on-road mode height. At 25 to 28 mph (40 to 45 km/h) a message is displayed in the message center to warn the driver to slow down or the vehicle will lower.

**NOTE:**

The suspension can be automatically set to off-road mode when some Terrain Response programs and low range are selected.

## ACCESS MODE

Access mode lowers the vehicle body height by 50 mm (2 in) and provides easier entry, exit and loading of the vehicle. Access mode can be pre-selected when the vehicle is moving. The vehicle will partly lower as the vehicle speed decreases, lowering to the full access mode height when the vehicle reaches 5 mph (8 km/h). If the required road speed is not reached within a predetermined time, the air suspension will return the vehicle to the previously selected height.

Access mode can be selected at any vehicle speed. When access mode is selected, the response of the air suspension system will depend on the vehicle speed:

- If the vehicle speed is more than 12.5 mph (20 km/h), the air suspension control module will wait for up to one minute for the vehicle speed to be reduced. The access mode lamp and the lowering lamp will flash while the air suspension control module waits for the vehicle speed to be reduced, the on-road mode lamp will remain illuminated. If the vehicle speed is not reduced sufficiently, the access mode request will be cancelled after 1 minute.
- If the vehicle speed is less than 12.5 mph (20 km/h), the air suspension control module will lower the suspension to a part lowered height and will remain at this height for up to one minute. The on-road mode lamp will extinguish as the air suspension control module lowers the suspension to the part lowered height. The access mode lamp and the lowering lamp will illuminate. When part lowered is reached, the lowering lamp will flash. If the vehicle speed is not reduced to less than 5 mph (8 km/h) in the one minute period, the access mode request will be cancelled.
- If the vehicle speed is less than 5 mph (8 km/h), the suspension will be lowered to access mode immediately. The access mode lamp and the lowering lamp will illuminate. When the access mode height is reached, the lowering lamp will be extinguished.

Access height may be selected up to 40 seconds after the ignition is turned off, provided that the driver's door has not been opened within this time.

The suspension will automatically rise from access mode when the vehicle speed exceeds 6.2 mph (10 km/h). If access mode was selected directly from off-road mode then the system will return to off-road mode when the vehicle speed exceeds 6.2 mph (10 km/h). Otherwise the system will lift the suspension to On-road height.

### Selecting Access Mode Directly from Off-Road Mode

When the suspension is in off-road mode height, pressing the air suspension switch once and then a second time before the lowering lamp is extinguished, the control module will lower the suspension to access mode height. The control module will remember to return the suspension to off-road height automatically if the vehicle speed increases above 6.2 mph (10 km/h).

## CRAWL (LOCKED AT ACCESS) MODE

Crawl mode allows the vehicle to be driven at access height. The vehicle is locked in access height and can be selected at a speed of less than 21.7 mph (35 km/h) and can be driven at low speeds to improve clearance in areas with restricted headroom, i.e. car parks. If the vehicle exceeds 24.8 mph (40 km/h), crawl mode will be cancelled and the vehicle will return to on-road height.

Crawl mode allows the vehicle to be driven at low speeds with the suspension locked at the access mode height. This allows the vehicle to be driven in low car parks etc. with increased roof clearance.

Crawl mode can be selected up to 21.7 mph (35 km/h) with a long press of the switch in the down direction. The access mode lamp and the crawl mode lamp will be illuminated. When the control module is in crawl mode, on-road mode height will be selected automatically if the vehicle speed exceeds 25 mph (40 km/h). At 18.6 to 21.7 mph (30 to 35 km/h) a message is displayed in the message center to warn the driver to slow down or the vehicle will raise. Crawl mode can also be manually cancelled by moving the switch in the up direction for 1 second. The crawl mode lamp will be extinguished.

## HIGH SPEED MODE

High speed mode is a non-selectable, automatic mode which lowers the vehicle height by 20mm to improve vehicle handling. This feature is fully automated and is 'invisible' to the driver.

If the vehicle speed exceeds 100 mph (160 km/h) for more than five seconds, the air suspension control module initiates the high speed mode. When the vehicle speed reduces to less than 80 mph (130 km/h) for more than 30 seconds, the vehicle returns to the On-Road height. This function is cancelled if a trailer is connected to the trailer socket.

## AUTOMATIC HEIGHT CHANGE WARNINGS

When the suspension is in off-road mode, access mode or crawl mode height, the air suspension control module will change the suspension height automatically when the vehicle speed exceeds a predetermined threshold.

When the suspension is at off-road mode or crawl mode height, the control module issues a warning to advise the driver that the vehicle is approaching the speed threshold. The instrument cluster sounder will emit a chime, a message will be displayed in the message center and the on-road mode lamp and either the raising or lowering lamp will flash.

The off-road mode or crawl mode height speed warning is removed when the vehicle speed is reduced.

## SPECIAL MODES

### DOOR OPEN FUNCTIONALITY

If one or more of the vehicle doors are opened during a height change when the vehicle is stationary, the air suspension control module will restrict further height change. The door open signal is transmitted by the CJB on the high speed CAN bus and received by the air suspension control module. This keeps the vehicle level to the set height when a door opens to allow for changes in loading conditions.

A hardwired door status signal is also transmitted from the CJB to the air suspension control module. This signal provides door status information when the high speed CAN bus is off, i.e.; during periodic re-levelling.

The lamp on the air suspension switch for the target mode height will remain illuminated and the raising or lowering lamp will flash.

If all of the doors are closed within 90 seconds, the height change will resume. If the 90 second period is exceeded and all of the doors are not closed, the height change will be cancelled. The mode lamps showing the previously selected height and the target height will be illuminated. The mode height change can be reselected by operating the switch, however, if the vehicle is driven at speed of more than 5 mph (8 km/h) the control module will continue to raise or lower the vehicle to the target mode height.

### EXTENDED MODE

If the vehicle becomes grounded and the traction control becomes operational, the air suspension control module automatically increases the mass of air in the air springs to raise the vehicle clear of the obstruction. Extended mode is activated automatically and cannot be selected manually.

When the air suspension control module has activated the extended mode, the off-road mode lamp will flash if the suspension is above off-road mode height. The off-road mode and on-road mode lamps will flash if the suspension is between off-road mode and on-road mode heights. The on-road mode and access mode lamps will flash if the suspension is between on-road mode and access mode. A message will also be displayed in the message center.

To exit the extended mode, press the air suspension switch briefly in the up or down position or alternatively drive the vehicle at a speed of more than 3 mph (5 km/h) for 45 seconds.

### ADDITIONAL LIFT IN EXTENDED MODE

When extended mode has been invoked and the automatic lifting of the vehicle is complete, the driver can request an additional lift of the vehicle. This can be particularly useful when extended mode has been activated on soft surfaces.

The additional lift can be requested once the raising lamp has extinguished. Press and hold the air suspension switch in the up position for 3 seconds whilst simultaneously depressing the brake pedal. A chime from the instrument cluster will sound to confirm that the request has been accepted. The raising symbol will be illuminated while the vehicle is being lifted.

### SUSPENSION PREVENTED FROM MOVING

If the air suspension control module is attempting to change the suspension height and it detects that the suspension is prevented from moving, the control module will stop all suspension movement. This can be caused by jacking the vehicle, attempting to lower the vehicle onto an object or raising the vehicle against an obstruction.

The air suspension switch lamps operate as described for extended mode and the same message is displayed in the message center. To start the air suspension system operating, press the air suspension switch briefly in the up or down position or drive the vehicle at a speed of more than 12.5 mph (20 km/h).

### PERIODIC RE-LEVELLING

When the vehicle is parked, the air suspension control module 'wakes up' two hours after the ignition was last switched off and then once every six hours. The vehicle height is checked and if the vehicle is not level within a pre-set tolerance, small downwards height adjustments may be made automatically.

### TRANSPORTATION MODE

Transportation mode is a factory set mode which locks the suspension to enable the vehicle to be safely lashed to a transporter. Transportation mode can only be selected or deselected using T4.

When the ignition switch is switched off, the vehicle will be lowered onto the bump stops. This ensures that the securing straps do not become loose should air leak from the air springs.

When the engine is running, the air supply unit will operate to raise the vehicle height, allowing the vehicle to be loaded. When the ignition switch is subsequently switched off, the vehicle will again lower onto the bump stops. An audible warning will be emitted from the instrument cluster sounder until the vehicle has reached the higher transportation height.

## AIR SUSPENSION CONTROL MODULE

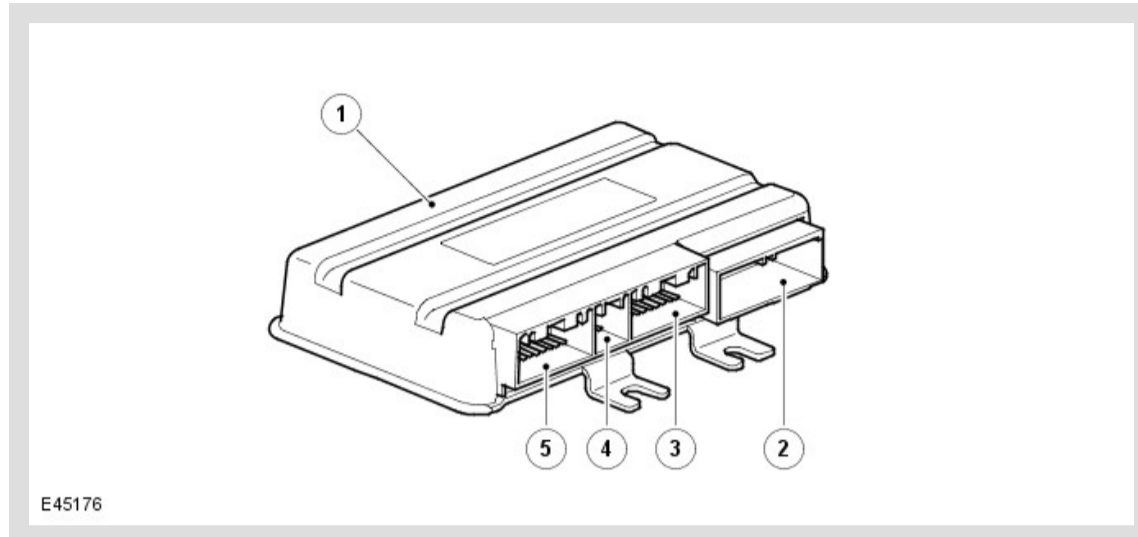

ITEM	DESCRIPTION
1	Air suspension control module
2	Connector C2321
3	Connector C2320
4	Connector C2030
5	Connector C0867

The air suspension control module is located behind the instrument panel, on the driver's side 'A' pillar. The control module is attached to the 'A' pillar with a single screw and two plastic clips.

The air suspension control module also contains the software for the variable steering. For additional information, refer to: Power Steering (211-02 Power Steering, Description and Operation).

### CALIBRATION

A calibration routine is performed using T4 to access the position of each corner of the vehicle and record the settings in the control module memory. Once set, the calibration is not required to be performed unless the air suspension control module is removed or replaced, a height sensor is removed or replaced or a suspension arm to which the sensor is connected is removed or replaced. If a removed height sensor is subsequently refitted, the calibration procedure will have to be performed to ensure the integrity of the system.

If the air supply unit, the reservoir, a valve block, a damper module or the air harness is removed or replaced, the system will not require recalibration.

### INPUTS AND OUTPUTS

The air suspension control module uses four harness connectors for all inputs and outputs.

The air suspension control module uses inputs received on the CAN bus from other vehicle systems. The system uses longitudinal acceleration, lateral acceleration, steering angle and wheel speed data to control the suspension operation in differing driving conditions.

The system will react differently if one or more of these data inputs is missing or incorrect, for example, if the steering angle sensor is missing or incorrect, the air suspension control module assumes a default value of zero which may result in some unnecessary levelling activity.

### STEERING - SERVOTRONIC VALVE

The power steering Servotronic 2 system is controlled by software which is incorporated into the air suspension control module. The software responds to steering torque inputs and road speed signals and controls the assistance via a transducer valve located on the steering gear valve. The valve is connected by two wires to the control module on connector C2320. For details refer to the Power Steering section. For additional information, refer to: Power Steering (211-02 Power Steering, Description and Operation).

### AIR SUPPLY UNIT RELAY

The air supply unit relay is located in the Battery Junction Box (BJB) in the engine compartment. The relay is connected directly to the battery via fusible link 10E (60A). The relay coil is connected to and controlled by the air suspension control module. The relay is used by the air suspension control module to control the operation of the compressor.



When air supply unit operation is required, the air suspension control module supplies power and ground for the relay coil which energises, closing the relay contacts. This allows battery voltage via the fusible link to pass through the relay and operate the air supply unit electric motor and the compressor.

The battery voltage is also passed from the relay, via a splice joint in the harness, to the air suspension control module and is used as a signal that the air supply unit is operating.

#### SYSTEM INHIBITS

A number of conditions exist where a change of ride height is undesirable. To counter this, the air suspension control module is programmed with a number of system inhibits. If any of the conditions detailed below exist, the air suspension control module will suspend height changes and height corrections.

#### Compressor

The temperature sensors located within the compressor protect the compressor from overheating. If the compressor temperature rises above set limits, the air suspension control module will inhibit the compressor operation. These limits are shown in the following table:

##### Compressor Head Temperature Sensor

	LIFTING	FILLING RESERVOIR
<b>Stop</b>	150°C (302°F)	140°C (284°F)
<b>Start</b>	130°C (266°F)	120°C (248°F)

##### Compressor Brush Temperature Sensor

	LIFTING	FILLING RESERVOIR
<b>Stop</b>	140°C (284°F)	130°C (266°F)
<b>Start</b>	120°C (248°F)	110°C (230°F)

#### Cornering

If the air suspension control module registers a cornering force greater than 0.2g it will inhibit all height changes and corrections. The system will remain inhibited until the cornering force falls to less than 0.15g. The air suspension control module receives a message from the lateral acceleration sensor (which is an integral part of the ABS yaw rate sensor) on the high speed CAN bus for the cornering force.

#### Rapid Acceleration

If the air suspension control module registers a rapid acceleration greater than 0.2g it will inhibit all height changes and corrections. The system will remain inhibited until the rapid acceleration falls to less than 0.15g. Acceleration is calculated by the air suspension control module from a vehicle speed signal received via the high speed CAN bus.

#### Rapid Deceleration

If the air suspension control module registers a rapid deceleration smaller than -0.2g it will inhibit all height changes and corrections. The system will remain inhibited until the rapid deceleration rises above -0.15g. Deceleration is calculated by the air suspension control module from a vehicle speed signal received via the high speed CAN bus.

#### Vehicle Jack

The air suspension control module will inhibit all height changes and corrections if it detects a corner lowering too slowly for more than 1.2 seconds. This is interpreted as the corner identified as moving too slowly being supported on a jack. In this situation, the corner height will not change when air is released from the air spring because the jack acts as a mechanical prop. The system will remain inhibited until any of the following conditions exist:

- The air suspension switch is moved to the up or down position
- Vehicle speed rises to more than 9.3 mph (15 km/h) for more than 15 seconds.

#### Door Open

The air suspension control module will stop all height change requests while any of the doors are open. Vehicle levelling continues with a door open by keeping the vehicle at the height when the door was opened if the vehicle load changes.

#### DIAGNOSTICS

The air suspension control module can store fault codes which can be retrieved using T4. The diagnostic information is obtained via the diagnostic socket which is located in the lower instrument panel closing panel, on the driver's side, below the steering column.

The diagnostic socket allows the exchange of information between the various control modules on the bus systems and T4 or a diagnostic tool. This allows the fast retrieval of diagnostic information and programming of certain functions using T4.

### **Fault Detection**

The air suspension control module performs fault detection and plausibility checks. Fault detection is limited to faults that the control module can directly measure as follows:

- Sensor electrical hardware faults
- Valve electrical hardware faults
- Sensor and actuator supply faults
- Bus failures
- Control module hardware errors.

Plausibility checks are checks on signal behaviour, as follows:

- Average height does not change correctly
  - Height changes too slowly
- Gallery pressure
  - Does not increase fast enough when reservoir filling requested
  - Increases when system is inactive
  - Too low when lifting is requested
  - Increases too rapidly when filling reservoir
  - Does not decrease when gallery is vented
  - Pressure varies too much when inactive.
- Compressor temperature
  - Sensor voltage too large - head and brush sensors (short circuit to battery)
  - Takes too long to be readable after suitable compressor run time - head and brush sensors
  - Does not increase when compressor active - head sensor only
- Sensor activity
  - Signal floating
  - Constant articulation when moving

When a fault is detected, the air suspension control module will attempt to maintain a comfortable ride quality and where possible will retain as much functionality as possible.

The system functionality depends on the severity of the fault.

### **Faults**

- Height sensor faults (hardware faults) and reservoir valve block failure
  - Retain full functionality with no 'refinements', e.g. cross-link valves inoperative, no compensation for uneven surfaces.
- Pressure sensor faults, compressor faults, corner valves stuck shut
  - Road speed signal not available
  - Vehicle returns to on-road mode height when next requested
  - Levels at 'current' height.
- Reservoir valve stuck open, exhaust valve stuck shut if below on-road mode height, corner valves stuck open if above on-road mode height
  - Vehicle returns to on-road mode height when next requested
  - Does not level at 'current' height.
- Failure of multiple height sensors, cross-articulation when driving, calibration corrupted
  - Vehicle lowers to bump stops.
- ABS module failure, CAN bus failure
  - If the air suspension control module loses communications with the ABS module or the ABS module reports a fault, the air suspension control module immediately returns to the 'default' height, which is below the on-road ride height. Once at the default height, the control module will continue to level the vehicle at this height. It is unlikely that the fault will be in the air suspension

control module. When the fault is repaired, the air suspension control module will resume full functionality but the error will remain in the control module memory.

For major faults the control module will not level the vehicle at the 'current' ride height. The control module freezes height changes until it receives a manual or automatic request for height change. The control module will return to standard height if possible and freezes once standard height is achieved.

If the suspension is above the on-road height and the air suspension control module cannot lower the suspension, all height changes will be frozen. The control module will issue a message on the high speed CAN bus which is received by the instrument cluster which displays a maximum advisable speed in the message center. An immediate 'freeze' of the vehicle height is caused by the following:

- Failure of more than one height sensor - vehicle on bump stops
- Implausible articulation symptoms detected - vehicle on bump stops
- Valve or solenoid failure - corner valve stuck open below on-road mode height or exhaust valve stuck shut above on-road mode height
- Stuck corner or whole vehicle (diagnosed using plausibility of the sensor inputs).

If height change is not possible, e.g. exhaust valve failed closed at off-road height or compressor failed at access height, the control module will not level or change height.

If the air suspension control module has a hardware fault, the control module will disable all air suspension functions. Detectable hardware errors include memory error, control module failure and calibration errors.

### Fault Messages

The air suspension has two methods which it can use to inform the driver of a fault in the air suspension system; the air suspension switch LED's and the instrument cluster message center.

When minor faults occur and the air suspension control module is able to level the vehicle to the 'current' ride height, the air suspension switch LED's will display the current ride height.

If the air suspension control module suffers a major failure and there is no air suspension control, all the control switch LED's will remain off.

If a fault occurs and the air suspension control module can determine the ride height and the vehicle is not above on-road mode height, the driver will be notified via a 'air suspension fault max speed 18.6 mph (30 km/h)' message in the message center.

If the control module cannot determine the height of the vehicle, or the vehicle is above on-road mode height, cannot be lowered and the vehicle speed is too high, an air suspension fault message is displayed.

If the vehicle is restricted to on-road mode height an air suspension fault normal height only message is displayed.

### AIR SUSPENSION SWITCH

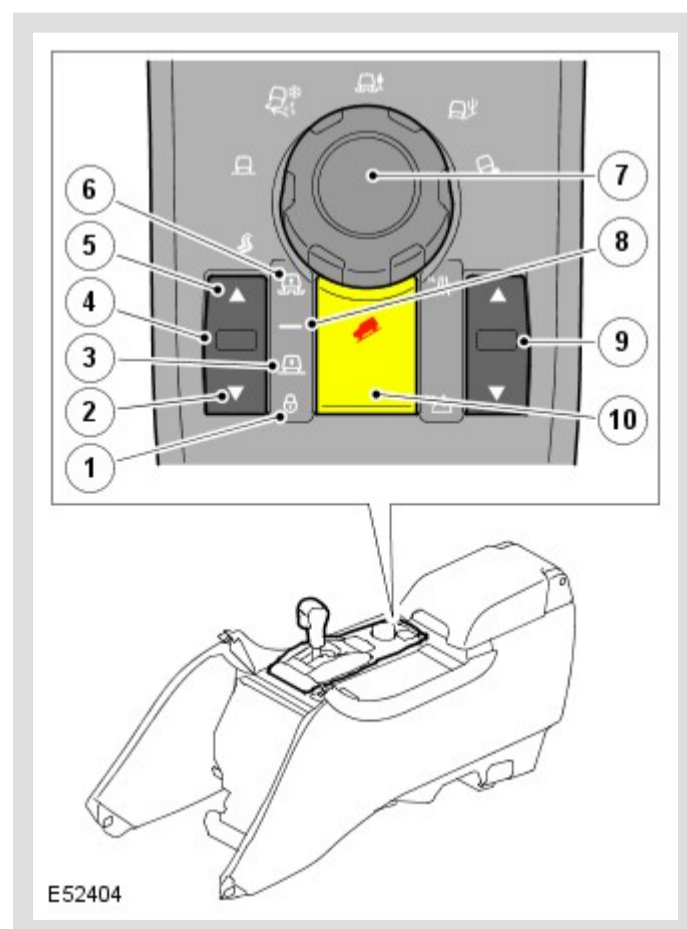

ITEM	DESCRIPTION
1	Crawl (locked at access) mode lamp
2	Lowering lamp
3	Access mode lamp
4	Air suspension switch
5	Raising lamp
6	Off-road mode lamp
7	Terrain Response™ rotary control
8	On-road (normal height) lamp
9	Transfer box range selection switch
10	Hill Descent Control (HDC) switch

The air suspension control switch is located in the center console, behind the automatic transmission selector lever. The switch is a three position, non-latching switch which allows selection of the following driver selectable modes:

- Off-road mode
- On-road mode
- Access mode
- Crawl (locked at access) mode.

The air suspension switch can be moved forwards or backwards from its central position. The switch is non-latching and returns to the central position when released. The switch completes a ground path to the air suspension control module when operated. This ground path is completed on separate wires for the raise and lower switch positions, allowing the control module to determine which selection the driver has made.

The switch has six symbols which illuminate to show the current selected height and the direction of movement. The raise and lower symbols will flash and a warning tone will be emitted from the instrument cluster sounder when a requested height change is not allowed, i.e. vehicle speed too fast.

A flashing symbol indicates that the air suspension system is in a waiting state or that the system will override the driver's selection because the speed threshold is too high.

The driver can also ignore the system's warning signals and allow the height to change automatically. For example, increasing the vehicle speed to more than 25 mph (40 km/h) will cause the control module to automatically change the ride height from off-road mode to on-road mode.

## FRONT AND REAR AXLE VALVE BLOCKS

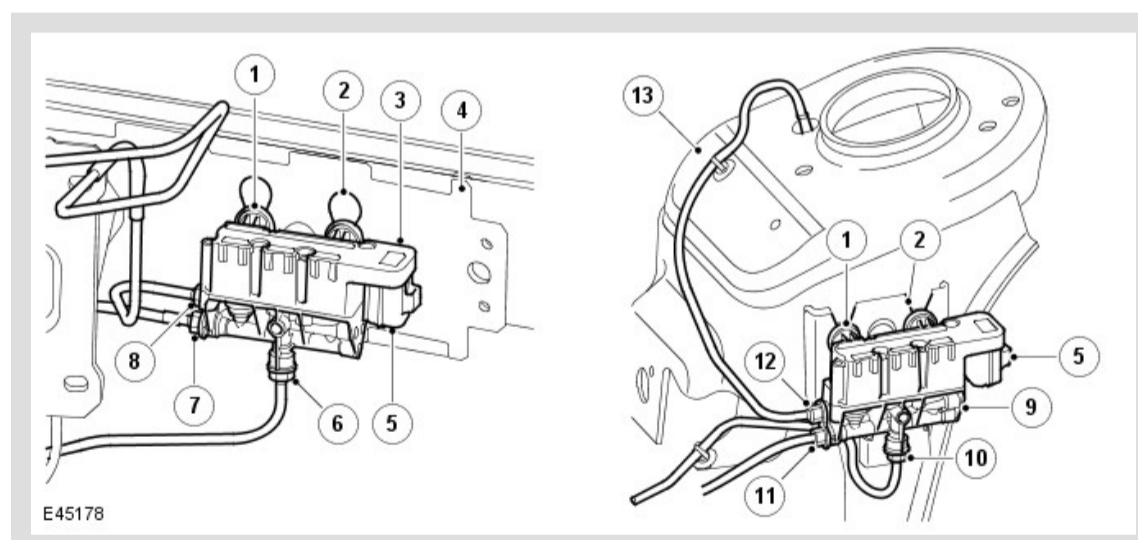

ITEM	DESCRIPTION
1	Isolation rubber mounts (3 off)
2	Location slots
3	Front valve block, valves and solenoid assembly
4	Front bumper armature
5	Electrical connector

6	LH air spring damper module air harness connection
7	Air inlet/outlet connection
8	RH air spring damper module air harness connection
9	Rear valve block, valves and solenoid assembly
10	RH air spring damper module air harness connection
11	Air inlet/outlet connection
12	LH air spring damper module air harness connection
13	Rear suspension turret

The front and rear axle valve blocks are similar in their design and construction and control the air supply and distribution to the front or rear pairs of air spring damper modules respectively. The difference between the two valves is the connections from the valve block to the left and right hand air spring damper modules and the valve size. It is important that the correct valve block is fitted to the correct axle. Fitting the incorrect valve block will not stop the air suspension system from functioning but will result in slow raise and lower times and uneven raising and lowering between the front and rear axles.

The front valve block is attached to the right hand end of the front bumper armature assembly. The valve block has three attachment lugs which are fitted with isolation rubber mounts. The rubber mounts locate in slots in the armature. The valve lugs locate in the holes above the slots and are pulled downwards into positive location in the slots.

The rear valve block is located on the forward face of the left hand rear suspension turret. The valve block has three attachment lugs which are fitted with isolation rubber mounts which locate in a bracket with three slotted holes. The bracket is attached to the left hand side of the chassis. The isolation rubber mounts locate in the 'V' shaped slots and are pulled downwards into positive location in the slots.

The front and rear valve blocks each have three air pipe connections which use 'Voss' type air fittings. One connection is an air pressure inlet/outlet from the reservoir valve block. The remaining two connections provide the pressure connections to the left and right hand air springs.

Each valve block contains three solenoid operated valves; two corner valves and one cross-link valve. Each of the valve solenoids is individually controlled by the air suspension control module. The solenoids have a resistance value of 2 Ohms at a temperature of 20°C (68°F).

#### CORNER VALVES

The corner valves control the flow of air into and out of the individual air springs. When the solenoid is de-energised, the corner valves are held in a closed position by internal springs. When the solenoid is energised, the valve armature moves and allows air to flow into or out of the air spring.

#### CROSS LINK VALVES

The cross-link valve provides a connection between the two air springs on the same axle. When de-energised, the cross-link valve prevents air passing from one air spring to another. When the solenoid is energised, the valve spool moves and allows air to pass from one air spring to the other. This increases wheel articulation and improves ride comfort at low vehicle speeds.

### RESERVOIR VALVE BLOCK

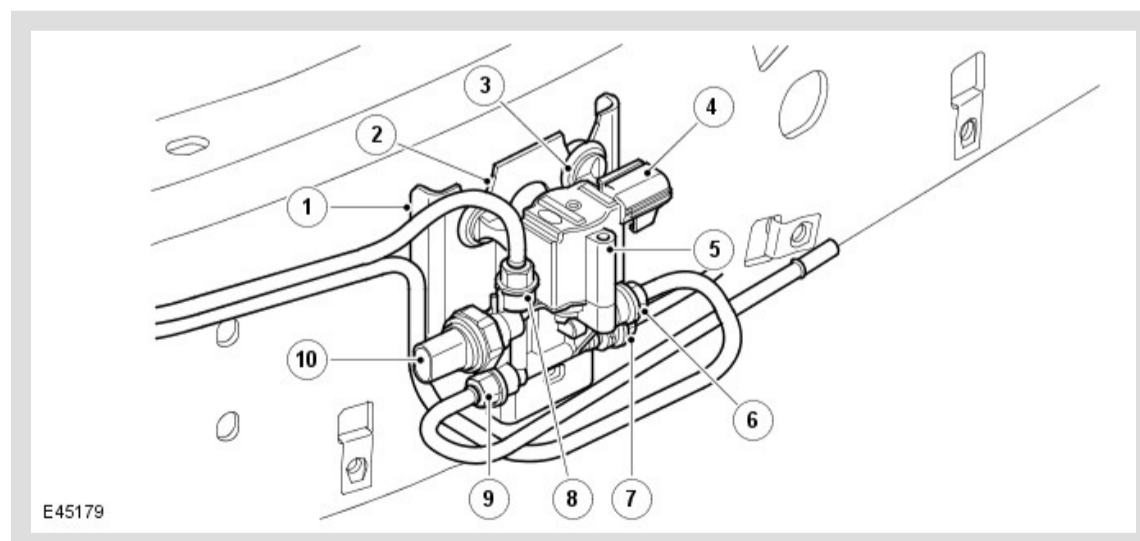

ITEM	DESCRIPTION
1	Chassis mounting bracket
2	Location slot
3	Isolation rubber mounts (3 off)

4	Electrical connector
5	Reservoir valve block, valves and solenoid assembly
6	Reservoir connection
7	Rear valve block connection
8	Front valve block connection
9	Air supply unit connection
10	Pressure sensor

The reservoir valve block controls the storage and distribution of air from the reservoir. The reservoir valve block also contains the system pressure sensor.

The reservoir valve block is attached to a bracket on the outside of the left hand chassis rail, between the reservoir and the air supply unit. The valve block is located within the air supply unit acoustic box to protect it from dirt ingress and damage from stones. The valve block has three attachment lugs which are fitted with isolation rubber mounts. The rubber mounts locate in the chassis bracket which has three corresponding 'V' shaped slots. the rubber mounts are pulled downwards into positive location in the slots.

The valve block has four air pipe connections which use 'Voss' type air fittings. The connections provide for air supply from the air supply unit, air supply to and from the reservoir and air supply to and from the front and rear valve blocks. The connections from the air supply unit and the front and rear control valves are all connected via a common gallery within the valve and therefore are all subject to the same air pressures.

The valve block contains a solenoid operated valve which is controlled by the air suspension control module. The solenoid valve controls the pressure supply to and from the reservoir. The solenoid has a resistance value of 2 Ohms at a temperature of 20°C (68°F). When energised, the valve spool moves allowing air to pass to or from the reservoir.

The valve block also contains a pressure sensor which can be used to measure the system air pressure in the air springs and the reservoir. The pressure sensor is connected via a harness connector to the air suspension control module. The control module provides a 5V reference voltage to the pressure sensor and monitors the return signal voltage from the sensor.

Using this sensor, the control module controls the air supply unit operation and therefore limits the nominal system operating pressure to 244 lbf/in<sup>2</sup> (16.8 bar gage).

---

## AIR SUPPLY UNIT

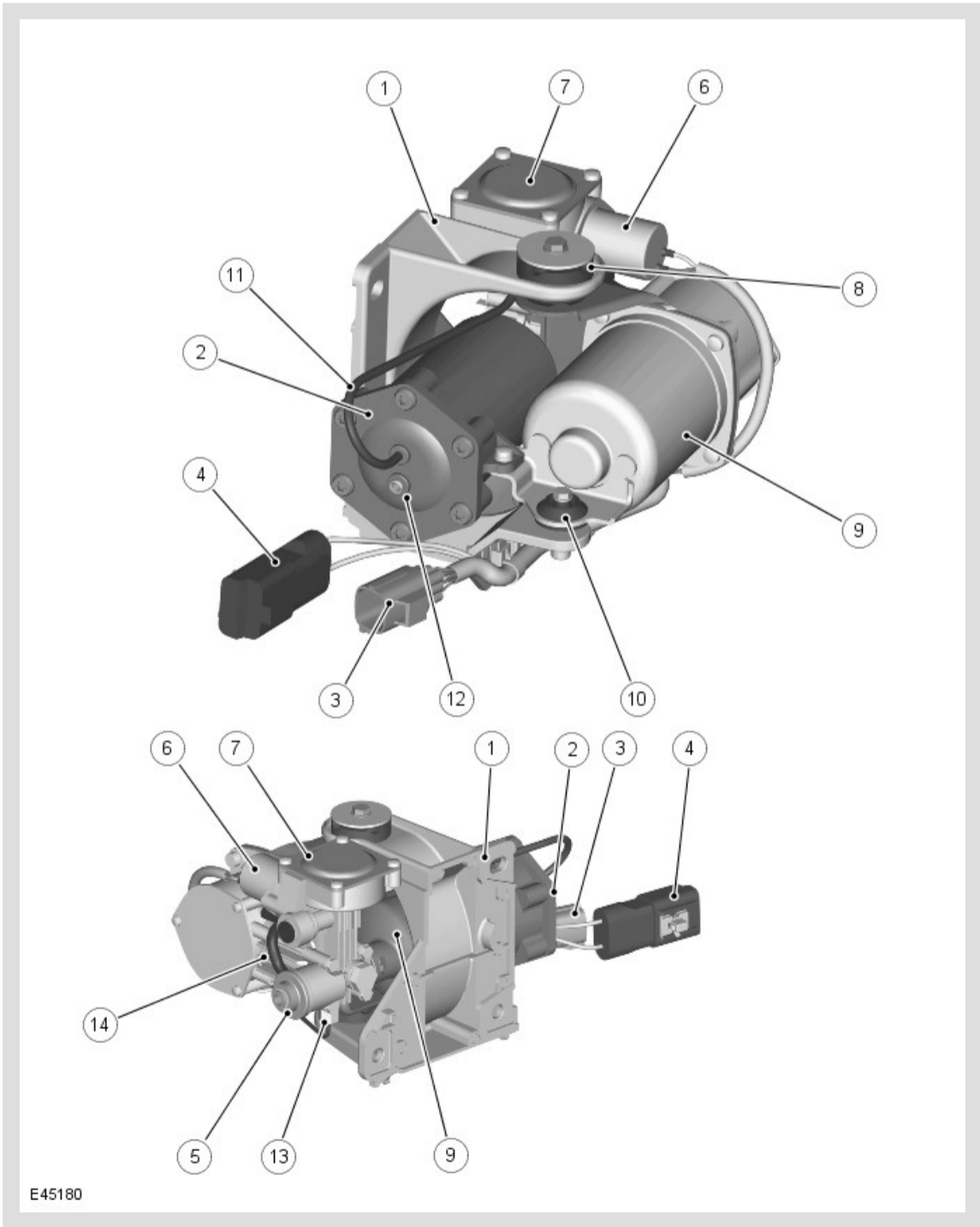

E45180

ITEM	DESCRIPTION
1	Mounting bracket

2	Air dryer
3	Pilot exhaust valve solenoid and temperature sensors harness connector
4	Motor harness connector
5	Intake port
6	Pilot exhaust valve
7	Exhaust valve
8	Isolation mounting rubber (2 off)
9	Electric motor
10	Isolation mounting rubber (1 off)
11	Pilot air pipe
12	Pressure outlet to pilot exhaust valve
13	Compressor cylinder head temperature sensor
14	Compressor

The air supply unit is located on the outside of the left hand chassis rail, forward of the upper control arm. The unit is attached to the chassis rail with three bolts and is protected by an acoustic box.

#### Acoustic Box

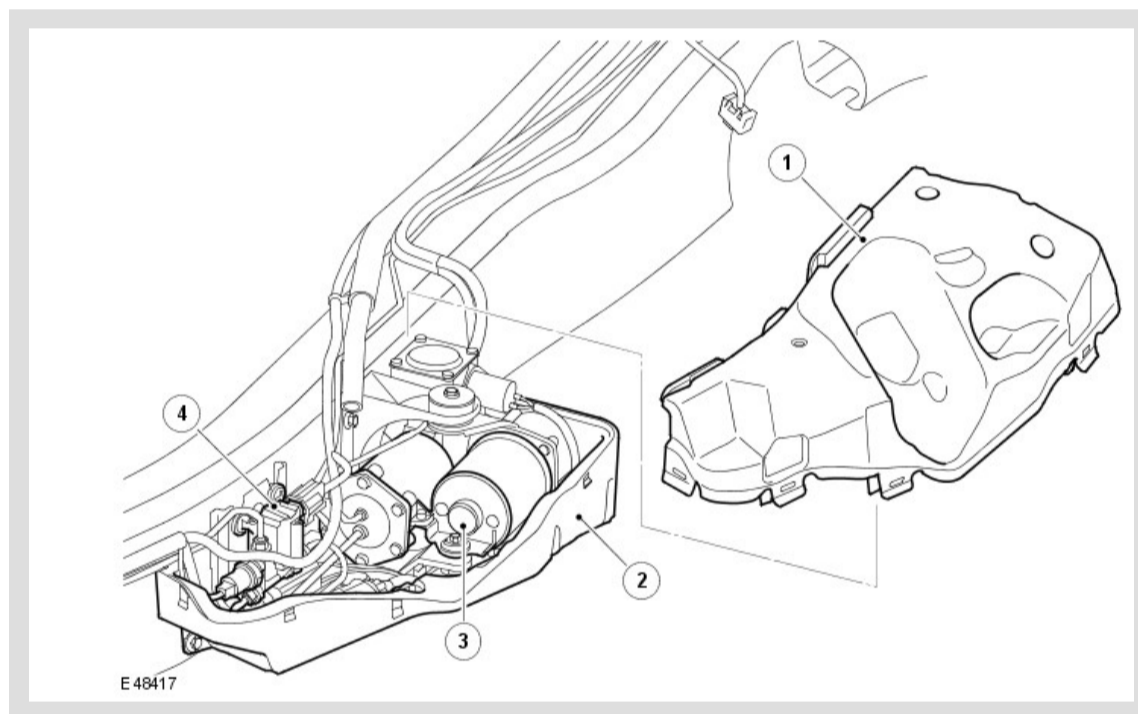

ITEM	DESCRIPTION
1	Upper cover
2	Lower cover
3	Air supply unit
4	Reservoir valve block

The acoustic box, which comprises of two parts; upper and lower, surrounds the air supply unit. The acoustic box is a plastic moulding which is lined with an insulating foam which controls the operating noise of the air supply unit. The reservoir valve block is also located in the acoustic box, forward of the air supply unit.

The air supply unit comprises the following major components:

- A piston compressor
- A 12V electric motor
- A solenoid operated pilot valve
- An exhaust valve
- An air dryer unit

The air supply unit can be serviced in the event of component failure, but is limited to the following components; air dryer, pilot exhaust pipe and the rubber mounts.



The air supply unit is attached to a bracket which is bolted to the chassis. The unit is mounted to the bracket with flexible isolation mounting rubbers which assist with preventing operating noise being transmitted to the chassis.

Removal of the air supply unit does not require the whole air suspension system to be depressurised. The front and rear valve blocks and the reservoir valve block are normally closed when de-energised, preventing air pressure in the air springs and the reservoir escaping when the unit is disconnected.

There are a number of conditions that will inhibit operation of the air supply unit. It is vitally important that these system inhibits are not confused with a system malfunction. A full list of air supply unit inhibits are given in the air suspension control module section in this chapter.

Air Supply Unit - Sectional View

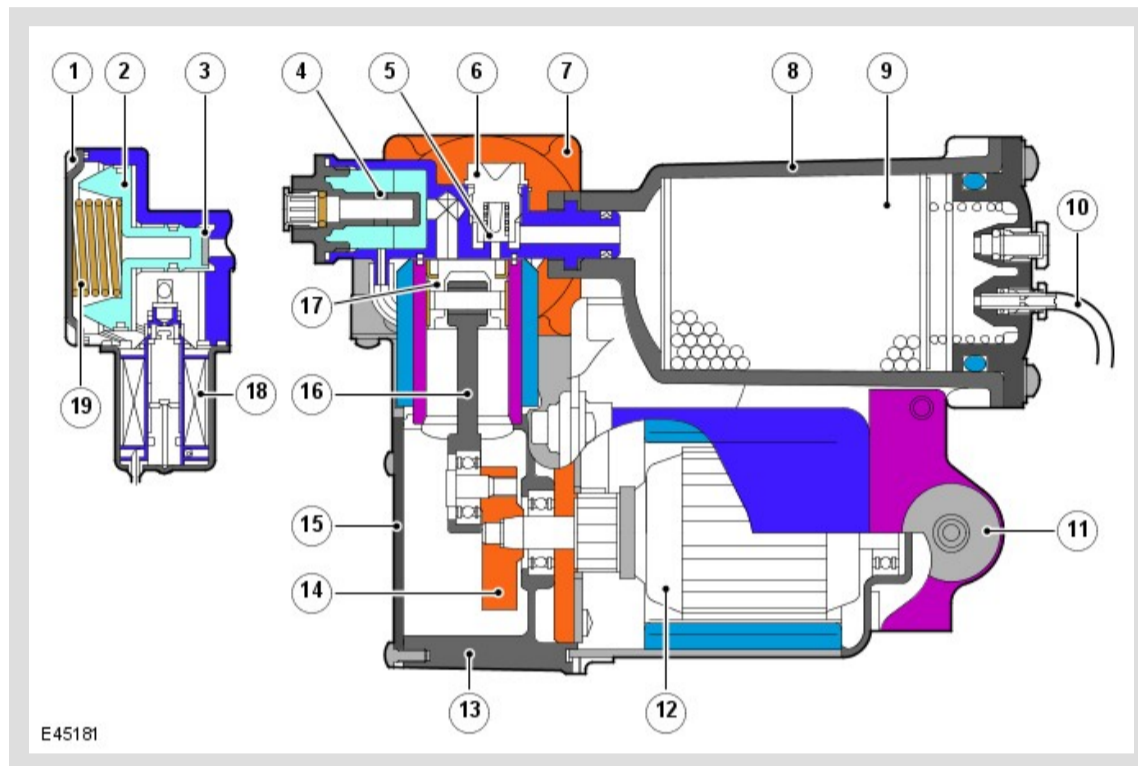

ITEM	DESCRIPTION
1	Exhaust valve cap
2	Plunger
3	Valve seat
4	Intake silencer port
5	Delivery valve
6	Valve guide
7	Cylinder head
8	Dryer case
9	Desiccant
10	Pilot exhaust line
11	Isolation rubber mount
12	Motor assembly
13	Crankcase
14	Crank
15	Crankcase cover
16	Connecting rod
17	Piston
18	Pilot exhaust valve
19	Spring - pressure relief

#### PILOT EXHAUST VALVE

A solenoid operated pilot exhaust valve is connected to the air delivery gallery, downstream of the air dryer. The pilot valve, when opened, operates the main compressor exhaust valve. This allows the air springs to be deflated when required.

When the solenoid is energised, pilot air moves the exhaust valve plunger, allowing pressurised air from the air springs and/or reservoir to pass via the reservoir control valve to the air supply unit.

The solenoid has a resistance value of 4 Ohms at a temperature of 20°C (68°F).

### EXHAUST VALVE

The exhaust valve has three functions. It operates in conjunction with the pilot exhaust valve to allow air to be exhausted from the air springs and/or the reservoir as described previously.

The valve also protects the system from over-pressure. The valve is connected into the main pressure gallery which is always subject to the system pressure available in either the air springs or the reservoir. The valve is controlled by a spring which restricts the maximum operating pressure to between 319 to 391 lbf/in<sup>2</sup> (22.0 to 27 bar gage).

The minimum pressure in the system is also controlled by the exhaust valve to ensure that, even when deflated, the air springs contain a positive pressure of approximately 14.5 lbf/in<sup>2</sup> (1 bar gage) with respect to atmosphere. This protects the air spring by ensuring it can still 'roll' over the piston without creasing.

### ELECTRIC MOTOR

The electric motor is a 12V dc motor with a nominal operating voltage of 13.5V. The motor drives a crank which has an eccentric pin to which the compressor connecting rod is attached.

The motor is fitted with a temperature sensor on the brush PCB assembly. The sensor is connected to the air suspension control module which monitors the temperature and can suspend motor operation if an overheat condition occurs.

### COMPRESSOR

The compressor comprises a motor driven connecting rod and piston which operate in a cylinder with a cylinder head. The motor rotates the crank moving the piston up and down in the cylinder bore. The air in the cylinder is compressed with the up stroke and is passed via a delivery valve, through the air dryer into the system.

### AIR DRYER

The air dryer is an integral part of the air supply unit. The air dryer contains a desiccant which absorbs moisture. Pressurised air is passed through the air dryer which removes any moisture in the compressed air before it is passed to the reservoir and/or the system

When the air is exhausted from the system, the returning air is passed through the air dryer, regenerating the air dryer by removing moisture from the desiccant and expelling it to atmosphere via the exhaust.

The air dryer is an essential component in the system ensuring that only dry air is present in the system. If moist air is present in the system, freezing can occur, resulting in poor system operation or component malfunction/failure.

## AIR RESERVOIR

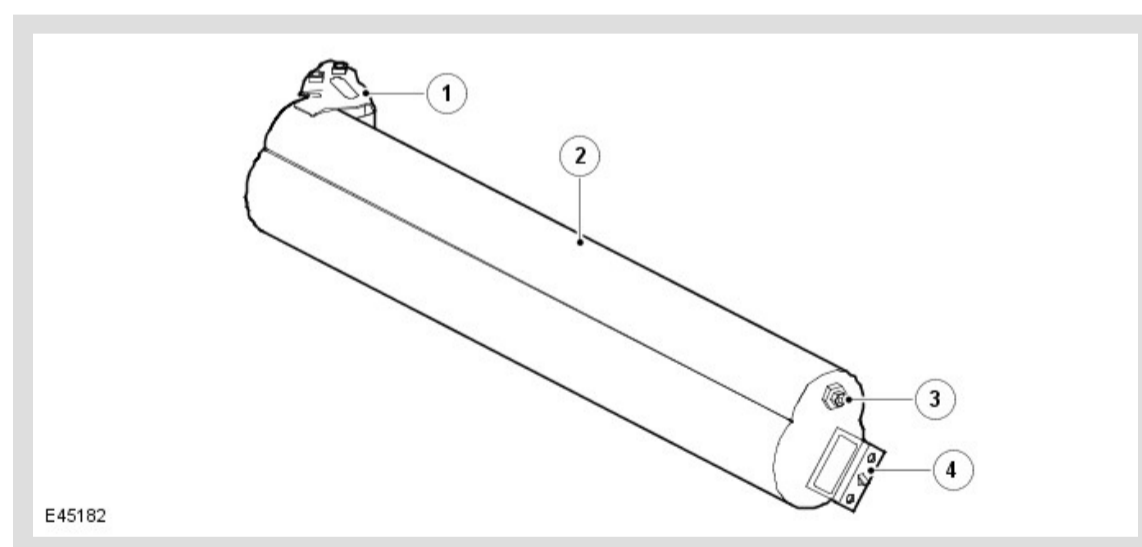

ITEM	DESCRIPTION
1	Front bracket
2	Reservoir
3	Air hose connection to reservoir valve block
4	Rear bracket

The reservoir is an air storage vessel which provides fast air suspension lift times by the immediate availability of pressurised air into the system.

The reservoir is a steel fabrication and is located on the outside of the left hand chassis rail, in front of the air supply unit. The reservoir has a bracket at each end which attach to the body mounting brackets on the chassis.

The rearward end of the reservoir has a 'Voss' air fitting which provides for the connection of the air hose between the reservoir and the reservoir valve block.

The reservoir has a capacity of 550 in<sup>3</sup> (9 liters). The nominal working pressure of the reservoir is 243.6 lbf/in<sup>2</sup> (16.8 bar gage), with a maximum pressure of 507 lbf/in<sup>2</sup> (35 bar gage).

## HEIGHT SENSORS

### Front Height Sensor

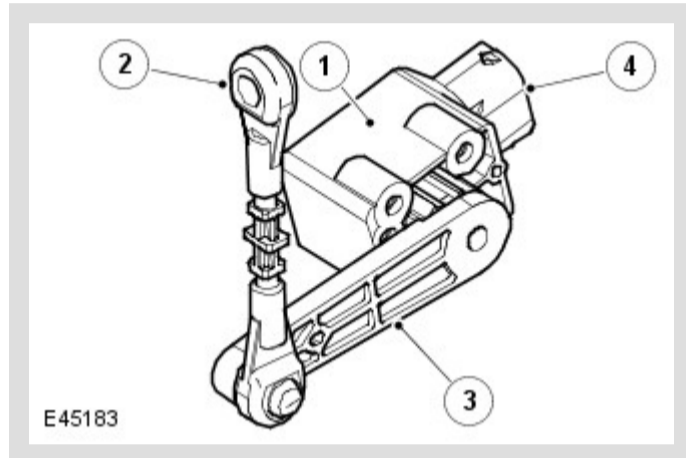

ITEM	DESCRIPTION
1	Sensor body
2	Drop link
3	Lever arm
4	Electrical connector

### Rear Height Sensor

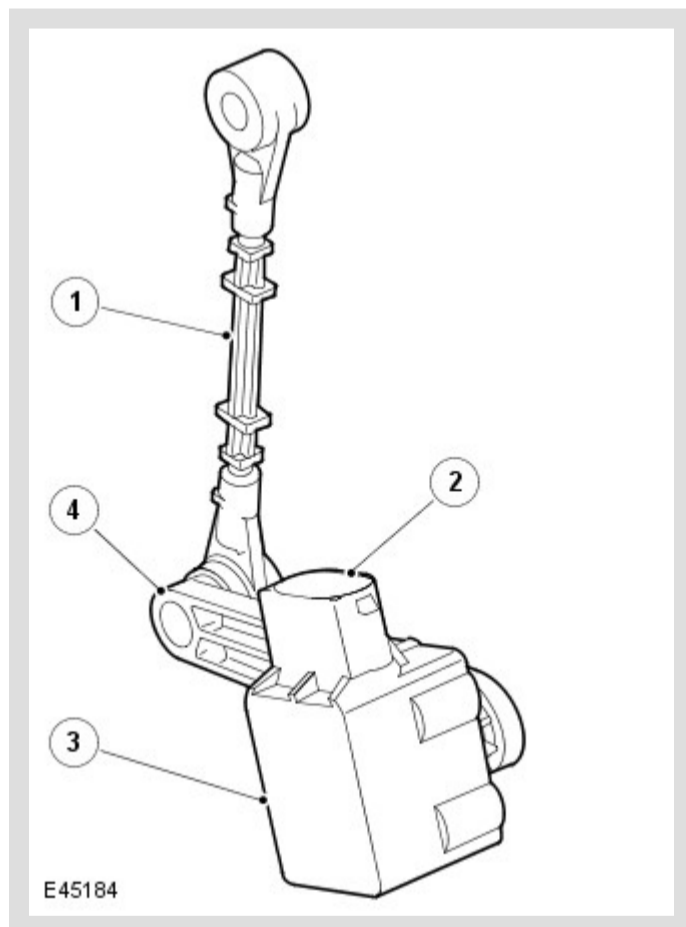

ITEM	DESCRIPTION
1	Drop link
2	Electrical connector
3	Sensor body
4	Lever arm

A height sensor is fitted in each corner of the vehicle to monitor the ride height of the vehicle. The sensor bodies are attached with screws to brackets on the chassis rails.

Each sensor comprises a sensor body which contains a single track rotary potentiometer, a lever arm and a drop link.

The sensor lever arm has a drop link which provides the connection between the sensor and the suspension control arm. The drop link is a serviceable component and is a push fit to the lever arm and the suspension control arm.

The sensors are connected via their harness connector to the air suspension control module which receives the signal output from each sensor and, using preprogrammed information, converts the signal to a height for each sensor position.

The front left and right hand sensors are common parts. The left and right hand rear sensors are handed. All are color coded for identification as follows:

- Left and right hand front - gray lever arm, white plastic drop link
- Left hand rear - white colored lever arm, black plastic drop link
- Right hand rear - black colored lever arm, black plastic drop link.

#### CALIBRATION

A calibration routine is performed using T4 to read the position of each corner of the vehicle and record the settings in the control module memory. Once set, the calibration is not required to be performed unless the air suspension control module is removed or replaced, a height sensor is removed or replaced or a suspension arm to which the sensor is connected is removed or replaced. If the removed height sensor is subsequently refitted, the calibration procedure will have to be performed to ensure the integrity of the system.

If a replacement drop link is fitted, recalibration is not required providing the sensor body is not removed from its mounting bracket.

#### AIR SILENCER AND INLET AIR FILTER

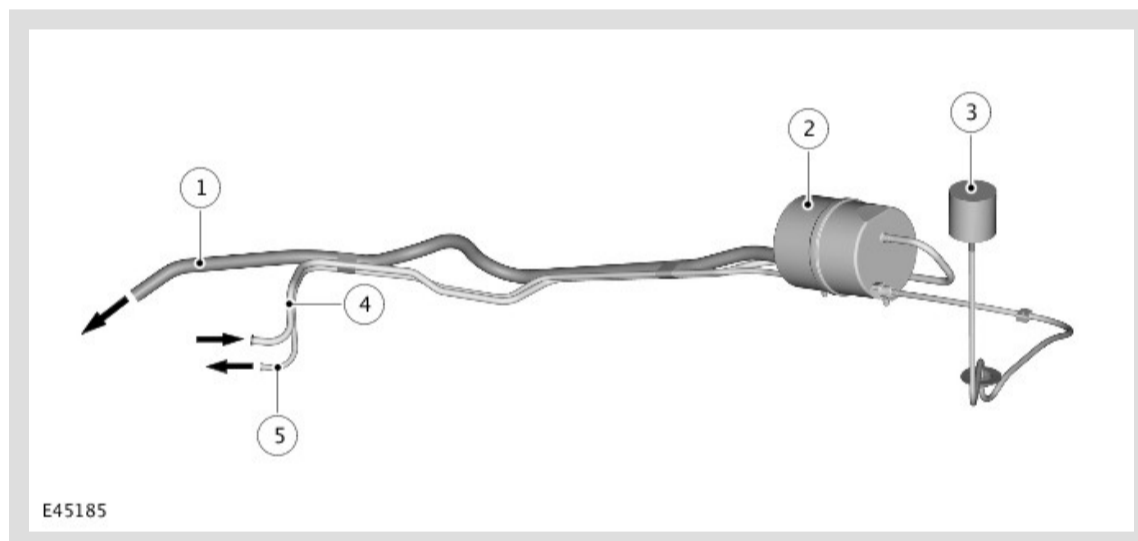

ITEM	DESCRIPTION
1	Exhaust (to atmosphere)
2	Inlet and exhaust silencer
3	Air inlet filter
4	Exhaust air from air supply unit
5	Air inlet supply to air supply unit

The air silencer is required to limit any noise produced from the air supply unit during inflation or deflation of the air springs.

The silencer comprises two plastic moulded cans, which are bonded together with a silencing foam filling the large internal chamber which forms the exhaust silencer. A pipe connection is moulded onto each end of the silencer and provides for the attachment of the exhaust air to atmosphere pipe and the exhaust air pipe from the air supply unit.

A secondary chamber, located around the outside of the exhaust chamber forms the silencer for the inlet air. Pipe connections are moulded onto each end of the intake silencer and provide for the attachment of the air inlet pipe from the inlet air filter and the air inlet pipe to the air supply unit. The intake air silencer is a hollow chamber with no noise reduction foam filling.

The air intake filter is connected via a pipe to the intake silencer chamber of the air silencer unit. The filter is located in the rear left hand corner of the body, away from possible sources of dirt and moisture.

The filter contains a foam element which removes particulate matter from the inlet air before it reaches the silencer or the air supply unit.

## AIR HARNESS

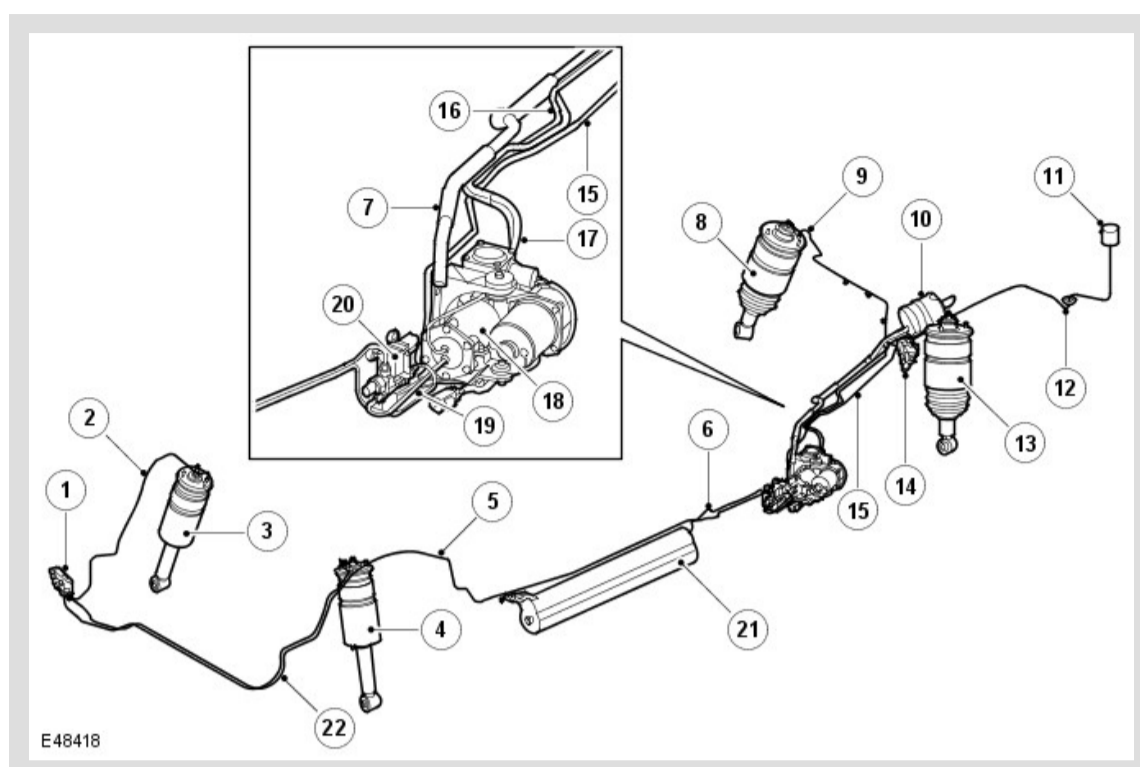

ITEM	DESCRIPTION
1	Front axle valve block
2	Pipe - Front axle valve block to front RH air spring damper module
3	Front RH air spring damper module
4	Front LH air spring damper module
5	Pipe - Reservoir valve block to front axle valve block
6	Pipe - Reservoir valve block to reservoir
7	Pipe - Exhaust
8	Rear RH air spring damper module
9	Pipe - Rear axle valve block to rear RH air spring damper module
10	Air silencer assembly
11	Air inlet filter
12	Pipe - Main inlet
13	Rear LH air spring damper module
14	Rear axle valve block
15	Pipe - Reservoir valve block to rear axle valve block
16	Pipe - Compressor inlet
17	Pipe - Compressor exhaust
18	Air supply unit
19	Pipe - Air supply unit to reservoir valve block
20	Reservoir valve block
21	Reservoir
22	Pipe - Front axle valve block to front LH air spring damper module

The air harness comprises ten separate nylon pipes which are connected between the system components with Voss connectors. The pipes have the following diameters:

PIPE	DIAMETER
High pressure pipes	6 mm
Compressor inlet pipe	8 mm
Inlet filter to silencer	8 mm
Compressor exhaust pipe	10 mm

If a pipe becomes damaged, an in-line connector is available for repair purposes. The pipes are secured to the body and the chassis with a number of plastic clips.

**CONTROL DIAGRAM**

**NOTE:**

A = Hardwired

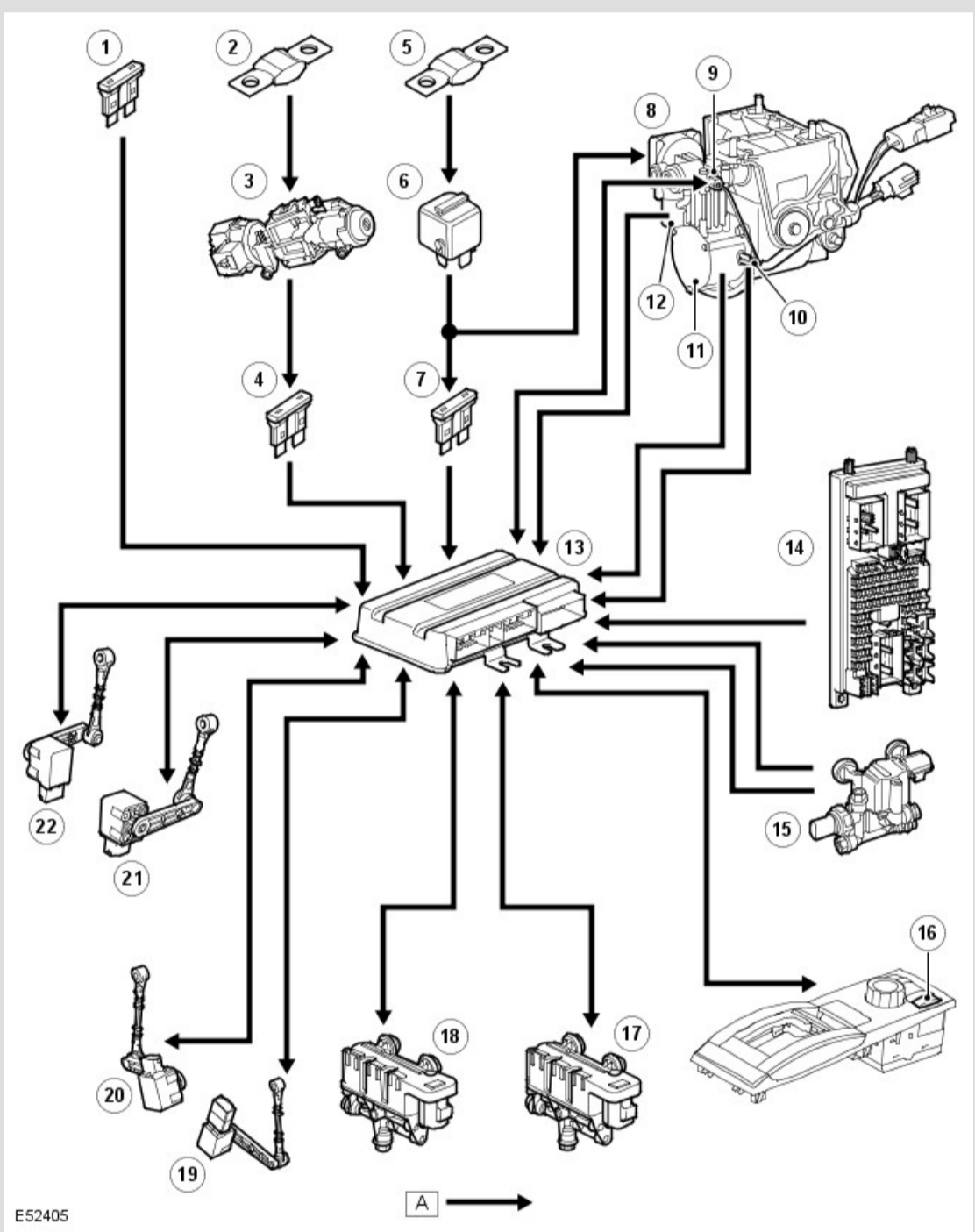

ITEM	DESCRIPTION
1	Fuse 26E (20A)
2	Fusible link 11E (30A)
3	Ignition switch
4	Fuse 35P (5A)
5	Fusible link 10E (60A)
6	Air supply unit relay
7	Fuse 3E (5A)
8	Air supply unit
9	Compressor temperature sensor
10	Motor temperature sensor
11	Motor
12	Exhaust valve solenoid

13	Air suspension control module
14	CJB
15	Reservoir control valve
16	Air suspension switch
17	Front control valve
18	Rear control valve
19	RH rear height sensor
20	LH rear height sensor
21	RH front height sensor
22	LH front height sensor