

Network Devices

Hub

- An OSI layer 1 device
- Multi-port repeater
- Everything is half-duplex
- Becomes less efficient as speeds increase

Switch

- An OSI layer 2 device
- Hardware bridging ASICs (very fast!)
- Forwards traffic based on MAC address
- The core of an enterprise network
- High bandwidth - Many simultaneous packets

Router

- An OSI layer 3 device
- Routes traffic between IP subnets
- Routers inside of switches are sometimes called "layer 3 switches"
- Layer 2 = Switch, Layer 3 = Router
- Often connects diverse network types - LAN, WAN, copper, fiber

Firewall

- OSI layer 4 (TCP/UDP), some firewalls filter through OSI layer 7
- Filters traffic by port number
- Can encrypt traffic into/out of the network and between sites
- Can proxy traffic - A common security technique
- Most firewalls can be layer 3 devices (routers)

Wireless Access Point

- OSI layer 2 device
- Not a wireless router
- A WAP is a bridge - makes forwarding decisions based on MAC address

Modem

- Modulator / Demodulator
- Uses standard phone lines
- POTS modems now used for backup and utility functions

Intrusion detection/prevention system

- Protects against OS and application exploits
- Detection - alerts but does not stop the attack
- Prevention - blocks the attack
- Network-based - high-speed appliances
- Host-based - runs on your operating system

Content Filters

- Control traffic based on network data
- Filter email - avoid malicious software, phishing, and viruses
- Filter URLs - filter by web site category

Load balancer

- Distributes the load over many physical servers
- Adds fault-tolerance
- Can cache and prioritize traffic
- Very common in large environments

Packet shaper, traffic shaper

- Control by bandwidth usage or data rates
- Set important applications to have higher priorities than other apps
- Manage the Quality of Service (QoS)

VPN concentrator

- The connection point for remote users
- Traffic is encrypted across the Internet and decrypted on the internal private network

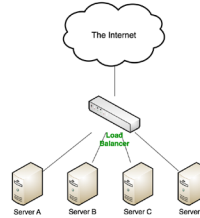

Application	Priority	Description
HTTP	High	Web Applications
SMTP	High	Exchange Mail Applications
POP3	High	Outgoing Mail Applications
IMAP	High	Outgoing Mail Applications
FTP	High	File Applications
SSH	High	Secure Shell Applications
VPN	High	VPN Applications
SQL	High	SQL Applications
LDAP	High	LDAP Applications
SMTP	Normal	SMTP Applications
IMAP	Normal	IMAP Applications
POP3	Normal	POP3 Applications
HTTP	Normal	HTTP Applications

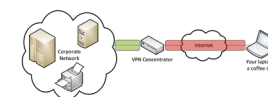

VPN Protocols

PPP (Point-to-Point Protocol)

- Authentication, compression, error detection, multilink
- Used in many physical networking environments
- Layer 2 protocol

PPTP (Point to Point Tunneling Protocol)

- PPTP protocol controls the tunnel
- GRE (Generic Routing Encapsulation) is the tunnel
- Authentication - MS-CHAPv2 (Microsoft Challenge-Handshake Authentication Protocol)
- Encryption - EAP-TLS (Extensible Authentication Protocol – Transport Layer Security)

SSL VPN (Secure Sockets Layer VPN)

- Uses common SSL protocol (tcp/443)
- No big VPN clients

IPSec (Internet Protocol Security)

- Security for OSI layer 3
- Confidentiality and integrity/anti-replay
- Two core IPSec protocols - Authentication Header (AH) and Encapsulation Security Payload (ESP)

Virtual Private Networking (VPN)

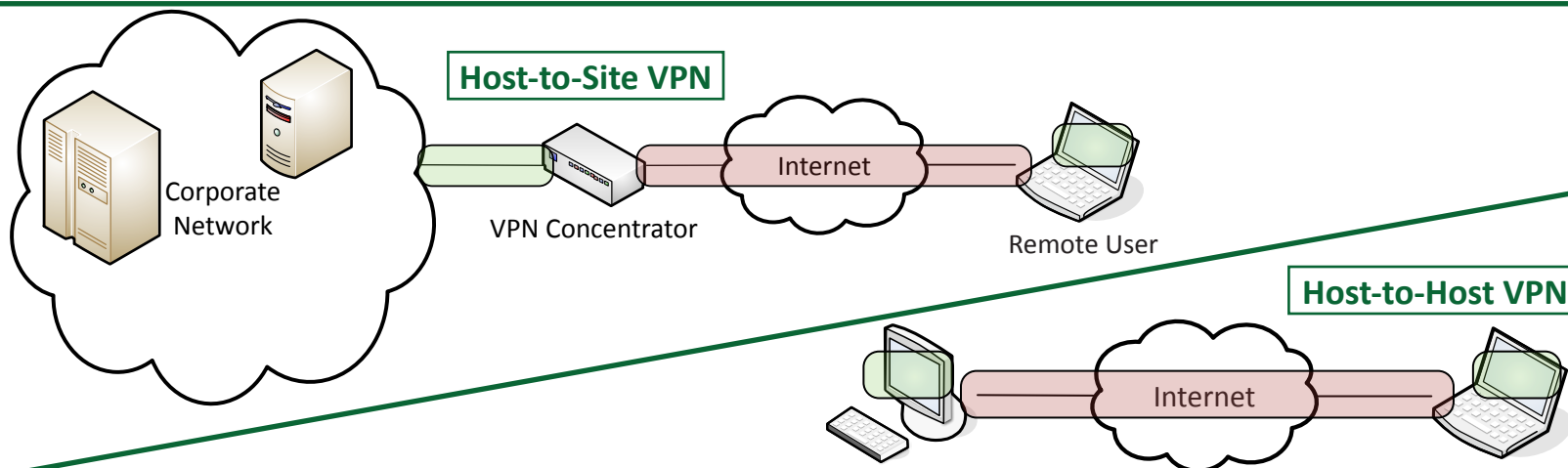
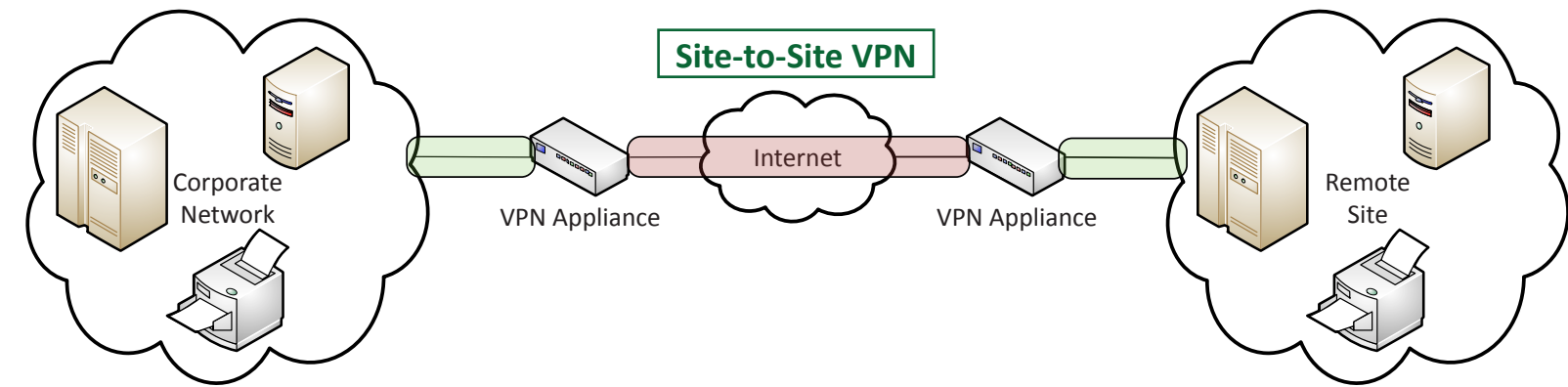

DHCP Lease Renewal

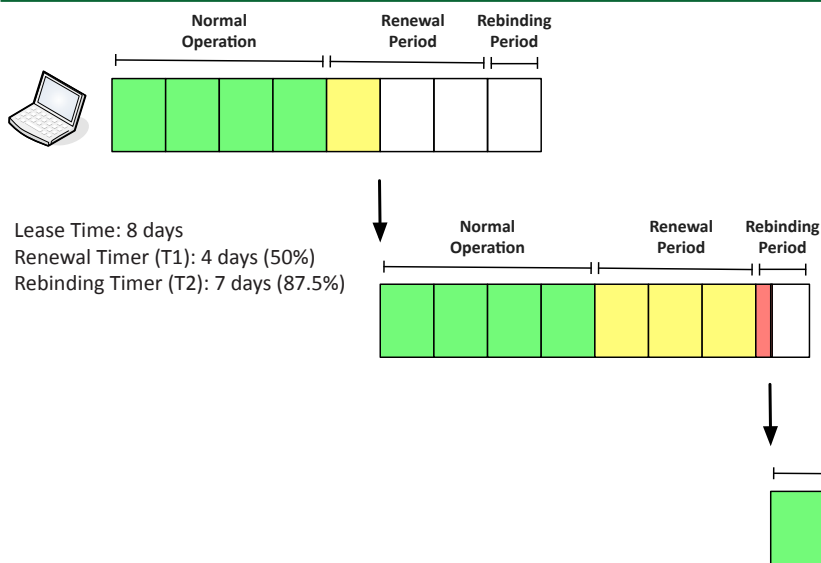

The DHCP Process

- Step 1: DHCPDISCOVER - Client to DHCP Server
 - Find all of the available DHCP Servers
- Step 2: DHCPOFFER - DHCP Server to client
 - Send some IP address options to the client
- Step 3: DHCPREQUEST - Client to DHCP Server
 - Client chooses an offer and makes a formal request
- Step 4: DHCPACK - DHCP Server to client
 - DHCP server sends an acknowledgement to the client

DNS Resolution Process

- 1 - Request sent to local name server
- 2 - Name server queries root server
- 3 - Root response sent to local name server
- 4 - Name server queries .com name server
- 5 - .com Response sent to local name server
- 6 - Name server queries specific domain server
- 7 - Domain server responds to name server
- 8 - Name server provides result to local device
- 9 - Answer is cached locally

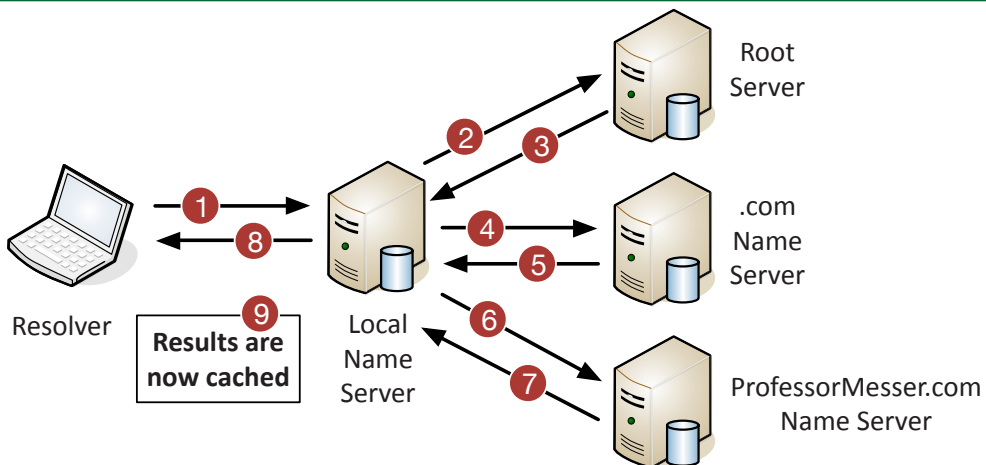

DNS Records

- A and AAAA - Address
- CNAME - Canonical name
- MX - Mail exchanger
- NS - Name server
- PTR - Pointer

Proxy Servers

- 1 - Client makes the request to the proxy
- 2 - The proxy performs the actual request
- 3 - The proxy provides results back to the client

Proxies can provide access control, caching, URL filtering, content scanning, etc.

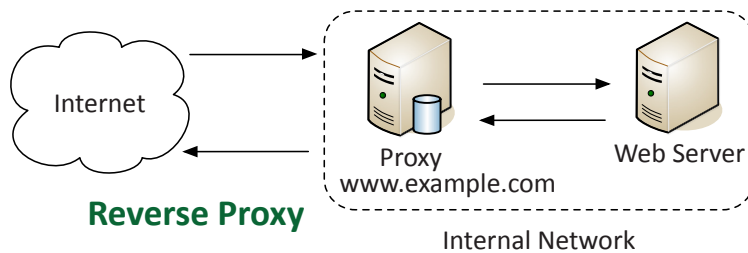
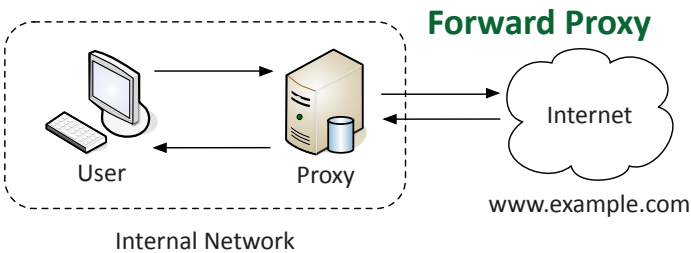
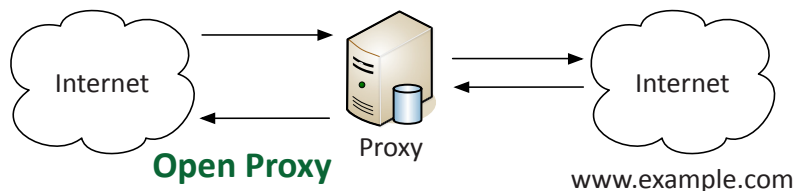

PAT (Port Address Translation / Source NAT)

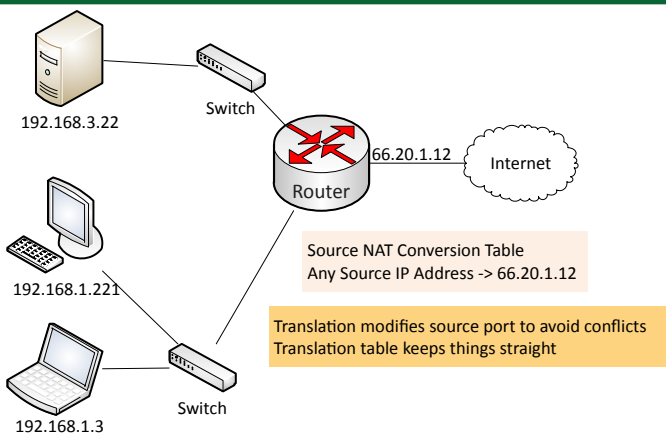

Static NAT / Destination NAT

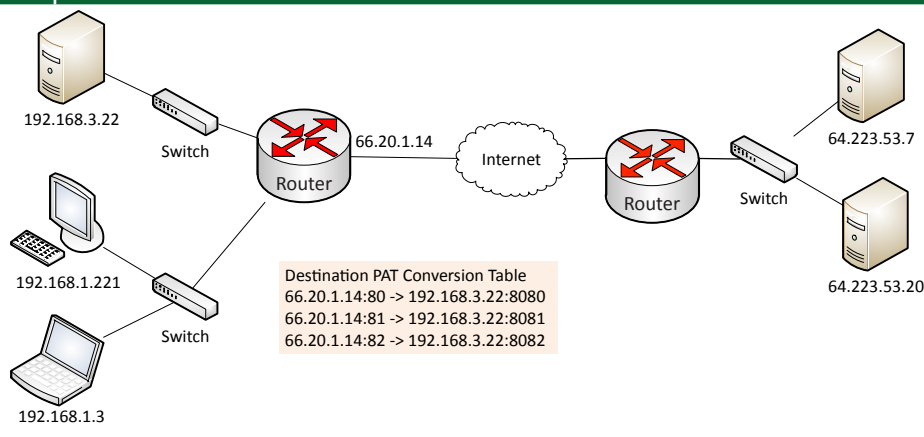

WAN Technologies

SONET	SDH	Bandwidth
STS-1 / OC-1	STM-0	51.84 Mbps
STS-3 / OC-3	STM-1	155.52 Mbps
STS-12 / OC-12	STM-4	622.08 Mbps
STS-48/OC-48	STM-16	2.488 Gbps
STS-96 / OC-96	STM-32	4.876 Gbps
STS-192 / OC-192	STM-64	9.953 Gbps
STS-768 / OC-768	STM-256	39.813 Gbps

Frame Relay

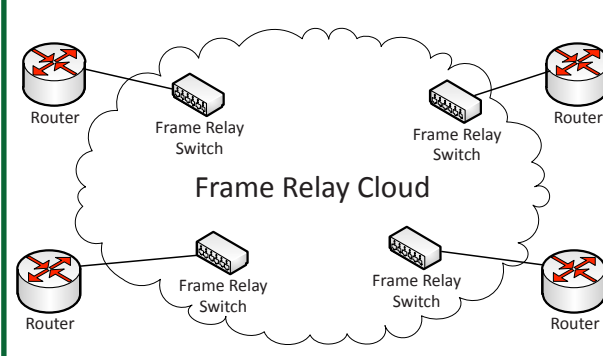

Cellular networks

- Land is separated into "cells"
- 2G networking (GSM, CDMA)

LTE (Long Term Evolution)

- Based on GSM/EDGE
- 300 Mbit/s down, 75 Mbit/s up

HSPA+ (Evolved High Speed Packet Access)

- Based on CDMA
- 84 Mbit/s down, 22 Mbit/s up

WiMAX

- Worldwide Interoperability for Microwave Access
- Fixed WiMax (IEEE 802.16)
 - 37 Mbit/s down, 17 Mbit/s up

Mobile WiMAX (IEEE802.16e-2005)

- 1 Gbit/s for fixed stations
- 100 Mbit/s for mobile stations

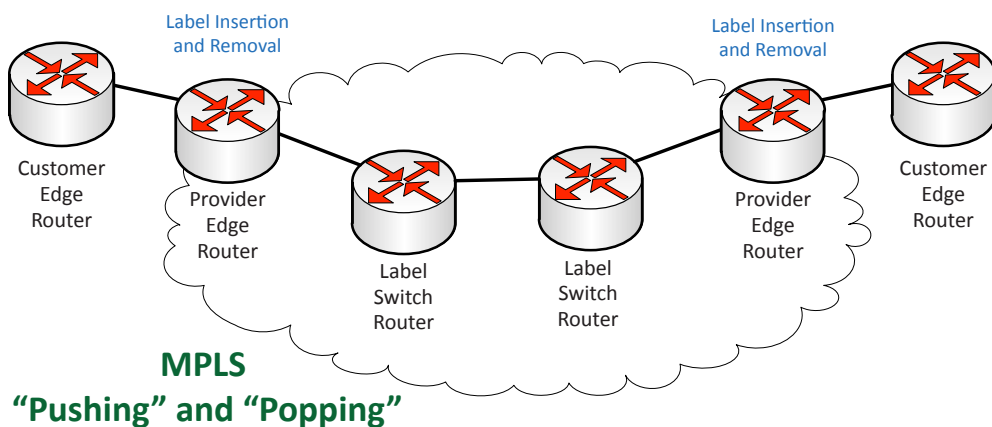



Satellite Networking

- 15 Mbit/s down, 2 Mbit/s up
- High latency (250 ms up, 250 ms down)
- High frequencies (line of sight, rain fade)

ISDN (Integrated Services Digital Network)

- BRI - Basic Rate Interface (2B+D)
 - Two 64 kbit/s bearer (B) channels
 - One 16 kbit/s signaling (D) channel
- PRI - Primary Rate Interface (23B+D)
 - T1 – 23B + D
 - E1 – 30B + D + alarm channel

DSL (Digital Subscriber Line)

- ADSL (Asymmetric DSL)
 - 24 Mbit/s down, 3.5 Mbit/s up
- SDSL (Symmetric DSL)
 - Never standardized
- VDSL (Very high bitrate DSL)
 - 4 Mbit/s through 100 Mbit/s

PPPoE

- Encapsulate point-to-point protocol over Ethernet
- Common on DSL networks
- Many similarities to dial-up networking

Cable modem

- DOCSIS (Data Over Cable Service Interface Specification)
- 4 Mbit/s through 100 Mbit/s

Dial-up

- Legacy systems
- 56 kbit/s, compression up to 320 kbit/s



Network	Channels	Line Rate
T1	24 at 64 kbit/s	1.544 Mbit/s
E1	32 at 64 kbit/s	2.048 Mbit/s
T3	28 T1 circuits 672 T1 channels	44.736 Mbit/s
E3	16 E1 circuits 512 E1 channels	33.368 Mbit/s

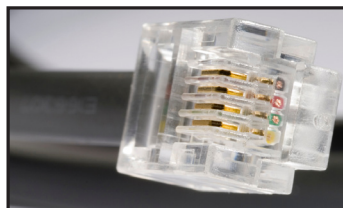

RJ-11 Cable

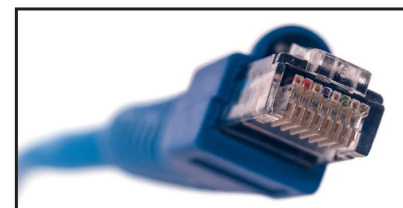

RJ-45 Cable



DB-25

DB-9



RJ-45 Coupler

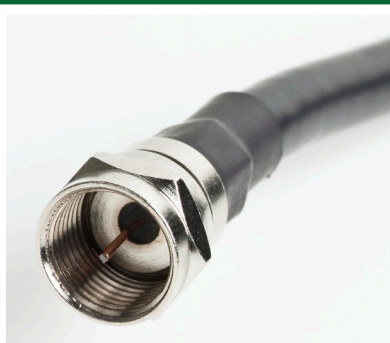

RG-6 Cable



BNC Cable



BNC Coupler

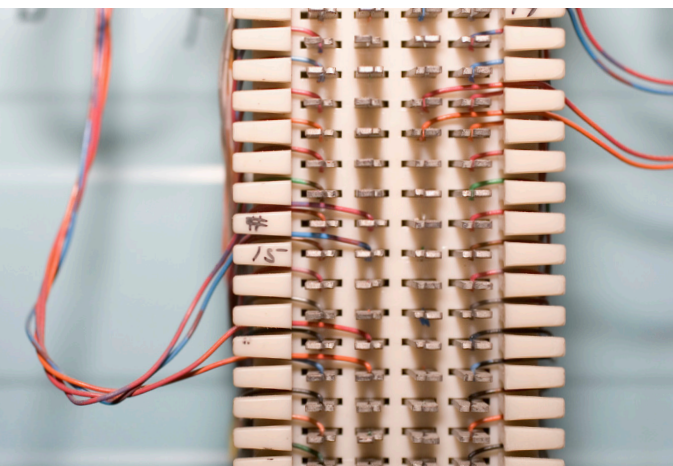

66 block

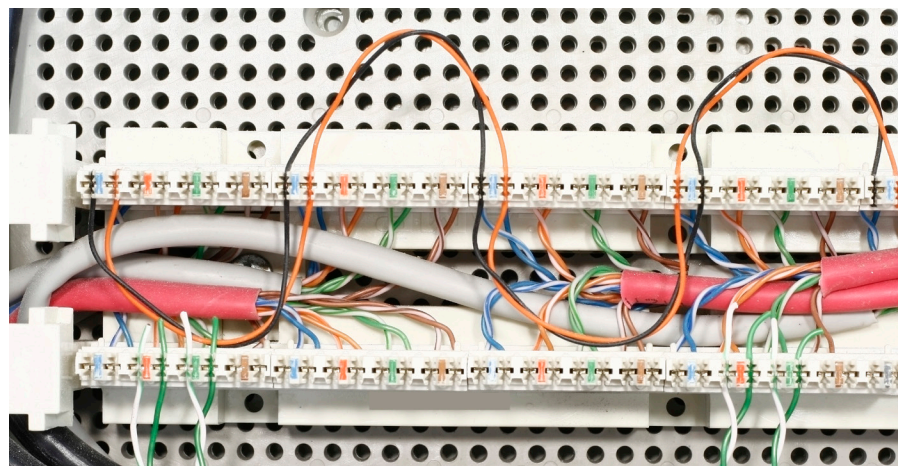

110 block

Copper Cabling

Twisted Pair Cabling

- STP (Shielded Twisted Pair)
- UTP (Unshielded Twisted Pair)
- Plenum-rated cable
 - Fire-resistant cable jacket

Coaxial Cabling

- RG-59 - Short-distance video
- RG-6 - Television, digital cable Internet

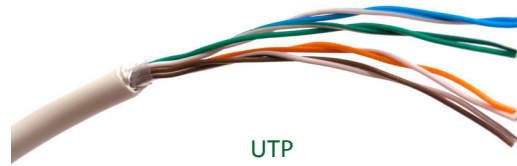

UTP
Unshielded Twisted Pair

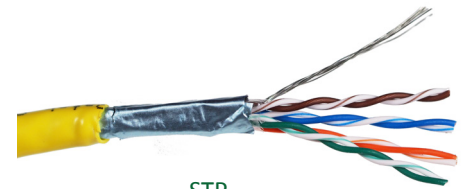

STP
Shielded Twisted Pair

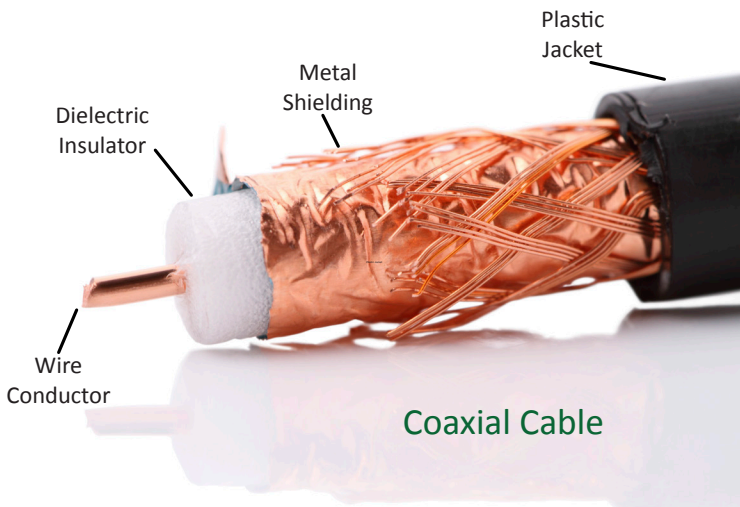

Coaxial Cable

Cable Category	Ethernet Standard	Maximum Distance
Category 3	10BASE-T	100 meters
Category 5	100BASE-TX, 1000BASE-T	100 meters
Category 5e (enhanced)	100BASE-TX, 1000BASE-T	100 meters
Category 6	10GBASE-T	37 to 55 meters
Category 6A (augmented)	10GBASE-T	100 meters

EIA/TIA-568 Standard Pin Assignments

TIA/EIA 568A



1 2 3 4 5 6 7 8



TIA/EIA 568B



TIA/EIA 568B Straight Through Cable



1000BASE-T Straight-through

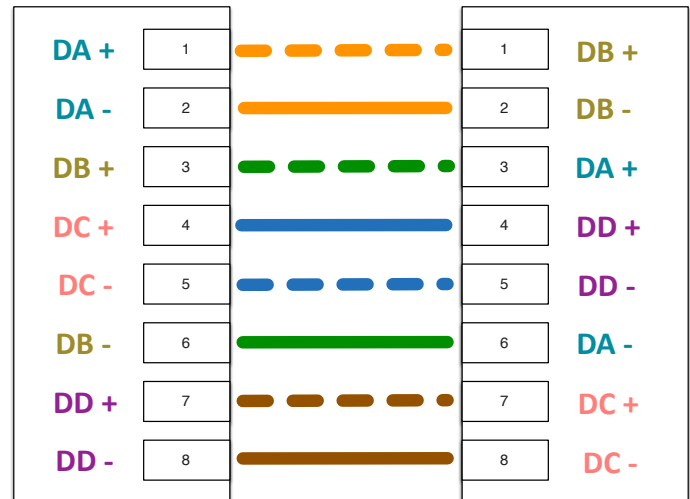

Media Dependent Interface (MDI)
Network Interface Card

Media Dependent Interface Crossover (MDI-X)
Network Switch

Copper Cabling

1000BASE-T Crossover

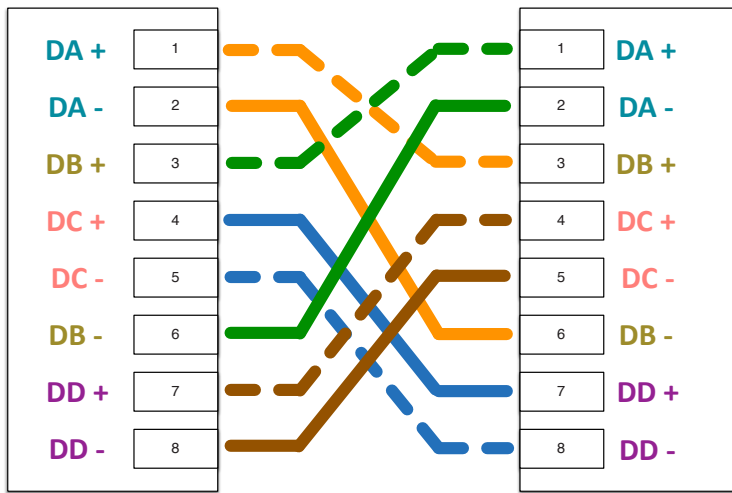

Yost Serial Device Wiring Standard "Rollover"

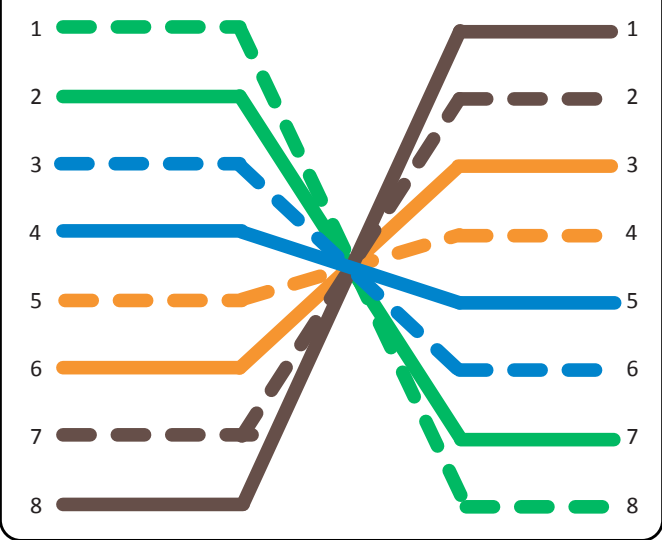

Media Dependent Interface (MDI)
Network Interface Card

Media Dependent Interface (MDI)
Network Interface Card

Optical Fiber



ST - Straight Tip



FC - Field Assembly Connector



SC - Subscriber Connector

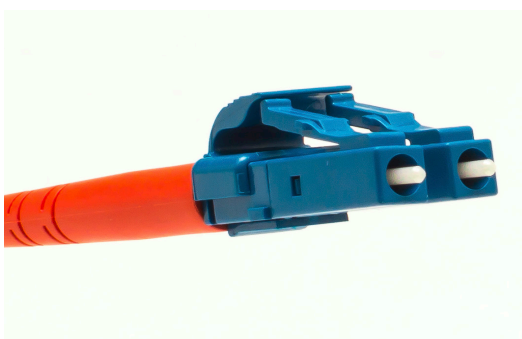

LC - Lucent Connector



MT-RJ - Mechanical Transfer Registered Jack

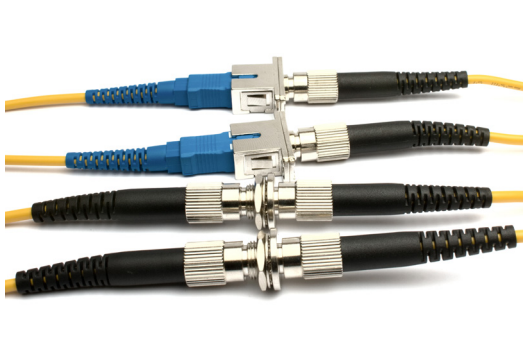

Fiber Couplers

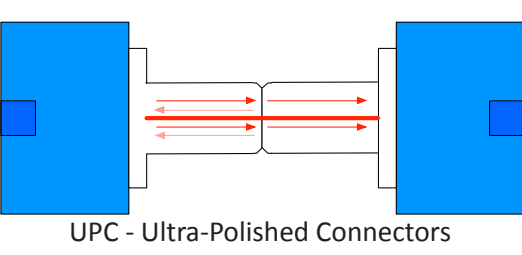

UPC - Ultra-Polished Connectors

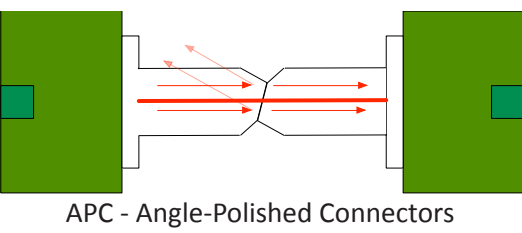

APC - Angle-Polished Connectors

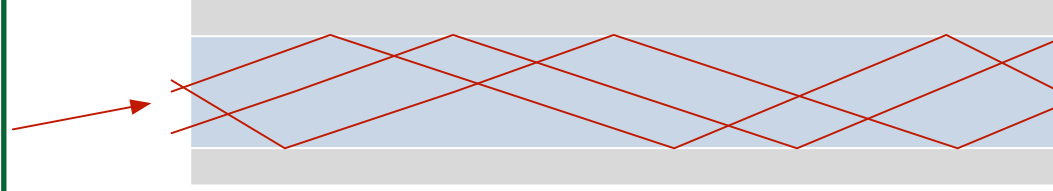

Multi-mode Fiber
Short-range communication, up to 2 km

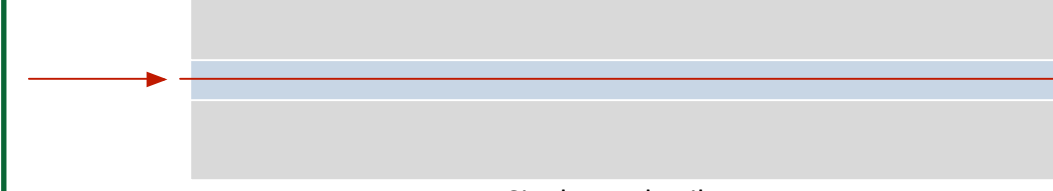

Single-mode Fiber
Long-range communication, up to 100 km

Network Cabling Tools



Cable Crimper

- "Pinch" the connector onto the wire
- The final step of a cable installation



Snips / Electrician's scissors

- Precise cutting
- Wire stripping and cutting notches

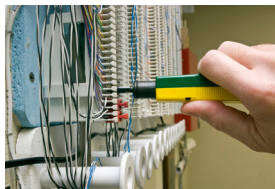

Punch-down Tool

- Forces wire into a wiring block
- Trims the wires and breaks the insulation



Wire stripper

- Easily remove insulation from copper wire



TDR / OTDR

- (Optical) Time Domain Reflectometer
- Estimate fiber lengths, measure signal loss, determine light reflection, create wire maps

Collision Domains and Broadcast Domains

Collision Domains

Separated by switch/bridge interfaces

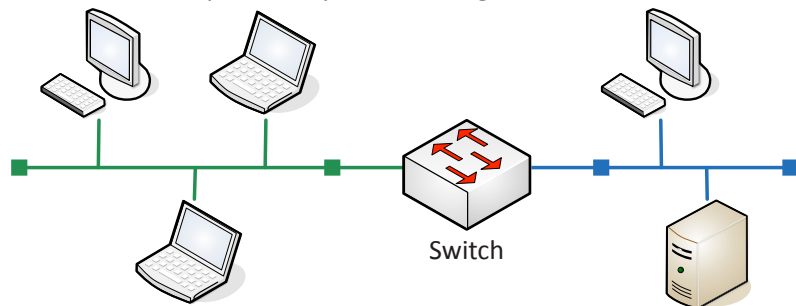

Broadcast Domains

Separated by router interfaces

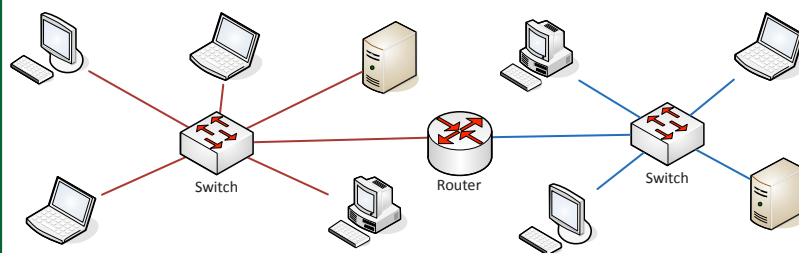

Routing

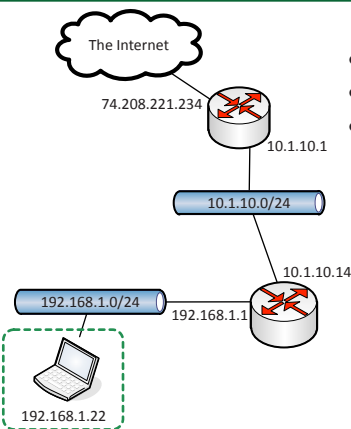

Common Routing Metrics

- Hop count
- Load
- Packet loss
- MTU
- Latency
- Throughput
- Network speed
- Path reliability
- Link utilization

Routing Table

Destination	Gateway	Interface	Metric
0.0.0.0/0	192.168.1.1	192.168.1.22	10
127.0.0.1/8	127.0.0.1	127.0.0.1	1
192.168.1.0/24	192.168.1.22	192.168.1.22	10
192.168.1.22/32	127.0.0.1	127.0.0.1	10
192.168.1.255/32	192.168.1.22	192.168.1.22	10

Link State Routing Protocol

- Routes are based on availability, speed, and other criteria
- Very scalable, used by large networks
- OSPF, IS-IS

Distance-Vector Routing Protocol

- Determine routes based on number of hops
- The deciding vector is the distance
- RIP, RIPv2, BGP

Hybrid Routing Protocol

- A little link state, a little distance-vector
- EIGRP

High availability

- Design a system for smallest chance of downtime
- Higher availability almost always means higher costs

VRRP

- Virtual Router Redundancy Protocol
- The default router isn't real
- Devices use a virtual IP for the default gateway
- If a router disappears, another one takes its place

HSRP

- Hot Standby Router Protocol
- Cisco proprietary version of VRRP
- Default gateway is assigned to a virtual router

Interior Gateway and Exterior Gateway Protocols

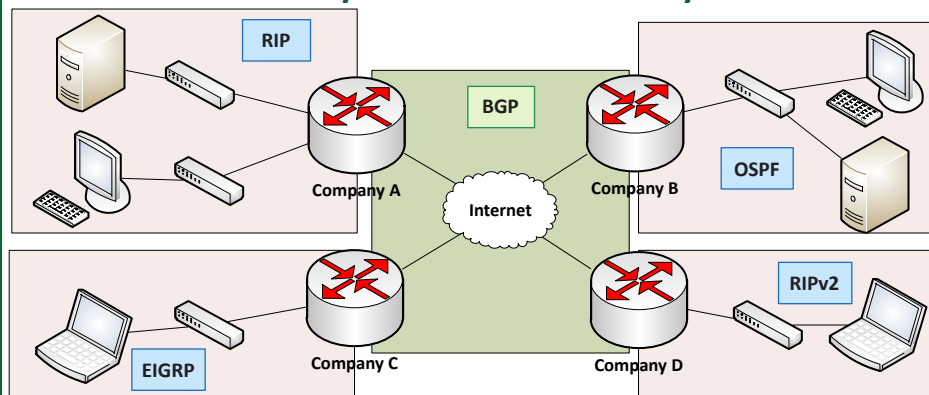

Network Topologies

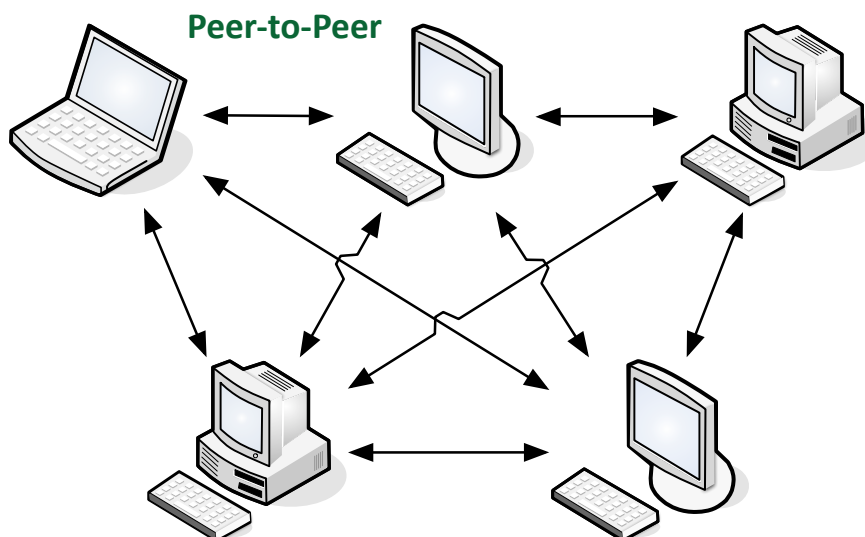
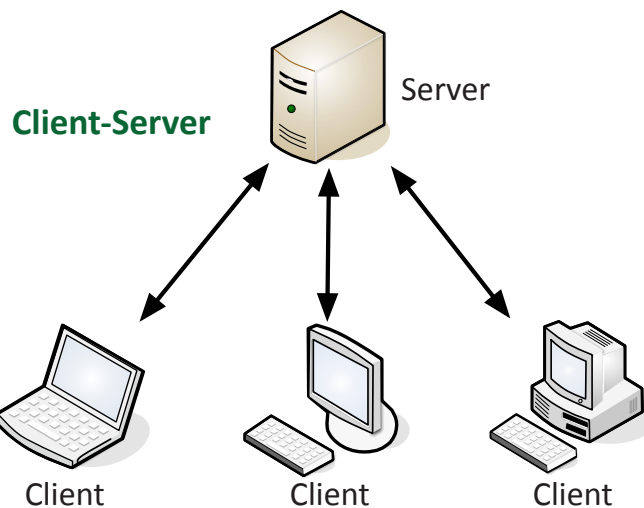
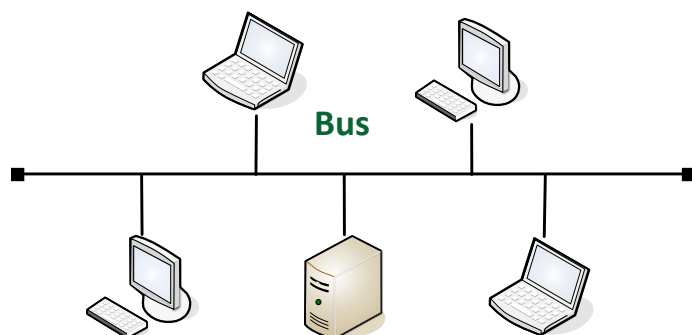
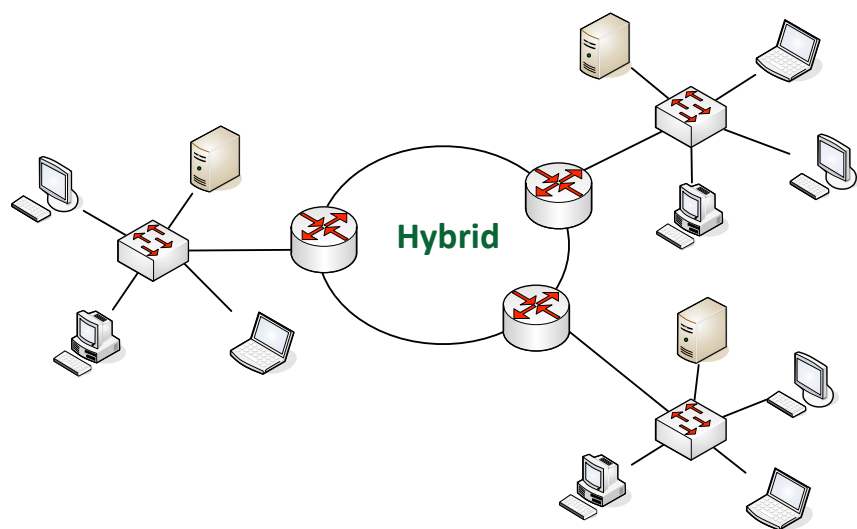
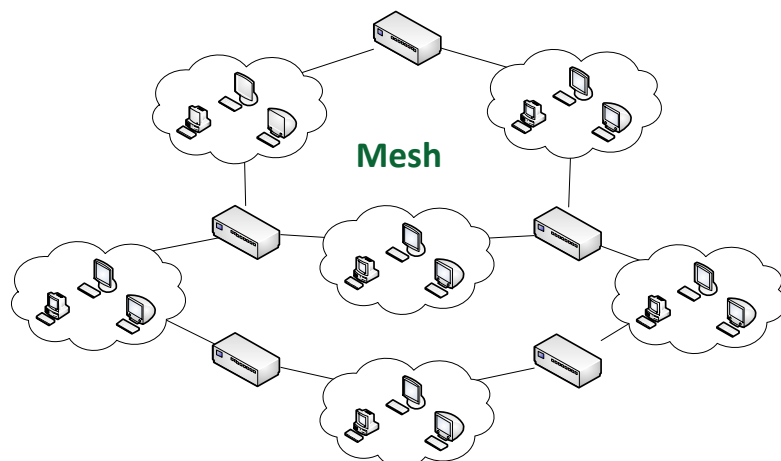
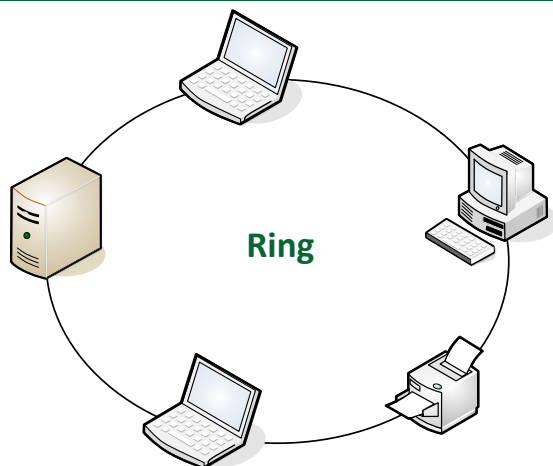
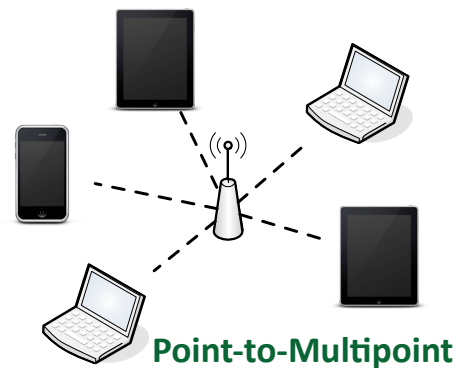
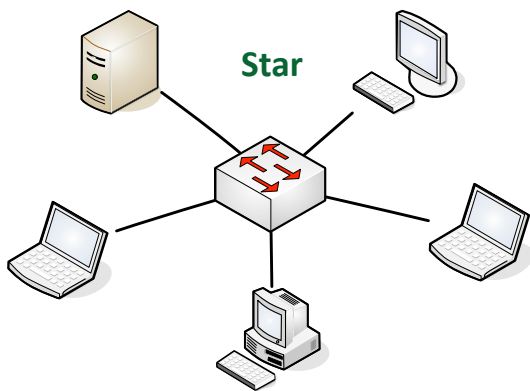

IPv6 Addressing

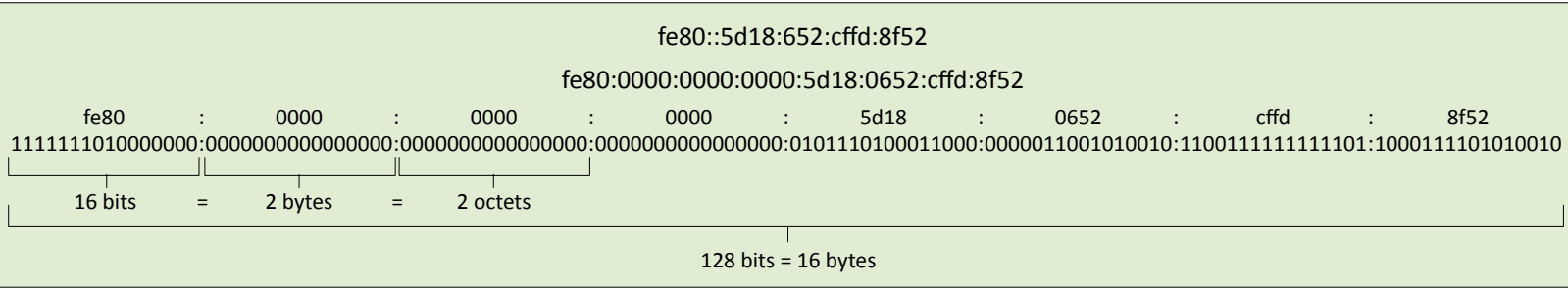

DHCPv6

Very similar process to DHCPv4 - udp/546 (client) and udp/547 (server)

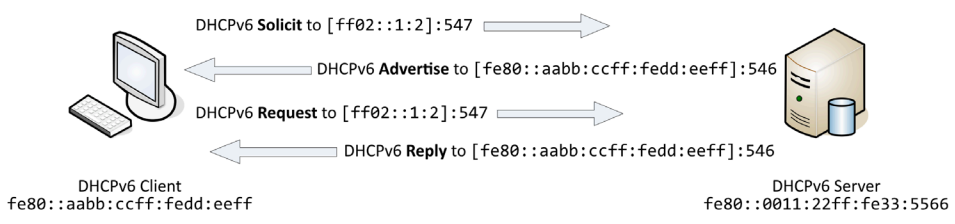

CIDR (Classless Inter-Domain Routing)

CIDR	Mask	Classful	IPv4 Addresses	
/0	0.0.0.0		2 ³² , 4,294,967,296	
/1	128.0.0.0		2 ³¹ , 2,147,483,648	
/2	192.0.0.0		2 ³⁰ , 1,073,741,824	
/3	224.0.0.0		2 ²⁹ , 536,870,912	
/4	240.0.0.0		2 ²⁸ , 268,435,456	
/5	248.0.0.0		2 ²⁷ , 134,217,728	
/6	252.0.0.0		2 ²⁶ , 67,108,864	
/7	254.0.0.0		2 ²⁵ , 33,554,432	
/8	255.0.0.0	A	16,777,216	2 ²⁴ , 16,777,216
/9	255.128.0.0		2 ²³ , 8,388,608	
/10	255.192.0.0		2 ²² , 4,194,304	
/11	255.224.0.0		2 ²¹ , 2,097,152	
/12	255.240.0.0		2 ²⁰ , 1,048,576	
/13	255.248.0.0		2 ¹⁹ , 524,288	
/14	255.252.0.0		2 ¹⁸ , 262,144	
/15	255.254.0.0		2 ¹⁷ , 131,072	
/16	255.255.0.0	B	65,536	2 ¹⁶ , 65,536
/17	255.255.128.0		2 ¹⁵ , 32,768	
/18	255.255.192.0		2 ¹⁴ , 16,384	
/19	255.255.224.0		2 ¹³ , 8,192	
/20	255.255.240.0		2 ¹² , 4,096	
/21	255.255.248.0		2 ¹¹ , 2,048	
/22	255.255.252.0		2 ¹⁰ , 1,024	
/23	255.255.254.0		2 ⁹ , 512	
/24	255.255.255.0	C	256	2 ⁸ , 256
/25	255.255.255.128		2 ⁷ , 128	
/26	255.255.255.192		2 ⁶ , 64	
/27	255.255.255.224		2 ⁵ , 32	
/28	255.255.255.240		2 ⁴ , 16	
/29	255.255.255.248		2 ³ , 8	
/30	255.255.255.252		2 ² , 4	
/31	255.255.255.254		2 ¹ , 2	
/32	255.255.255.255		2 ⁰ , 1	

Subnet Classes

Class	Leading Bits	Network Bits	Remaining Bits	Number of Networks	Hosts per Network	Default Subnet Mask
Class A	0xxx (1-126)	8	24	128	16,777,214	255.0.0.0
Class B	10xx (128-191)	16	16	16,384	65,534	255.255.0.0
Class C	110x (192-223)	24	8	2,097,152	254	255.255.255.0
Class D (multicast)	1110 (224-239)	Not defined	Not defined	Not defined	Not defined	Not defined
Class E (reserved)	1111 (240-254)	Not defined	Not defined	Not defined	Not defined	Not defined

RFC 1918 Private Addresses

IP address range	Number of addresses	Classful description	Largest CIDR block (subnet mask)	Host ID size
10.0.0.0 – 10.255.255.255	16,777,216	single class A	10.0.0.0/8 (255.0.0.0)	24 bits
172.16.0.0 – 172.31.255.255	1,048,576	16 contiguous class Bs	172.16.0.0/12 (255.240.0.0)	20 bits
192.168.0.0 – 192.168.255.255	65,536	256 contiguous class Cs	192.168.0.0/16 (255.255.0.0)	16 bits

APIPA (Automatic Private IP Addressing)

- 169.254.0.1 through 169.254.255.254
- First and last 256 addresses are reserved, making the functional block 169.254.1.0 through 169.254.254.255

Network Communication

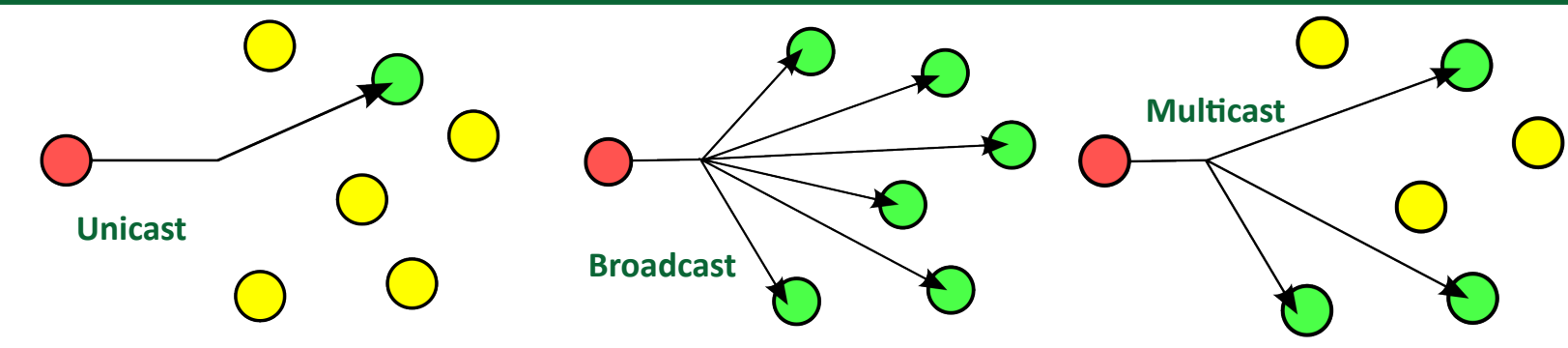

Software Defined Networking

- Networking devices have two functional planes of operation
 - Control plane, data plane
- Directly programmable - Configuration is different than forwarding
- Agile - Changes can be made dynamically
- Centrally managed - Global view, single pane of glass
- Programmatically configured - No human intervention
- Open standards / vendor neutral - A standard interface to the network

Virtual Networks and Firewalls

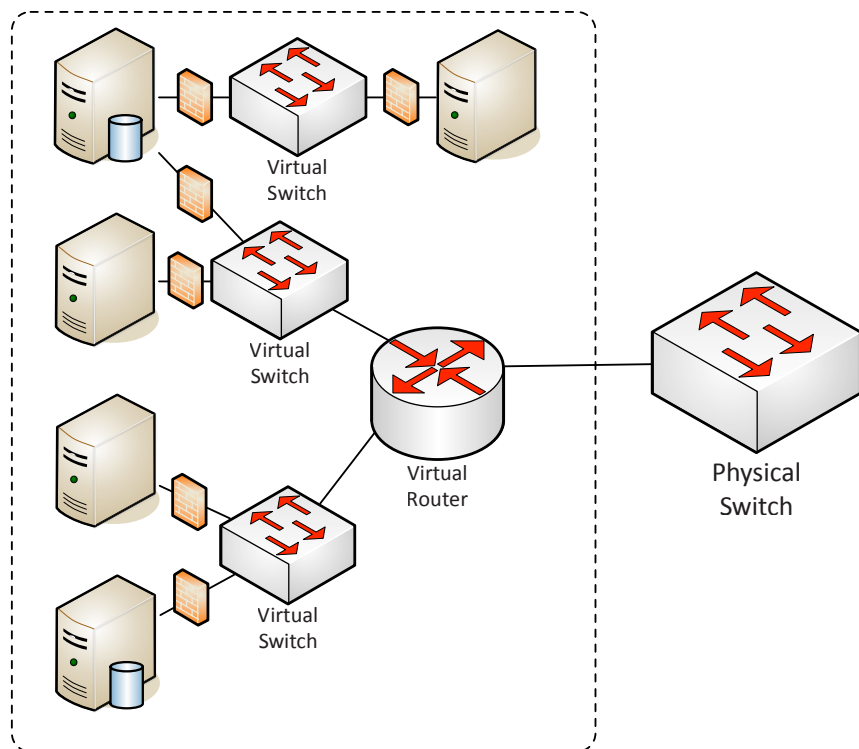

802.1Q Trunking

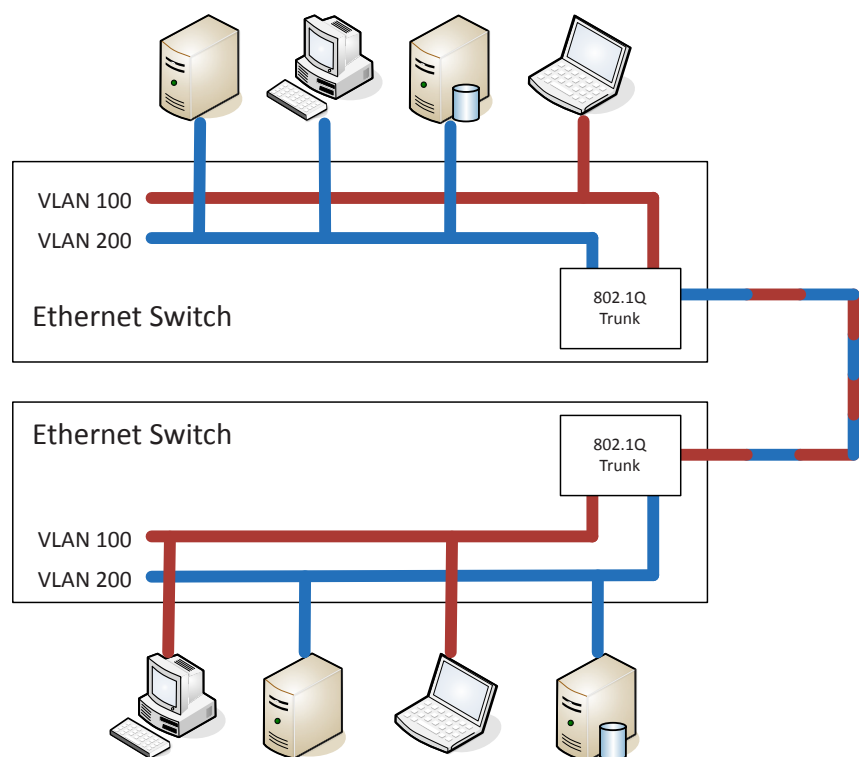

Quality of Service (QoS)

QoS

- Prioritize traffic performance
- Many different methods

CoS (Class of Service)

- Ethernet frame header in an 802.1q trunk
- Usually applied in the intranet (not from an ISP)

Differentiated Services (DiffServ)

- QoS bits are enabled in the IPv4 header
- Bits are set external to the application
- Routers and switches have to play along

DSCP (Differentiated Services Code Point)

- DS (Differentiated Services) field in the IP header

Storage Area Networks

Network Attached Storage (NAS)

- Connect to a shared storage device across the network
- File-level access

Storage Area Network (SAN)

- Looks and feels like a local storage device
- Block-level access
- Very efficient reading and writing

Jumbo Frames

- Ethernet frames with more than 1,500 bytes of payload
- Increases transfer efficiency
- Ethernet devices must support jumbo frames

iSCSI

- Internet Small Computer Systems Interface
- Send SCSI commands over an IP network

Fibre Channel (FC)

- A specialized high-speed topology
- Connect servers to storage
- 2-, 4-, 8- and 16-gigabit per second rates
- Supported over both fiber and copper

Fibre Channel over Ethernet (FCoE)

- Use Fibre Channel over an Ethernet network
- Non-routable

Fibre Channel over IP (FCIP)

- Encapsulate Fibre Channel data into IP packets
- Geographically separate the servers from the storage

Cloud Technologies

Platform as a Service (PaaS)

- No servers, no software, no maintenance team, no HVAC
- Someone else handles the platform, you handle the product
- Salesforce.com

Software as a Service (SaaS)

- On-demand software
- No local installation
- Google Mail

Infrastructure as a service (IaaS)

- Sometimes called Hardware as a Service (HaaS)
- Outsource your equipment
- Web server and email server providers

Non-Overlapping Channels for 2.4 GHz WLAN

802.11b (DSSS), 22 MHz channel width

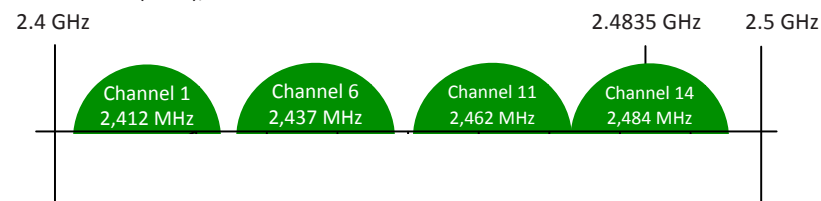

802.11g/n (OFDM), 20 MHz channel width - 16.25 MHz used by sub-carriers

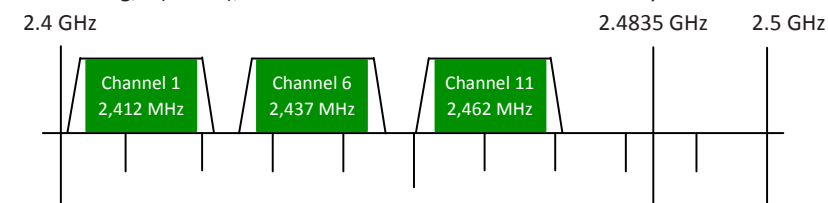

802.11n (OFDM), 40 MHz channel width - 33.75 MHz used by sub-carriers

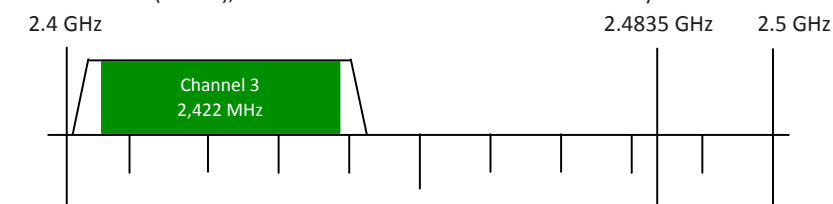

Denial of Service

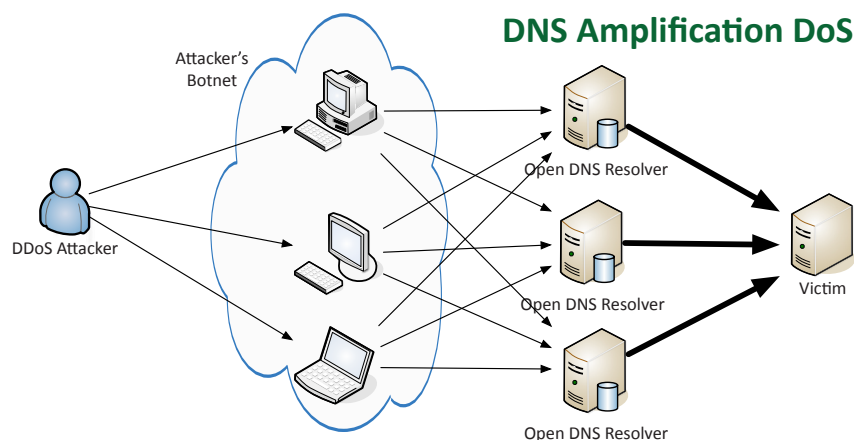

Wireless Security

WEP

- 64-bit or 128-bit key size
- Cryptographic vulnerabilities found in 2001
- WEP can no longer be used

WPA

- Short-term workaround after WEP
- Used RC4 cipher as a TKIP (Temporal Key Integrity Protocol)
- TKIP has its own vulnerabilities

WPA2

- Replaced TKIP with CCMP (Counter Mode with Cipher Block Chaining Message Authentication Code Protocol)
- Replaced RC4 with AES (Advanced Encryption Standard)
- WPA2 is the latest and most secure wireless encryption method

WPA2-Enterprise

- WPA2-Enterprise adds 802.1x
- RADIUS server authentication

Power over Ethernet

POE: IEEE 802.3af

- The original PoE specification
- Included in 802.3at, now part of 802.3-2012
- 15.4 watts DC power, maximum current of 350 mA

POE+: IEEE 802.3at-2009

- The updated PoE specification
- Now also part of 802.3-2012
- 25.5 watts DC power, maximum current of 600 mA

Insecure and Secure Protocols

Communication protocols

- Insecure: SLIP (Serial Line Interface Protocol)
- Secure: IPsec - Internet Protocol Security

Terminal communication

- Insecure: TELNET
- Secure: SSH - Secure Shell

Browsers

- Insecure: HTTP - Hypertext Transport Protocol
- Secure: TLS/SSL - Transport Layer Security / Secure Sockets Layer

File transfers

- Insecure: FTP, TFTP
- Secure: SFTP - Secure (SSH) File Transfer Protocol

Network management

- Insecure: SNMPv1 and SNMPv2
- Secure: SNMPv3

Switch Port Security

DHCP Snooping

- IP tracking on a layer 2 device (switch)
- Switch watches for DHCP conversations
- Filters invalid IP and DHCP information

Dynamic ARP inspection (DAI)

- Stops ARP poisoning at the switch level
- Relies on DHCP snooping for intel
- Intercept all ARP requests and responses
- Invalid IP-to-MAC address bindings are dropped

MAC limiting and filtering

- Media Access Control - the physical Ethernet address
- Collect the MAC address of all devices
- MAC addresses are easily spoofed

VLAN assignments

- Network segmentation
- The type of separation depends on the application
- Separate by VLAN

Cryptographic Hash Functions

MD5 (Message Digest Algorithm)

- 128-bit hash value
- 1996: Vulnerabilities found - not collision resistant

SHA (Secure Hash Algorithm)

- A US Federal Information Processing Standard
- SHA-1
 - Widely used, 160-bit digest, 2005: Collision attacks published
- SHA-2
 - The preferred SHA variant, Up to 512-bit digests
 - SHA-1 is now retired for most US Government use

User Authentication

PAP (Password Authentication Protocol)

- Unsophisticated, insecure, clear text password exchange

CHAP / MS-CHAP

- Challenge-Handshake Authentication Protocol
- Encrypted challenge sent over the network

EAP

- Extensible Authentication Protocol
- Many different ways to authenticate based on RFC standards
- WPA and WPA2 use five EAP types as authentication mechanisms

PEAP

- Protected Extensible Authentication Protocol
- Created by Cisco, Microsoft, and RSA Security
- Encapsulates EAP in a TLS tunnel, one certificate on the server

Kerberos

- Authenticate once, trusted by the system
- No need to re-authenticate to everything
- Standard since the 1980s
- Microsoft starting using Kerberos in Windows 2000

Firewall Connectivity

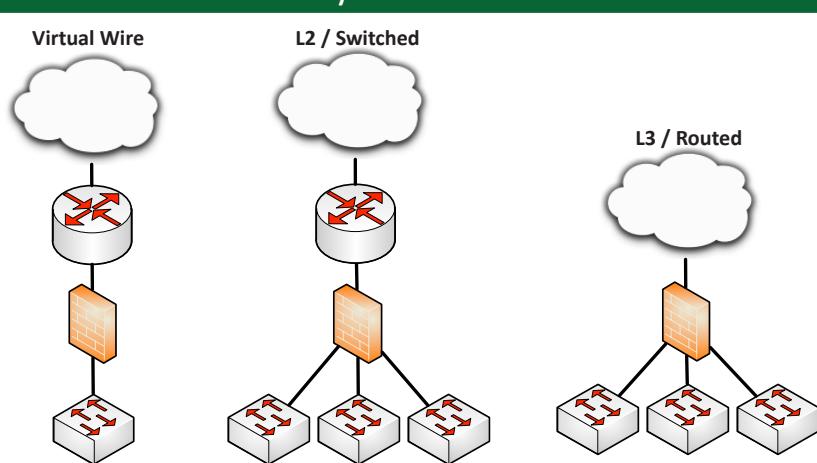

Command Line Tools

ipconfig and ifconfig - View and manage IP configuration

- `ipconfig` - Windows TCP/IP config
- `ipconfig /all` - Display all IP configuration details
- `ipconfig /release` - Release the DHCP lease
- `ipconfig /renew` - Renew the DHCP lease
- `ipconfig /flushdns` - Flush the DNS resolver cache
- `ifconfig` - Linux interface configuration

netstat - Display network statistics

- `netstat -a` - Show all active connections
- `netstat -b` - Show binaries
- `netstat -n` - Do not resolve names

ping - Test reachability

- `ping <ip address>` - Test reachability to a TCP/IP address
- `ping -t <ip address>` - Ping until stopped with Ctrl-c
- `ping -a <ip address>` - Resolve address to a hostname
- `ping -n <count> <ip address>` - Send # of echo requests
- `ping -f <ip address>` - Send with Don't Fragment flag set

tracert - Determine the route a packet takes to a destination

- Takes advantage of ICMP Time to Live Exceeded error message
- Not all devices will reply with ICMP Time Exceeded messages
- `tracert <ip address>`

nbstat - Query NetBIOS over TCP/IP information

- `nbstat -n` - List local NetBIOS names
- `nbstat -A <ip address>` - List remote NetBIOS names
- `nbstat -a <device name>` - List remote NetBIOS names

nslookup and dig - Lookup information from DNS servers

- `nslookup <ip address>`
- `dig <ip address>`

arp - Address resolution protocol information

- `arp -a` - View the local ARP table

pathping - Combination of ping and tracert

- `pathping <ip address>`

The Network Troubleshooting Process

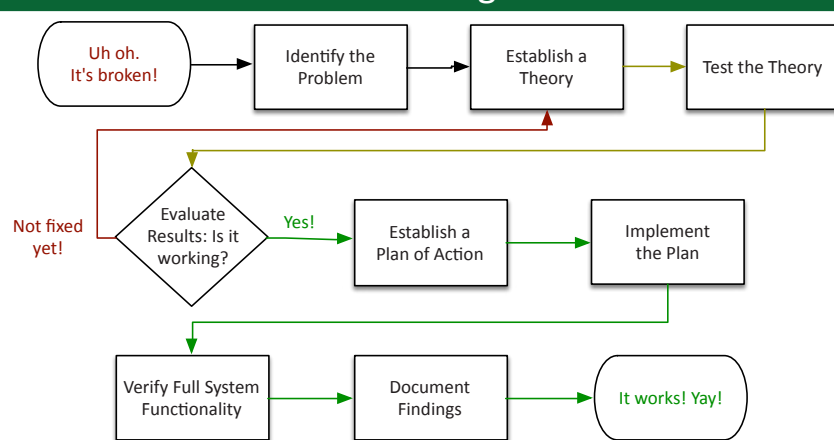

- Identify the problem
 - Information gathering, identify symptoms, question users
- Establish a theory of probable cause
- Test the theory to determine cause
- Establish a plan of action to resolve the problem and identify potential effects
- Implement the solution or escalate as necessary
- Verify full system functionality and, if applicable, implement preventative measures
- Document findings, actions and outcomes

Physical Testing Tools



Cable Tester

- Can identify missing pins or crossed wires
- Not generally used for frequency testing



Multimeter

- AC/DC voltages
- Continuity, wire mapping



Toner Probe

- Puts an analog sound on the wire
- Inductive probe doesn't need to touch the copper

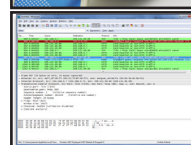

Protocol analyzer

- Capture and display network traffic
- Use a physical tap or redirect on the switch

Troubleshooting Network Cabling

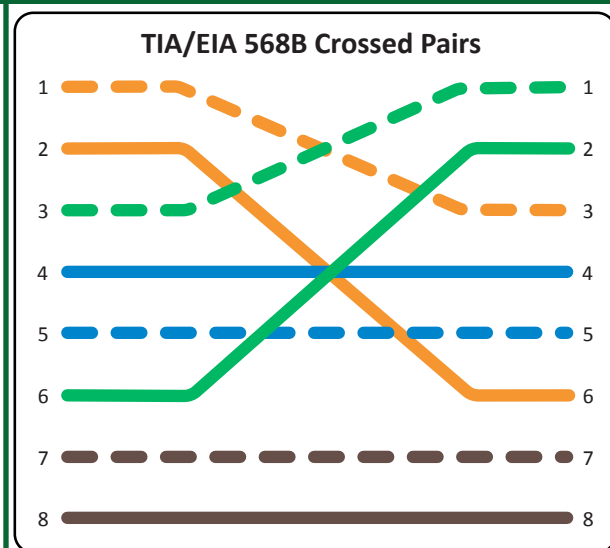
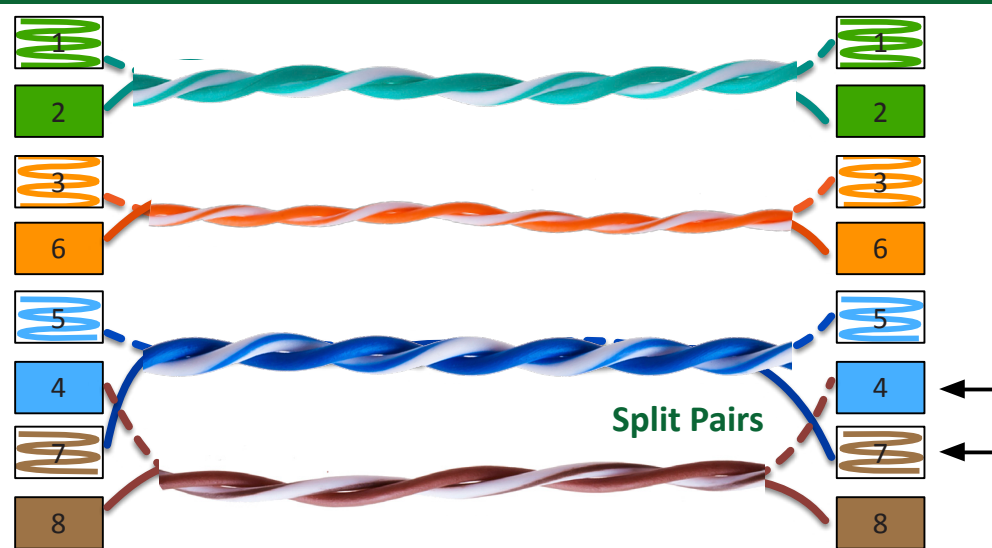

The OSI Model

Layer 7 - Application	The layer we see - Google Mail, Twitter, Facebook
Layer 6 - Presentation	Encoding and encryption (SSL/TLS)
Layer 5 - Session	Communication between devices (Control protocols, tunneling protocols)
Layer 4 - Transport	The "post office" layer (TCP segment, UDP datagram)
Layer 3 - Network	The routing layer (IP address, router, packet)
Layer 2 - Data Link	The switching layer (Frame, MAC address, EUI-48, EUI-64, Switch)
Layer 1 - Physical	Signaling, cabling, connectors (Cable, NIC, Hub)

The TCP/IP Model

Application	FTP, BOOTP, TFTP, DNS, HTTP(S), TLS/SSL, VoIP, SSH, POP3, IMAP4, NTP, Telnet, SMTP, SNMP
Transport	TCP, UDP
Internet	IPv4, IPv6, ICMP, IGMP
Link	ARP

OSI Mnemonics

- Please Do Not Trust Sales Person's Answers
- All People Seem To Need Data Processing
- Please Do Not Throw Sausage Pizza Away!

Octal Conversion

4,096	512	64	8	1
8^4	8^3	8^2	8^1	8^0

Encapsulation and Decapsulation

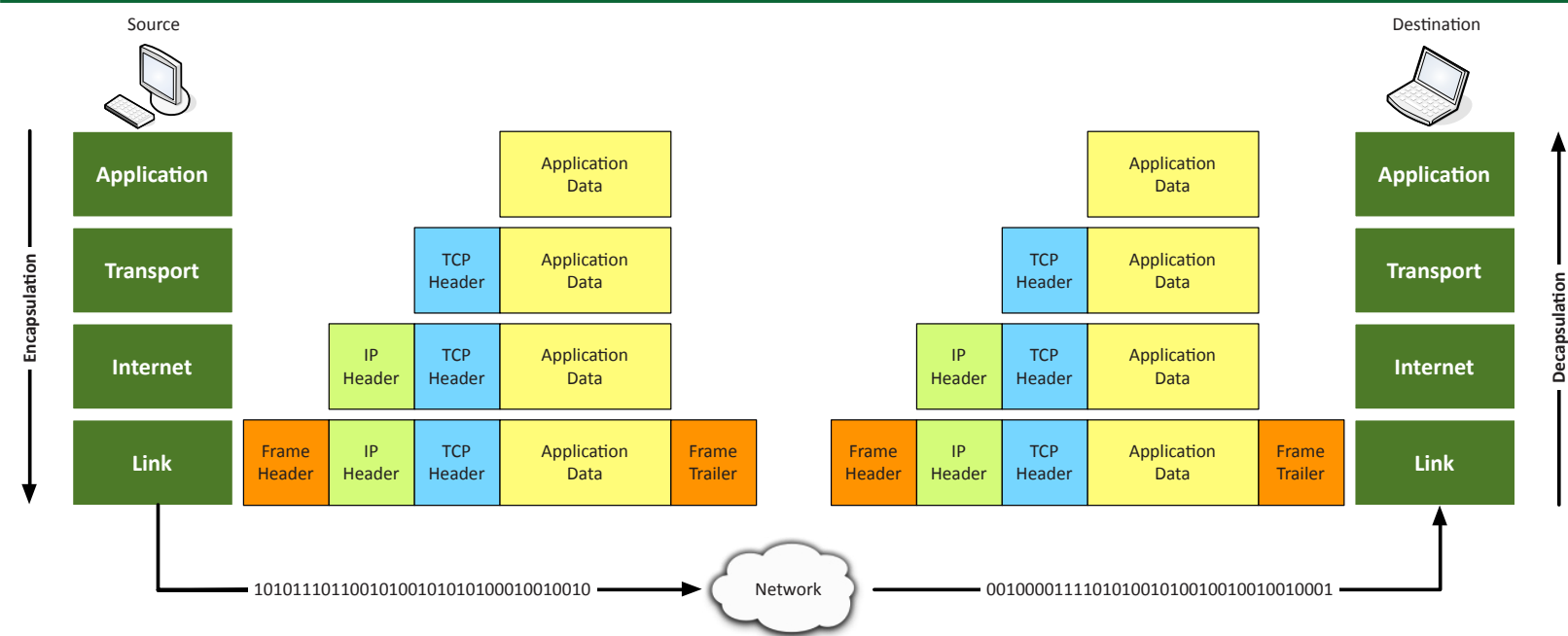

Binary Conversion

2^{12}	2^{11}	2^{10}	2^9	2^8	2^7	2^6	2^5	2^4	2^3	2^2	2^1	2^0
4,096	2,048	1,024	512	256	128	64	32	16	8	4	2	1

Time-division Multiplexing (TDM)

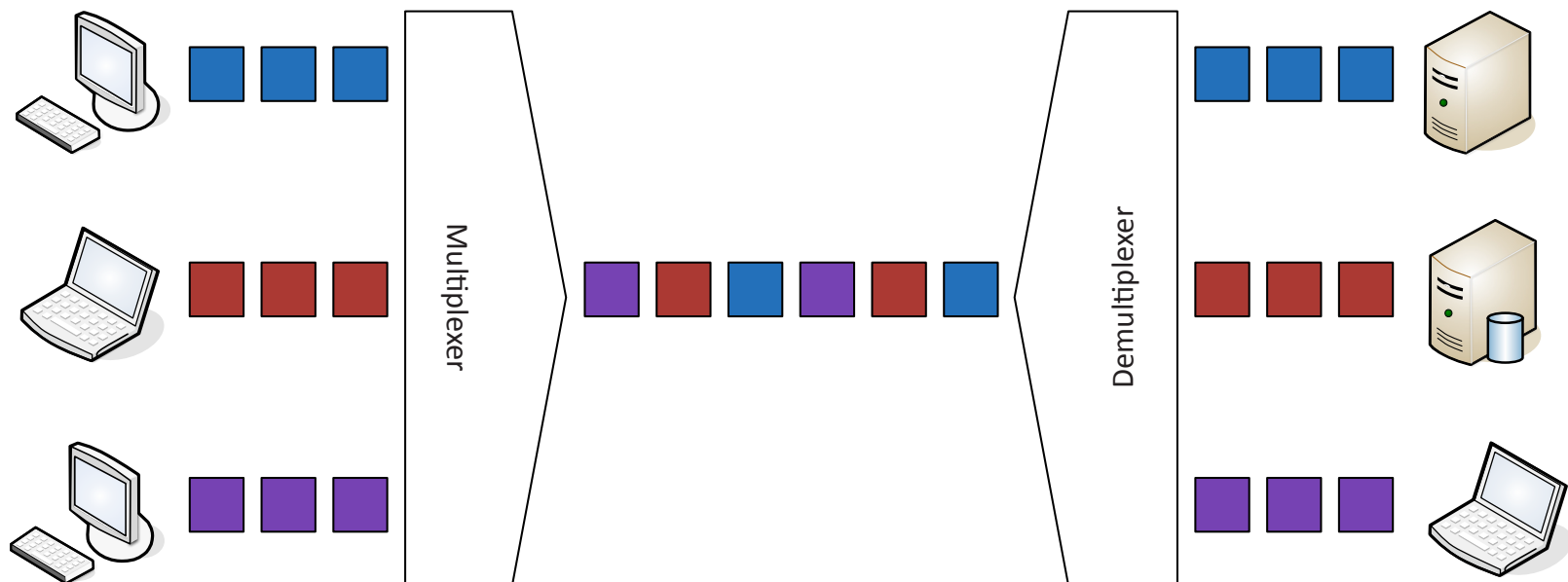

Hexadecimal Conversion

0	1	2	3	4	5	6	7	8	9	10	11	12	13	14	15	4,096	256	16	1
0	1	2	3	4	5	6	7	8	9	A	B	C	D	E	F	16^3	16^2	16^1	16^0

Wireless Standards

	Frequencies	Maximum allowable streams	Maximum theoretical throughput (per stream)	Maximum theoretical throughput (total)
802.11a	5 GHz	1	54 Mbit/s	54 Mbit/s
802.11b	2.4 GHz	1	11 Mbit/s	11 Mbit/s
802.11g	2.4 GHz	1	54 Mbit/s	54 Mbit/s
802.11n	5 GHz / 2.4 GHz	4	150 Mbit/s	600 Mbit/s
802.11ac	5 GHz	8	866.7 Mbit/s	6,934 Mbit/s

Ethernet Standards

10 Mbit/s Ethernet

- 10BASE-2 - Coax / "Thinnet" over RG-58A/U, 185 meters
- 10BASE-T - Twisted pair copper, 100 meters

100 Mbit/s Ethernet

- 100BASE-TX - Category 5 twisted pair, 100 meters
- 100BASE-FX - Multimode fiber (2 km), Single-mode fiber (over 2 km)

1000 Mbit/s (1 Gbit/s) Ethernet

- 1000BASE-T - Category 5/5e, uses all pairs, 100 meters
- 1000BASE-TX - Category 5/5e, uses two pair, 100 meters - rarely seen
- 1000BASE-LX - Long wavelength fiber, over 5 kilometers
- 1000BASE-SX - Short wavelength fiber, 550 meter distance

10 Gbit/s Ethernet

- 10GBASE-T - Cat 6 (55 meters), Cat 6a (100 meters)
- 10GBASE-SR (Short Range) - Multimode fiber, 300 meters
- 10GBASE-ER (Extended Range) - Single-mode fiber, 40 km
- 10GBASE-SW - 10 gigabit Ethernet over SONET and SDH

IEEE 1905.1 - Networking ubiquity for the home

- 802.11 wireless, power-line networks, Ethernet, and MoCA
- Power-line communication (PLC) - IEEE 1901 - 500 Mbit/s

Ethernet over HDMI

- HEC - HDMI Ethernet Channel, 100 Mbit/s Ethernet
- Part of the HDMI specification

CSMA/CD and CSMA/CA

CSMA/CD

- CS - Carrier Sense - Is anyone communicating across the media
- MA - Multiple Access - More than one device on the network
- CD - Collision Detect - Determine if two stations talk at once
- Commonly seen on half-duplex Ethernet

CSMA/CA

- CA - Collision Avoidance - Common on wireless networks
- Common to see Ready To Send (RTS) / Clear To Send (CTS)

IDF and MDF

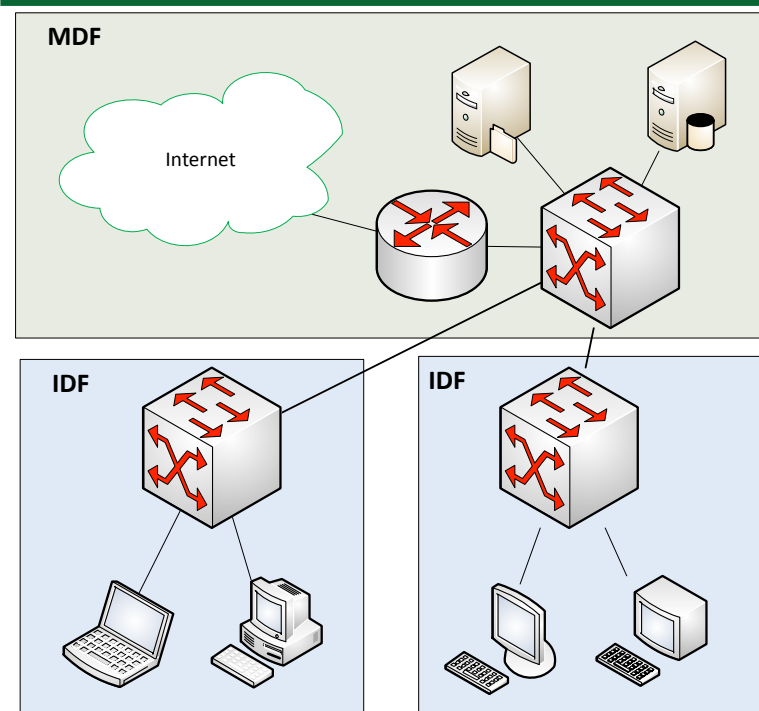

Ports and Protocols

Protocol	Port	Name	Description
Common Network Protocols			
ARP	-	Address Resolution Protocol	Resolve IP address to MAC
TCP	-	Transmission Control Protocol	Connection-oriented network communication
UDP	-	User Datagram Protocol	Connectionless network communication
Common Network Management Protocols			
DHCP	udp/67, udp/68	Dynamic Host Configuration Protocol	Update to BOOTP
DNS	udp/53, tcp/53	Domain Name System	Convert domain names to IP addresses
ICMP	-	Internet Control Message Protocol	Send management messages between devices
SNMP	udp/161	Simple Network Management Protocol	Gather statistics and manage network devices
Telnet	tcp/23	Telecommunication Network	Remote console login to network devices
SSH	tcp/22	Secure Shell	Encrypted console login
RDP	tcp/3389	Remote Desktop Protocol	Graphical display of remote device
Common Application Protocols			
FTP	tcp/20, tcp/21	File Transfer Protocol	Sends and receives files between systems
TFTP	udp/69	Trivial File Transfer Protocol	A very simple file transfer application
SMB	tcp/445	Server Message Block	Windows file transfers and printer sharing
SMTP	tcp/25	Simple Mail Transfer Protocol	Transfer email between mail servers
POP3	tcp/110	Post Office Protocol version 3	Receive mail into a mail client
IMAP4	tcp/143	Internet Message Access Protocol v4	A newer mail client protocol
HTTP	tcp/80	Hypertext Transfer Protocol	Web server communication
HTTPS	tcp/443	Hypertext Transfer Protocol Secure	Web server communication with encryption
TLS/SSL	tcp/443	Transport Layer Security and Secure Sockets Layer	Secure protocols for web browsing
NetBIOS	udp/137	NetBIOS name service	Register, remove, and find services by name
NetBIOS	udp/138	NetBIOS datagram service	Connectionless data transfer
NetBIOS	tcp/139	NetBIOS session service	Connection-oriented data transfer
Voice over IP Protocols			
SIP	tcp/5060-5061	Session Initiation Protocol	Voice over IP signaling protocol
RTP	dynamic	Real-time Transport Protocol	Voice over IP media stream
MGCP	udp/2427	Media Gateway Control Protocol - Gateway	Call Agent to Gateway
MGCP	udp/2727	Media Gateway Control Protocol - Call Agent	Gateway to Call Agent
H.323	tcp/1720	ITU Telecommunication H.32x protocol series	Voice over IP signaling

Study Tips

Exam Preparation

- Download the exam objectives, and use them as a master checklist
- Use as many training materials as possible. Books, videos, and Q&A guides can all provide a different perspective of the same information.
- It's useful to have some hands-on, especially with network troubleshooting commands.

Taking the Exam

- Use your time wisely. You've got 90 minutes to get through everything.
 - Choose your exam location carefully. Some sites are better than others.
 - Get there early. Don't stress the journey.
 - Manage your time wisely. You've got 90 minutes to get through everything.
 - Wrong answers aren't counted against you. Don't leave any blanks!
 - Mark difficult questions and come back later.
- You can answer the questions in any order.